

## Process

CUE (0.6 $\mu$ m)

## Key Features

- Full 8-Bit Resolution and Linearity
- Small Area 0.044 mm<sup>2</sup>;
- Size x = 216 $\mu$ m, y = 202 $\mu$ m
- Supply Voltage 5V  $\pm$  10%
- Only Single Power Supply Required

## Symbol

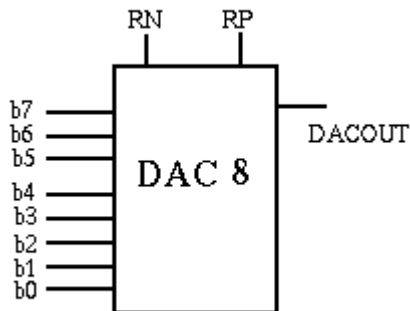

## General Description

This Macro Cell is an 8-Bit digital to analog converter.

## Functional Description

The architecture is based on two resistor dividers. Because of its high output impedance, which is also code dependent, it must be used together with a low offset operational amplifier at the output (e.g. OP03B). VRN and VRP must be within the common mode range of the opamp (e.g. between 1.5V and 3.5V).

## Pinlist

Pin	Description	Cap.
RP	Positive Reference Voltage	
RN	Negative Reference Voltage	
DACOUT	Analog Output	
b<7:0	Data Input b(0) = LSB	

## POWER SUPPLIES

The converter requires one power supply (vdda, gnd).

## TECHNICAL DATA FOR 5V SUPPLY

( $T_{\text{junction}} = 0$  to  $+85^{\circ}\text{C}$ ,  $V_{\text{DDA}} = 5\text{V} \pm 10\%$ , unless otherwise specified)

## GENERAL PARAMETERS

Symbol	Parameter	Conditions	Min	Typ	Max	Unit
	Resolution		8			Bit
Vin	Input Voltage Range		VSS		VDD	V
DNL	Differential Nonlinearity	VRP = 3.5V VRN = 1.5V VDD = 5V temp = 25°C		± 0.25		LSB
INL	Integral Nonlinearity	VRP = 3.5V VRN = 1.5V VDD = 5V temp = 25°C		± 0.25		LSB
Vos	Input Offset Voltage	VRP = 3.5V VRN = 1.5V VDD = 5V temp = 25°C		± 0.25		LSB
Rref	Reference Impedance		5.9	8	10.7	kOhms
Vdd	Power Supply Range		4.5	5.0	5.5	V
Idd	Power Supply Current			0.13 <sup>1)</sup>		mA
PVdd	Power Consumption			0.13 <sup>1)</sup>		mW
Rout	Output Resistance			21 <sup>2)</sup>		kOhms

<sup>1)</sup> Vrefp – Vrefn = 1V

<sup>2)</sup> Middle of the resistor string; Code: 0111 0111

(output resistance is code-dependent)

Idd includes the current through the resistor string

## TRANSIENT PARAMETERS

Symbol	Parameter	Conditions	Min	Typ	Max	Unit
Ts	Settling Time	5V, 25°C Cload = 30pF	<1			µs

$$V_{\text{out}} = (V_{\text{RP}} - V_{\text{RN}}) / 256 * \text{code}_{\text{in}} + V_{\text{RN}}$$

## Contact

austriamicrosystems AG  
A 8141 Schloss Premstätten, Austria  
T. +43 (0) 3136 500 5333  
F. +43 (0) 3136 525 5755  
support@austriamicrosystems.com  
www.austriamicrosystems.com

## Copyright

Copyright © 2002 austriamicrosystems. Trademarks registered ®. All rights reserved. The material herein may not be reproduced, adapted, merged, translated, stored, or used without the prior written consent of the copyright owner. To the best of its knowledge, austriamicrosystems asserts that the information contained in this publication is accurate and correct.