

# 2 GHz Band Power Dividers/Combiners

## C/D Series

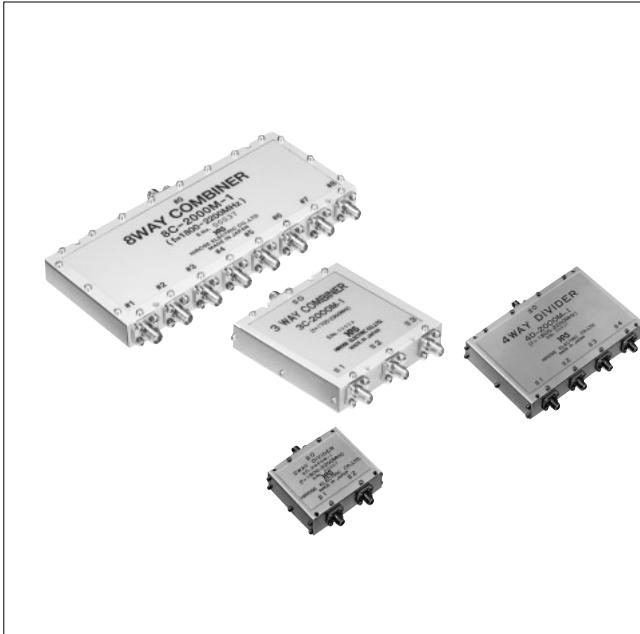

### ■ Features

#### 1. Division System

The micro stripline method, which uses the principle of the  $\lambda/4$  impedance converter, provides excellent high frequency performance.

#### 2. High Performance

The low insertion loss and high isolation (of over 20 dB) afforded by the Wilkinson circuit structure make these power dividers ideal for use in portable telephone base stations, measuring instruments, and for measurements.

#### 3. Highly Reliable Design

Connectors are of the SMA type and use stainless steel for extremely high performance.

The case uses corrosion-resistant aluminum and is both miniature and lightweight.

### ■ Product Specifications

Ratings	Frequency range Characteristic impedance Maximum Input Power	1.7 to 2.3 GHz 50 ohms 1 to 25 W	Operating temperature range Operating relative humidity	-10°C to +65°C 95% Max.
---------	--	--	--	----------------------------

● Please see the specification items for details concerning insertion loss, VSWR, and isolation.

Item	Standard	Conditions
1. Vibration	No damage, cracks, or parts dislocation	Frequency: 10 to 55 Hz, single amplitude of 0.75 mm, 2 hours in each of the 3 axis
2. Shock		Acceleration of 294 m/s <sup>2</sup> , sine half-wave waveform, 3 cycles in each of the 3 axis
3. Temperature cycle		Temperature: -40°C → +15°C to +35°C → +85°C → +15°C to +35°C Time: 30 → 2 to 3 max. → 30 → 2 to 3 max. (Minutes) 100 cycles

● The test method conforms to MIL-STD-202.

### ■ Materials

Part	Material	Finish
Connector Body	Stainless steel	Passivated
Connector female contacts	Beryllium copper	Gold plating
Connector Insulator	PTFE	-----
Cover	Aluminum	Conductive white alumite
Case	Aluminum	Conductive white alumite
Board	Dielectric	Solder coating

### ■ Ordering Information

**2 D - 2000M - 2**  
 ① ② ③ ④

① Number of Divisions (Number of Combination)
② Series Name: D: Divider C: Combiner
③ Center Frequency 2000M : 2000MHz
④ Suffix

# 2WAY POWER DIVIDER

## ■SPECIFICATION

Part Number	Frequency Range (GHz)	Insertion Loss (dB Max)	V.S.W.R. (Max)	Isolation (dB Min)	Power (W)	Weight (g)
2D-2000M-1	1.8~2.2	※(1) 0.4	※(2) 1.3	※(3) 20	20	110

※(1)The value of the insertion loss is the insertion loss minus the calculation value of 3 dB.

※(2)The V.S.W.R. is applicable to port #0, #1, and #2. (See the Dimensions Diagram for the port numbers.)

※(3)Applicable between the divider contacts.

## ■External Dimensions

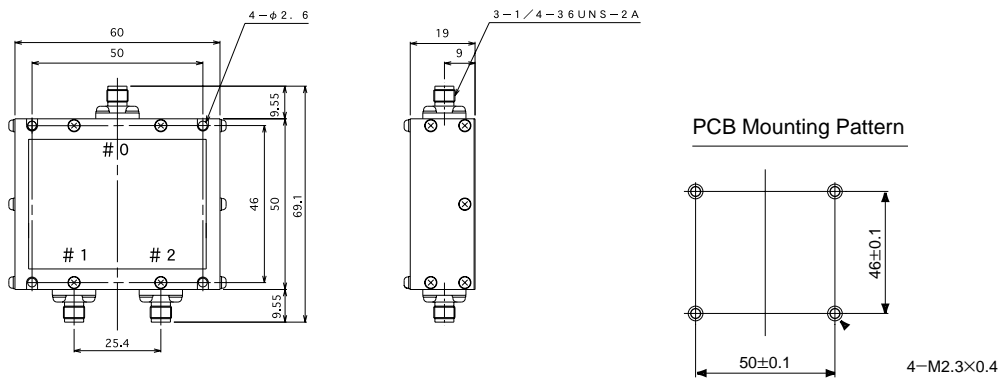

# 4WAY POWER DIVIDER

## ■SPECIFICATION

Part Number	Frequency Range (GHz)	Insertion Loss (dB Max)	V.S.W.R. (Max)	Isolation (dB Min)	Power (W)	Weight (g)
4D-2000M-1	1.8~2.2	※(1) 0.6	※(2) 1.3	※(3) 20	20	260

※(1)The value of the insertion loss is the insertion loss minus the calculation value of 6 dB.

※(2)The V.S.W.R. is applicable to port #0, #1, #2, #3, and #4. (See the Dimensions Diagram for the port numbers.)

※(3)Applicable between the divider contacts.

## ■External Dimensions

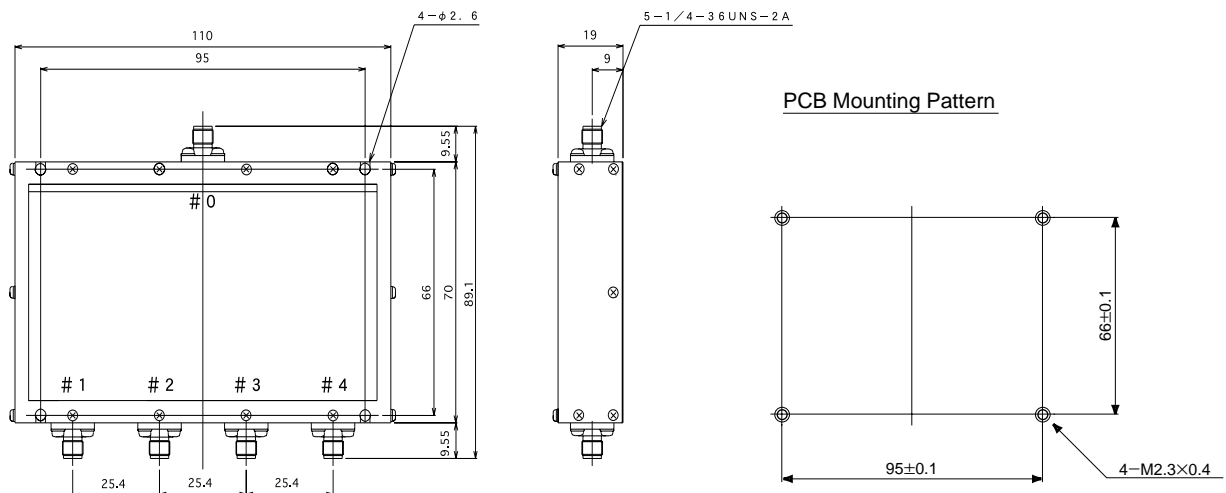

# 8WAY POWER DIVIDER

## SPECIFICATION

Part Number	Frequency Range (GHz)	Insertion Loss (dB Max)	V.S.W.R. (Max)	Isolation (dB Min)	Power (W)	Weight (g)
8D-2000M-1	1.8~2.2	※(1) 1	※(2) 1.3	※(3) 20	20	480

※(1)The value of the insertion loss is the insertion loss minus the calculation value of 9 dB.

※(2)The V.S.W.R. is applicable to port #0, #1, #2, #3, #4, #5, #6, #7, and #8. (See the Dimensions Diagram for the port numbers.)

※(3)Applicable between the divider contacts.

## External Dimensions

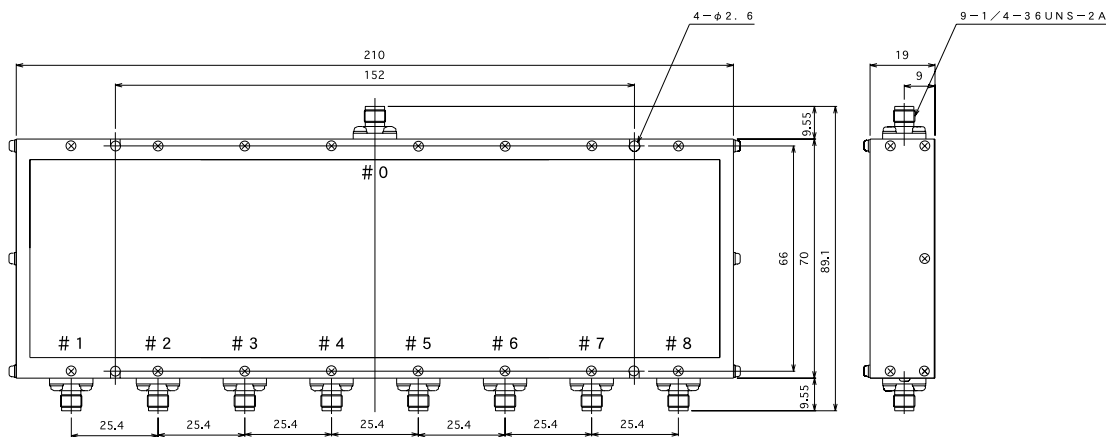

### PCB Mounting Pattern

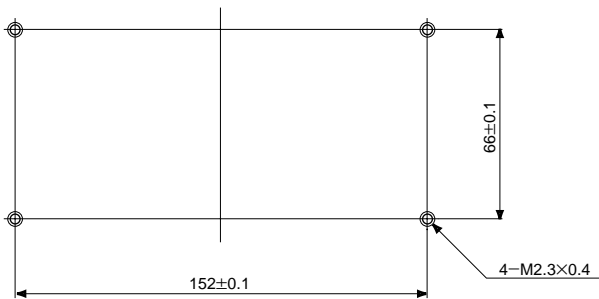

# 3WAY POWER COMBINER

## ■SPECIFICATION

Part Number	Frequency Range (GHz)	Insertion Loss (dB Max)	V.S.W.R. (Max)	Isolation (dB Min)	Power (W)	Weight (g)
3C-2000M-1	1.7~2.3	※(1) 0.5	※(2) 1.25	※(3) 22	1	135

※(1)The value of the insertion loss is the insertion loss minus the calculation value of 4.8 dB.

※(2)The V.S.W.R. is applicable to port #0, #1, #2, and #3. (See the Dimensions Diagram for the port numbers.)

※(3)Applicable between the divider contacts.

## ■External Dimensions

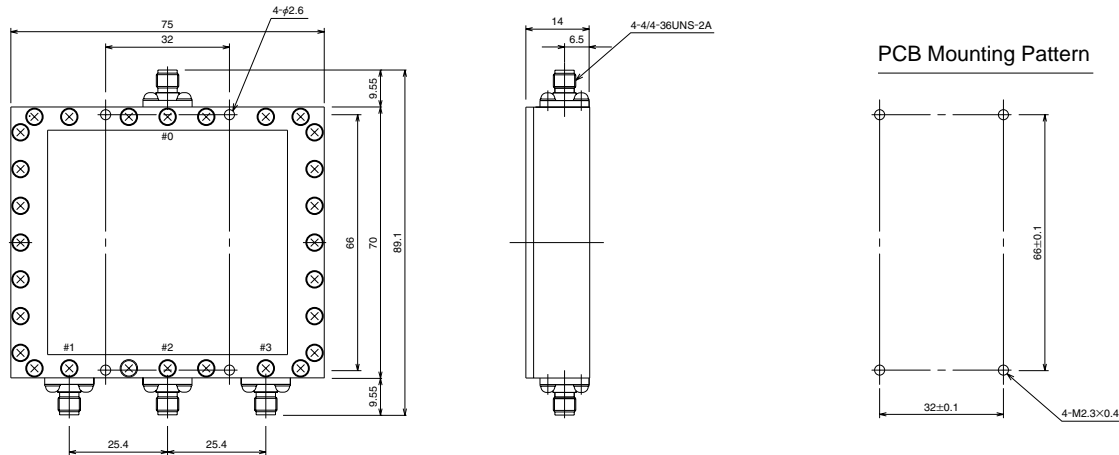

# 8WAY POWER COMBINER

## ■SPECIFICATION

Part Number	Frequency Range (GHz)	Insertion Loss (dB Max)	V.S.W.R. (Max)	Isolation (dB Min)	Power (W)	Weight (g)
8C-2000M-1	1.8~2.2	※(1) 1	※(2) 1.3	※(3) 20	2.5	240

※(1)The value of the insertion loss is the insertion loss minus the calculation value of 6 dB.

※(2)The V.S.W.R. is applicable to port #0, #1, #2, #3, #4, #5, #6, #7, and #8. (See the Dimensions Diagram for the port numbers.)

※(3)Applicable between the divider contacts.

## ■External Dimensions

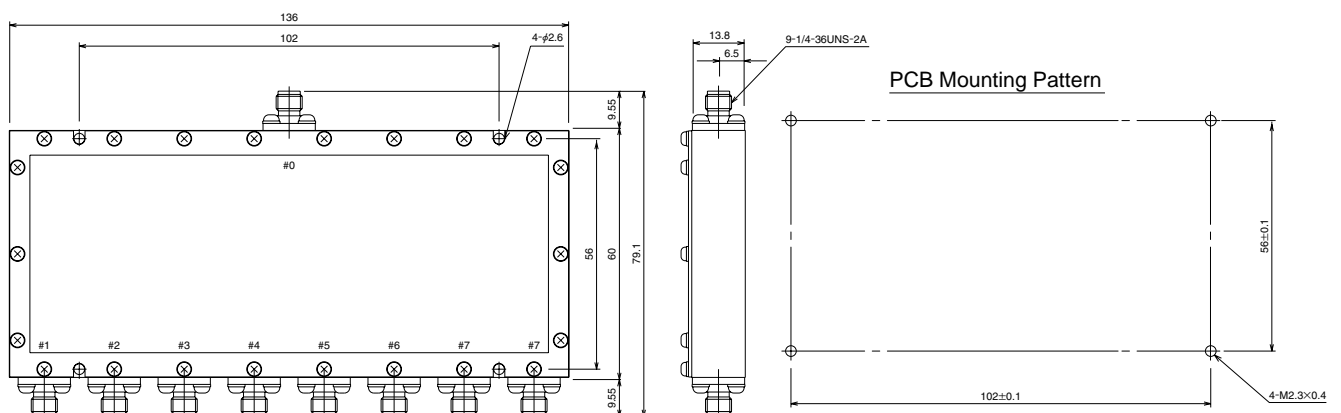

2D-2000M-1

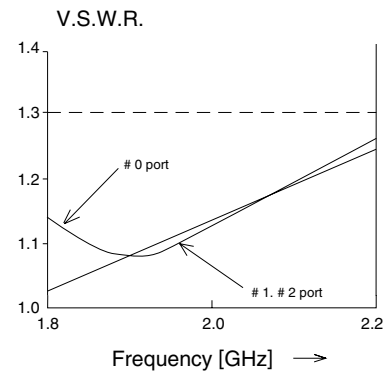
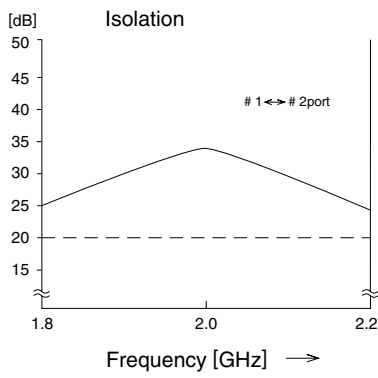
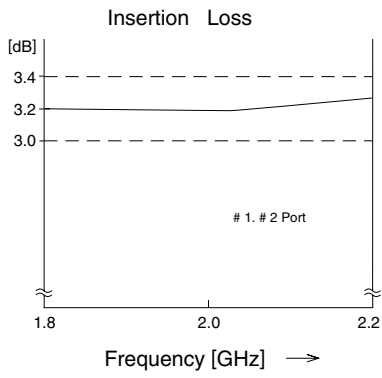

4D-2000M-1

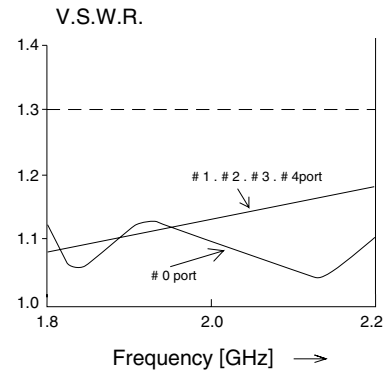
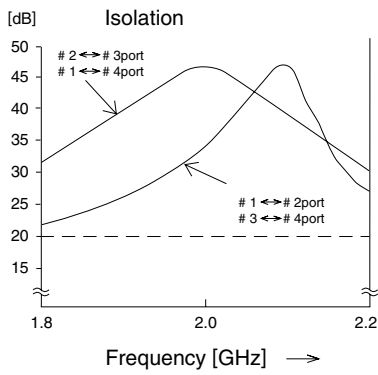
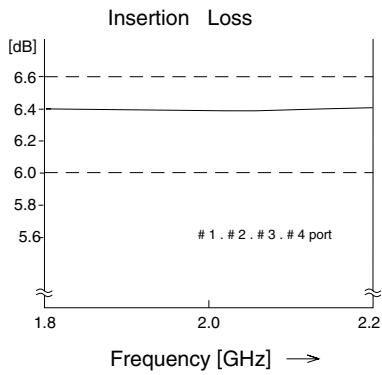

8D-2000M-1

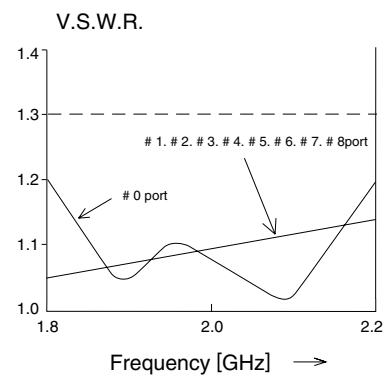
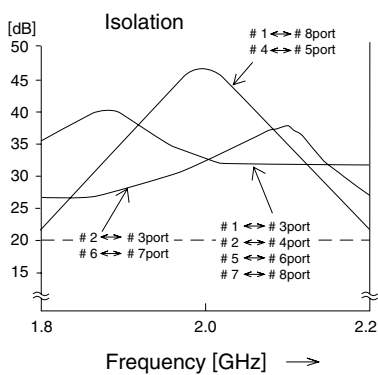
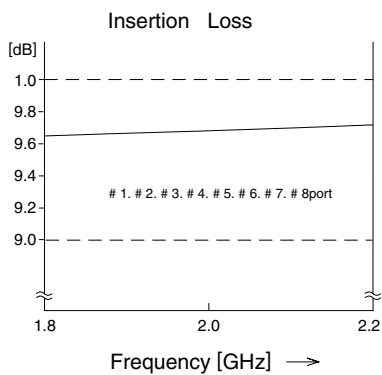

3C-2000M-1

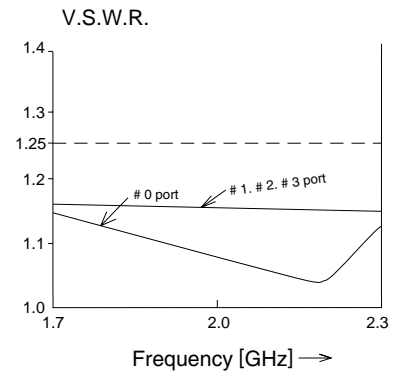
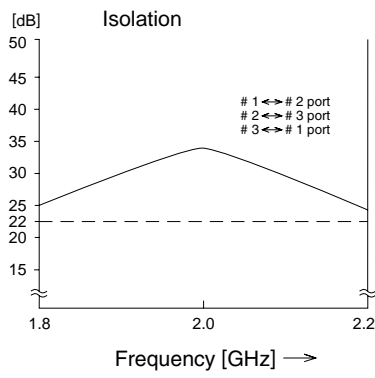
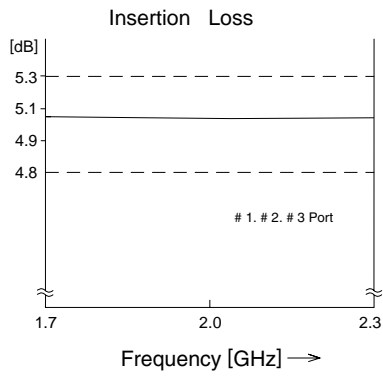

8C-2000M-1

