

600-mA Synchronous Buck Converter for 2-Cell Li+ Cellular Phones

FEATURES

- Voltage Mode Control
- 5-V to 10-V Input Voltage Range
- Fully Integrated 600-mA MOSFET Switches
- Synchronous Rectifier Switch
- Synchronizable, Constant-Frequency PWM Mode (up to 2 MHz)
- Programmable PWM/PSM Control
 - Up to 600-mA Output Current in PWM with 950- μ A Quiescent Current
 - Up to 150-mA Output Current in PSM with 200- μ A Quiescent Current
- Low Dropout Operation at Low $V_{IN} - V_{OUT}$
- Integrated UVLO, POR and OTP
- Integrated Soft-Start
- Shutdown Current $<1 \mu$ A
- Power Good Comparator

DESCRIPTION

The Si9167 provides a fully integrated synchronous buck converter solution for the latest 2-cell Lithium Ion battery cellular phones. Capable of delivering up to 600mA of output current, the Si9167 provides ample power for various Baseband circuits as well as for some PAs.

The Si9167 combines the 2-MHz switching frequency with fully integrated high-frequency MOSFETs to deliver the smallest and most efficient converter available today. The 2-MHz switching frequency reduces the inductor height to a new level of less than 2 mm and minimizes the output capacitance requirement to less than 10 μ F, with only 10-mV peak-to-peak output ripple.

Combined with its integrated low gate charge high-frequency MOSFETs and internal synchronous rectifier, the Si9167 delivers efficiency up to 95%. The programmable pulse-skipping mode maintains high efficiency even during the standby mode to increase overall battery life and talk time. In order to extract the last ounce of power from battery, Si9167 is designed with 100% duty cycle capability for both PSM and PWM operating modes. With 100% duty cycle, Si9167 operates like a saturated linear regulator to deliver the highest potential output voltage.

The Si9167 is available in TSSOP-20 pin package. In order to satisfy the stringent ambient temperature requirements, Si9167 is specified over the industrial temperature range of -25°C to 85°C .

FUNCTIONAL BLOCK DIAGRAM

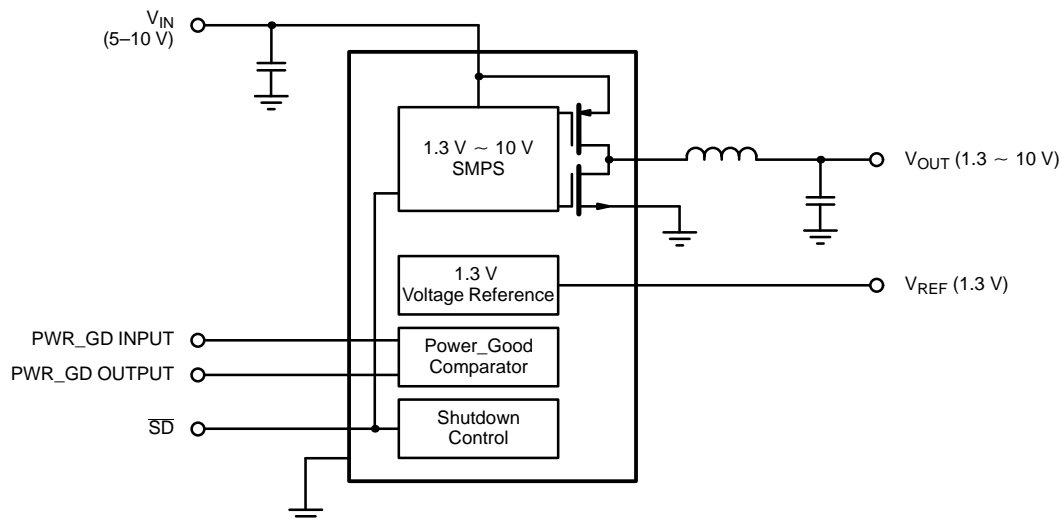



ABSOLUTE MAXIMUM RATINGS

Voltages Referenced to AGND		Continuous Output Current	1 A
V _{DD}	13 V	Storage Temperature	-65 to 150°C
PWM/PSM, SYNC, CLK, \overline{SD} , AIN, AO, V _{REF} , R _{OSC} , COMP, FB	-0.3 V to V _{DD} + 0.3 V	Operating Junction Temperature	150°C
V _O	-0.3 V to V _S + 0.3 V	Power Dissipation (Package) ^a	
PGND	±0.3 V	20-Pin TSSOP (Q Suffix) ^b	1.56 W
Voltages Referenced to PGND		Thermal Impedance (Θ_{JA})	
V _{IN}	13 V	20-Pin TSSOP	.80°C/W
COIL	-0.4 V to V _{IN} + 0.4 V	Notes	
Peak Output Current	3 A	a. Device mounted with all leads soldered or welded to PC board.	
		b. Derate 12.5 mW/°C above 25°C.	

Stresses beyond those listed under "Absolute Maximum Ratings" may cause permanent damage to the device. These are stress ratings only, and functional operation of the device at these or any other conditions beyond those indicated in the operational sections of the specifications is not implied. Exposure to absolute maximum rating conditions for extended periods may affect device reliability.

RECOMMENDED OPERATING RANGE

Voltages Referenced to GND		PWM/PSM, SYNC, \overline{SD}	0 V to V _{DD}
V _{DD}	5 V to 10 V	V _{REF} Capacitor	.01 μ F
Oscillator Frequency	200 kHz to 2 MHz	Voltages Referenced to PGND	
R _{OSC}	20 k Ω to 300 k Ω	V _{IN}	.5 V to 10 V
V _{OUT}	1.3 to 10 V		

SPECIFICATIONS						
Parameter	Symbol	Test Conditions Unless Otherwise Specified 5 V \leq V _{DD} \leq 10 V, V _{IN} = V _{DD}	Limits -25°C to 85°C			Unit
			Min ^a	Typ ^b	Max ^a	
Reference						
Output Voltage	V _{REF}	I _{REF} = 0	1.2675	1.3	1.3325	V
		V _{DD} = 7.2 V, I _{REF} = 0, 25°C	1.280	1.3	1.320	
V _{REF} Current	I _{REF}			-0.5		mA
V _{REF} PSRR	P _{SRR}			60		dB
UVLO						
Under Voltage Lockout (Turn-On)			4.25	4.5	4.75	V
Hysteresis				0.2		
Soft-Start Time						
SS Time	t _{SS}			10		ms
SD, SYNC, PWM/PSM						
Logic High			2.4			V
Logic Low					0.8	



SPECIFICATIONS						
Parameter	Symbol	Test Conditions Unless Otherwise Specified $5\text{ V} \leq V_{DD} \leq 10\text{ V}, V_{IN} = V_{DD}$	Limits -25°C to 85°C			Unit
			Min ^a	Typ ^b	Max ^a	
Oscillator						
Maximum Frequency	F_{MAX}				2	MHz
Accuracy		1% External Resistor	-20		20	%
Maximum Duty Cycle (Non LDO Mode)	D_{MAX}	$F_{SW} = 2\text{ MHz}$		80		
SYNC Range	F_{SYNC}/F_{OSC}	$F_{SYNC} \leq 2\text{ MHz}$	1.2	1.5		
SYNC Low Pulse Width			50			ns
SYNC High Pulse Width			50			
SYNC t_r, t_f	t_r, t_f	(10% to 90%)			50	
Error Amplifier						
Input Regulation Range	V_{FB}		1.260		1.340	V
Input Bias Current	I_{BIAS}	$V_{FB} = 1.4\text{ V}$	-1		1	μA
Open Loop Voltage Gain	A_{VOL}		50	60		dB
Power Supply Rejection	P_{SRR}			60		
Unity Gain BW	BW			2		MHz
Output Current (Source)	I_{EA}	$V_{FB} = 1.05\text{ V}$		-2	-0.5	mA
Output Current (Sink)		$V_{FB} = 1.55\text{ V}$	1	2		
PSM Modulator						
Inductor Peak Current	I_{PEAK}	$V_{DD} = 7.2\text{ V}, V_{OUT} = 3.3\text{ V}$		500		mA
Output Capability						
PWM Mode Output ^c	I_{OUT}	$V_{DD} = V_{IN} = 7.2\text{ V}, V_{OUT} = 3.3\text{ V}$	600			mA
PSM Mode Output ^c			150			
$r_{DS(ON)}$ High Side	$r_{DS(ON-P)}$	$V_{DD} = V_{IN} = 7.2\text{ V}$			300	$m\Omega$
$r_{DS(ON)}$ Low Side	$r_{DS(ON-N)}$				300	
Over Temperature Protection						
Trip Point				165		°C
Hysteresis				25		
Supply Current						
PWM Mode		$V_{DD} = V_{IN} = 7.2\text{ V}$ $F_{OSC} = 1.6\text{ MHz}$		950	1350	μA
PSM Mode				200	350	
Shutdown Mode					1	
Power Good Comparator						
POKIN Trip Level		Rising V_{POKIN}	1.270	1.300	1.330	V
POKIN Input Current			-20		20	nA
POKIN Hysteresis			30	50		mV
POK Low Voltage		$I_{SINK(POK)} = 1\text{ mA}$			0.4	V
POK High Leakage Current				0.001	1	μA

Notes

- a. The algebraic convention whereby the most negative value is a minimum and the most positive a maximum, is used in this data sheet.
- b. Typical values are for DESIGN AID ONLY, not guaranteed or subject to production testing.
- c. Guaranteed by design and characterization, not subject to production testing.



TYPICAL CHARACTERISTICS (25°C UNLESS NOTED)

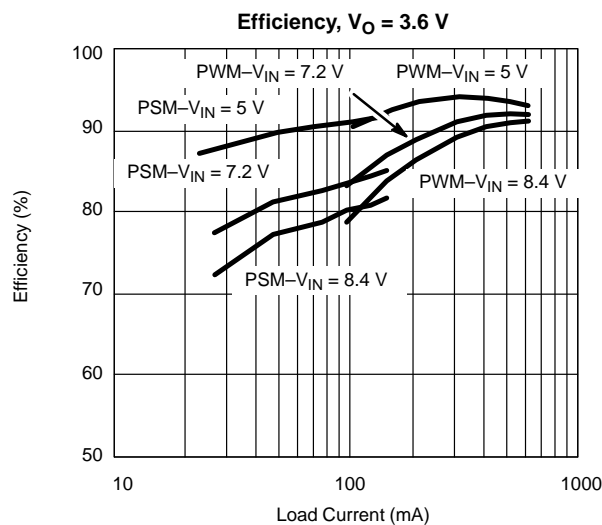
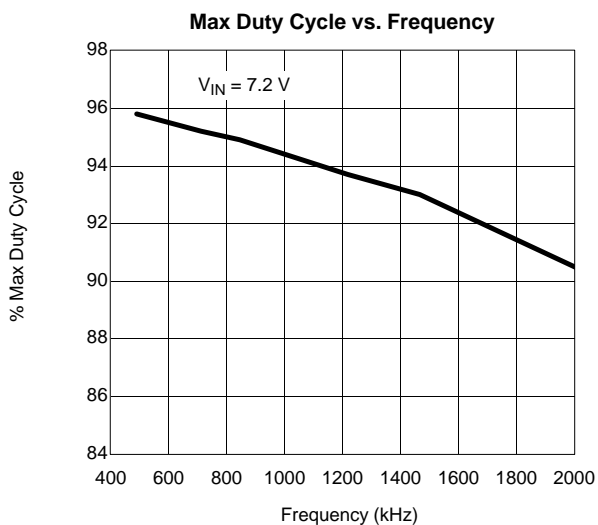
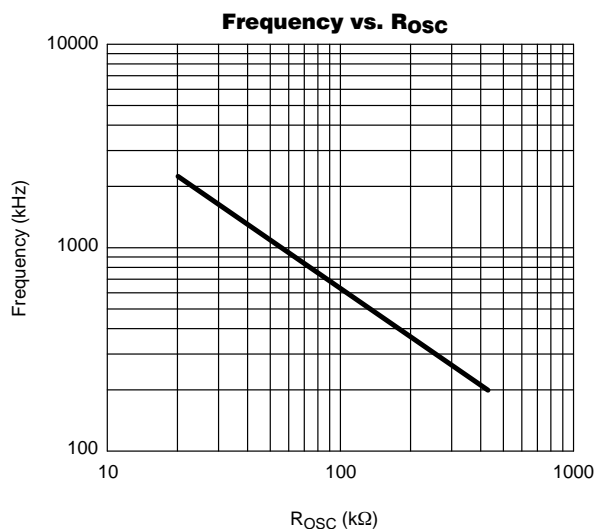
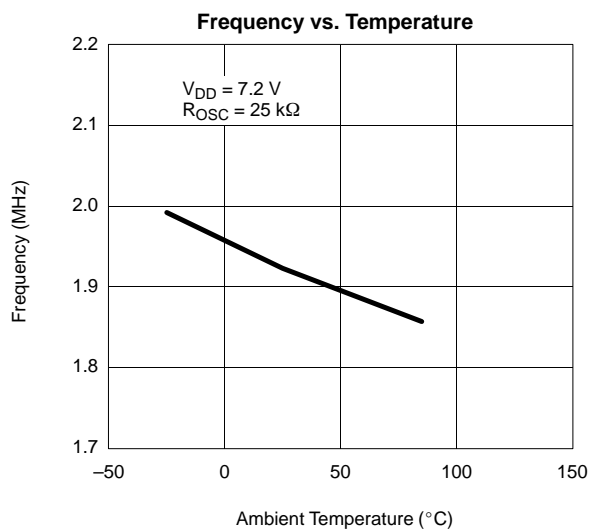
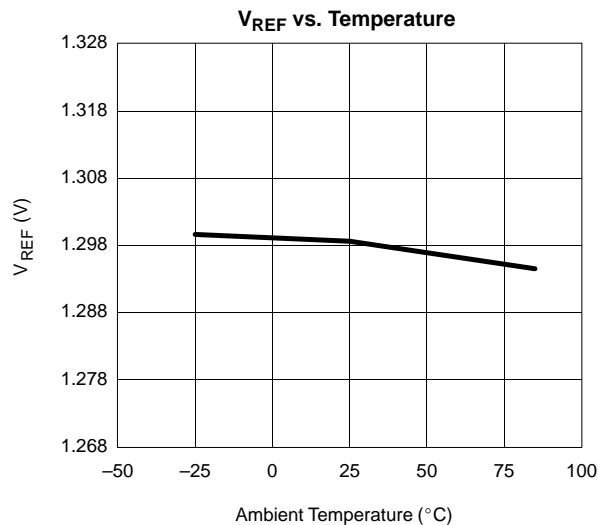
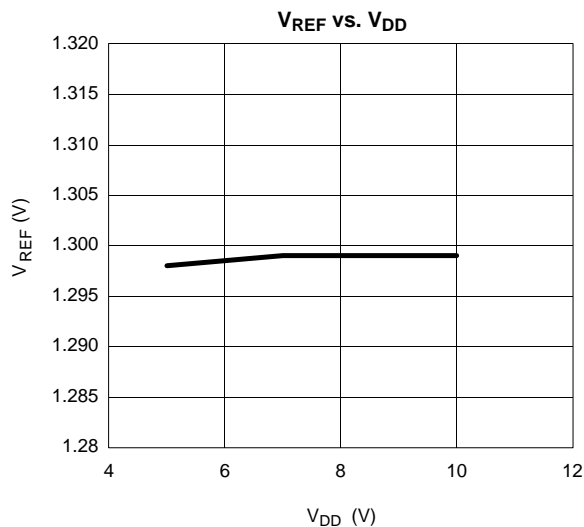

TYPICAL CHARACTERISTICS (25°C UNLESS NOTED)

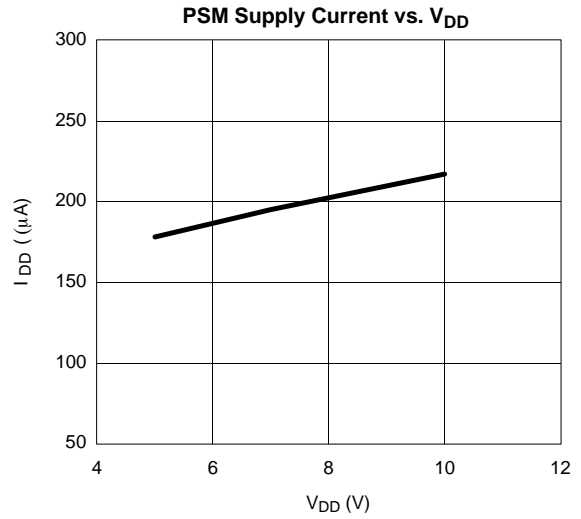
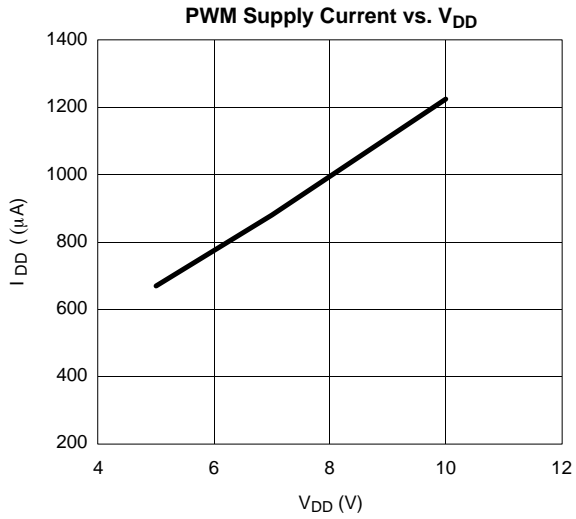

TYPICAL WAVEFORMS

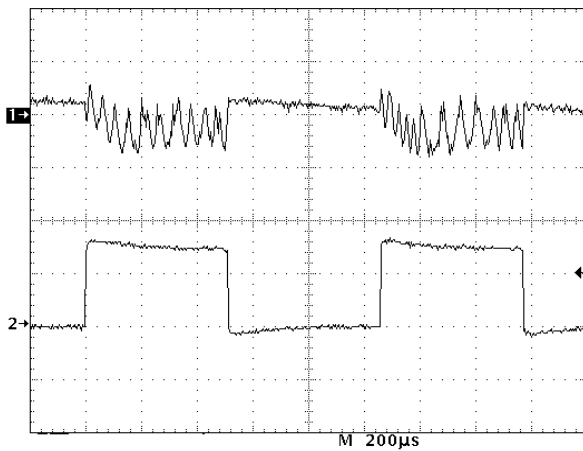

V_{IN} = 7.2 V, V_O = 3.6 V, Step I_O = 0 to 150 mA
 Step Load Slew Rate = 1 A/μsec
 Ch1: V_{OUT} (50 mV/div)
 Ch2: I_{OUT} (100 mA/div)

FIGURE 1. Transient Response PSM Mode

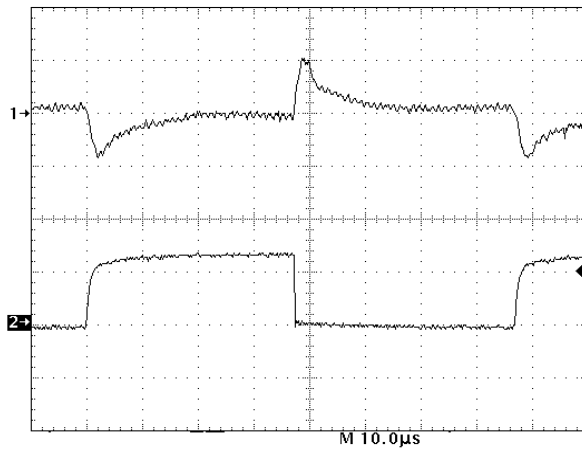
TYPICAL WAVEFORMS

FIGURE 2. Transient Response PWM Mode

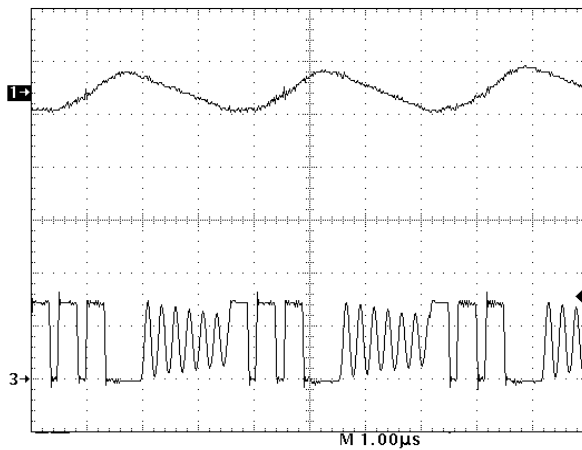
$V_{IN} = 7.2 \text{ V}$, $V_O = 3.6 \text{ V}$, Step $I_O = 0$ to 600 mA
 Step Load Slew Rate = $1 \text{ A}/\mu\text{sec}$
 Ch1: V_{OUT} (100 mV/div)
 Ch2: I_{OUT} (500 mA/div)

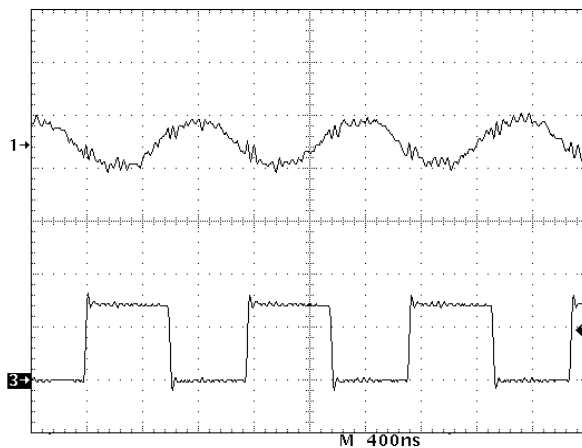
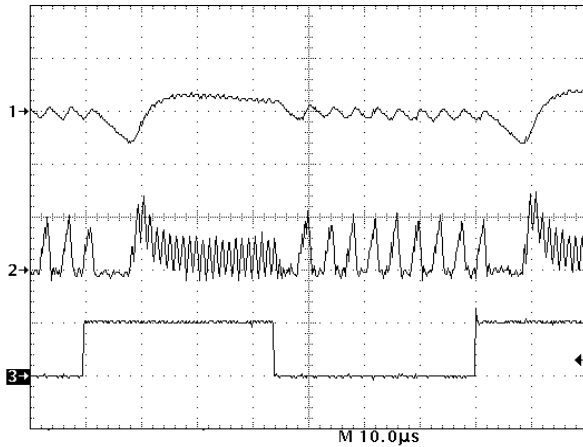

FIGURE 3. PSM Output Ripple

$V_{IN} = 7.2 \text{ V}$, $V_O = 3.6 \text{ V}$, $I_O = 150 \text{ mA}$
 Ch1: V_{OUT} (50 mV/div)
 Ch3: Coil (5 V/div)

FIGURE 4. PWM Output Ripple

$V_{IN} = 7.2 \text{ V}$, $V_O = 3.6 \text{ V}$, $I_O = 600 \text{ mA}$
 Ch1: V_{OUT} (10 mV/div)
 Ch3: Coil (5 V/div)

TYPICAL WAVEFORMS



$V_{IN} = 7.2\text{ V}$, $V_O = 3.6\text{ V}$, $I_O = 150\text{ mA}$
 Ch1: V_{OUT} (200 mV/div)
 Ch2: Inductor Current (500 mA/div)
 Ch3: PWM/PSM (High PWM, Low PSM)

FIGURE 5. PSM-PWM-PSM Transition

PIN CONFIGURATION

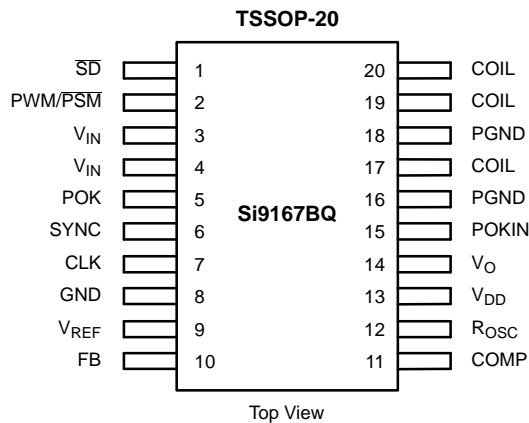

ORDERING INFORMATION

Part Number	Temperature Range	Package
Si9167BQ-T1	-25 to 85°C	Tape and Reel

Eval Kit	Temperature Range	Board Type
Si9167DB	-25 to 85°C	Surface Mount

PIN DESCRIPTION

Pin Number	Name	Function
1	\overline{SD}	Shuts down the IC completely and decreases current consumed by the IC to $<1\ \mu\text{A}$.
2	PWM/PSM	Logic high = PWM mode, logic low = PSM mode.
3, 4	V_{IN}	Input node for buck converter as well as input supply voltage for the internal MOSFET gate drive voltage.
5	POK	Power_good comparator output, It sinks current when $V_{POKIN} < 1.3\text{ V}$, high Impedance state during disable.
6	SYNC	Externally controlled synchronization signal. Logic high to low transition forces the clock synchronization.
7	CLK	Oscillator output
8	GND	Analog ground
9	V_{REF}	1.3-V reference. Bypassed with 0.1- μF capacitor.
10	FB	Output voltage feedback
11	COMP	Error amplifier output for external compensation network
12	R_{OSC}	External resistor to set the switching frequency
13	V_{DD}	Supply voltage for the control circuit
14	V_O	Direct output voltage sense
15	POKIN	Power_good comparator input
16, 18	PGND	Power ground
17, 19, 20	COIL	Inductor connection node

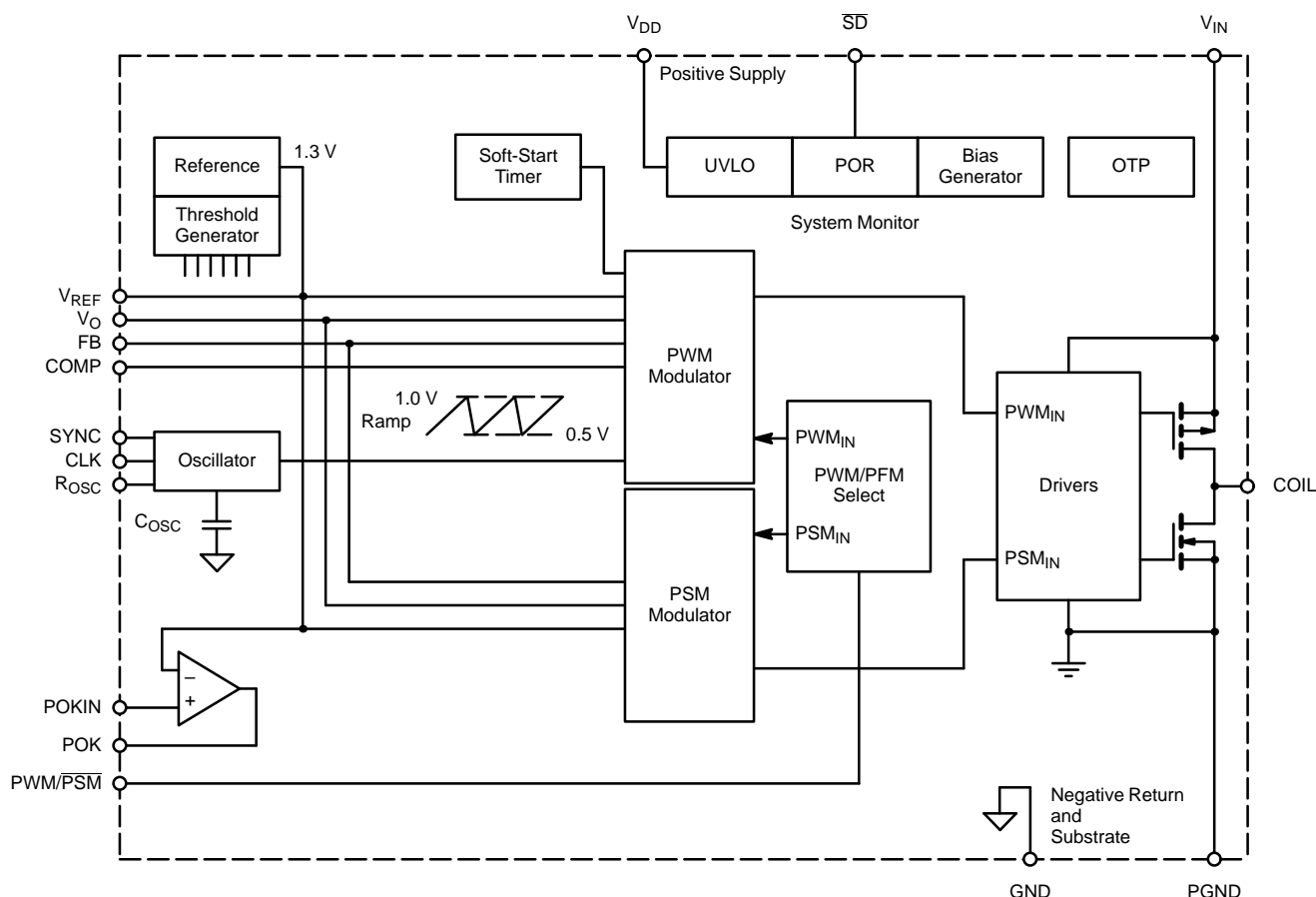
BLOCK DIAGRAM

FIGURE 1.
DETAIL OPERATIONAL DESCRIPTION
UVLO

The UVLO circuit prevents the internal MOSFET switches and oscillator circuit from turning on, when the input voltage is too low to regulate output voltage. Failing to do this could unintentionally lock up the system. The typical turn on threshold is 4.5 V with a turn off hysteresis of 0.2 V.

STARTUP

Once the input voltage is above the turn on threshold, and with no other shutdown condition detected, the system enters a POR (power on reset) phase, which lasts about 1 ms. During this POR phase, most of the circuits are activated, except for the power switches. After the POR phase, an internal soft-start

circuit slowly regulates the output voltage from 0 V to its intended level. This soft-start phase typically lasts for 3 ms.

Note that the Si9167 always soft-starts in the PWM mode regardless of the voltage level on the PWM/PSM pin.

Shutdown

The Si9167 is designed to conserve as much battery life as possible by decreasing current consumption of the IC during normal operation as well as in the shutdown mode. With logic low level on the \overline{SD} pin, current consumption of the Si9167 is decreased to less than $1\ \mu\text{A}$ by shutting off most of the circuits. The logic high enables the converter and starts up as described in "Start-Up" section above.



DETAIL OPERATIONAL DESCRIPTION

Over Temperature Protection

The Si9167 is designed with an over temperature protection circuit to prevent the MOSFET switches from overheating. If the temperature reaches 165°C, internal soft-start capacitor is discharged, shutting down the output stage. The converter remains in the disabled mode until the temperature in the IC decreases below 140°C.

PWM Mode

With PWM/ $\overline{\text{PSM}}$ pin pulled logic high, Si9167 operates in constant frequency (PWM) mode. The converter regulates the output voltage by modulating the MOSFET switch duty cycle. Switching harmonics generated by fixed-frequency operation are consistent and easy to filter. The switching frequency is programmed by the R_{OSC} value as shown by the oscillator curve. In the PWM mode, the synchronous switch is always enabled, which permits the converter to run in continuous current mode, even when the output current reaches 0 A. In continuous current mode, the transfer function of the converter remains constant, providing fast transient response. If the converter operates in discontinuous current mode, overall loop gain decreases and transient response time can be ten times longer than if the converter remains in continuous current mode. This transient response time advantage can significantly decrease the size of the hold-up capacitors needed on the output of dc-dc converter to meet the transient voltage regulation.

The Si9167 can operate at 100% duty cycle, when it operates like a saturated linear regulator. This allows the system designers to extract out the maximum stored energy from the battery. As input voltage drops close to output regulation level, the converter will approach maximum switching duty cycle, about 80%, at full switching frequency. As input voltage further decreases, the converter will enter 100% duty cycle mode. This instantaneous jump in duty cycle is due to BBM time and the internal propagation delays. In order to maintain regulation, the converter might change its duty cycle back and forth from 100% to maximum switching duty cycle during this input voltage range. If the input voltage drops further, the converter will remain at 100% duty cycle. If the input voltage increases to a point where it requires less than maximum duty cycle, about 80%, the converter will resume normal PWM operation.

Pulse Skipping Mode

Gate charge losses of MOSFETs can be the dominant power dissipation during light load (i.e. <10 mA) if the converter is switching at high frequency. With PWM/ $\overline{\text{PSM}}$ pin pulled logic low, the Si9167 operates in PSM mode. During this mode, the converter switching frequency is lower than PWM switching frequency in order to achieve high power efficiency at light load. By building up inductor current to a fixed level during each cycle, the converter regulates the output voltage with variable switching frequency, depending on the operating condition.

During PSM mode, a comparator detects the output voltage out of regulation and sets up a charging cycle. Depending upon the input to output voltage difference, the high-side MOSFET is on for certain amount of time and off for a shorter duration. This on-off cycle continues until the output voltage rises above the target level. The comparator detects this condition and idles the converter until the output falls under the converter output regulation level. Here, the comparator initializes another charge cycle. During the idle time, when both switches are off, the load is supplied by the output capacitor.

When the input voltage approaches the programmed output voltage the converter operates as a saturated linear regulator. If the input voltage is lower than the programmed output voltage then the converter operates in a 100% duty cycle mode such that the output voltage will closely follow the input voltage.

REF

The reference voltage of the Si9167 is set at 1.3 V. The reference voltage is internally connected to the non-inverting inputs of the error amplifier. The reference voltage output is bypassed by 0.1- μF capacitor.

Error Amplifier

In order to establish high-speed system response, the Si9167 is designed with 2-MHz error amplifier to generate the widest converter bandwidth and 3.5-V/ μs slew rate for fast large signal response.

Oscillator

The oscillator is designed to operate up to 2-MHz minimal. The 2-MHz operating frequency allows the converter to minimize the inductor and capacitor size, improve the power density of the converter. Attaching a resistor to R_{OSC} pin easily programs the switching frequency. See oscillator frequency versus R_{OSC} curve to select the proper values for desired operating frequency. The tolerance on the operating frequency is $\pm 20\%$ with 1% tolerance resistor.

Synchronization

The synchronization with external clock is easily accomplished by connecting the external clock into the SYNC pin. Logic high to low transition synchronizes the clock. The external clock frequency must be within 1.2 to 1.5 times the internal clock frequency.

CLK Output

During PWM mode, CLK pin provides oscillator signal for users to synchronize other converters in order to set the harmonics to avoid IF bands in wireless applications. This is accomplished by connecting CLK of the master to Sync of the slave.

DETAIL OPERATIONAL DESCRIPTION

Break-Before-Make Timing

A proper BBM time is essential in order to prevent shoot-through current and maintain high efficiency. The break-before-make time is set internally at 20 to 40 ns @ $V_{DD} = 7.2$ V. After one switch (either high-side or low-side) is turned off, 20- to 40-ns BBM time is set before the other switch turns on. The maximum and minimum controllable duty cycle is primarily limited by the BBM time. Since the BBM time is fixed, maximum controllable duty cycle will vary depending on the switching frequency. Typically, the higher the PWM switching frequency, the lower the maximum duty cycle and the higher the minimum duty cycle.

Output MOSFET Stage

The high and low-side switches are integrated to provide optimum performance and to minimize the overall converter

size. Both high and low-side switches are designed to handle up to 600 mA of continuous current. The MOSFET switches were designed to minimize the gate charge loss as well as the conduction loss. For high frequency operation, switching losses can exceed conduction loss, if the switches are designed incorrectly. Under full load, efficiency of up to 95% is accomplished with 7.2-V battery voltage (3.3-V output voltage).

Power Good Comparator

The Si9167 has an uncommitted power good comparator. This comparator has its negative input connected directly to 1.3-V reference and has a typical hysteresis of 50 mV at room temperature. Its output is an open-drain n-channel MOSFET capable of sinking 1 mA. This output is open circuit in the shutdown mode.

STANDARD APPLICATION

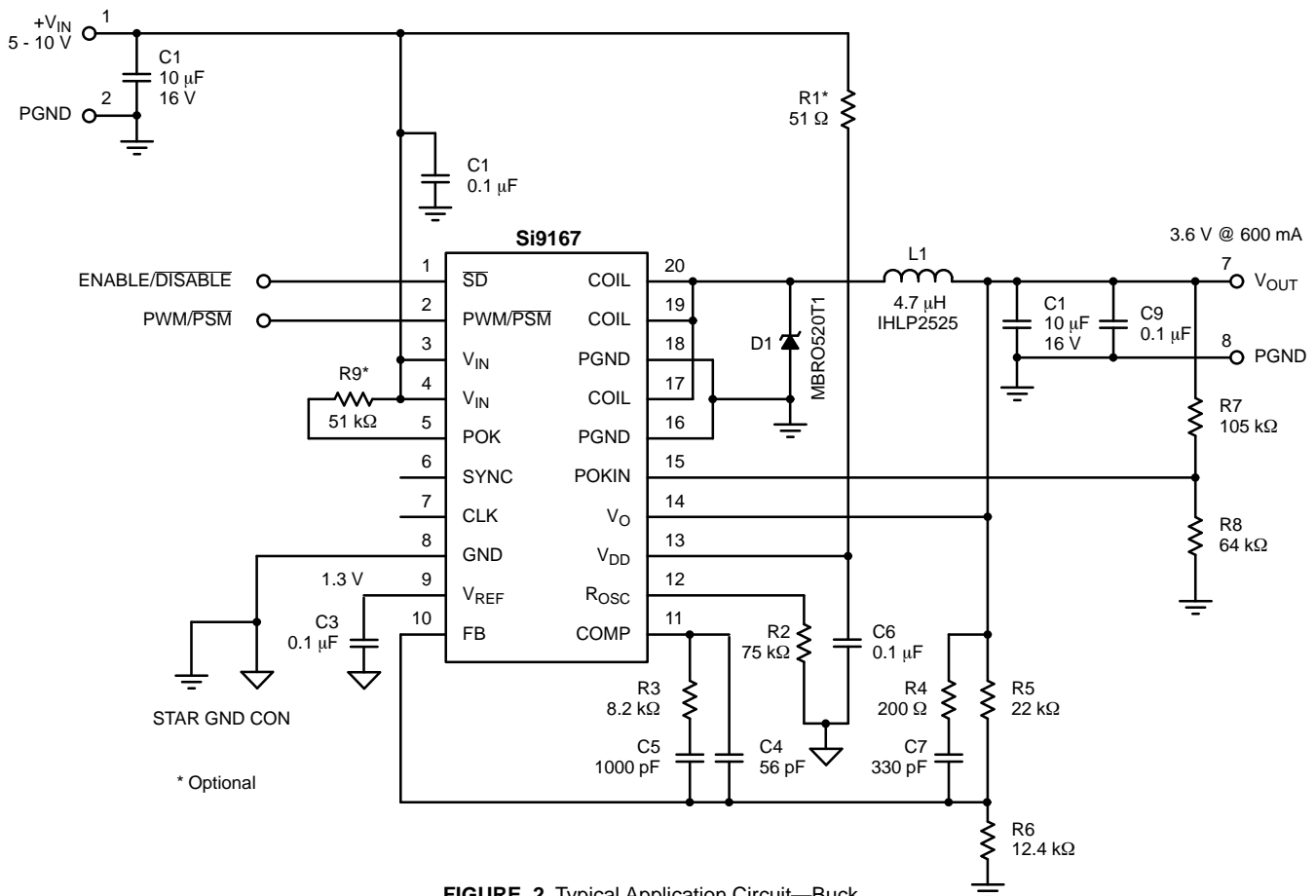

FIGURE 2. Typical Application Circuit—Buck