

## 16Mb SDRAM

- 3.3 volt 1Mx16
- 100/143 MHz SDRAM
- 2 banks, 4K refresh

## GENERAL DESCRIPTION

The VT361716T is a high-speed synchronous dynamic random access memory (SDRAM), organized as 512K words x 2 banks x 16 bits. Using pipelined architecture technology. Accesses to the SDRAM are burst oriented. Consecutive memory location in one page can be accessed at a burst length of 1,2,4,8 or full page when a bank and row is selected by an ACTIVE command. By having a programmable Mode Register, the system can change burst length, latency cycle, interleave or sequential burst to maximize its performance.

## FEATURES

- 3.3V  $\pm$  0.3V power supply
- 524,288 words x 2 banks x 16 bits organization
- Two banks operation
- Power-down Mode
- Sequential and interleave burst
- Burst Length: 1,2,4,8 and full page
- CAS latency: 2 and 3
- 4K refresh cycles/64 ms
- Auto & self refresh
- DQM for masking
- Burst read single-bit write operation
- LVTTL compatible with multiplexed address
- All inputs are sample at the positive going edge of the system clock

**PIN CONFIGURATION (Top view)**

50-Pin Plastic TSOP ( II ) ( 400mil )

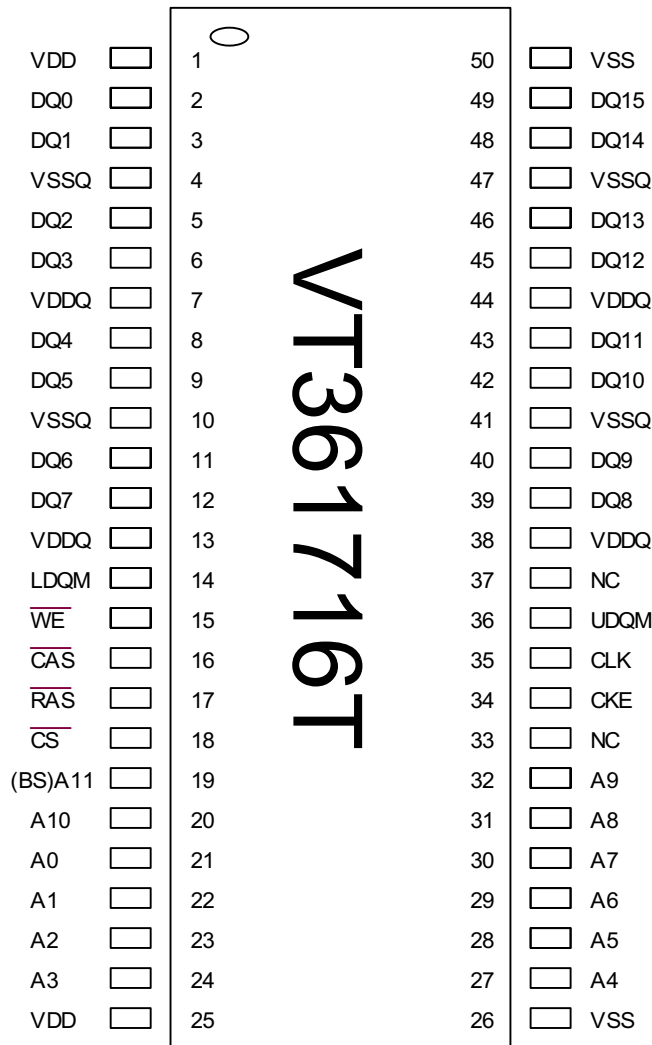

## PIN DESCRIPTION

PIN NAME	FUNCTION	DESCRIPTION
A <sub>0</sub> - A <sub>10</sub>	Address	Multiplexed pins for row and column address. Row address: A <sub>0</sub> -A <sub>10</sub> . Column address: A <sub>0</sub> -A <sub>7</sub> .
A <sub>11</sub> (BS)	Bank Select	Select bank to activate during row address latch time, or bank to read/write during address latch time.
DQ <sub>0</sub> - DQ <sub>15</sub>	Data Input / Output	Multiplexed pins for data output and input.
/CS	Chip Select	Disable or enable the command decoder.
/RAS	Row Address Strobe	Latches row addresses on the positive going edge of the CLK with /RAS low.
/CAS	Column Address Strobe	Latches column addresses on the positive going edge of the CLK with /CAS low.
/WE	Write Enable	Enables write operation and row precharge.
DQM	Input/output mask	Makes data output Hi-z. Blocks data input when DQM active.
CLK	Clock Inputs	System clock used to sample inputs on the rising edge of clock.
CKE	Clock Enable	CKE controls the clock activation and deactivation. When CKE is low, Power Down mode, Suspend mode or Self Refresh mode is entered.
V <sub>DD</sub>	Power (+3.3V)	Power for input buffers and logic circuit inside DRAM.
V <sub>SS</sub>	Ground	Ground for input buffers and logic circuit inside DRAM.
V <sub>DDQ</sub>	Power (+3.3V) for I/O buffer	Separated power from V <sub>DD</sub> , to improve DQ noise immunity.
V <sub>SSQ</sub>	Ground for I/O buffer	Separated power from V <sub>SS</sub> , to improve DQ noise immunity.
NC	No Connection	No Connection

BLOCK DIAGRAM

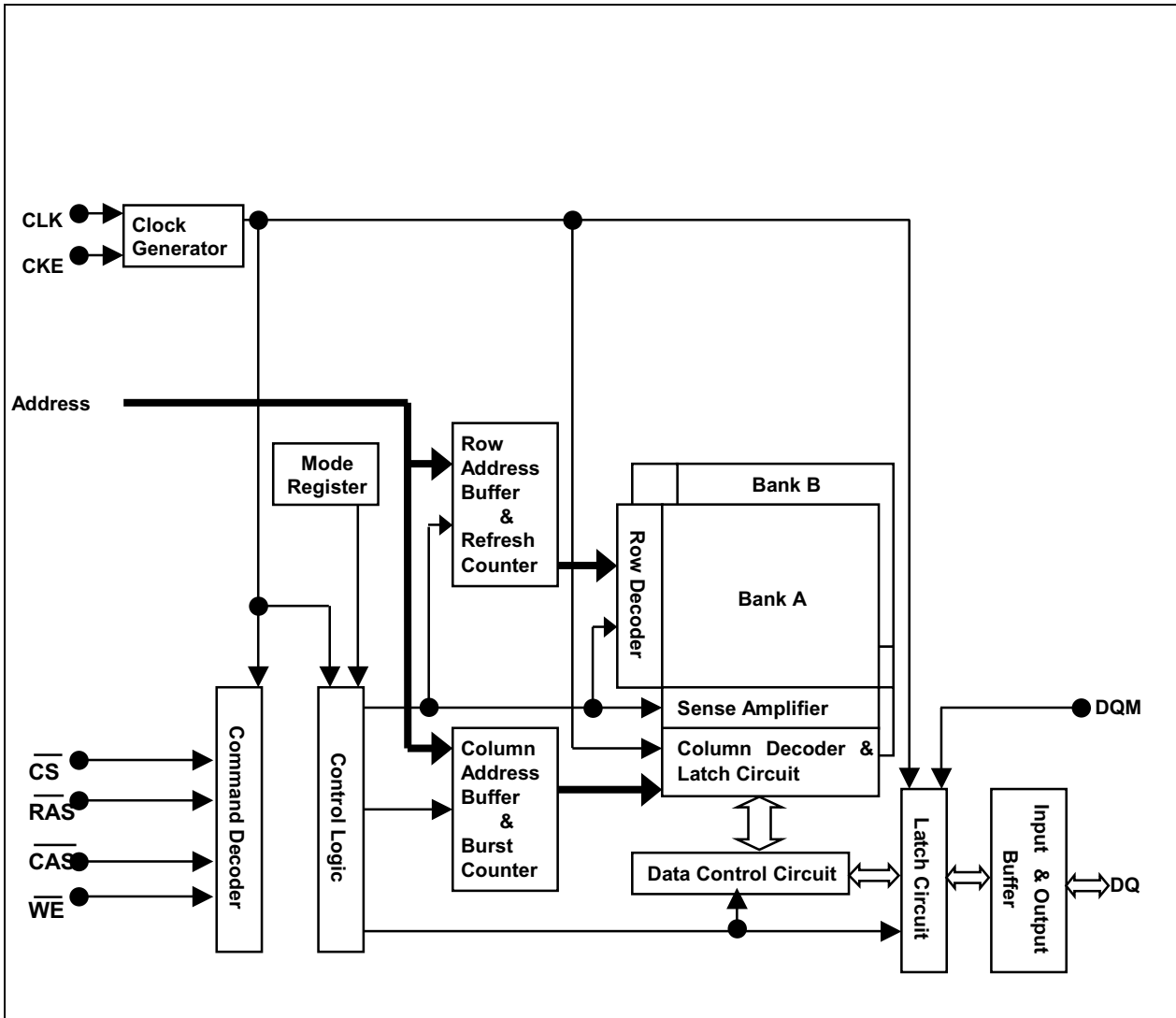

**ABSOLUTE MAXIMUM RATINGS**

PARAMETER	SYMBOL	VALUE	UNIT
Voltage on any pin relative to $V_{SS}$	$V_{IN}, V_{OUT}$	-0.3 to +3.6	V
Supply voltage relative to $V_{SS}$	$V_{DD}, V_{DDQ}$	-0.3 to +3.6	V
Short circuit current	$I_{OS}$	50	mA
Power dissipation	PD	1.0	W
Operating temperature	$T_{OPT}$	0 to +60	°C
Storage temperature	$T_{STG}$	-55 to +125	°C

**DC OPERATING CONDITIONS AND CHARACTERISTICS**

Recommended DC operating conditions (Voltage referenced to  $V_{SS} = 0V$ ,  $T_A = 0$  to  $70^{\circ}C$ )

PARAMETER	SYMBOL	MIN	TYP	MAX	UNIT	NOTE
Supply voltage	$V_{DD}$	3.0	3.3	3.6	V	
Input high voltage	$V_{IH}$	2.0		$V_{DD}+0.3$	V	
Input low voltage	$V_{IL}$	-0.3		0.8	V	

**CAPACITANCE** ( $V_{DD}=3.3V$ ,  $T_A=25^{\circ}C$ ,  $f=1MHz$ ,  $V_{REF}=1.4V+200mV$ )

PARAMETER	SYMBOL	TYP	MAX	UNIT
Input capacitance ( $A_0 - A_{10}, BS$ )	$C_{IN1}$	2.5	5	Pf
Input capacitance ( $/RAS, /CAS, /WE$ )	$C_{IN2}$	2.5	5	Pf
Input capacitance (CKE)	$C_{IN3}$	2.5	5	Pf
Input capacitance (CLK)	$C_{IN4}$	2.5	5	Pf
Input capacitance ( $/CS$ )	$C_{IN5}$	2.5	5	Pf
Input capacitance (DQM)	$C_{IN6}$	2.5	5	Pf
Data input/output capacitance ( $DQ_0 - DQ_{15}$ )	$C_{I/O}$	4.0	6.5	Pf

## TABLE OF OPERATING MODES

### COMMAND TRUTH TABLE

FUNCTION	SYMBOL	CKE		/CS	/RAS	/CAS	/WE	BA	A10	A9 - A0
		n-1	N							
Device deselect	DESL	H	X	H	X	X	X	X	X	X
No operation	NOP	H	X	L	H	H	H	X	X	X
Mode register set	MRS	H	X	L	L	L	L	L	L	V
Bank activate	ACT	H	X	L	L	H	H	V	V	V
Read	READ	H	X	L	H	L	H	V	L	V
Read with auto precharge	READA	H	X	L	H	L	H	V	H	V
Write	WRIT	H	X	L	H	L	L	V	L	V
Write with auto precharge	WRITA	H	X	L	H	L	L	V	H	V
Precharge select bank	PRE	H	X	L	L	H	L	V	L	X
Precharge all banks	PALL	H	X	L	L	H	L	X	H	X
Burst stop	BST	H	X	L	H	H	L	X	X	X
CBR (Auto) refresh	REF	H	H	L	L	L	H	X	X	X
Self refresh	SELF	H	L	L	L	L	H	X	X	X
Data mask/output disable	MASK	H	X	X	X	X	X	X	X	X
Clock suspend mode entry		H	L	X	X	X	X	X	X	X
Clock suspend		L	L	X	X	X	X	X	X	X
Clock suspend mode exit		L	H	X	X	X	X	X	X	X
Power down entry		H	L	X	X	X	X	X	X	X
Power down exit		L	H	X	X	X	X	X	X	X

H:High level, L:Low level

X:High or Low level (Don't care), V: Valid Data input

**AC CHARACTERISTICS AND OPERATING CONDITION**(V<sub>CC</sub>=3.3V±0.3V, Ta=0° to 70°C Notes : 5,6,7)

SYMBOL	PARAMETER	-6 (143MHz)		-7 (100MHz)		UNITS
		MIN	MAX	MIN	MAX	
t <sub>RC</sub>	Ref/Active to Ref/Active Command Period	63		72		ns
t <sub>RAS</sub>	Active to precharge Command Period	42	100K	50	100K	
t <sub>RCD</sub>	Active to Read/Write Command Delay Time	20		20		
t <sub>CCD</sub>	Read/Write(a) to Read/Write(b) Command	1		1		cycle
t <sub>RP</sub>	Precharge to Active(b) Command Period	20		20		ns
t <sub>R RD</sub>	Active(a) to Active(b) Command Period	14		20		
t <sub>CK</sub>	CLK Cycle Time	7		10		
t <sub>CH</sub>	CLK High Level	2.5		3		
t <sub>CL</sub>	CLK Low Level	2.5		3		
t <sub>AC</sub>	Access Time from CLK		6		7	
t <sub>OH</sub>	Output Data Hold Time	2.5		3		
t <sub>HZ</sub>	Output Data High Impedance Time		5		5	
t <sub>LZ</sub>	Output Data Low Impedance Time	1		0		
t <sub>SB</sub>	Power Down Mode Entry Time	5				
t <sub>T</sub>	Transition Time of CLK(Rise and Fall)	0.5	10	1	10	
t <sub>DS</sub>	Data-in-Set-up Time	2		2		
t <sub>DH</sub>	Data-in Hold Time	1		1		
t <sub>AS</sub>	Address Set-up Time	2		2		
t <sub>AH</sub>	Address Hold Time	1		1		
t <sub>CKS</sub>	CKE Set-up Time	2		2		
t <sub>CKH</sub>	CKE Hold Time	1		1		
t <sub>CMS</sub>	Command Set-up Time	2		2		
t <sub>CMH</sub>	Command Hold Time	1		1		
t <sub>REF</sub>	Refresh Time		64		64	ms
t <sub>RSC</sub>	Mode Register Set Cycle Time	2		2		CLK
t <sub>DPL</sub>	Data in to Precharge	1		1		
t <sub>BDL</sub>	Last Data in to Burst Stop	1		1		
t <sub>DAL</sub>	Data in to Active Command	t <sub>DPL</sub> +t <sub>RP</sub>		t <sub>DPL</sub> +t <sub>RP</sub>		

(CL=CAS Latency)

**MODE REGISTER (ADDRESS INPUT FOR MODE SET)**

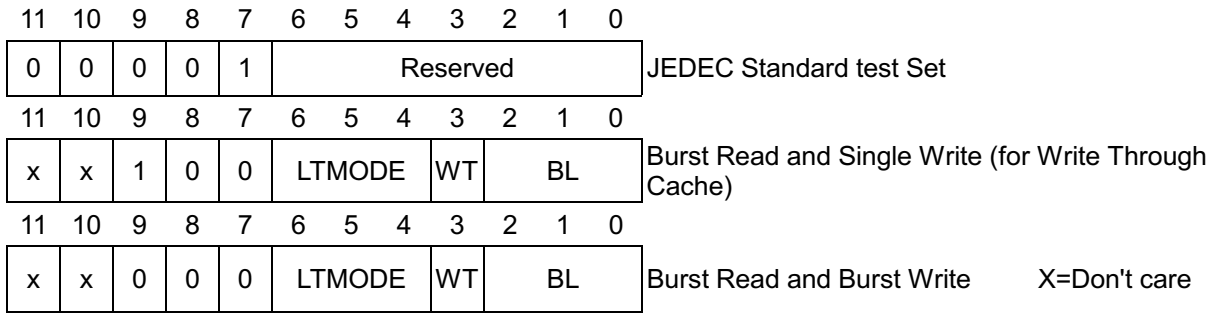

Burst length	Bits2-0	WT=0	WT=1
	000	1	1
	001	2	2
	010	4	4
	011	8	8
	100	R	R
	101	R	R
	111	Full page	R

Wrap type	0	Sequential
	1	Interleave

Latency mode	Bits6-4	/CAS latency
	000	R
	001	R
	010	2
	011	3
	100	R
	101	R
	111	R

Remark R: Reserved



## DC CHARACTERISTICS

Recommended D.C. Operating condition ( $V_{DD} = 3.3V \pm 0.3V$ ,  $T_A = 0$  to  $70^\circ C$ )

DESCRIPTION/TEST CONDITION	SYMBOL	-6		-7		UNIT
		Min.	Max.	Min.	Max.	
Operating Current $t_{RC} \geq t_{RC(min)}$ , Outputs Open Address changed once during $t_{CK(min)}$ . Burst Length = 1 (One Bank Active)	$I_{DD1}$		110		120	mA
Precharge Standby Current in non power-down mode $t_{CK} = t_{CK(min)}$ , $/CS \geq V_{IH(min)}$ , $CKE \geq V_{IH(min)}$ , Input signals are changed once during 30ns.	$I_{DD2N}$		40		50	
Precharge Standby Current in non power-down mode $t_{CK} = \infty$ , $CKE \geq V_{IH(min)}$ , $CLK \leq V_{IL(max)}$ , Input signals are stable	$I_{DD2NS}$		20		30	
Precharge Standby Current in power-down mode $t_{CK} = t_{CK(min)}$ , $CKE \leq V_{IL(max)}$	$I_{DD2P}$		2		3	
Precharge Standby Current in power-down mode $t_{CK} = \infty$ , $CKE \leq V_{IL(max)}$ , $CLK \leq V_{IL(max)}$	$I_{DD2PS}$		2		2.8	
Active Standby Current in non power-down mode $CKE \geq V_{IH(min)}$ , $t_{CK} = t_{CK(min)}$ (Both Bank Active)	$I_{DD3N}$		60		70	
Active Standby Current in power-down mode $CKE \leq V_{IL(max)}$ , $t_{CK} = t_{CK(min)}$ , $/CS \geq V_{IH(min)}$ (Both Bank Active)	$I_{DD3P}$		5		5	
Operating Current (Page Burst, and All Bank activated) $t_{CCD} = t_{CCD(min)}$ , Outputs Open, Multi-bank interleave, gapless data	$I_{DD4}$		120		130	
Refresh Current $t_{RC} \geq t_{RC(min)}$ , ( $t_{REF} = 32ms$ )	$I_{DD5}$		120		130	
Self Refresh Current $CKE \leq 0.2V$	$I_{DD6}$		2		2.5	

PARAMETER	DESCRIPTION	MIN.	MAX.	UNIT
$I_{IL}$	Input Leakage Current ( $0V \leq V_{IN} \leq V_{DD}$ All other pins not under test = 0V)	-5	5	$\mu A$
$I_{OL}$	Output Leakage Current Output disable, ( $0V \leq V_{OUT} \leq V_{DDQ}$ )	-5	5	$\mu A$
$V_{OH}$	LVTTL Output "H" Level Voltage ( $I_{OUT} = -2mA$ )	2.4	-	V
$V_{OL}$	LVTTL Output "L" Level Voltage ( $I_{OUT} = 2mA$ )	-	0.4	V

PARAMETER	CONDITIONS
Reference Level of Output Signals	1.4V/1.4V
Output board	Reference to the Under Output Load (B)
Input Signal Levels	3.0V / 0.0V
Transition Time (Rise and Fall) of Input Signals	1nS
Reference Level of Input Signals	1.4V

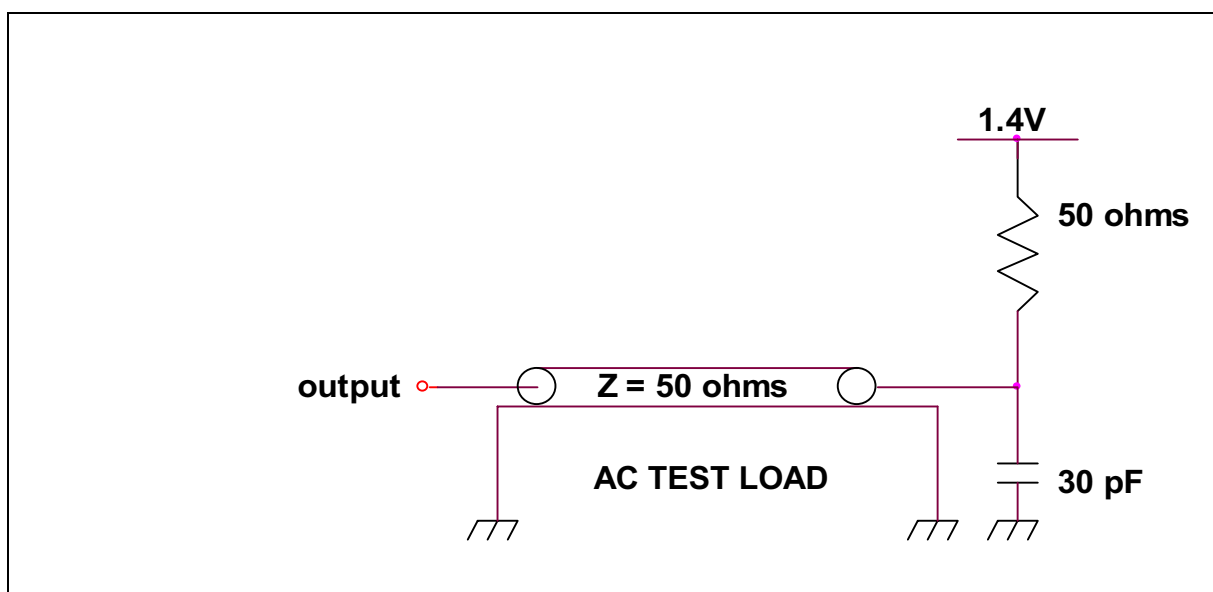

The copyright of the products or specification is owned by Kreton Corp.  
 Kreton Corp. reserves the right to change products or specification without notice.