

Power supply unit for LCD drives

BP5311

The BP5311 is a DC-DC converter unit for supplying power to liquid crystal display (LCD) panels. The unit supplies a positive voltage for LCDs from a logic circuit power supply (+5V)

●Applications

LCD panels in personal computers and word processors

●Features

- 1) High conversion efficiency.
- 2) Built-in protection circuit.
- 3) Built-in ON / OFF switch.
- 4) Compact and light.
- 5) Surface mounting is possible because parts are concentrated on one side.

●Absolute maximum ratings (Ta = 25°C)

Parameter	Symbol	Limits	Unit
Power supply voltage	V_{IN}	7	V
Operating temperature	T_{opr}	0~+60	°C
Storage temperature	T_{stg}	-30~+85	°C

●Block diagram

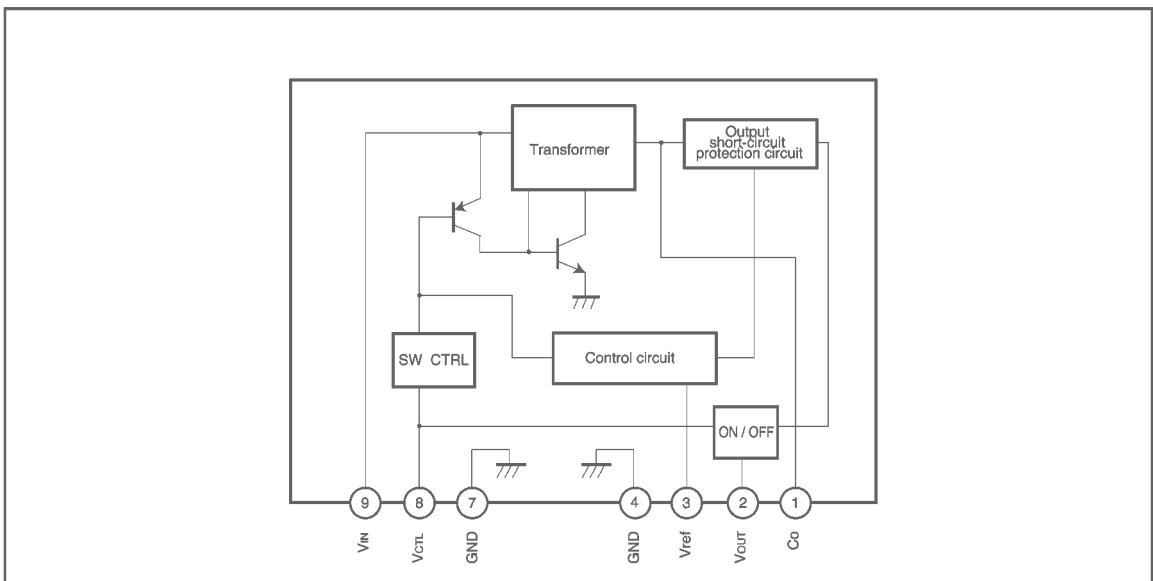

● Pin descriptions

Pin No.	Pin name	Function
1	Co	Output smoothing capacitor connection ; connect a low-impedance capacitor with a recommended capacitance of 47 μ F between this pin and GND
2	V _{OUT}	Output
3	V _{ref}	Output voltage pin for contrast adjustment; output voltage is adjusted by connecting a resistor between pins 2 and 3 or pins 3 and 4
4, 7	GND	Ground
8	V _{CTL}	Output ON/OFF control ; output starts when the pin is HIGH level, and stops when the pin is LOW or OPEN
9	V _{IN}	Input ; connect a low-impedance capacitor with a recommended capacitance of 100 μ F between this pin and GND

● Electrical characteristics

(unless otherwise noted, Ta = 25°C, V_{CTL} = 5V, and R1 and R2 resistors are disconnected)

Parameter	Symbol	Min.	Typ.	Max.	Unit	Conditions
Input voltage	V _{IN}	4.5	5.0	5.5	V	—
Output current	I _{OUT}	—	—	25	mA	—
Output voltage	V _{OUT1}	28.0	29.5	31.0	V	V _{IN} =4.5~5.5V, I _{OUT} =0~25mA
Output voltage when OFF	V _{OUT2}	—	—	0.3	V	V _{IN} =4.5~5.5V, V _{CTL} =0V
Ripple noise voltage	v ₁	—	100	200	mV _{P.P}	V _{IN} =5V, I _{OUT} =20mA *
Efficiency	η	67	77	—	%	V _{IN} =5V, I _{OUT} =20mA
ON/OFF CTL voltage when ON	V _{CTL}	1.5	—	—	V	V _{IN} =5V, V _O >28V
ON/OFF CTL voltage when OFF	V _{CTL}	—	—	0.5	V	V _{IN} =5V, V _O <0.3V (Alternatively, when OPEN)
ON/OFF CTL CTL current	I _{CTL}	—	—	500	μ A	V _{IN} =5V, V _{CTL} =1.5V
Current dissipation when OFF	I _{OFF}	—	—	50	μ A	V _{IN} =5V, V _{CTL} =0V

* Measured with a band width of 20 MHz.

● Measurement circuit and application example

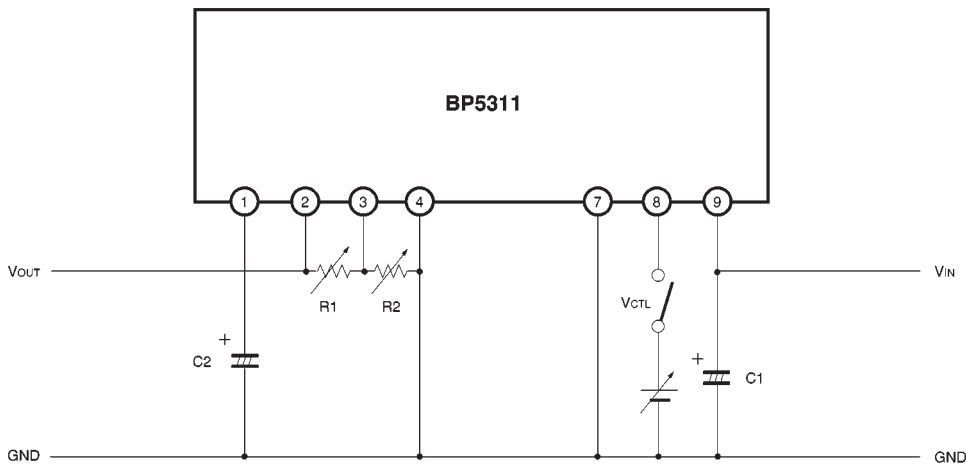

Fig. 1

C1: 100 μ F / 16 V (NICHICON PL-series or equivalent)
 C2: 47 μ F / 35 V (NICHICON PL-series or equivalent)
 R1, 2: Resistors for adjusting output voltage (contrast adjustment)

● Operation notes

- (1) Place I/O external capacitors as near as possible to the connection pins. In particular, make sure to minimize the impedance between the input-side capacitor (C1) and pin 9. A length less than 50 mm is recommended for a copper foil of 1.0 mm wide and 35 μ m thick.
- (2) Avoid frequent switching using the ON/OFF CTL pin (four times per second at the maximum).
- (3) R1 and R2 resistors, which are used for changing the output voltage, are usually not required.

● Electrical characteristic curves

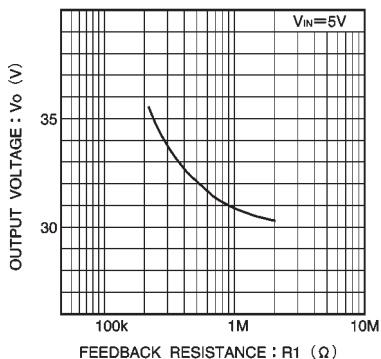

Fig. 2 Output voltage vs. feedback resistance (R1)

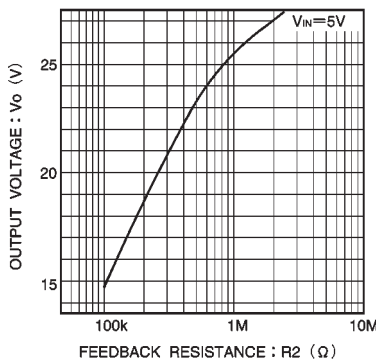

Fig. 3 Ooutput voltage and feedback resistance (R2)

● External dimensions (Units: mm)

