

THIS DOCUMENT AND THE DATA DISCLOSED HEREIN OR HEREWITH IS NOT TO BE REPRODUCED, USED, OR DISCLOSED IN WHOLE OR IN PART TO ANYONE WITHOUT PERMISSION OF VICOR CORP.

REV.	DESCRIPTION	DATE	APPROVED
#1	RELEASED FOR DEVELOPMENT	DPK 2/27/97	SWN
#2	M3X.5 WAS #4-40	DPK 3/3/97	SWN
#3	REVISED DRAWING	JMR 3/6/97	SWN
#4	#4-40 TAP WAS M3X.5	DPK 4/28/97	SWN
#5	REVISED PROFILE AND NO. OF FINS	DPK 11/19/97	SWN
#6	ADDED +.010 TO TO DIM	DPK 12/8/97	SWN
#7	.49 WAS .490: REMOVED P/N STAMPING	DPK 8/24/98	SWN
#8	2.22 WAS 2.220	DPK 9/2/98	SWN
#9	.40 WAS .400: ADDED 'U' TO .100 & .190	DPK 9/2/98	SWN
#A	ADDED NOTE 4, CRITICAL CHA. 'O'	AK 10/6/99	SWN

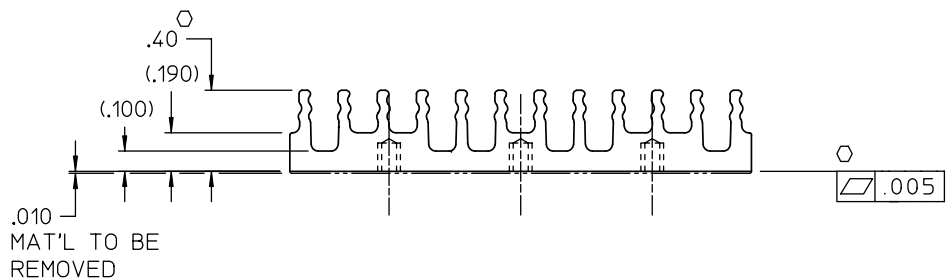
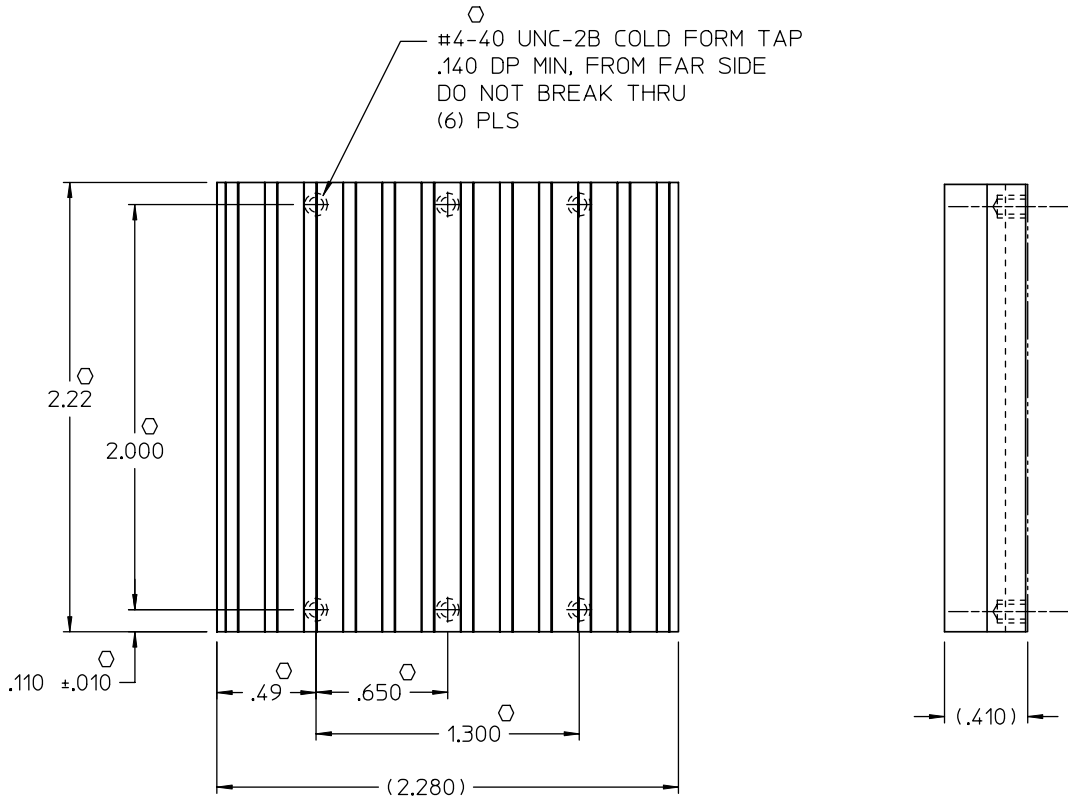

- NOTES
1. MAKE FROM VICOR EXTRUSION P/N 16296.
  2. REMOVE ALL BURRS AND SHARP EDGES.
  3. FINISH. CLEAR CHROMATE.
  4. "O" DENOTES CRITICAL CHARACTERISTICS FOR LOT INSPECTION.

DRAWN BY <b>D.P. KELLY</b>		DATE <b>2/97</b>			
<small>UNLESS OTHERWISE SPECIFIED DIMENSIONS ARE IN INCHES- TOLERANCES ARE: FRACTIONS DECIMALS ANGLES</small> *1/64 .XX+ .01 *° .XXX+ .005					
THIRD ANGLE PROJECTION 		SIZE <b>C</b>	FSCM NO. <b>67131</b>	DWG NO. <b>16297</b>	REV <b>#A</b>
DO NOT SCALE DRAWING			SCALE 2-1	SHEET 1 OF 1	