



YSS912

AC3D2

Dolby Digital (AC-3) / Pro Logic / DTS decoder + Sub DSP

■ INTRODUCTION

The YSS912 is one chip LSI consisting two built-in DSP's ; Dolby Digital (AC-3) / Pro Logic / DTS decoder (Main DSP) and a sound processing DSP (Sub DSP). Sub DSP is capable of realizing various sound fields, such as virtual surround, by down-loading the program and coefficient. Sub DSP is compatible with YSS902, the Sub DSP programs developed for YSS902 are also applicable to YSS912.

■ FEATURERS

- Pin compatible with YSS902 (AC3D).
- Dolby Digital (AC-3) / Pro Logic and DTS decode.
- 24 bit DSP. (Group-A Dolby Digital decoder)
- No external memory is required (Memory for center and surround channel delay is included) when DTS decoding as well as AC-3 / Pro Logic.
- Possible to decode multi-language encoded data. (possible to decode based on data-stream-number)
- AC-3 karaoke mode.
- Original compression mode as well as four compression modes recommended by Dolby. (when AC-3 decoding)
- Included de-emphasis filter.
- Pro Logic decoding for Dolby digital 2 channels decoded signal as well as ordinary PCM.
- High performance 25 MIPS programmable DSP suitable for a variety of sound field processing such as original surround , filtering, virtual surround etc.
- Up to 1.36 second delay time is capable when used with an external 1Mbit SRAM. (at fs= 48 kHz)
- Reads Dolby Digital (AC-3)/DTS decode information through the microprocessor interface.
- Provide total sixteen I/O ports.
- Possible to connect most of SPDIF receivers, A/D and D/A converters, by setting I/O data interface format.
- Has a built-in PLL oscillation circuit to generates its own operating clock.
- Internal operating clock is 30 MHz.
- Supply Voltage: 3.3v for core logic. 5v for I/Os.
- Power saving mode.
- Si-gate CMOS process.
- 100 QFP.(YSS912-F)

Note: "AC-3" and "Pro Logic" are registered trademarks of Dolby Laboratories Licensing Corporation.

"DTS" is a registered trademark of DTS, Inc.

Use of this LSI must be licensed by both Dolby Laboratories Licensing Corporation and DTS, Inc.

YAMAHA CORPORATION

■ 9945524 0003972 744 ■

YSS912CATALOG
CATALOG No.:LSI-4SS912A2
1998. 10

■ PIN CONFIGURATION

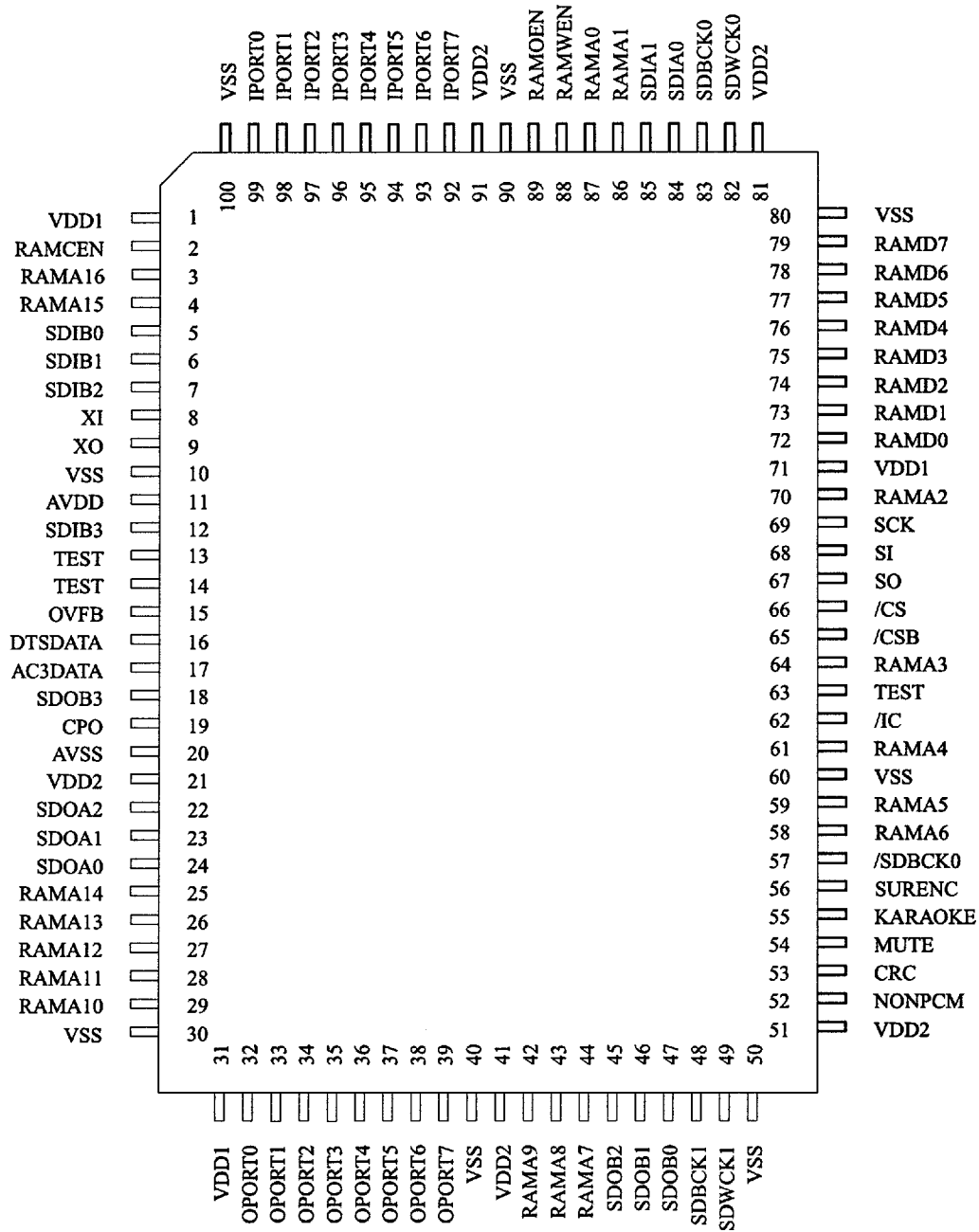

< 100QFP TOP VIEW >

■ PIN FUNCTION

No.	Name	I/O	FUNCTION
1	VDD1	-	+5V power supply (for I/Os)
2	RAMCEN	O	External SRAM interface /CE
3	RAMA16	O	External SRAM interface address 16
4	RAMA15	O	External SRAM interface address 15
5	SDIB0	I+	PCM input 0 to Sub DSP
6	SDIB1	I+	PCM input 1 to Sub DSP
7	SDIB2	I+	PCM input 2 to Sub DSP
8	XI	I	Crystal oscillator connection (12.288 MHz)
9	XO	O	Crystal oscillator connection
10	VSS	-	Ground
11	AVDD	-	+3.3 V power supply (for PLL circuit)
12	SDIB3	I+	PCM input 3 to Sub DSP
13	TEST		Test terminal (to be open in normal use)
14	TEST		Test terminal (to be open in normal use)
15	OVFB	O	Detection of overflow at Sub DSP
16	DTSDATA	O	Detection of DTS data
17	AC3DATA	O	Detection of AC-3 data
18	SDOB3	O	PCM output from Sub DSP
19	CPO	A	Output terminal for PLL, to be connected to ground through the external analog filter circuit
20	AVSS	-	Ground (for PLL circuit)
21	VDD2	-	+3.3 V power supply (for core logic)
22	SDOA2	O	PCM output from Main DSP (C, LFE)
23	SDOA1	O	PCM output from Main DSP (LS, RS)
24	SDOA0	O	PCM output from Main DSP (L, R)
25	RAMA14	O	External SRAM interface address 14
26	RAMA13	O	External SRAM interface address 13
27	RAMA12	O	External SRAM interface address 12
28	RAMA11	O	External SRAM interface address 11
29	RAMA10	O	External SRAM interface address 10
30	VSS	-	Ground
31	VDD1	-	+5V power supply (for I/Os)
32	OPORT0	O	Output port for general purpose
33	OPORT1	O	Output port for general purpose
34	OPORT2	O	Output port for general purpose
35	OPORT3	O	Output port for general purpose
36	OPORT4	O	Output port for general purpose
37	OPORT5	O	Output port for general purpose
38	OPORT6	O	Output port for general purpose
39	OPORT7	O	Output port for general purpose
40	VSS	-	Ground
41	VDD2	-	+3.3 V power supply (for core logic)
42	RAMA9	O	External SRAM interface address 9
43	RAMA8	O	External SRAM interface address 8
44	RAMA7	O	External SRAM interface address 7
45	SDOB2	O	PCM output from Sub DSP
46	SDOB1	O	PCM output from Sub DSP
47	SDOB0	O	PCM output from Sub DSP
48	SDBCK1	I+	Bit clock input for SDOA, SDIB, SDOB
49	SDWCK1	I+	Word clock input for SDOA, SDIB, SDOB
50	VSS	-	Ground
51	VDD2	-	+3.3 V power supply (for core logic)
52	NONPCM	O	Detection of non-PCM data
53	CRC	O	Detection of AC-3 CRC error
54	MUTE	O	Detection of auto mute
55	KARAOKE	O	Detection of AC-3 karaoke data

No.	Name	I/O	FUNCTION
56	SURENC	O	Detection of AC-3 2/0 mode Dolby surround encoded input
57	/SDBCK0	O	Inverted SDBCK0 clock output (refer to Block diagram)
58	RAMA6	O	External SRAM interface address 6
59	RAMA5	O	External SRAM interface address 5
60	VSS	-	Ground
61	RAMA4	O	External SRAM interface address 4
62	/IC	Is	Initial clear
63	TEST		Test terminal (to be open in normal use)
64	RAMA3	O	External SRAM interface address 3
65	/CSB	Is+	Sub DSP Chip select
66	/CS	Is	Microprocessor interface Chip select input
67	SO	Ot	Microprocessor interface Serial data output
68	SI	Is	Microprocessor interface / Sub DSP Serial data input
69	SCK	Is	Microprocessor interface / Sub DSP clock input
70	RAMA2	O	External SRAM interface address 2
71	VDD1	-	+5V power supply (for I/Os)
72	RAMD0	I+/ O	External SRAM interface data (STREAM0 output when External SRAM is not in use)
73	RAMD1	I+/ O	External SRAM interface data (STREAM1 output when External SRAM is not in use)
74	RAMD2	I+/ O	External SRAM interface data (STREAM2 output when External SRAM is not in use)
75	RAMD3	I+/ O	External SRAM interface data (STREAM3 output when External SRAM is not in use)
76	RAMD4	I+/ O	External SRAM interface data (STREAM4 output when External SRAM is not in use)
77	RAMD5	I+/ O	External SRAM interface data (STREAM5 output when External SRAM is not in use)
78	RAMD6	I+/ O	External SRAM interface data (STREAM6 output when External SRAM is not in use)
79	RAMD7	I+/ O	External SRAM interface data (STREAM7 output when External SRAM is not in use)
80	VSS	-	Ground
81	VDD2	-	+3.3 V power supply (for core logic)
82	SDWCK0	I	Word clock input for SDIA, SDOA, SDIB, SDOB
83	SDBCK0	I	Bit clock input for SDIA, SDOA, SDIB, SDOB
84	SDIA0	I	AC-3 bitstream (or PCM) data input for Main DSP
85	SDIA1	I	AC-3 bitstream (or PCM) data input for Main DSP
86	RAMA1	O	External SRAM interface address 1
87	RAMA0	O	External SRAM interface address 0
88	RAMWEN	O	External SRAM interface /WE
89	RAMOEN	O	External SRAM interface /OE
90	VSS	-	Ground
91	VDD2	-	+3.3 V power supply (for core logic)
92	IPORT7	I+	Input port for general purpose
93	IPORT6	I+	Input port for general purpose
94	IPORT5	I+	Input port for general purpose
95	IPORT4	I+	Input port for general purpose
96	IPORT3	I+	Input port for general purpose
97	IPORT2	I+	Input port for general purpose
98	IPORT1	I+	Input port for general purpose
99	IPORT0	I+	Input port for general purpose
100	VSS	-	Ground

NOTE) Is: Schmidt trigger input terminal
I+: Input terminal with a pull-up resistor
O: Digital output terminal
Ot: Tri-state digital output terminal
A: Analog terminal

■ BLOCK DIAGRAM

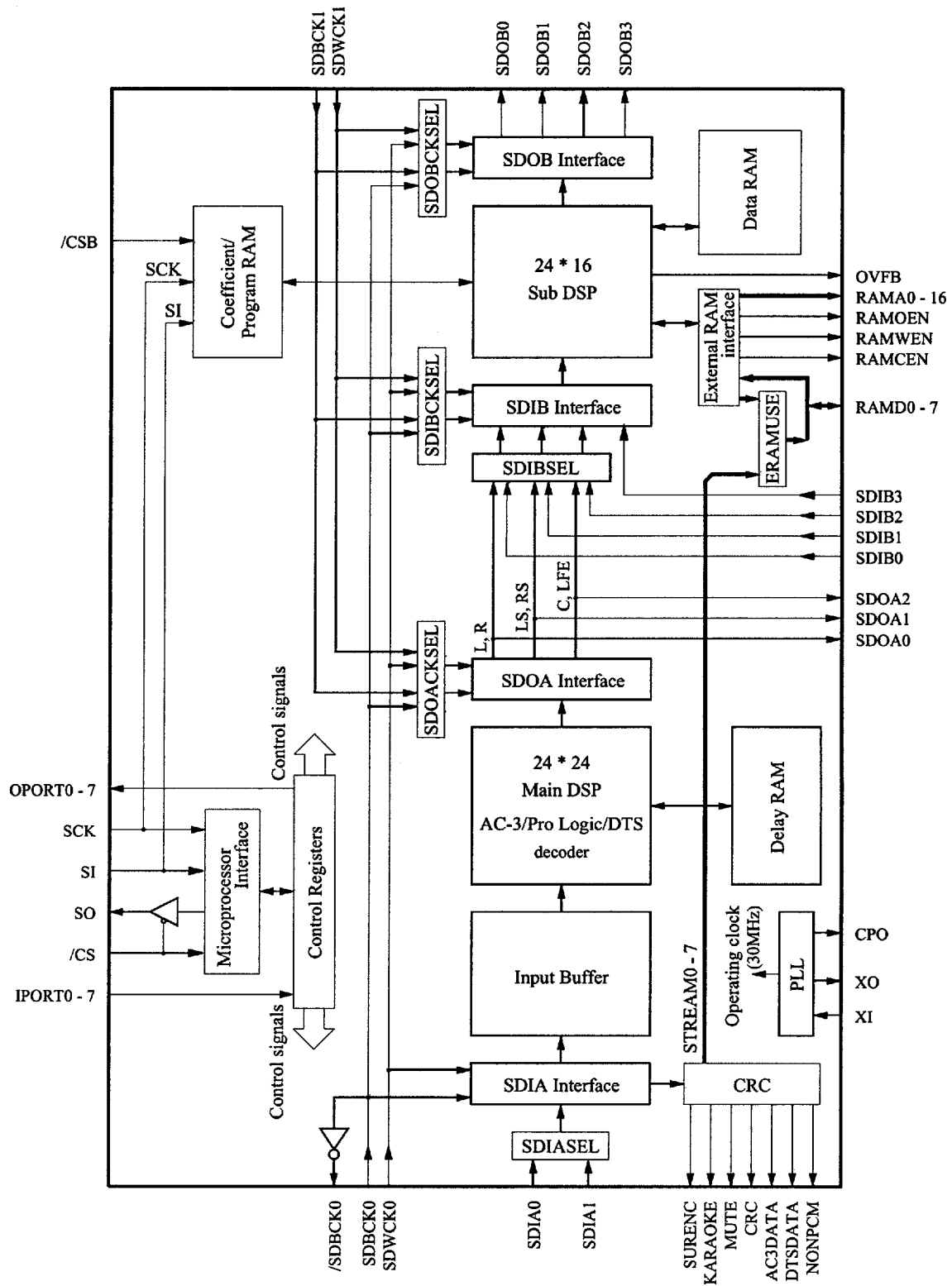

■ FUNCTION DESCRIPTION

The YSS912 consist of Main DSP section where AC-3/Pro Logic/DTS decoding is executed and Sub DSP section where various sound field effects are added. Please refer to "BLOCK DIAGRAM" section.

Sub DSP is a 8 ch input / 8 ch output programmable DSP exclusively for the sound field processing. It can apply such effects as virtual surround, echo and equalizing. In addition, with an SRAM up to 1Mbit connected, it can produce reverberation for one second or longer. By using this function, it is possible to simulate various sound fields such as a hall or a church.

* If adopting some technology owned by another company is desired for use in Sub DSP section, note that a separate contract may be required between the owner of that technology and the user with respect to adoption of the technology.

1. Clocks XI, XO, CPO

The crystal oscillation circuit is formed by using XI and XO terminals.

Connect a crystal of 12.288 MHz between XI and XO terminals.

Connect an external analog filter between CPO terminal and Ground.

2. Data Interface SDIA0, SDIA1, SDOA0-2, SDIB0-3, SDOB0-3, SDWCK0, SDBCK0, SDWCK1, SDBCK1, /SDBCK0

Main DSP section

AC-3/PCM/DTS data should be fed from SDIA0 or SDIA1 terminal. These signals are processed by AC-3/Pro Logic/DTS decoding procedure in Main DSP section and then transmitted to Sub DSP section as well as outputted through SDOA0-2 terminals.

Sub DSP section

In Sub DSP section, various types of processing can be applied to the PCM data decoded in Main DSP section or inputted through SDIB0 - 3 terminals. Then, processed signals are outputted from each of SDOB0-3 terminals.

Following parameters can be selected by changing the control register setting.

- Selection of Main DSP input signal (SDIA0, SDIA1)
- Selection of Sub DSP input signal (Main DSP output, SDIB0-3 input)
- Polarity of bit clock and word clock
- Format and bit count of input/output data

For more information on the format of the input/output data, please refer to "Serial Data Interface" section.

3. Microprocessor Interface /CS, /CSB, SCK, SI, SO

The control registers can be read/written via the serial microprocessor interface by using /CS, SCK, SI, and SO terminals.

Please refer to the following format diagram for the details of read/write timing.

Format diagram for read/write timing

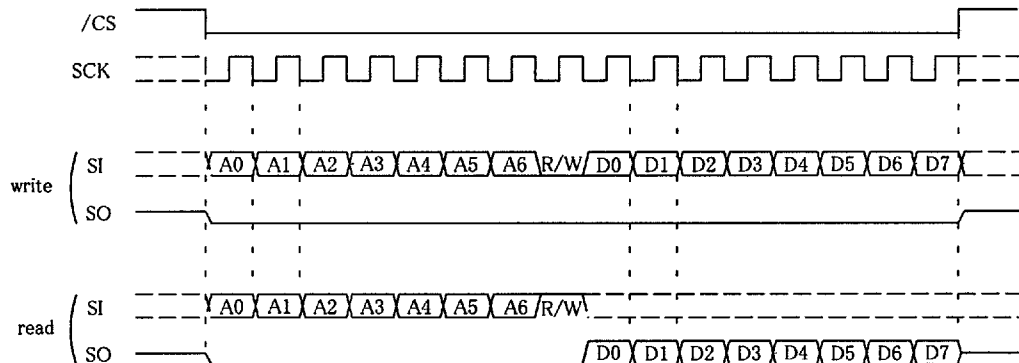

When /CS=1, the SO output becomes high-impedance.

* Be sure to set /CSB to "1" when making an access to the control register.

The sound field processing program used for Sub DSP is down-loaded by using the /CSB, SCK, and SI terminals. Please refer to Application manual for the details of Sub DSP.

4. External Interface RAMA0-16, RAMD0-7, RAMCEN, RAMOEN, RAMWEN
An external SRAM can be connected to Sub DSP.

5. General purpose I/O ports OPORT0-7, IPORT0-7
OPORT0-7 terminals are output ports for general purpose. Data written on the register (address 0x04) are outputted from these terminals.
IPORT0-7 terminals are input ports for general purpose. Data inputted to these terminals can be read from the register (address 0x05).

6. Initial clear /IC
This LSI requires initial clear when turning on the power.

7. LSI test terminals TEST
Leave the test terminals open in normal use.

■ CONTROL REGISTER

The decoding system is controlled by reading and writing the control registers through microprocessor interface (/CS, SCK, SI and SO).

Note : All bits are set to "0" by initial clear (/IC=0) except bit 4 of PLL/DSN register (0x00).

address	Name	bit 7	bit 6	bit 5	bit 4	bit 3	bit 2	bit 1	bit 0
0x00	PLL/DSN Register	PLLUSE	(not used)			DSNIGN	DSN2 - 0		
0x01	Mute Register	LMUTEN	CMUTEN	RMUTEN	RSMUTEN	LSMUTEN	LFEMUTEN	DSPMUTEN	AMOFF
0x02	SDIA Register	SDIASEL	PDOWN	SDIAFMT1 - 0		SDIABIT1 - 0		SDIAWP	SDIABP
0x03	SDOA Register	SDOACKSEL		SDOAFMT1 - 0		SDOABIT1 - 0		SDOAWP	SDOABP
0x04	OPORT Register	OPORT7 - 0							
0x05	IPORT Register	IPORT7 - 0 (Read only)							
0x09	Noise Level Register	NOISELEV7 - 0							
0x0A	Center Delay Register							CDELAY2 - 0	
0x0B	Surround Delay Register							SRDELAY3 - 0	
0x0C	Noise Register	NOISE	PN/WN	IMPULSE					
0x0D	FS Register								FS1 - 0
0x0E	L Volume Register	LVOL7 - 0							
0x0F	C Volume Register	CVOL7 - 0							
0x10	R Volume Register	RVOL7 - 0							
0x11	LS Volume Register	LSVOL7 - 0							
0x12	RS Volume Register	RSVOL7 - 0							
0x13	LFE Volume Register	LFEVOL7 - 0							
0x14	Compression Register	EMPON	AIBON	VOLON	DITHOFF	P11OFF	DIALOFF	COMPMOD1 - 0	
0x15	HDYNRNG Register	HDYNRNG7 - 0							
0x16	LDYNRNG Register	LDYNRNG7 - 0							
0x17	Mode Register	PCM	PLDECON	PLSRMOD	DUALMOD1 - 0		OUTMOD2 - 0		
0x30	COEF0-H Register	COEF0-15 - 8							
0x31	COEF0-L Register	COEF0-7 - 0							
0x32	COEF1-H Register	COEF1-15 - 8							
0x33	COEF1-L Register	COEF1-7 - 0							
0x34	SDIB Register	SDIBCKSEL	SDIBSEL	SDIBFMT1 - 0		SDIBBIT1 - 0		SDIBWP	SDIBBP
0x35	SDOB Register	SDOBCKSEL	SDBUSE	SDOBFMT1 - 0		SDOBBIT1 - 0		SDOBWP	SDOBBP
0x36	ERAM Register	ERAMUSE	MPCNT5 - 0						

Note : Do not write "1" into the cross-hatched bits because they are used for testing the LSI.

The following registers of address 0x18 to 0x2F are read-only (write disabled).

The contents of the registers of address 0x18 to 0x2A vary depending on input signal, AC-3 bitstream, DTS bitstream or PCM, as described below.

1) When input signal is AC-3 bitstream

address	Name	bit 7	bit 6	bit 5	bit 4	bit 3	bit 2	bit 1	bit 0
0x18	Bitstream Register 0	fscod		frmsizecod					
0x19	Bitstream Register 1	bsid				bsmod			
0x1A	Bitstream Register 2	acmod			cmixlev		surmixlev		lfeon
0x1B	Bitstream Register 3	dsurmod		copyrightb	origbs	0	0	0	0
0x1C	Bitstream Register 4	0	0	0	dialnorm				
0x1D	Bitstream Register 5	0	0	0	dialnorm2				
0x1E	Bitstream Register 6	audprodie	mixlevel				roomtyp		
0x1F	Bitstream Register 7	audprodi2e	mixlevel2				roomtyp2		
0x20	Bitstream Register 8	timecod1e	0	timecod1					
0x21	Bitstream Register 9	timecod1							
0x22	Bitstream Register 10	timecod2e	0	timecod2					
0x23	Bitstream Register 11	timecod2							
0x24	Bitstream Register 12	langcode	langcod2e	compre	compr2e	0	0	0	0
0x25	Bitstream Register 13	langcod							
0x26	Bitstream Register 14	langcod2							
0x27	Bitstream Register 15	compr							
0x28	Bitstream Register 16	compr2							
0x29	Bitstream Register 17	dynrng							
0x2A	Bitstream Register 18	dynrng2							

2) When input signal is DTS bitstream

address	Name	bit 7	bit 6	bit 5	bit 4	bit 3	bit 2	bit 1	bit 0	
0x18	Bitstream Register 0	fscod		undefined	RATE					
0x19	Bitstream Register 1	undefined								
0x1A	Bitstream Register 2	AMODE							undefined	lfeon
0x1B	Bitstream Register 3	undefined					PCMR			

The contents of registers of address 0x1C to 0x2A are undefined.

3) When input signal is PCM

The contents of registers of address 0x18 to 0x2A are undefined.

The registers of address 0x2B, 0x2C are not used.

From the registers of address 0x2D to 0x2F, the following data can be read.

address	Name	bit 7	bit 6	bit 5	bit 4	bit 3	bit 2	bit 1	bit 0
0x2D	Pc Register	undefined			Pc4 - 0				
0x2E	Data Stream Register	STREAM7	STREAM6	STREAM5	STREAM4	STREAM3	STREAM2	STREAM1	STREAM0
0x2F	Status Register	DTSDATA	AC3DATA	2/0MODE	SURENC	KARAOKE	MUTE	CRC	NONPCM

Address 0x06 to 0x08 and 0x37 to 0x7F are assigned for TEST. Never access to these registers.

Please refer to Application manual for details of Control register.

■ SERIAL DATA INTERFACE

Data timing of the serial data interface is as follows.

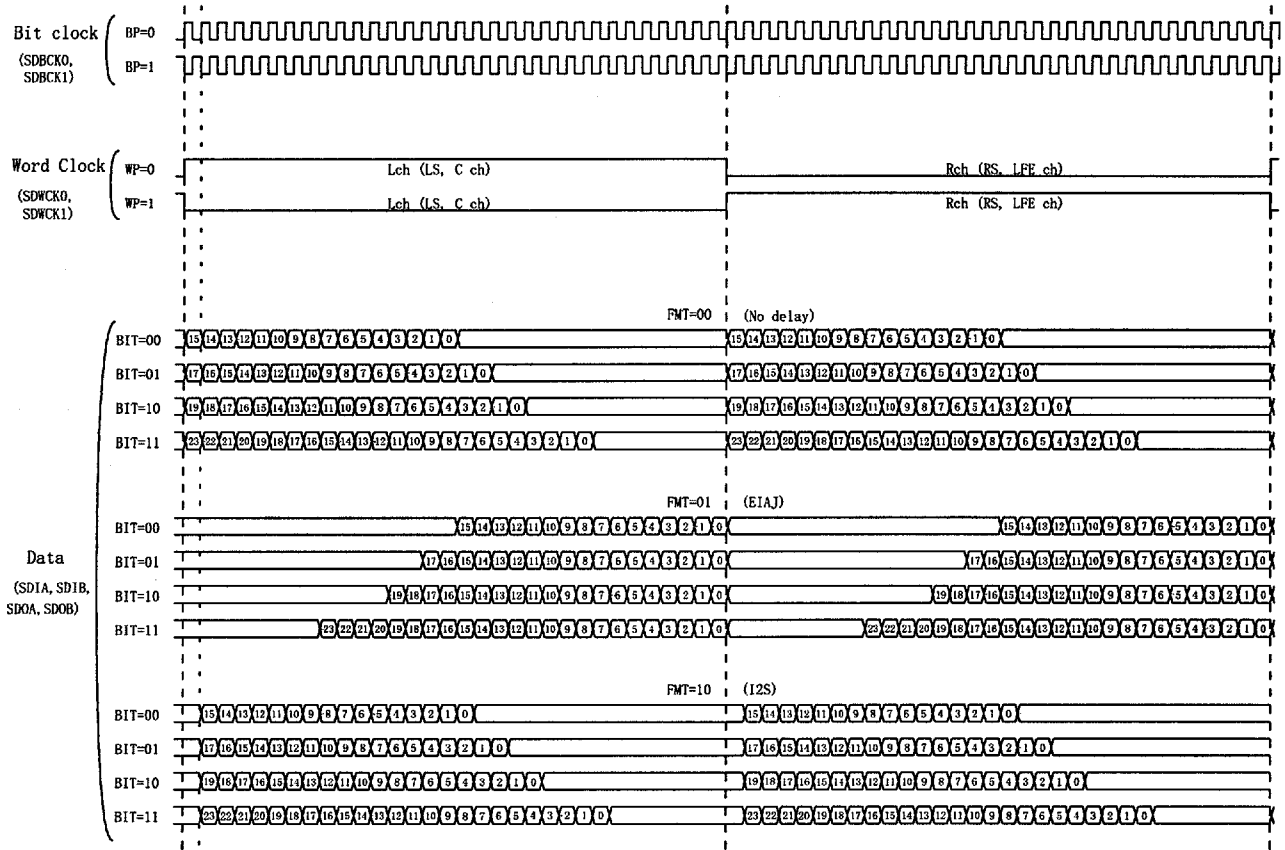

Please refer to Application manual for details of SDIA, SDOA, SDIB, and SDOB registers.

■ ELECTRICAL CHARACTERISTICS

1. Absolute Maximum Ratings

Parameter	Symbol	Min.	Max.	Unit
Power Supply Voltage	VDD1	V _{SS} -0.5	V _{SS} +7.0	V
	VDD2, AVDD	V _{SS} -0.5	V _{SS} +4.6	V
Input Voltage	V _I	V _{SS} -0.5	VDD1+0.5	V
Storage Temperature	T _{stg}	-50	125	°C

2. Recommended Operating Conditions

Parameter	Symbol	Min.	Typ.	Max.	Unit
Power Supply Voltage	VDD1	4.75	5.0	5.25	V
	VDD2, AVDD	3.0	3.3	3.6	V
Operating Temperature	T _{op}	0	25	70	°C

3. DC Characteristics (Condition: Under Recommended Operating Conditions)

Parameter	Symbol	Condition	Min.	Typ.	Max.	Unit
Input Voltage H Level (1)	V _{IH1}	*1	0.7VDD1			V
Input Voltage H Level (2)	V _{IH2}	*2	2.2			V
Input Voltage L Level (1)	V _{IL1}	*1			0.2VDD1	V
Input Voltage L Level (2)	V _{IL2}	*2			0.8	V
Output Voltage H Level	V _{OH}	I _{OH} = -80 μA	VDD1-1.0			V
Output Voltage L Level	V _{OL}	I _{OL} = 1.6 mA			0.4	V
Input Leakage Current	I _{LI}	Terminal without a pull-up resistor	-10		10	μA
Pull-up Resistor	R _U		25		100	kΩ
Power Consumption	P _D			400	550	mW

*1 Applicable to XI and /IC input terminals.

*2 Applicable to input terminals except XI and /IC terminals.

4. XI and /IC

Parameter	Symbol	Conditions	Min	Typ	Max	Unit
XI clock frequency	X _{in}			12.288		MHz
XI clock duty	X _{duty}		40	50	60	%
/IC pulse width	t _{icw}	Power voltage to be stabilized	500			ns

EXTERNAL DIMENSIONS

C-PK100FP-1

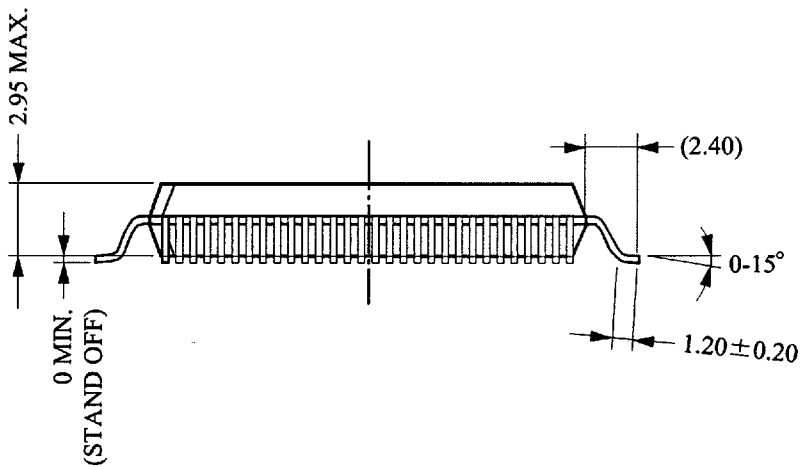
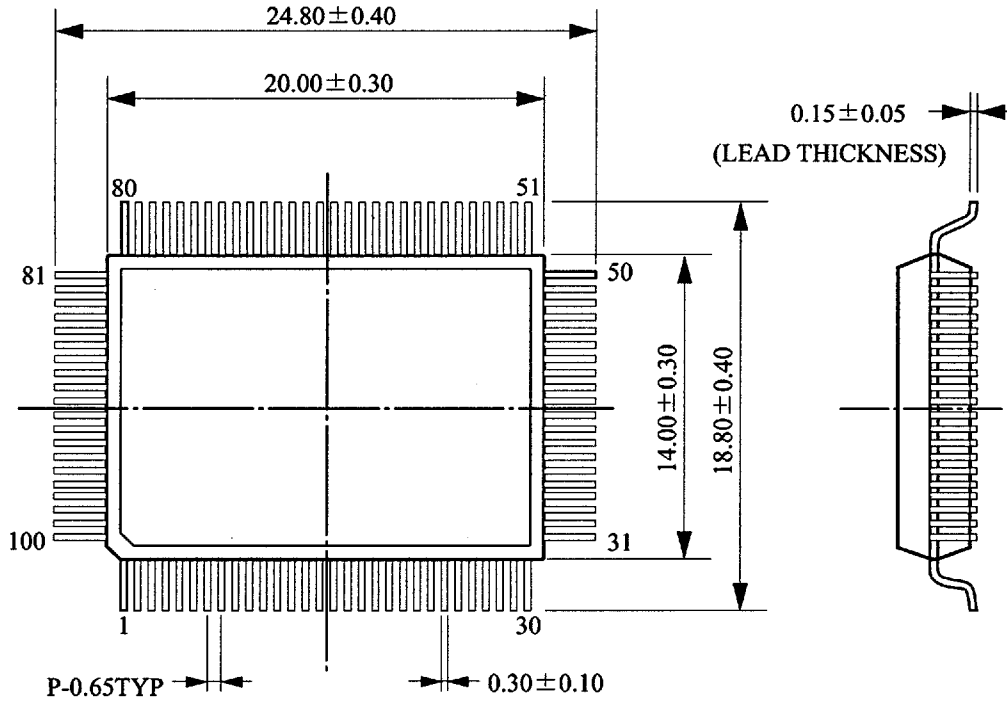

The figure in the parenthesis () should be used as a reference.
 Plastic body dimensions do not include burr of resin.
 UNIT: mm