

IM5603/IM5623 Electrically Programmable 1024 Bit Bipolar Read Only Memory

FEATURES

- Uses Patented AIM Programming Element for
 - Superior Reliability
 - High Programming Yield
 - Fast Programming Speed < 1 sec
 - TTL Processing Compatibility
- Low Power Consumption 439 μ W/bit
- Operating Speed
 - Address to Output — 60nS
 - Chip Enable to Output — 35nS
- Large Output Drive — 16mA @ 0.45V
- TTL Compatible Inputs & Outputs
- Two Output Designs
 - 5603 Open Collector
 - 5623 Active Pull-up
- Chip Enables Facilitate Memory Expansion and Use in Bus Organized Systems

APPLICATIONS

- Code Conversion
- Logic Implementation
- Microprogramming
- Look-up Tables
- Control of Sequential Circuits
- Character Generation

GENERAL DESCRIPTION

The Intersil IM5603 and IM5623 are high speed, electrically programmable, fully decoded, bipolar 1024 bit read only memories organized as 256 words by 4 bits. On-chip address decoding, chip enable inputs and uncommitted collector or three-state outputs provide for simplified memory expansion and use in bus organized systems.

Unprogrammed AIM elements are sensed as ZERO's or low logic levels at the outputs. Programming with a commercially available programmer irreversibly converts selected elements in the array so that they are sensed as ONE's or high logic levels.

The following companies make programmers approved by Intersil:

1. Data I/O Corp., P.O. Box 1603, Bellevue, Wash. 98009
2. PRO-LOG Corp., 2411 Garden Rd., Monterey, CA 93940

Detailed programming specifications for all Intersil PROMs are presented in the Intersil BIPOLAR PROM PROGRAMMING SPECIFICATION Data Sheet.

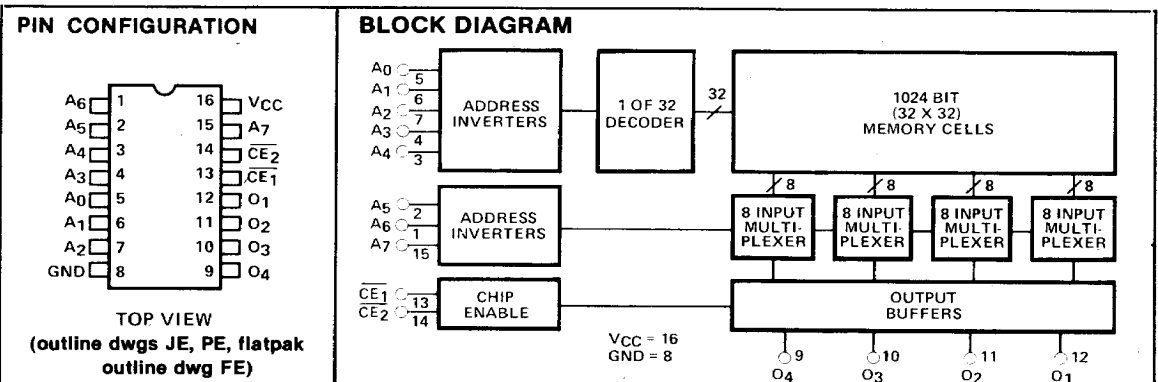

8

ORDERING INFORMATION

| PART NUMBER | PACKAGE | TEMPERATURE RANGE | ORDER NUMBER |
|-------------|--------------------|---|-------------------------|
| IM5603 | 16 Pin Flatpack | 0°C to +75°C Commercial -55°C to +125°C Military | IM5603CFE IM5603MFE* |
| | 16 Pin Plastic DIP | 0°C to +75°C | IM5603CPE |
| | 16 Pin Cerdip DIP | 0°C to +75°C Commercial -55°C to +125°C Military | IM5603CJE IM5603MJE* |
| IM5623 | 16 Pin Flatpack | 0°C to +75°C Commercial -55°C to +125°C Military | IM5623CFE IM5623MFE* |
| | 16 Pin Plastic DIP | 0°C to +75°C | IM5623CPE |
| | 16 Pin Cerdip DIP | 0°C to +75°C Commercial -55°C to +125°C Military | IM5623CJE IM5623MJE* |

* If 883B processing is desired add /883B to order number.

TRUTH TABLE

| ADDRESS INPUTS A ₀ -A ₇ | CHIP ENABLE INPUTS | | ANY OUTPUT O ₁ -O ₄ |
|--|--------------------|-----------------|---|
| | CE ₁ | CE ₂ | |
| Any one of 256 possible addresses | L | L | H-if the bit uniquely associated with this output and address has been electrically programmed. L - if it has not been programmed. |
| Any one of 256 possible addresses | H X | X H | All outputs are forced to a high impedance state regardless of address. |

X = Don't Care

Per Bert Rodero, these IM5603 are all "A" versions

ABSOLUTE MAXIMUM RATINGS

| | |
|---|---------------------------|
| Supply Voltage | +7.0V |
| Input Voltage Applied | -1.5V to 5.5V |
| Output Voltage Applied | -0.5V to +V _{CC} |
| Output Voltage Applied (Programming Only) | 28V |
| Current Into Output (Programming Only) | 210 mA |
| Storage Temperature | -65° C to +150° C |
| Operating Temperature Range* | |
| (IM5603C and IM5623C) | 0° C to +75° C |
| (IM5603M and IM5623M) | -55° C to +125° C |

*Operating temperature is defined as ambient temperature for the DIP and case temperature for flatpack. Case temperature is measured directly below the die.

DC CHARACTERISTICS

| SYMBOL | CHARACTERISTICS | LIMITS V _{CC} = 5.0V ±5% T = 0° C to +75° C | | | LIMITS V _{CC} = 5.0V ±10% T = -55° C to +125° C | | | UNITS | CONDITIONS |
|-------------------------------|-----------------------------------|--|----------------------------|------|--|-------|------|------------------------|---|
| | | MIN | TYP | MAX | MIN | TYP | MAX | | |
| | | I _{FA} | Address Input Load Current | | 0.63 | -1.0 | | | |
| I _{FE} | Chip Enable Input Load Current | | -0.63 | -1.0 | | -0.63 | -1.0 | V _{CE} = 0.4V | |
| I _{RA} | Address Input Leakage Current | | 5 | 40 | | 5 | 60 | μA | V _A = 4.5V |
| I _{RE} | Chip Enable Input Leakage Current | | 5 | 40 | | 5 | 60 | | V _{CE} = 4.5V |
| V _{OL} | Output Low Voltage | | 0.3 | 0.45 | | 0.3 | 0.45 | V | I _{OL} = 16 mA, V _{CE1} = V _{CE2} = 0.4V '0' bit is addressed. |
| V _{IL} | Input Low Voltage | | | 0.8 | | | 0.8 | | |
| V _{IH} | Input High Voltage | 2.0 | | | 2.0 | | | | |
| V _C | Input Clamp Voltage | | -0.9 | -1.5 | | -0.9 | -1.5 | | I _{IN} = -10 mA |
| BV _{IN} | Input Breakdown Voltage | 5.5 | 6.5 | | 5.5 | 6.5 | | | I _{IN} = 1.0 mA |
| I _{CC} | Power Supply Current | | 90 | 130 | | 90 | 130 | mA | Inputs Either Open or at Ground |
| I ₀ (High R State) | Output Leakage Current | | <1 | 40 | | <1 | 100 | | μA |
| I ₀ (High R State) | Output Leakage Current | | <-1 | -40 | | <-1 | -100 | pF | |
| C _{IN} | Input Capacitance | | 5 | | | 5 | | | V ₀ = 2.0V, V _{CC} = 0V |
| C _{OUT} | Output Capacitance | | 7 | | | 7 | | | |

8

The following are guaranteed characteristics of the output high level state when the chip is enabled ($\overline{CE1}$ and $\overline{CE2} = 0.4V$) and a programmed bit is addressed. These characteristics cannot be tested prior to programming but are guaranteed by design.

| | | | | | | | | | |
|--------------------------|------------------------------|------|------|------|------|------|------|----|--|
| I _{OLK} | Output Leakage Current | | <1 | 100 | | <1 | 100 | μA | V ₀ = 5.5V |
| V _{OH} (IM5603) | Output High Voltage | 2.4 | 3.3 | | 2.4 | 3.3 | | V | I _{OH} = -0.4 mA |
| V _{OH} (IM5623) | Output High Voltage | 2.4 | 3.2 | | 2.4 | 3.2 | | | I _{OH} = -2.4 mA (IM5623C) I _{OH} = -1.0 mA (IM5623M) |
| I _{SC} (IM5603) | Output Short Circuit Current | -1.0 | -3.0 | -6.0 | -1.0 | -3.0 | -6.0 | mA | V ₀ = 0V |
| I _{SC} (IM5623) | Output Short Circuit Current | -15 | -30 | -60 | -15 | -30 | -60 | | V ₀ = 0V |

NOTE: Typical characteristics are for V_{CC} = 5.0V T_A = 25° C.

SWITCHING CHARACTERISTICS

| SYMBOL | CHARACTERISTICS | LIMITS $V_{CC} = 5.0V$ $T_A = 25^\circ C$ | | LIMITS $V_{CC} = 5.0V \pm 5\%$ $T_A = 0^\circ C \text{ to } +75^\circ C$ | | LIMITS $V_{CC} = 5.0V \pm 10\%$ $T_A = -55^\circ C \text{ to } +125^\circ C$ | | UNITS |
|-----------|--|---|-----|--|-----|--|-----|-------|
| | | MIN | MAX | MIN | MAX | MIN | MAX | |
| t_{aa} | Access Time (Via Address Inputs) (See Figure 1) | 20 | 60 | 20 | 70 | 20 | 80 | ns |
| t_{dis} | Output Disable Time* (See Figure 2) | 10 | 35 | 10 | 50 | 10 | 60 | |
| t_{en} | Output Enable Time* (See Figure 2) | 5 | 35 | 5 | 50 | 5 | 60 | |

*NOTE: Output disable time is the time taken for the output to reach a high resistance state when either chip enable is taken high. Output enable time is the time taken for the output to become active when both chip enables are taken low. The high resistance state is defined as a point on the output waveform equal to a ΔV of 0.5V from the active output level.

SWITCHING WAVEFORMS

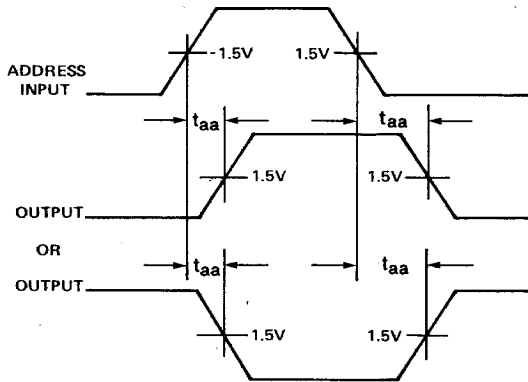

FIGURE 1: Access Time Via Address Inputs

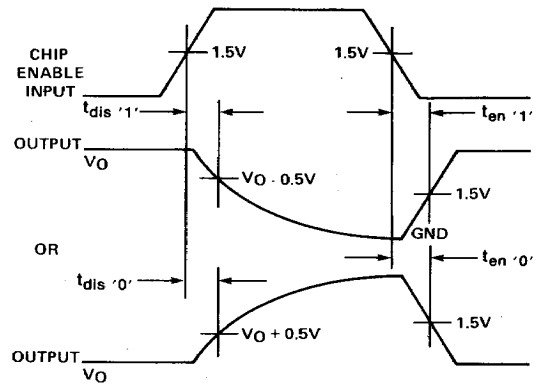

FIGURE 2: Output Enable And Disable Times

8

SWITCHING TIME TEST CONDITIONS

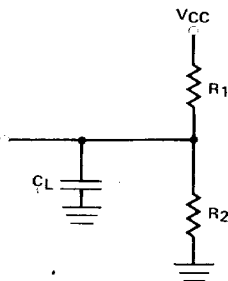

FIGURE 3: Output Load Circuit

| SWITCHING PARAMETER | IM5603 | | | IM5623 | | |
|------------------------|----------------|----------------|----------------|----------------|----------------|----------------|
| | R ₁ | R ₂ | C _L | R ₁ | R ₂ | C _L |
| t_{aa} | 300 Ω | 600 Ω | 30 pF | 300 Ω | 600 Ω | 30 pF |
| t_{dis} '1' | ∞ | 3.3 K Ω | 10 pF | ∞ | 600 Ω | 10 pF |
| t_{dis} '0' | 300 Ω | 600 Ω | 10 pF | 300 Ω | 600 Ω | 10 pF |
| t_{en} '1' | ∞ | 3.3 K Ω | 30 pF | ∞ | 600 Ω | 30 pF |
| t_{en} '0' | 300 Ω | 600 Ω | 30 pF | 300 Ω | 600 Ω | 30 pF |

INPUT CONDITIONS

Amplitude — 0V to 3V
 Rise and Fall Time — 5 ns From 1V to 2V
 Frequency — 1 MHz

TYPICAL SWITCHING CHARACTERISTICS

IM5603 ADDRESS TO OUTPUT ACCESS DELAY (t_{AA}) VS TEMPERATURE

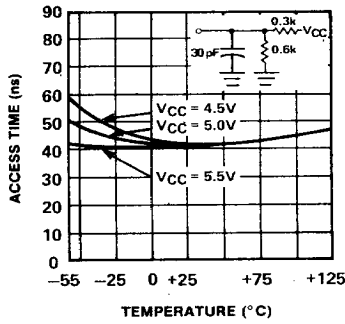

IM5603 CHIP ENABLE TO OUTPUT ACCESS DELAY (t_{EN}) VS TEMPERATURE

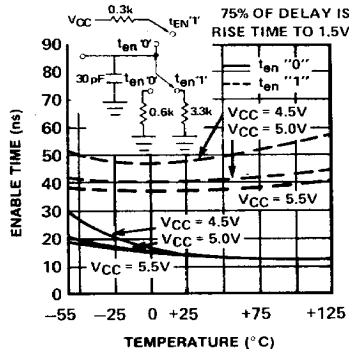

IM5603 CHIP ENABLE TO OUTPUT DISABLE TIME DELAY (t_{DIS}) VS TEMPERATURE

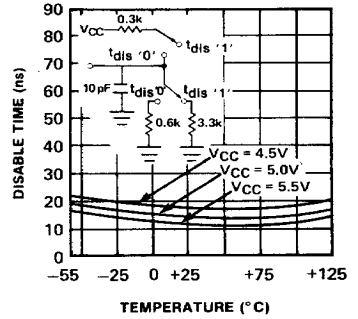

IM5623 ADDRESS TO OUTPUT ACCESS DELAY (t_{AA}) VS TEMPERATURE

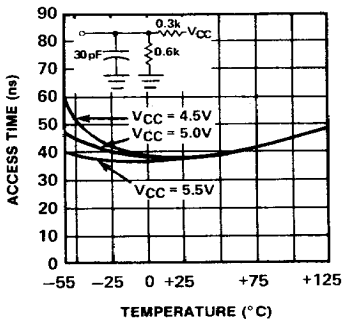

IM5623 CHIP ENABLE TO OUTPUT ACCESS DELAY (t_{EN}) VS TEMPERATURE

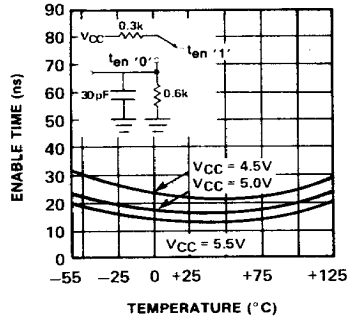

IM5623 CHIP ENABLE TO OUTPUT DISABLE TIME DELAY (t_{DIS}) VS TEMPERATURE

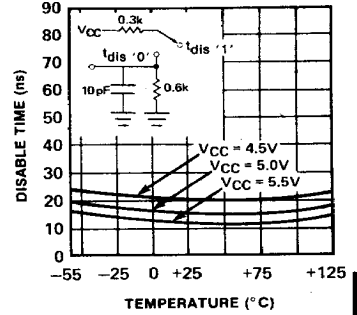

IM5603 DELAY INCREASE WITH LOAD CAPACITANCE

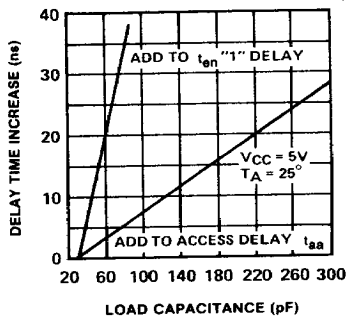

IM5623 DELAY INCREASE WITH LOAD CAPACITANCE

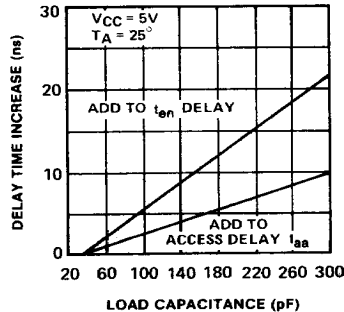

TYPICAL DC CHARACTERISTICS

IM5603 OUTPUT LOW CURRENT (I_{OL}) VS OUTPUT LOW VOLTAGE (V_{OL})

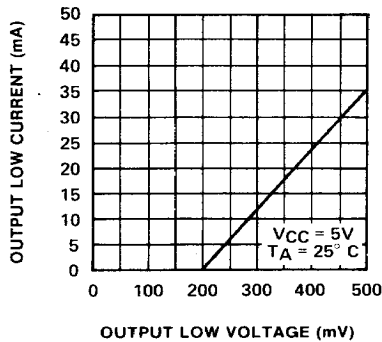

IM5623 OUTPUT LOW CURRENT (I_{OL}) VS OUTPUT LOW VOLTAGE (V_{OL})

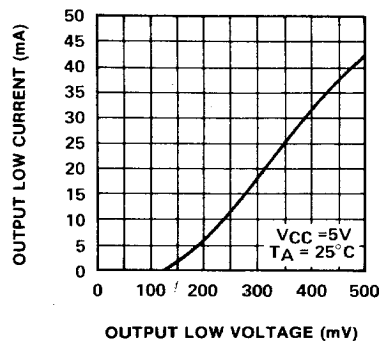

IM5603 OUTPUT HIGH CURRENT (I_{OH}) VS OUTPUT HIGH VOLTAGE (V_{OH})

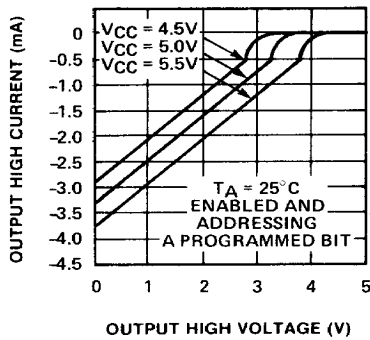

IM5623 OUTPUT HIGH CURRENT (I_{OH}) VS OUTPUT HIGH VOLTAGE (V_{OH})

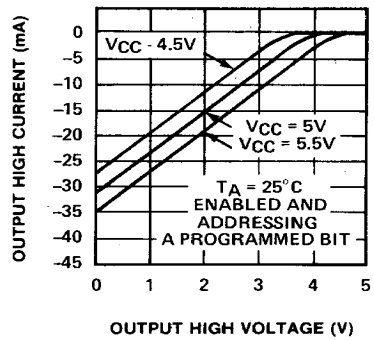

IM5603 OR IM5623 CHIP ENABLE INPUT CURRENT VS INPUT VOLTAGE

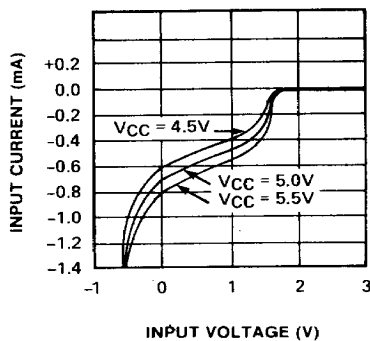

IM5603 OR IM5623 ADDRESS INPUT CURRENT VS INPUT VOLTAGE

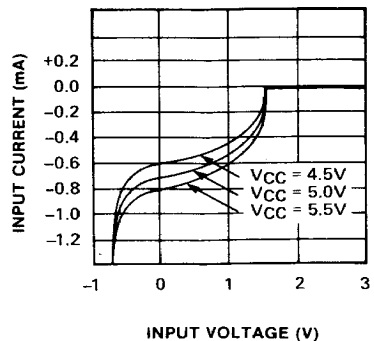

8

IM5603/IM5623

INTERMIL

OUTPUT STAGE SCHEMATICS

IM5603

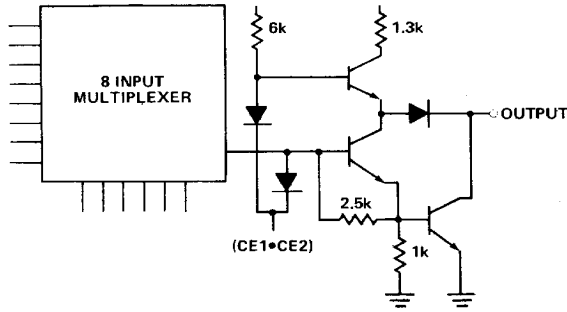

IM5623

