

October 1996

Emulation Board for S1207

Features

- To emulate S1207 chip and its derivatives, see data sheet PID 247.
- Driven by either 1.5 V x 4 battery or 5 - 6 V power supply.
- A 4x1 jumper header JP1 is provided to accept power source.
- A pair or strengthen wire (E1 & E2) is provided to accept the power source.
- 2 push button switches are provided to control the power on/off.
- Selectable (by JP2) auto power off function (after 60" no operation) is provided.
- A push button switch is provided to reset this M9026 board.
- A red LED lamp D3 is provided to indicate the power on or off.
- A 32-pin textool U3 is provided to store 27C010 EPROM (access time 120 ns or faster).
- 5 green LED lamps are provided on EAC area.
- 5 red LED lamps are provided on EAC area.
- 19 push button switches for triggers are provided on EAC area.
- A 2x1 jumper header JP4 is provided on EAC area to accept wires to speaker.
- A 3x1 jumper header JP5 is provided on EAC area to decide source for K1,2,3,4 triggers.
- A 3x5 jumper header is provided on EAC area to select LED lamps for 5 output pins or not.
- To be continued on page 3/6.

Description

By storing digitized sound data and options into 27C010 and inserting it onto U3, this MSM9026 board emulates the function of S1207 chip and its derivatives. The file for 27C010 content should be prepared by running program 9026pack.exe. The demanded external components are provided on board in specific EAC (External Application Component) area.

Board Layout

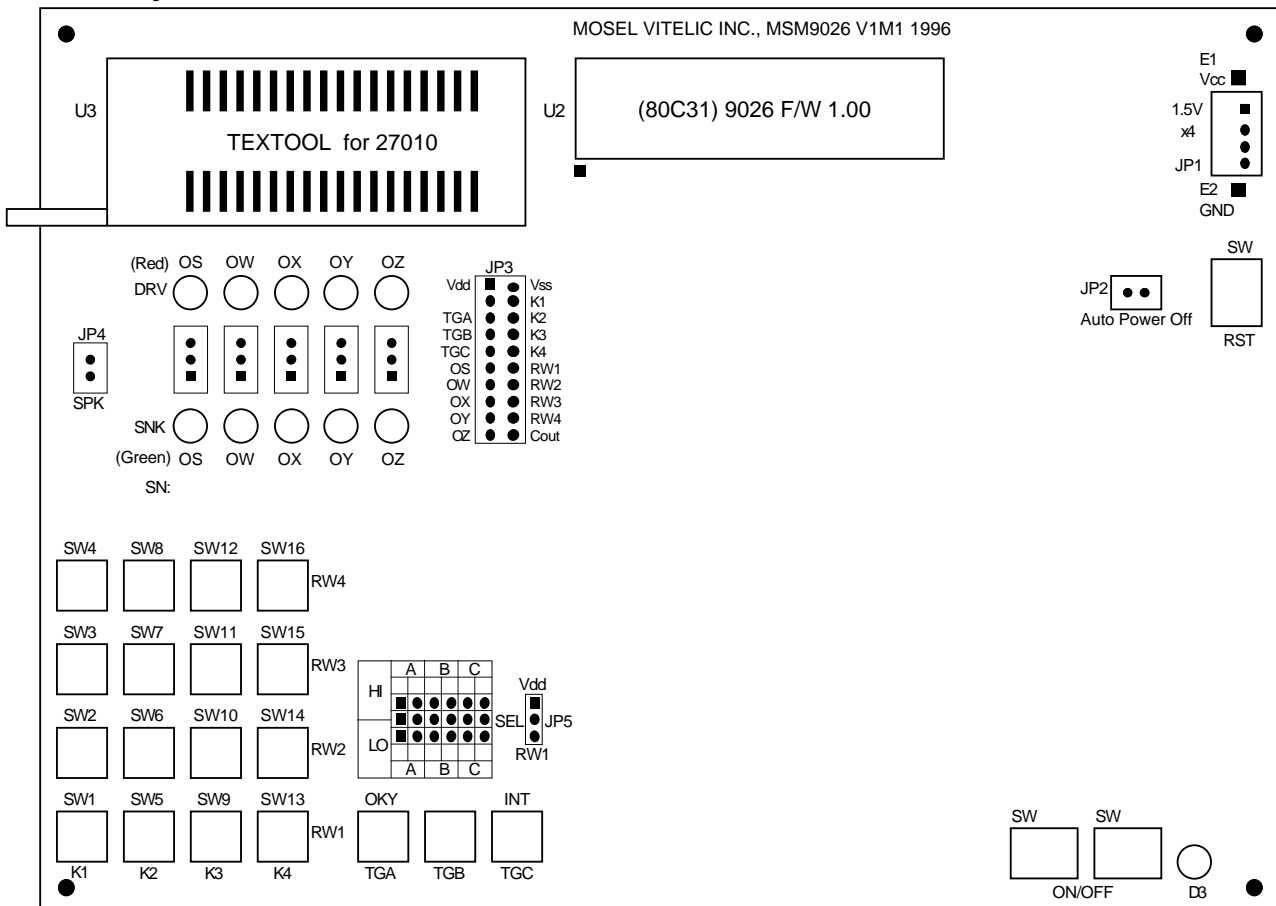

Block Diagram & Schematics

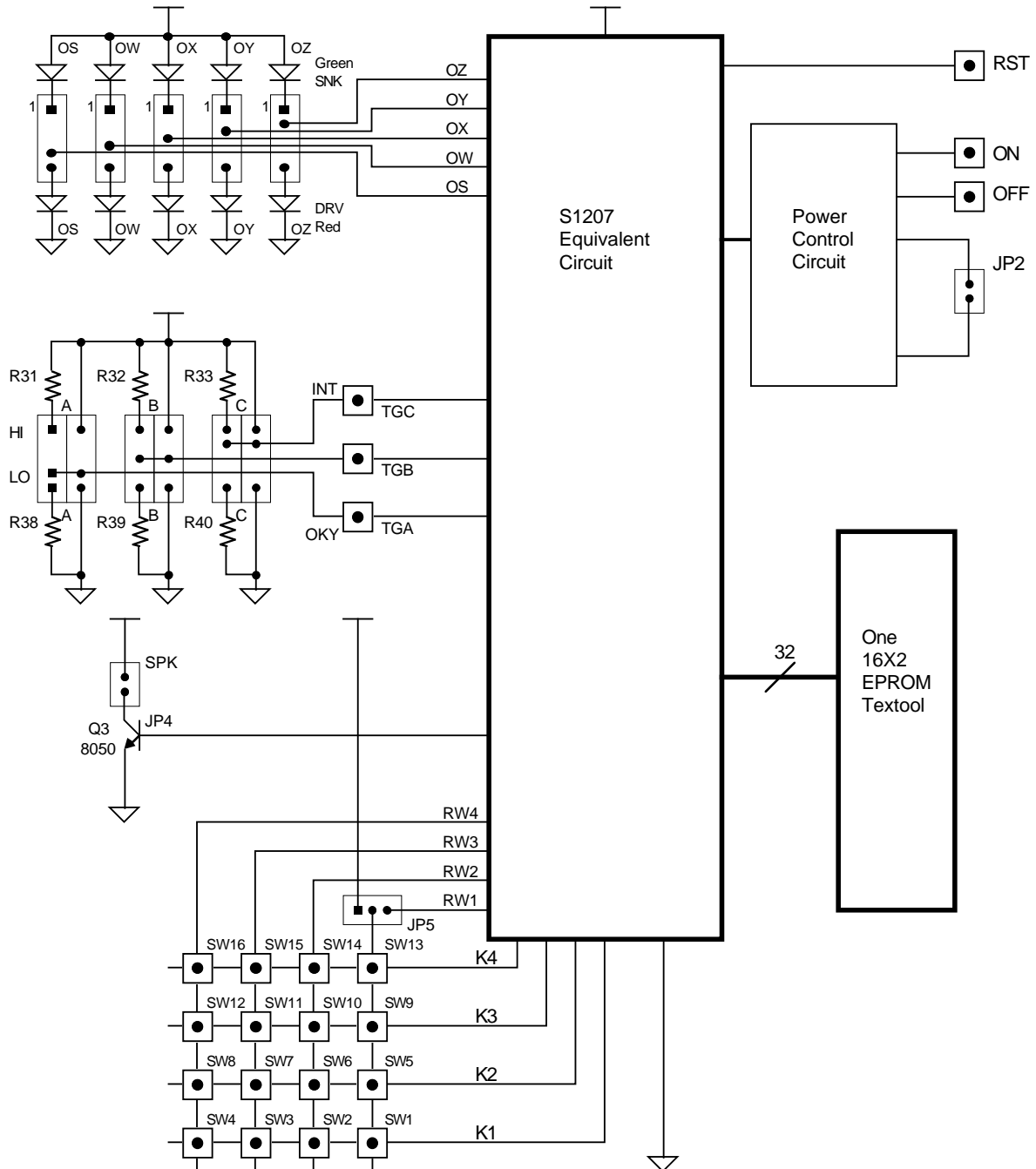

Features (continued)

- A 3x6 jumper header is provided on EAC area to select drive circuit for 3 trigger inputs.
- A transistor 8050 is provided on EAC area to drive the current running through speaker.
- The board's AC characteristics is not identical to chip's.
- The board's DC characteristics is not identical to chip's.
- Neither identical to S1207's derivatives.

DC Characteristics

Symbol	Parameter	Valid	Min	Typ.	Max.	Unit	Remark
V _{iL}	input low V	TGA,B,C			0.9	V	
V _{iH}	input high V	TGA,B,C	3.15			V	
V _{oL}	output low V	OS,W,X,Y,Z			0.1	V	
V _{oH}	output high V	OS,W,X,Y,Z	V _{cc} -0.1			V	
I _{iL}	input low I	TGA,B,C		-1		uA	
I _{iH}	input high I	TGA,B,C		1		uA	
I _{oL}	output high I	OS,W,X,Y,Z		4		mA	V _o =0.4V
I _{oH}	output high I	OS,W,X,Y,Z		-4		mA	V _o =V _{cc} -0.8
I _{co}	Current output	Cout		2.2		mA	5 V _{dd}
I _{co}	Current output	Cout		2.8		mA	6 V _{dd}

The DC characteristics of TGs input and outputs are the same as those of 74Cxx series.

AC Characteristics

Symbol	Parameter	Valid	Min	Typ.	Max.	Unit	Remark
t _{STP}	Stop pulse width	OS,W,X,Y,Z		30		ms	pitch independent
t _T	Trigger pulse width	TGA,B,C		10		ms	pitch = 0, SRI
t _T	Trigger pulse width	TGA,B,C		13		ms	pitch = 1, SRI
t _T	Trigger pulse width	TGA,B,C		15		ms	pitch = 2, SRI
t _T	Trigger pulse width	TGA,B,C		17		ms	pitch = 3, SRI
t _T	Trigger pulse width	TGA,B,C		20		ms	pitch = 4, SRI
t _T	Trigger pulse width	TGA,B,C		23		ms	pitch = 5, SRI
t _T	Trigger pulse width	TGA,B,C		25		ms	pitch = 6, SRI
t _T	Trigger pulse width	TGA,B,C		27		ms	pitch = 7, SRI
f		LED		198%		f led	pitch = 0, SRI
f		LED		158%		f led	pitch = 1, SRI
f		LED		133%		f led	pitch = 2, SRI
f		LED		115%		f led	pitch = 3, SRI
f		LED		100%		f led	pitch = 4, SRI
f		LED		88%		f led	pitch = 5, SRI
f		LED		80%		f led	pitch = 6, SRI
f		LED		73%		f led	pitch = 7, SRI

SRI := Sample Rate Independent.

LED selection by 3X5 Jumper

1		Red LED.S is used for output OS		6		Green LED.S is used for output OS	
2		Red LED.W is used for output OW		7		Green LED.W is used for output OW	
3		Red LED.X is used for output OX		8		Green LED.X is used for output OX	
4		Red LED.Y is used for output OY		9		Green LED.Y is used for output OY	
5		Red LED.Z is used for output OZ		10		Green LED.Z is used for output OZ	

Auto Power off control

	JP2 open	Power always on
	JP2 connected	Auto power off

Trigger Drive Selection by 3X6 Jumper

1		Use Vdd to drive TGA through 10K ohm (R31) and SW-TGA	
		Use Vss to drive TGA through 10K ohm (R38) and SW-TGA	
		Use Vdd to drive TGA through SW-TGA	
		Use Vss to drive TGA through SW-TGA	
2		Similar operation as TGA's	
3		Similar operation as TGA's	

Before Operating 9026

To prepare voice file(s)

To prepare up to 32 voice files by MES 2.0 or 3.0. These files must be 8-bit PCM file.

To prepare a filled PRF

To write down your demand options on PRF (product request form) is strongly recommended before you are running 9026pack.exe.

To prepare a source text

Using commercial text editor on personal computer, you can set up a source text in the format defined in 9026pack software user's manual (pid 392 10/96). In this source text, you can define the both word sections and sentence tables. This source text must have the file extension .SRC. Most of mask options can be defined on the screen in 9026pack.exe. The entry dependent options could be defined inside source text.

To have a compiled binary file

Running 9026pack.exe and entering keystrokes as prompt, you can easily define the options and read in the source text. Completing as the screen tells, you can get a compiled binary file in your specified file name. Its file extension is always .BIN.

To have 27C010 programmed

Programming this .BIN file into an 27C010 chip by commercial EPROM programmer, you have it ready.

To insert this 27C010

To insert this EPROM chip into textool U3 of 9026 board in right direction.

To set up LED selections

To set up LED connection by jumper 3x5 if needed.

To set up Trigger Drive

To set up trigger drive circuit as your requirement on jumper 3x6. Without the drive source (either high or low, either R or bare wire) the switch keeps floating and never be capable to activate the trigger. Without right polarity of drive source you can neither trigger the sound and you may hurt this 9026 board.

To configure demanded wires

Ensuring you have both 1.5Vx4 power and speaker well connected, this board are ready to work. There are push-button switches to turn on or off the power. Red LED lamp D3 tells the power on. JP2 enables the auto power off function.

Operation Flow

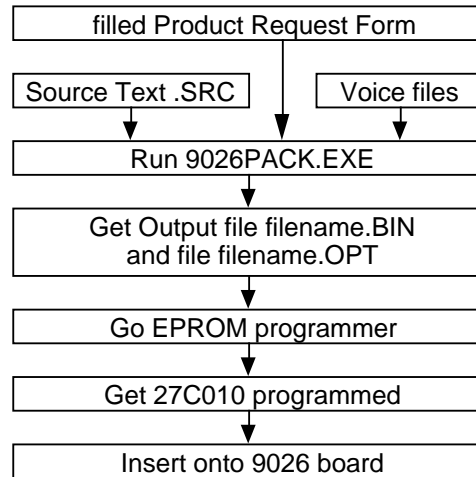

Warning

Output pin definition restricted: If you select LED dynamic flash, then the M9026 output level will remain the same as the output level of the previous entry.

Trigger pin definition restricted: M9026 performs two trigger options only, active high & pull low & low latch as well as active low & pull high & high latch.

The M9026 debounce time (min. trigger pulse width) is shown as table in page 3/6, not optional as chip.

Misc

- Fuse : Not Available
- Power : 1.5V x 4 (battery) or 6 VDC power supply
- Dimension : (LxWxH) 160x115x20 mm
textool included
- Weight : 150 g
- Demonstration Kit

Taiwan
#1, Creation Road I,
Science - based Industrial Park,
Hsinchu, 30077
Taiwan, ROC
"audio_reply@ccmail.mosel.com.tw"
TEL: 886-3-5770055
FAX: 886-3-5772788
FAX: 886-3-5784732

Taipei
7F, #102 Sec. 3,
Ming Chung E. Road,
Taipei, 105
Taiwan, ROC
TEL: 886-2-5451213
FAX: 886-2-5451214

Hongkong
#19 Dai Fu Street,
Taipo Industrial Estate,
Taipo, N.T.
Hongkong
TEL: 852-2388-8277(MKO)
TEL: 852-2665-4883
FAX: 852-2664-2406
FAX: 852-2770-8011(MKO)

U.S.A.
#3910 North First Street,
San Jose,
CA. 65134-1501
U.S.A.
TEL: 1-408-433-6000
FAX: 1-408-433-0952