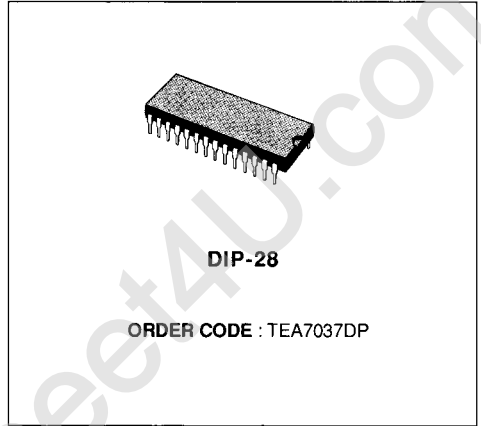


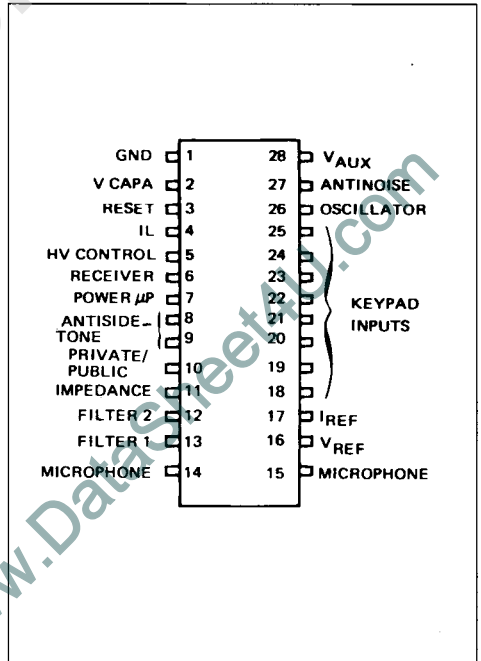


SPEECH AND TONE CIRCUIT

- AUTOMATIC LINE LENGTH RECEIVING AND SENDING GAIN CONTROL
- AUTOMATIC LINE LENGTH TRACKING ANTI-SIDETONE SYSTEM
- ADJUSTABLE MICROPHONE AND EARPHONE AMPLIFIER GAIN
- MEETS FRENCH VOLTAGE/CURRENT LIMITATIONS IN SPEECH AND RING MODE
- ADAPTED TO EVERY KIND OF EARPHONE TRANSDUCER
- MUTE IN EMISSION AND RECEPTION
- PABX POSITION
- TWO KEYS ROLL OVER PROVIDED
- ADJUSTABLE OUTPUT TONE LEVEL
- CLICK FREE SWITCH OVER FROM SPEECH TO DIALING MODE & VICE-VERSA



PIN CONNECTION



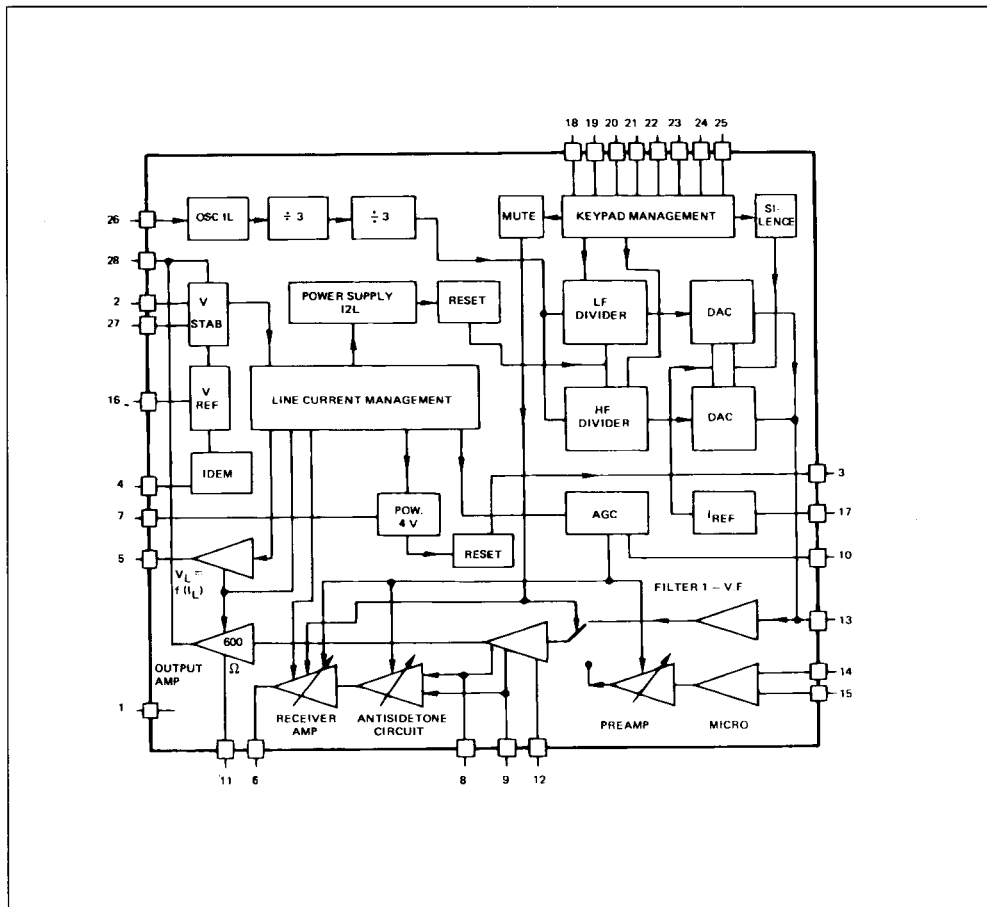
DESCRIPTION

Specially designed for telephone set applications this 28 pins IC provides :

- a) Transmission and line adaptation
- b) F.V. generation
- c) Power supply for peripherals
- d) Interface with MCU

It meets the French Specifications for handset homologation level 1.

BLOCK DIAGRAM



ABSOLUTE MAXIMUM RATINGS

Symbol	Parameter	Value	Unit
V_{cse}	Supply Voltage	8.5	V
P_{tot}	Power Dissipation	800	mW
T_{oper}	Operating Temperature Range	- 25 to 65	°C
T_{stg}	Storage Temperature Range	- 55 to 150	°C

PIN DESCRIPTION

N°	Name	Description
1	G _{ND}	Ground
2	V _{capa}	C7 : Voltage Stabilizer Filtering Capacity
3	Reset	Microprocessor Reset
4	I _L	R17/C6 Sets Call Frame Width
5	H _v Control	Output Controlling HV Stage
6	Receiver	Receiver Output
7	Power Up	Stabilized Power for Peripheral Circuits
8	Antisidetone	Antisidone Network Input for Long Lines (3.5km)
9		Antisidone Network Input for Short Lines (0.5km)
10	Private/Public	Gain Control Inhibition with Respect to line Length
11	Impedance	R7 Sets Dynamic Impedance
12	Filter 2	Second Filter Input for Voice Frequencies
13	Filter 1	First Filter Input for Voice Frequencies
14-15	Microphone	Microphone
16	V _{ref}	Reference Voltage
17	I _{ref}	R9 Sets Internal Source Reference Current
18	Keypad Inputs	" D " 941 Hz Logic Input
19		" C " 852 Hz Logic Input
20		" B " 770 Hz Logic Input
21		" A " 697 Hz Logic Input
22		" E " 1209 Hz Logic Input
23		" F " 1336 Hz Logic Input
24		" G " 1477 Hz Logic Input
25		" H " 1633 Hz Logic Input
26	Oscillator	Oscillator Input
27	Antinoise	C8 Decreases Line Noise Level
28	V _{aux}	V _{CC} : Low Voltage Line

ELECTRICAL CHARACTERISTICS ($T_{amb} = 25^{\circ}\text{C}$)

Symbol	Parameter	Test Conditions	Min.	Typ.	Max.	Unit
V_C	Stabilized Voltage (pin 2)	$I_L = 28\text{mA}$ (see figs. 9, 10)	2.6	2.8	2.95	V
I_{DEM}	Charging Current (pin 2)			2.6		mA
I_r	Line Current Regulation for HV Control (pin 5)	Pin 4 = Pin 2 = GND $I_L = 150\text{mA}$ $I_L = 105\text{mA}$	150		5	μA
		Pin 4 ON ; Pin 2 = GND $I_L = 75\text{mA}$	150			μA
		Pin 4 ON ; Pin 2 ON $I_L = 60\text{mA}$ $I_L = 16\text{mA}$ $28\text{mA} < I_L < 50\text{mA}$	150		100	μA nA
I_r/I_L			0.9	1.0	1.1	$\mu\text{A}/\text{mA}$
I_{int}	Internal Bias Current (pin 28)	$I_L = 28\text{mA}$; (see figs. 9, 10) $R9 = 16.2\text{K}\Omega$ $(V_{28} = R6 * I_{int} + V_C)$	470	510	550	μA
V_{ref}	Reference Voltage	$I_L = 28\text{mA}$	1.35	1.42	1.49	V
I_{ref}	Current at V_{ref}		- 10		100	μA
V_{MP}	Stabilized Supply at Pin 7	(see fig. 11)	3.7	4	4.2	V
I_{CMP}/I_{LI}	Charging Current at Pin 7	Pin 4 = Pin 2 = GND $I_{L1} = I_L - I_{dem}$ (note 2)	0.7			mA/mA
I_{SMP}	Static Current at Pin 7	$I_L = 6\text{mA}$	0.5	-	-	mA
		$I_L > 25\text{mA}$	3.15	3.5	-	mA
		$I_L > 25\text{mA} + AC$	1.6	1.75	-	mA
I_{IMP}	Internal Consumption	(see fig. 11)	90	110	130	μA

RESET MICROPROCESSOR (see fig. 12)

V_{RH}	High Threshold		$0.82 \times V_{PM}$			V
V_{RB}	Low Threshold		2.83		$0.805 \times V_{PM}$	V
V_{RSH}	Output High	Reset = 1	$0.9 \times V_{PM}$			V
V_{RSB}	Output Low	Reset = 0			$0.1 \times V_{PM}$	V

AC CHARACTERISTICS (see figs. 12, 13, 14 and 15)

G_{EL}	Tx Gain at Long Line	$I_L = 28\text{mA}$	54	55	56	dB
G_{EC}	Tx Gain at Short Line	$I_L = 44\text{mA}$	47	49	51	dB
DE	Distortion in I_x	$I_L = 28$ to 44mA $V_L = 1.5\text{dBm}$ $V_L = 4\text{dBm}$			3 10	% %
Z_E	Microphone Input Impedance	Symmetric Mode	1.82	2.15	2.47	$\text{K}\Omega$
B_{EP}	Tx Psophometric Noise	$Z_{IN} = 2\text{K}$; $I_L > 28\text{mA}$		- 69		dBmp
R_E	Tx Attenuation M.F. and Silence Modes	$I_L > 28\text{mA}$	60			dB
CM_{RR}	Common Mode Rejection Ratio			60		dB

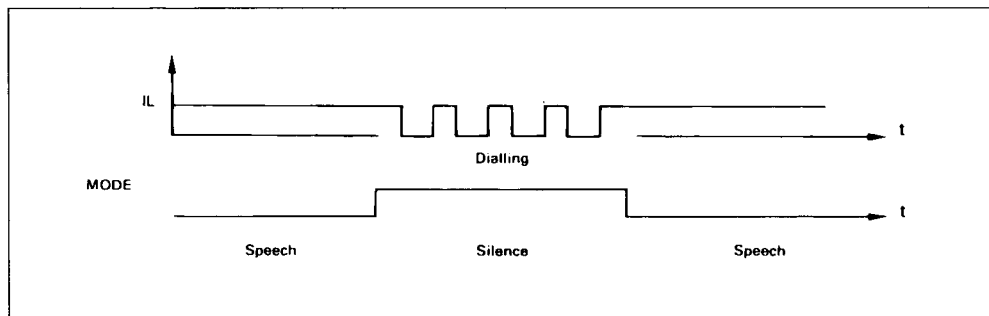
ELECTRICAL CHARACTERISTICS (Continued)

Symbol	Parameters	Test Conditions	Min.	Typ.	Max.	Unit
G_{RL}	Rx Gain at Long Line	$I_L = 28\text{mA}$	28.5	29.5	30.5	dB
G_{RC}	Rx Gain at Short Line	$I_L = 44\text{mA}$	27.5	23.5	25.5	dB
D_R	Distortion in R_x	$I_L = 28$ to 44mA $V_{EC} = 440\text{mV}$ $V_{EC} = 790\text{mV}$			3 10	% %
B_{RP}	R_x Noise	$I_L > 28\text{mA}$; $R_{EC} = 600\Omega$		- 74		dB mp
G_{AL}	Side Tone at Long Line	$I_L = 28\text{mA}$	22			dB
G_{AC}	Side Tone at Short Line	$I_L = 44\text{mA}$	26			dB
Z_{AC}	AC Impedance	$I_L > 28\text{mA}$	500	600	700	Ω

DTMF GENERATOR (see fig. 16)

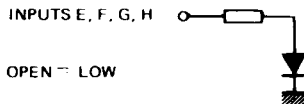
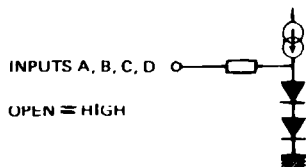
D_{FV}	Frequency Dispersion		- 0.5	-	+ 0.5	%
N_{FB}	Low Frequency Group		- 10	-	- 6	dBm
N_{FH}	High Frequency Group		- 8	-	- 4	dBm
P_{FV}	Pre-Emphasis		1	2	3	dB
C_{FV}	Voice Frequency Monitoring		28	35	42	dB

In pulse dialling the receiver mute is the silence mode.



FUNCTIONAL DESCRIPTION

Logic inputs equivalent diagrams



LOGIC TABLE - KEYBOARD MODE

Symbol	Inputs								Voice Frequencies (Hz)	Mute	Notes
	A	B	C	D	E	F	G	H			
-	H	H	H	H	L	L	L	L	-	Off	a
-	L	H	H	H	L	L	L	L	697	On	b
-	H	L	H	H	L	L	L	L	770	On	
-	H	H	L	H	L	L	L	L	852	On	
-	H	H	H	L	L	L	L	L	941	On	
-	H	H	H	H	H	L	L	L	1209	On	
-	H	H	H	H	L	H	L	L	1336	On	c
-	H	H	H	H	L	L	H	L	1447	On	
-	H	H	H	H	L	L	L	H	1633	On	
"1"	L				H				697 + 1208	On	
"2"	L					H			697 + 1336	On	d
"3"	L						H		697 + 1477	On	
"A"	L							H	697 + 1633	On	
"4"		L			H				770 + 1209	On	
"5"		L				H			770 + 1336	On	
"6"		L					H		770 + 1477	On	
"B"		L						H	770 + 1633	On	
"7"			L		H				852 + 1209	On	
"8"			L			H			852 + 1336	On	
"9"			L				H		852 + 1477	On	
"C"			L					H	852 + 1633	On	
"*"				L	H				941 + 1209	On	
"0"				L		H			941 + 1336	On	
"#"				L			H		941 + 1477	On	
"D"				L				H	941 + 1633		

Notes : a. Conversation mode.

b. Test mode.

Low frequencies.

c. Test mode.

High frequencies.

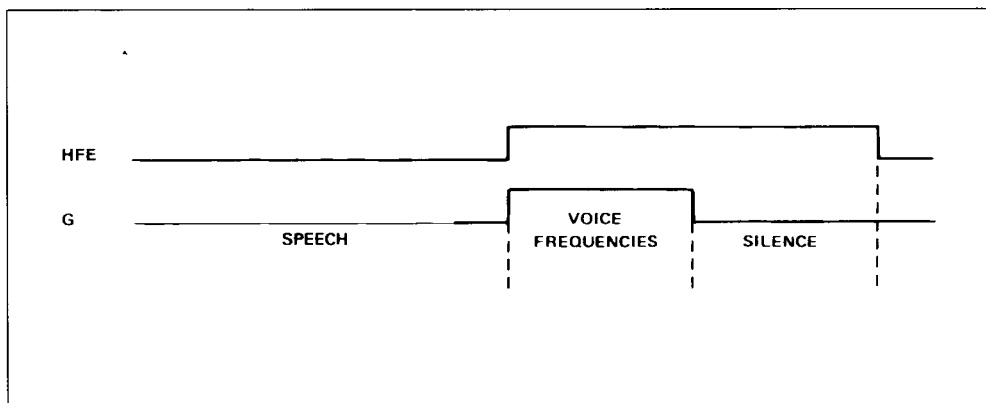
d. If one of inputs E, F, G, H, is high, the others are low.

If one of inputs A, B, C, D, is low, the other are high.

LOGIC TABLE - MICROPROCESSOR MODE

Symbol	Inputs								Voice Frequencies (Hz)	Mute	Notes
	A	B	C	D	E	F	H	G			
-	H	H	H	H	L	L			-	Off	e
-	X	X	X	X	H	L			-	On	f
" 1 "	H	H	H	H	H	H			697 + 1209	On	
" 2 "	H	H	H	L	H	H			697 + 1336	On	
" 3 "	H	H	L	H	H	H			697 + 1477	On	
" A "	H	H	L	L	H	H			697 + 1633	On	
" 4 "	H	L	H	H	H	H			770 + 1209	On	
" 5 "	H	L	H	L	H	H			770 + 1336	On	
" 6 "	H	L	L	H	H	H			770 + 1477	On	
" B "	H	L	L	L	H	H			770 + 1633	On	
" 7 "	L	H	H	H	H	H			852 + 1209	On	
" 8 "	L	H	H	L	H	H			852 + 1336	On	
" C "	L	H	L	L	H	H			852 + 1477	On	
" C "	L	H	L	L	H	H			852 + 1633	On	
" * "	L	L	H	H	H	H			941 + 1209	On	
" 0 "	L	L	H	L	H	H			941 + 1336	On	
" # "	L	L	L	H	H	H			941 + 1477	On	
" D "	L	L	L	L	H	H			941 + 1633	On	

Notes : e. Conversion mode.
f. Silence setting.



PUBLIC / PRIVATE

When a resistor is inserted between pin 10 and ground, the transmission and receiving efficiency control and antisidetone variation are inhibited with respect to line current.

The transmission and receiving gains may vary from

Figure 1 : Transmission and Receiving Gain Attenuation.

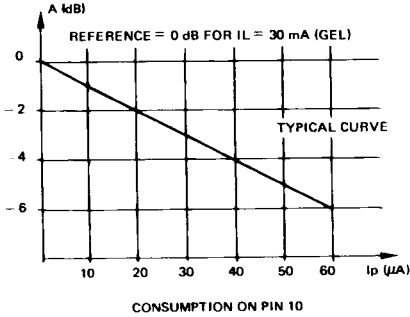
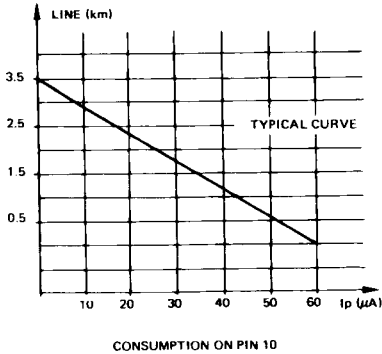


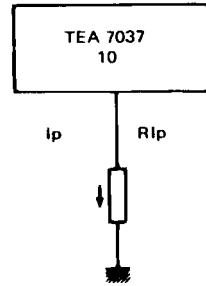
Figure 2 : Equivalent Antilocal Network.



$G_{max}(gel)$ to G_{max} 6 dB (Gec) with respect to the resistance value.

The equivalent antisidetone is related to the gain set by R_{Ip}

Figure 3 .



$$R_{Ip} \text{ in MW} = \frac{7.8}{I_p \mu A}$$

For $R_{Ip} = 390K$ to 1%
 $DG = -2dB \pm 0.4dB$

Figure 4.

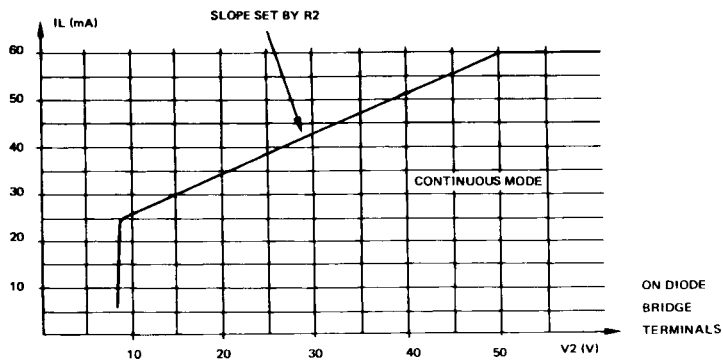


Figure 5.

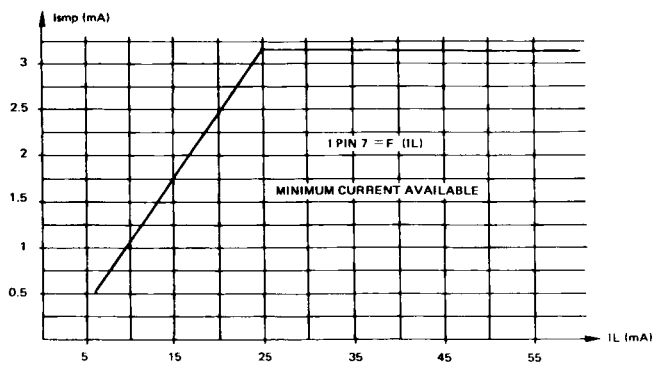


Figure 6.

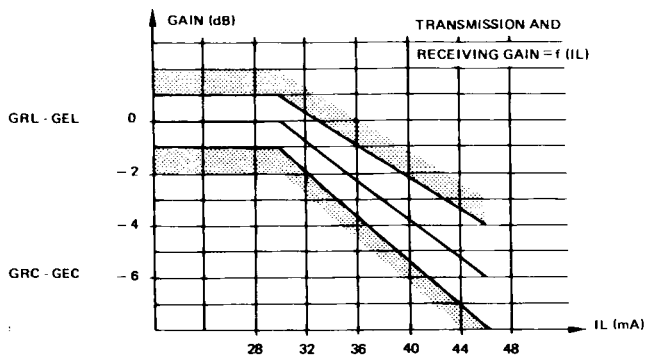
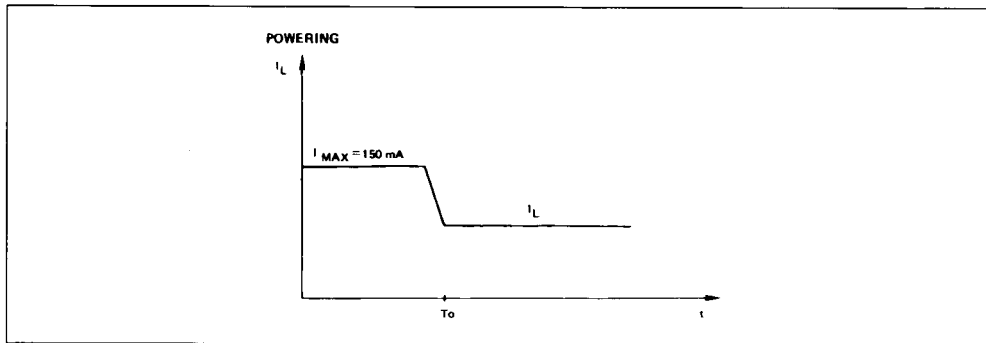


Figure 7 : To it set by : R17 · C6 (pin 4) or C7 (pin 2).

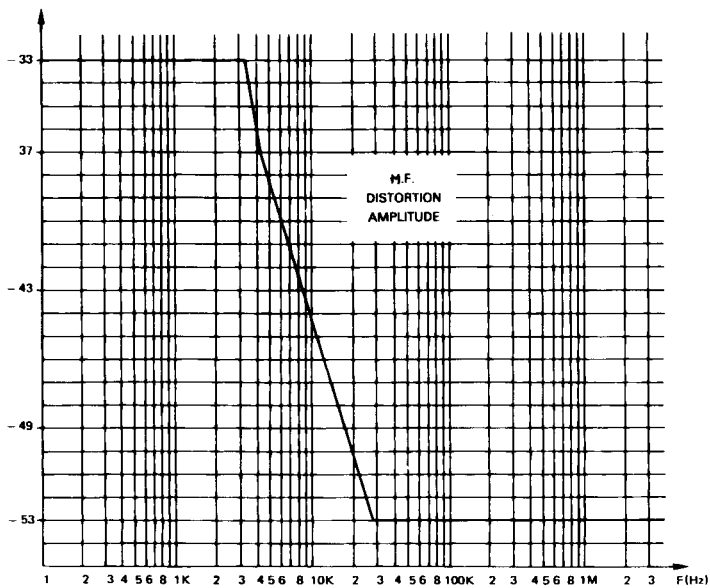


The TEA can stand the capacitive loads on all its pins, except pin 26 (oscillator).

It is obvious that these capacitors can change the circuits alternating and/or transient behavior.

Pin	Name	Max. Value (grounded)	Comments
1	Ground		
2	V _{capa}	220μF	
3	Reset	470μF	
4	I _L = 120 or 60ms	2.2μF	
5	H _V Control	Few nF Max.	In parallel with the capacitor across pin 28 and pin 1, hence changes impedance & circuit time constants.
6	Receiver	100nF Max.	In Parallel on the Receiver
7	Pow μP	470μF	
8 9	Anti Local	10nF	Receiver Signal Filter
10	Private/Public	47nF	
11	Impedance	33 pF Max.	Provides a high pass, hence increases DTMF harmonics & noise above cut-out frequency.
12	Filter 2	Few pF Max.	Changes Refilter Impedance & Time CS ¹
13	Filter 1	82nF	Should not be changed (preemphasis).
14 15	Microphone	100nF	
16	V _{REF}	10μF	
17	I _{REF}	680pF Max.	
18 19 20 21 22 23 24 25	Keyboard Inputs	10nF Max.	Bear Time Constants in Mind
26	Oscillator	NO	
27	Antinoise	2.2nF	
28	Vaux	Few nF	Cf. Comment Pin 5

Figure 8 : DTMF Harmonic Distortion vs. Frequency.



COMPONENTS VALUES (for figures 9 to 16)

R1	10 Ω	C1	2.2nF
R2	12M Ω	C2	4.7nF
R3	100k Ω	C3	1nF
R4	4.7M Ω	C4	100 μ F
R5	220k Ω	C5	.
R6	5.9k Ω	C6	.
R7	.	C7	.
R8	.	C8	.
R9	16.2k Ω	C9	/ 1 μ F
R10	.	C10	/ 1 μ F (depending on μ P)
R11	.	C11	68nF
R12	.	C12	1 μ F
R13	.	C13	= 6.8nF
R14	220k Ω	C14	- 3.3 μ F
R15	845 Ω	C15	- 2.2nF
R16	220 Ω	C16	- 2.2nF
R17	820k Ω	C17	= 10 μ F
R18	75 Ω	C18	= 2.2 μ F
R1P	390k Ω	C19	= 470nF
RuP	5.6k Ω		
Zec	- 220 Ω	D1	ZENER 15V
		D2	BAT43
T1	MJE340	D3	BAT43
T2	PBF259		
T3	PBF493S	QUARTZ	3.58MHz

• ZL = 600W

- R7	= 0	- C5	= 27pF
- R8	= 124k Ω	- C6	= 1nF
- R10	= 0	- C7	= 27pF
- R11	= 124k Ω	- C8	= 1nF
- R12	= 3.9k Ω		
- R13	= 3.9k Ω		

• 0.4mm France cable varying between 0km and 3.5km.

- R7	56k Ω	- C5	= 560pF
- R8	124k Ω	- C6	= 4.7nF
- R10	10k Ω	- C7	= 100pF
- R11	115k Ω	- C8	= 2.2nF
- R12	4.99k Ω		
- R13	3.6k Ω		

- R12 and R13 enable reception gain adjustment for adaptation to various transducers/
- R16 enable transmission gain equipment for adaptation to various transducers.

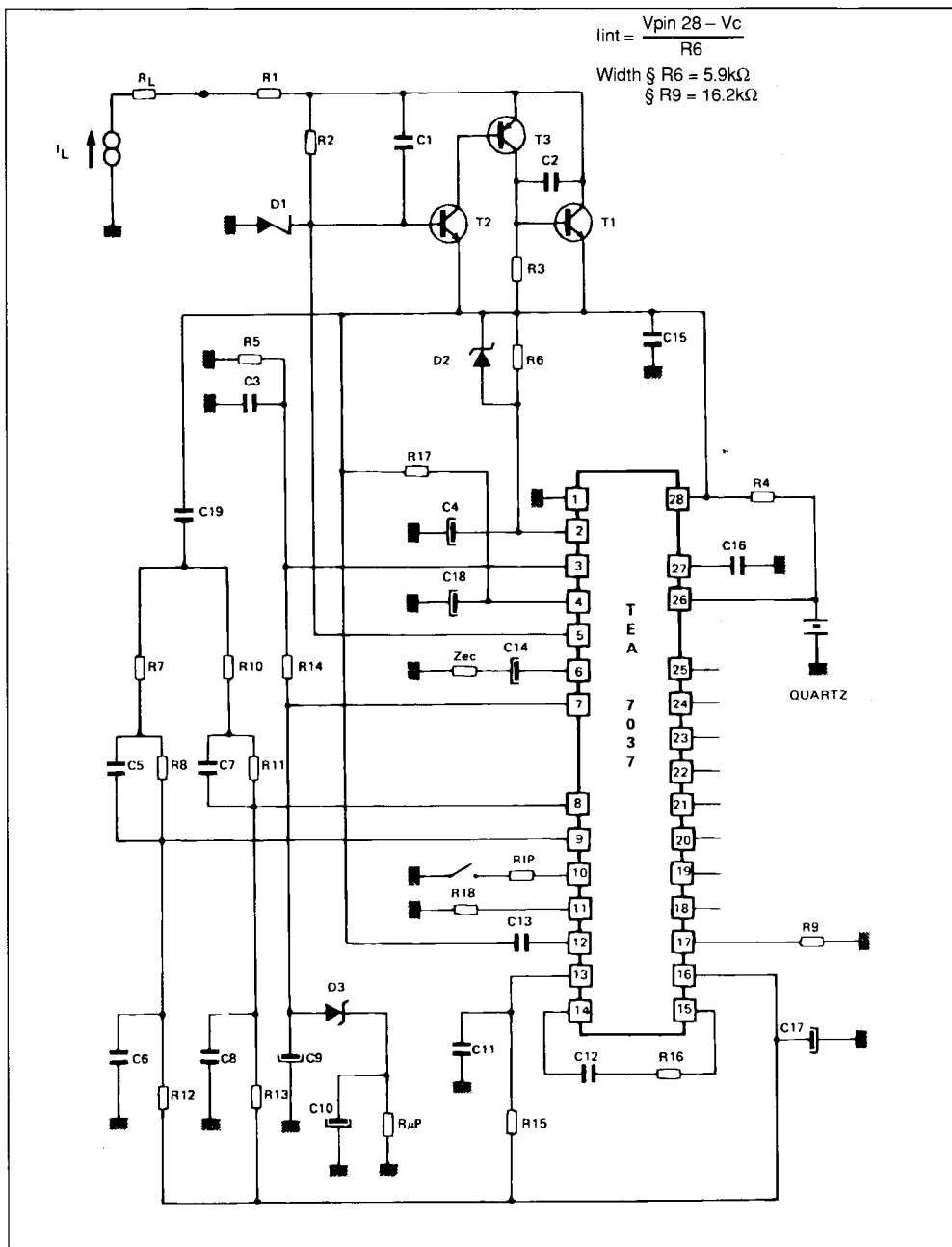
Figure 9 : V_C , I_{int} , V_{ref} .

Figure 10 : Idem I.

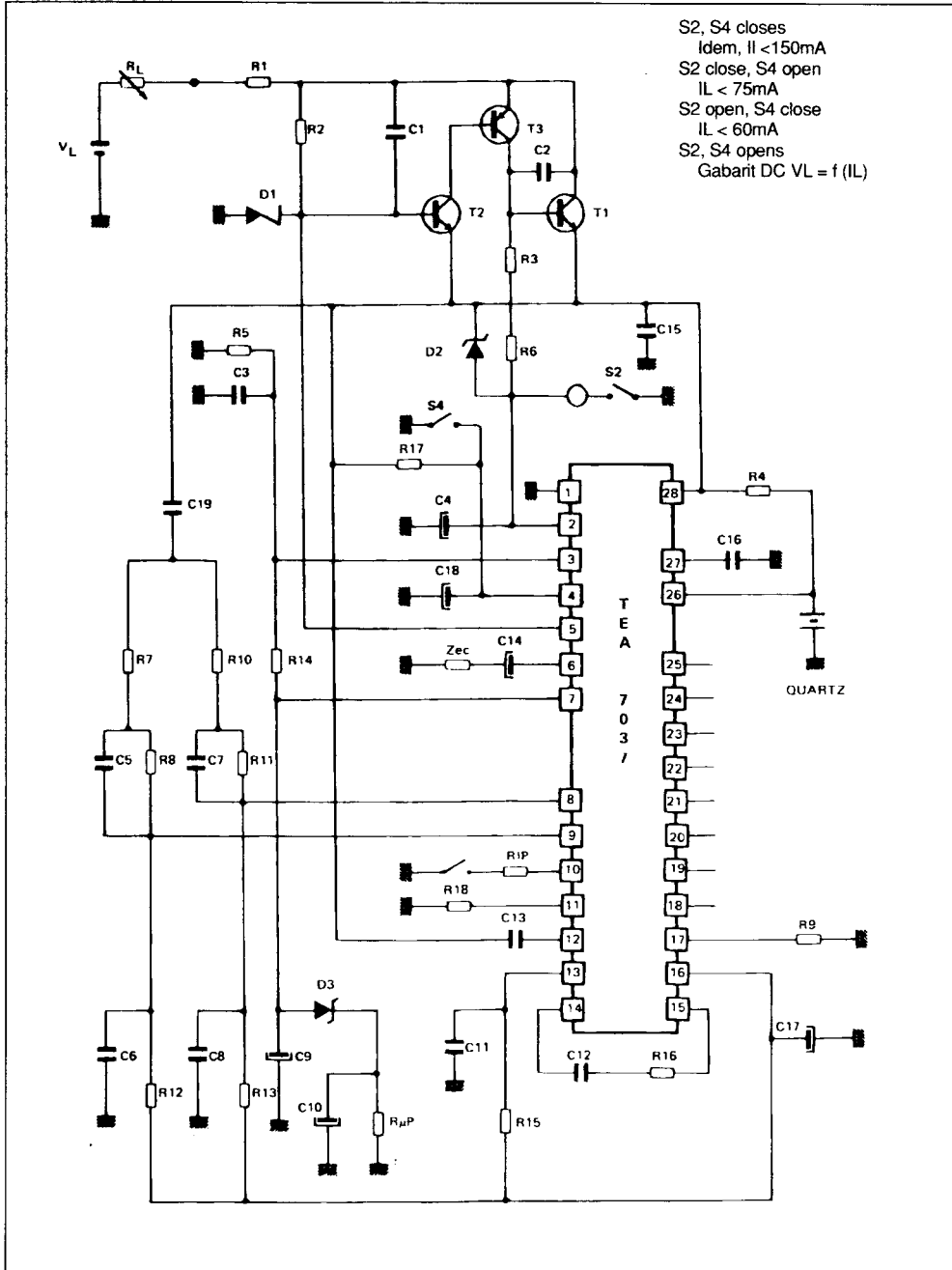


Figure 11.

Icmp, Vmp, Ismp, limp,
Vrh, Vrb, Vrsh, Vrsb.
S2, S4, S7 closes

Icmp
S2, S4, S7 opens
Vmp, Ismp

Limp by the time discharge of C9
when the line power is cut off.

Reset microprocessor

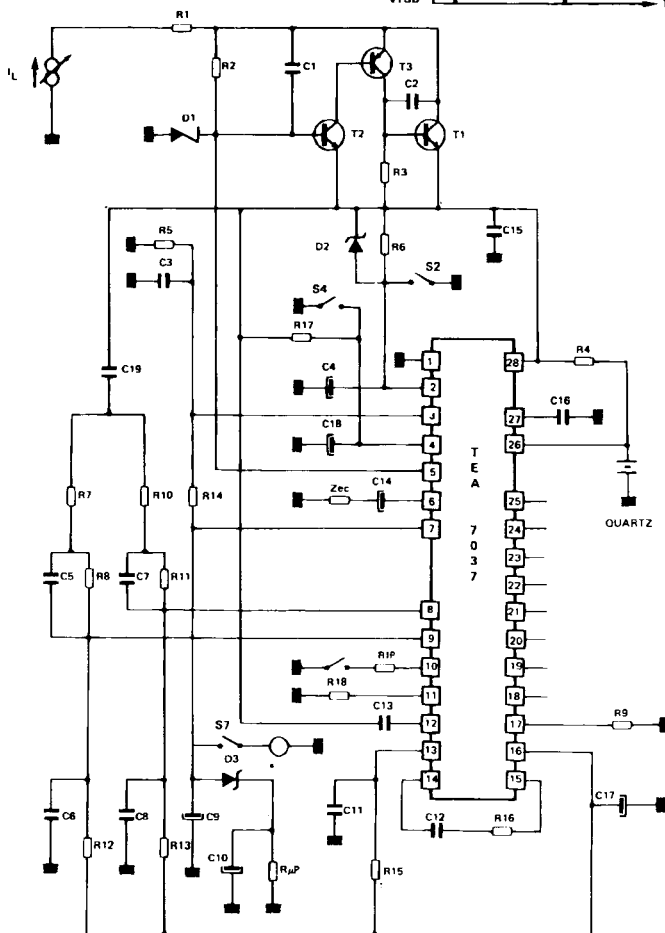
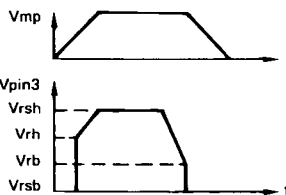


Figure 12.

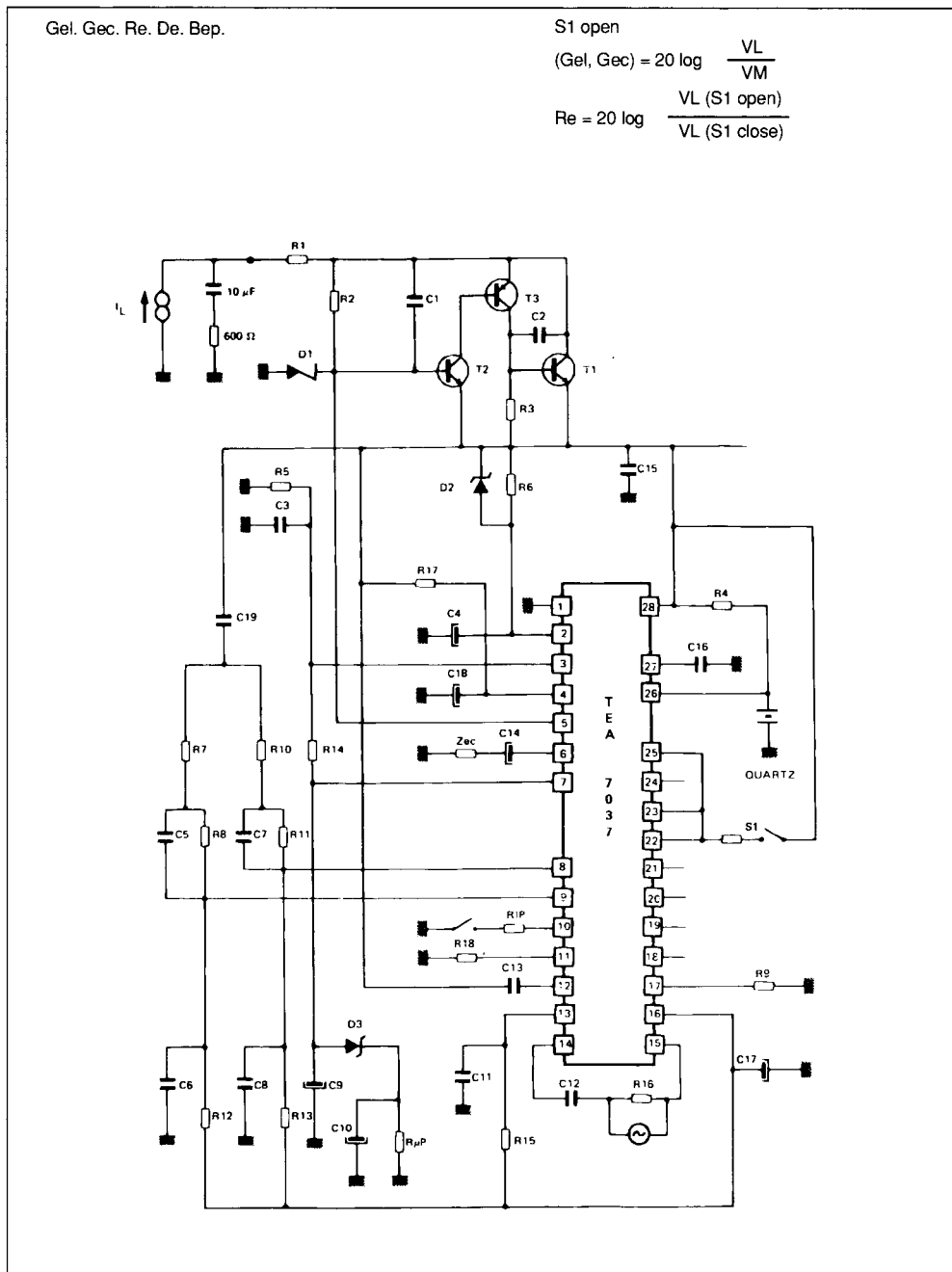


Figure 13 .

$$G_{rl}, G_{rc}, D_r, B_{rp},$$

$$G_{RL} = 20 \log \frac{V_{pin6}}{V_{pin8}}$$

$$G_{rc} = 20 \log \frac{V_{pin6}}{V_{pin9}}$$

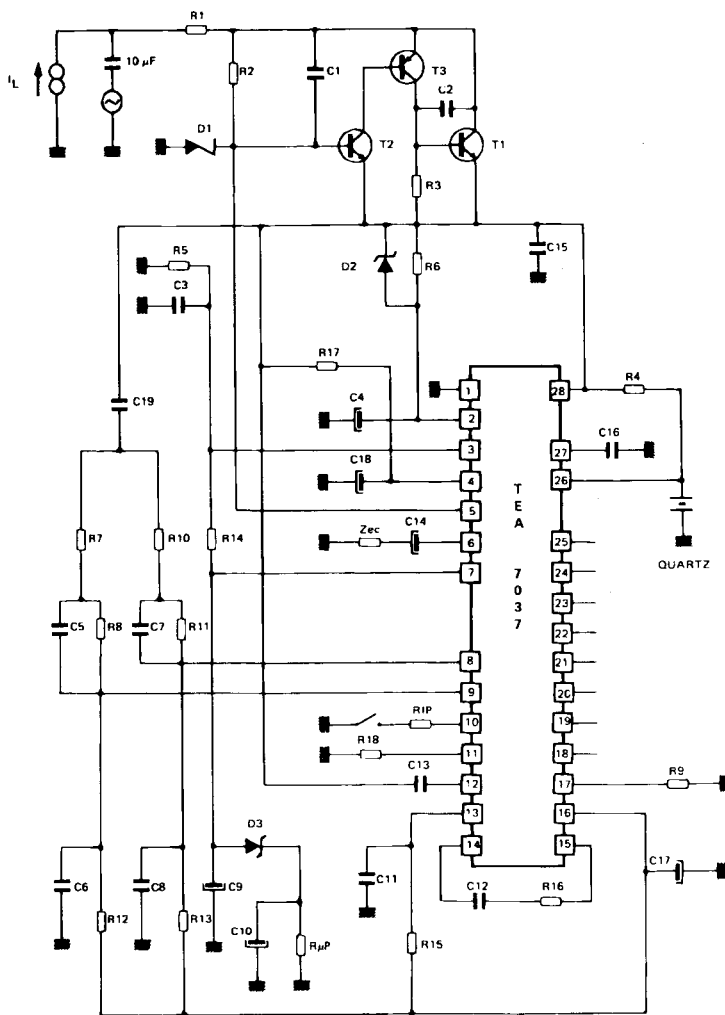


Figure 14 .

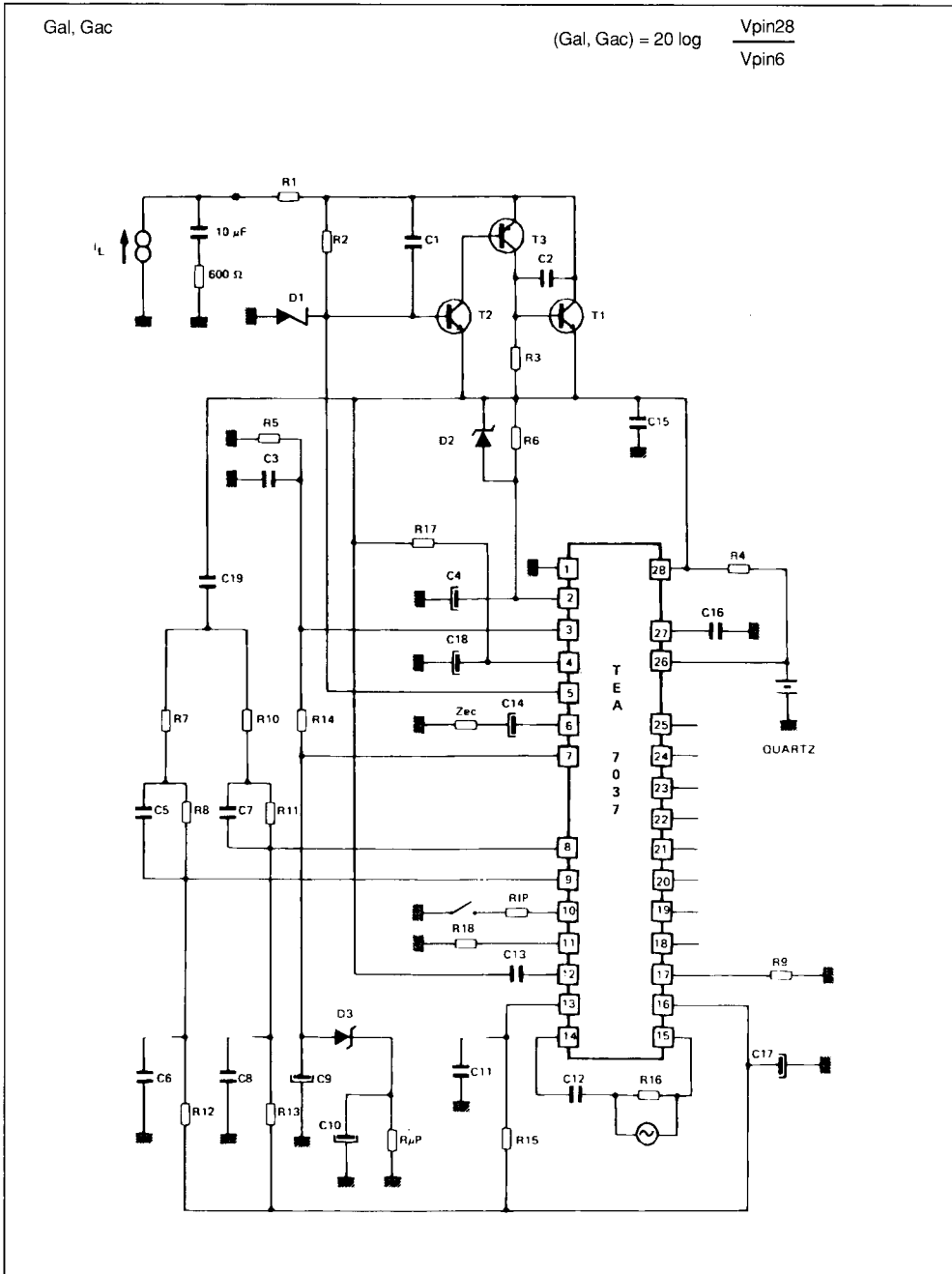


Figure 15 .

Zac

$$Zac = RL1 \times RL2 \frac{VL2 - VL1}{VL1 \times RL2 - VL2 \times RL1}$$

VL1 for RL1 = 300Ω

VL2 for RL2 = 600Ω

$$Zac = 600 \times \frac{VL2 - VL1}{2VL1 - VL2}$$

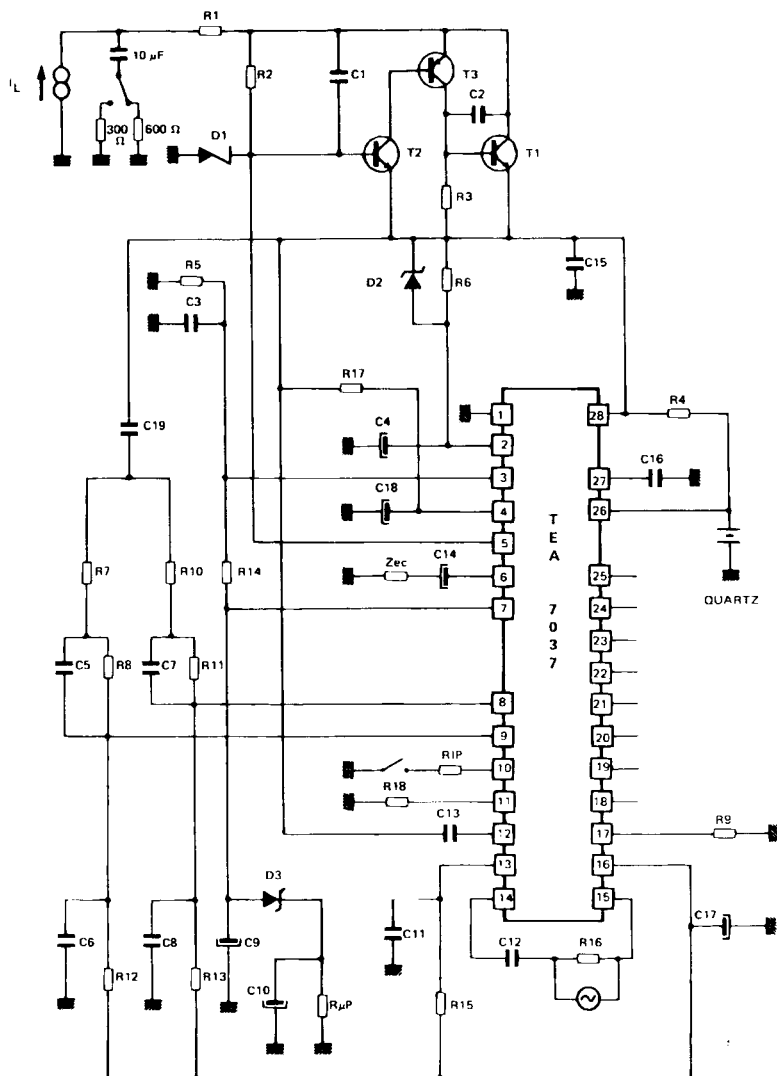


Figure 16 .

Nfb, Nfh, Pfv, Cfv,

697Hz + 1 209Hz
 Level and preemphasis are measured
 on pin 28

$$Cfv = 20 \log \frac{V_{pin28}}{V_{pin6}}$$

