

M61510AFP

Sound Controller for Quality/Sound Field Control, with Built-in Surround Sound

REJ03F0013-0100Z

Rev.1.00

Aug.07.2003

Description

The M61510AFP is a digital sound controller IC which is ideal for home audio applications. M61510AFP includes five-input selector, input volume control, surround sound (effect switchable in three stages), tone control (3 bands), loudness, and two-channel master volume control, all controllable via serial data. The M61510AFP can be interfaced with external circuits even when using the internal surround sound. And a common data format (software-compatible) facilitates M61510AFP substitution.

Features

- Five-input selector
- Input volume control (2 dB steps/3 bits)
- Surround sound IC interface
- Internal surround function (ON/OFF, High/Mid/Low)
- Internal surround function (bass/mid/treble)
- Internal loudness function
- Main volume control (1 dB steps (0 to -80 dB, $-\infty$))
- Microcomputer interface

Recommended Operating Conditions

- Power supply voltage range: $V_{CC} = 4.5$ to 5.5 V
- Rated power supply voltage: $V_{CC} = 5$ V

System Block Diagram

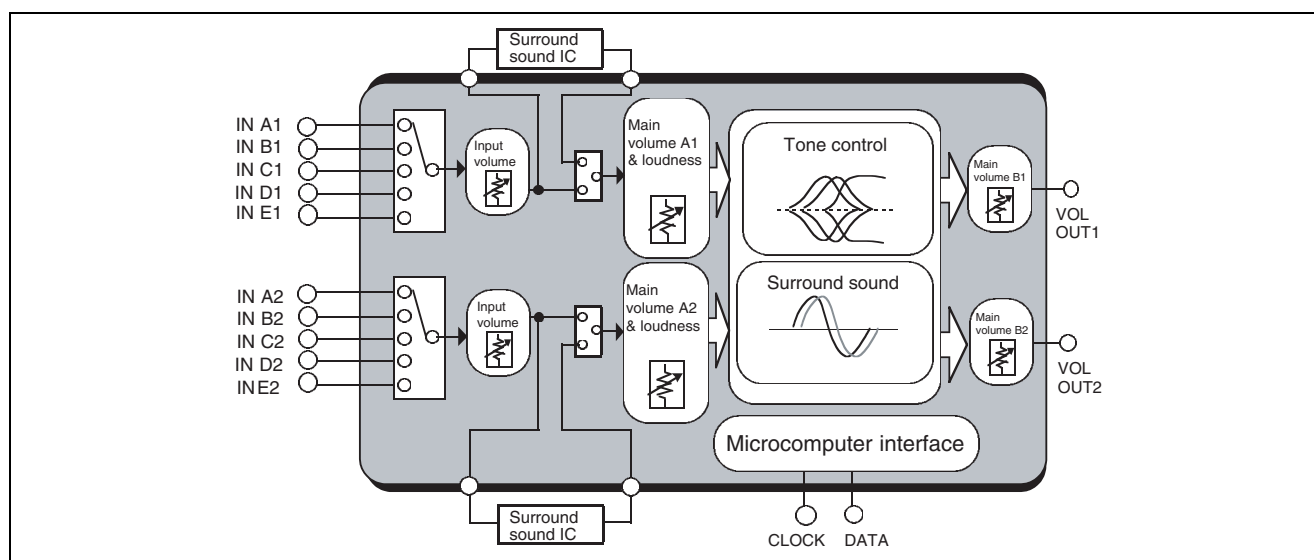

Block Diagram and Pin Arrangement

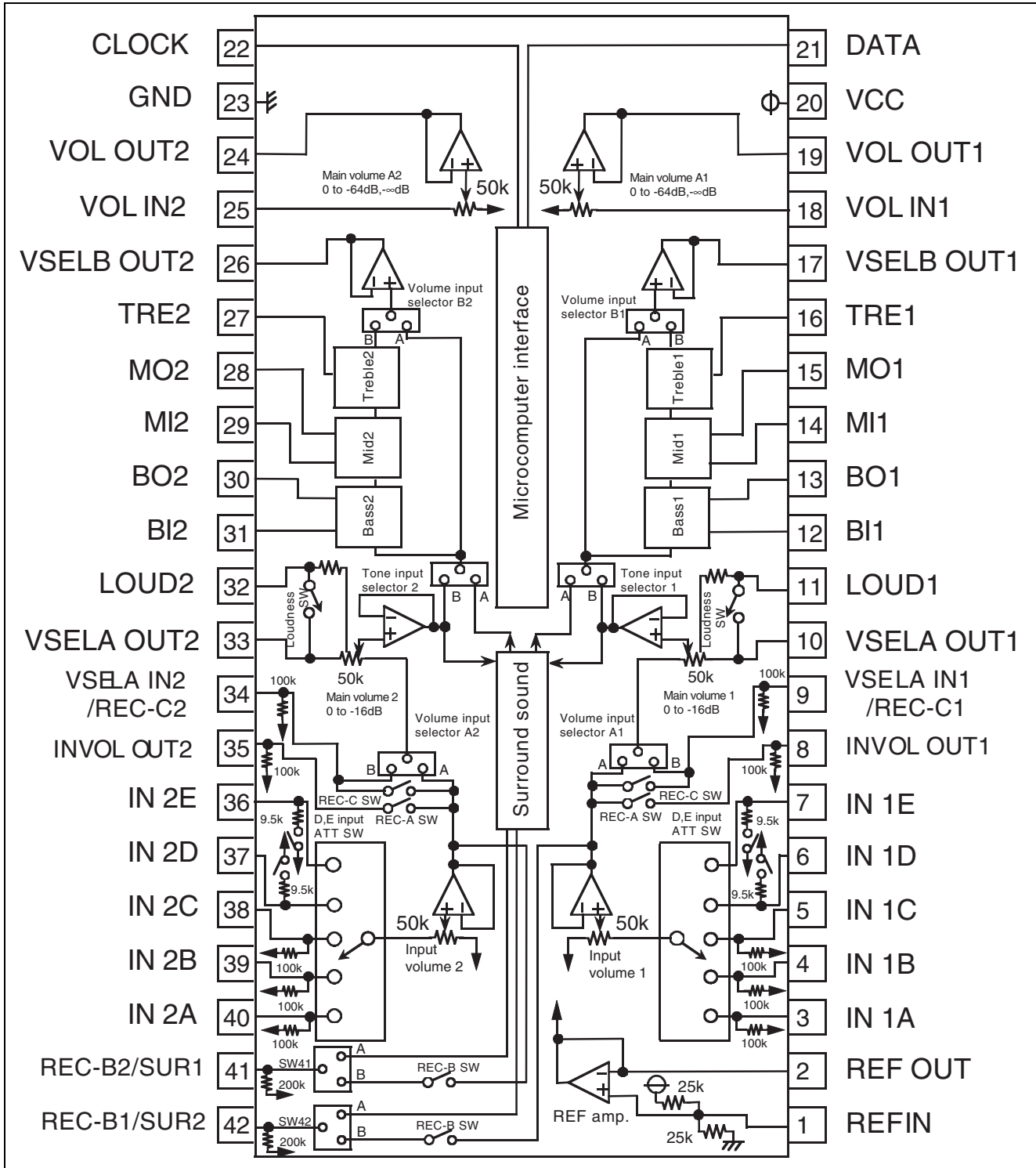

Pin Description

Pin No.	Pin Name	Function
1	REF IN	Reference amp input pin
2	REF OUT	Reference amp output pin
3, 4, 5, 6, 7, 36, 37, 38, 39, 40	IN 1A, 1B, 1C, 1D, 1E, 2A, 2B, 2C, 2D, 2E	Ch 1, 2 input selector input pins
8, 35	INVOL ONT1, 2	Input volume 1,2 output pins
9, 34	VSELA IN1, 2/REC-C1, 2	Volume input selector A1, 2 input/REC-C1, 2 output pins
10, 33	VSELA OUT1, 2	Volume switching noise reduction capacitor connection pins
11, 32	LOUD1, 2	Loudness circuitry frequency characteristic setting pins
12, 31	BI1, 2	Tone (bass) frequency characteristic setting pins
13, 30	BO1, 2	
14, 29	MI1, 2	Tone (mid) frequency characteristic setting pins
15, 28	MO1, 2	
16, 27	TRE1, 2	Tone (treble) frequency characteristic setting pins
17, 26	VSELB OUT1, 2	Volume input selector B1, 2 output pins
18, 25	VOL IN1, 2	Volume input pins
19, 24	VOL OUT1, 2	Volume output pins
20	VCC	Power supply
21	DATA	Serial data input pin
22	CLOCK	Clock input pin for serial data transfer
23	GND	GND
41	REC-B2/SUR1	REC-B2 output/surround external device connection pin
42	REC-B1/SUR2	REC-B1 output/surround external device connection pin

Absolute Maximum Ratings

Symbol	Item	Conditions	Rating	Unit
VCC	Power supply voltage		6.0	V
Pd	Internal power consumption	Ta ≤ 25°C	960	mW
K	Thermal reduction rate	Ta > 25°C	9.6	mW/°C
Topr	Operating temperature range		-20~+75	°C
Tstg	Storage temperature		-40~+125	°C

Thermal Reduction Curve

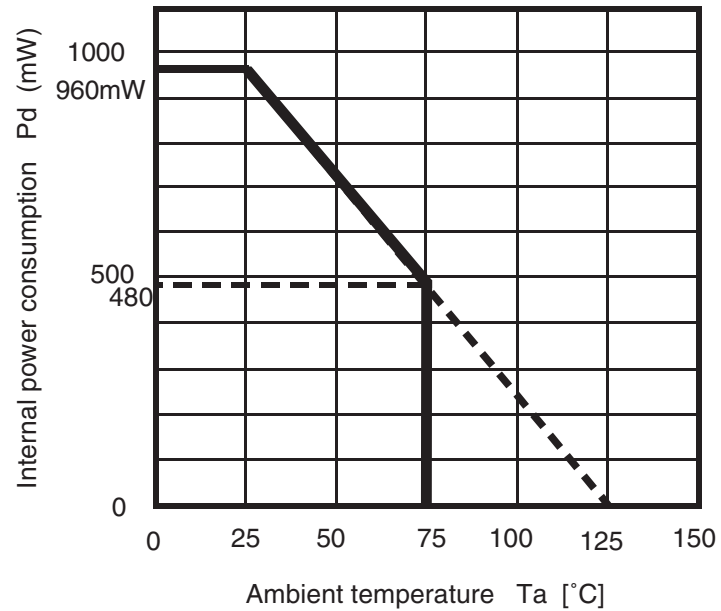

Recommended Operating Conditions

(Unless otherwise specified, Ta=25°C)

Item	Symbol	Condition	MIN	TYP	MAX	Units
Power supply voltage	VCC		4.5	5.0	5.5	V
Logic "H" level input voltage	VIH	GND reference	2.4	—	VCC	V
Logic "L" level input voltage	VIL	GND reference	GND	—	0.7	V

Relation of Data and Clock

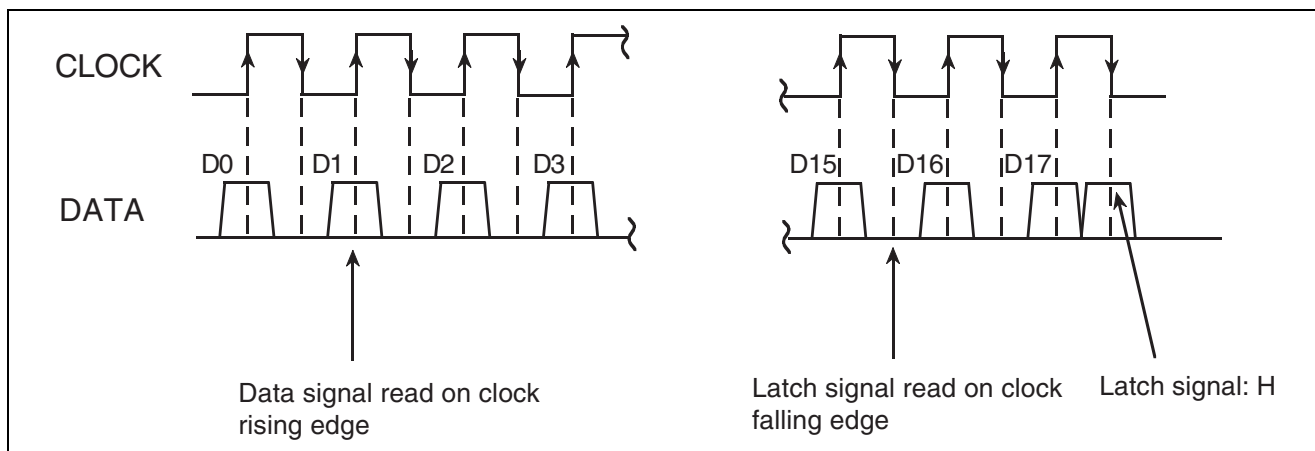

Data Input Format

(Data other than the following settings should not be sent)

By changing the D14 and D15 slot setting states, any of four input formats can be selected.

(However, each time the power is turned on, after sending the following MUTE release data, initial settings should be made for the data of all four formats.)

MUTE release data (X indicates any setting)

D0d D1d D2d D3d D4d D5d D6d D7d D8d D9d D10d D11d D12d D13d D14 D15 D16 D17
 X X X 0 X 1 X X X X X X X 1 1 0 0

Chip address

(1)

D0a	D1a	D2a	D3a	D4a	D5a	D6a	D7a	D8a	D9a	D10a	D11a	D12a	D13a	D14	D15	D16	D17
Tone control treble				Tone control mid				Tone control bass				Vocal cut	0	0	0	0	0

(2)

D0b	D1b	D2b	D3b	D4b	D5b	D6b	D7b	D8b	D9b	D10b	D11b	D12b	D13b	D14	D15	D16	D17
First-stage main volume CH1				Second-stage main volume CH1								D input ATT SW	E input ATT SW	0	1	0	0

(3)

D0c	D1c	D2c	D3c	D4c	D5c	D6c	D7c	D8c	D9c	D10c	D11c	D12c	D13c	D14	D15	D16	D17
First-stage main volume CH2				Second-stage main volume CH2								Tone input selector	D/E input ATTSW -5/-8 dB	1	0	0	0

(4)

	D0d	D1d	D2d	D3d	D4d	D5d	D6d	D7d	D8d	D9d	D10d	D11d	D12d	D13d	D14	D15	D16	D17	
Note 1) Using external surround	Input selector			Note 2) Mute	REC-B ON : 1 OFF : 0	1	Input volume					Volume input selector A	0	1	1	0	0		
Note 1) Using internal surround [1]				Surround	0	REC-C ON : 1 OFF : 0						Volume input selector B						REC-A ON : 1 OFF : 0	Loudness switch
Note 3) Using internal surround [2]						0						0						1	

Note 1) Using external surround ("D5d=1", "D13d=0") → SW41, 42 settings fixed at B, REC-C SW fixed at OFF
 Using internal surround [1] ("D5d=0", "D13d=0") → SW41, 42 settings fixed at A, REC-B SW fixed at OFF,
 volume input selector A setting fixed at A.

Note 2) The following settings are used to mute the output pin at power-on.
 Input selector = ALL OFF, external surround mode setting, REC-A to C SW=OFF, second-stage main volume =∞
 (and, when D14=D15=1 and D16=D17=0, by setting D3d=D5d=1, mute can be similarly set)

It is the same as that of M61510FP

Note 3) This function is added in the M61510AFP

When using internal surround [2] ("D5d=0", "D13d=1") → SW41, 42 fixed at A,
 REC-B/C SW fixed at OFF, volume input selector A setting fixed at B

*Regarding [1]/[2] when using internal surround

*Using internal surround [1] (same function as in existing model M61510FP)

In this mode only the internal surround function is used, and external circuitry is not used.

*Using internal surround [2] (function unique to M61510AFP, added to this IC)

In this mode the internal surround function is used, and in addition an external circuit is connected and used.

(However, because REC-C is fixed at OFF, use as the REC output is not possible.)

Setting Codes

(Data other than the following settings should not be sent)

(1) Tone control (treble/mid/bass)

ATT amount	Treble	D0a	D1a	D2a	D3a
	Mid	D4a	D5a	D6a	D7a
	Bass	D8a	D9a	DAa	DBa
+ 8dB	1	1	0	0	
+ 6dB	1	0	1	1	
+ 4dB	1	0	1	0	
+ 2dB	1	0	0	1	
0dB	0	0	0	0	
- 2 dB	0	0	0	1	
- 4 dB	0	0	1	0	
- 6 dB	0	0	1	1	
- 8 dB	0	1	0	0	

(9) Input selector

INPUT	D0d	D1d	D2d
A ch	0	0	0
B ch	0	0	1
C ch	0	1	0
D ch	0	1	1
E ch	1	0	0
ALL OFF	1	1	1

(2) Loudness

Loudness	D12d
OFF	0
ON	1

(3) Volume input selector A

*Controllable only when D5d=1

Volume input selector A setting	D9d
Bypass	0
External surround input	1

(10) REC-A,B,C switch

*REC-B controllable only when D5d = 1
REC-C controllable only when D5d = 0 and D13d = 0

Data	D11d	D4d	D9d
REC output	A	B	C
0	OFF		
1	ON		

(4) Volume input selector B

Volume input selector B setting	D10d
Bypass	0
Tone	1

(5) Tone input selector

Tone input selector setting	D12c
Bypass	0
Internal surround input	1

(11) Surround

*Controllable only when D5d = 0

Surround setting	D3d	D4d
OFF	0	0
L	1	0
M	0	1
H	1	1

(6) E input ATT switch

E input ATT switch	D13b
0dB	0
-5/-8 dB	1

(7) D input ATT switch

D input ATT switch	D12b
0dB	0
-5/-8 dB	1

(12) Input volume

Input volume setting	D6d	D7d	D8d
0 dB	0	0	0
-2 dB	0	0	1
-4 dB	0	1	0
-6 dB	0	1	1
-8 dB	1	0	0
-10 dB	1	0	1
-12 dB	1	1	0
-14 dB	1	1	1

(13) D/E input ATT amount switch

D/E input ATT switch(*1)	D13c
-8 dB	0
-5 dB	1

(8) Vocal cut switch

Vocal cut switch	D12a
OFF	0
ON	1

(*1) ATT amount when an Rin = 12 kΩ input resistance is connected to the D/E input pin

(14) First-stage main volume

ATT amount	First stage volume CH1	D0b	D1b	D2b	D3b	D4b
	First stage volume CH2	D0c	D1c	D2c	D3c	D4c
	0dB	0	0	0	0	0
	-1dB	0	0	0	0	1
	-2dB	0	0	0	1	0
	-3dB	0	0	0	1	1
	-4dB	0	0	1	0	0
	-5dB	0	0	1	0	1
	-6dB	0	0	1	1	0
	-7dB	0	0	1	1	1
	-8dB	0	1	0	0	0
	-9dB	0	1	0	0	1
	-10dB	0	1	0	1	0
	-11dB	0	1	0	1	1
	-12dB	0	1	1	0	0
	-13dB	0	1	1	0	1
	-14dB	0	1	1	1	0
	-15dB	0	1	1	1	1
	-16dB	1	0	0	0	0

(15) Second-stage main volume

ATT amount	Second stage volume CH1	D5b	D6b	D7b	D8b	D9b	D10b	D11b
	Second stage volume CH2	D5c	D6c	D7c	D8c	D9c	D10c	D11c
0dB		0	0	0	0	0	0	0
-1dB		0	0	0	0	0	0	1
-2dB		0	0	0	0	0	1	0
-3dB		0	0	0	0	0	1	1
-4dB		0	0	0	0	1	0	0
-5dB		0	0	0	0	1	0	1
-6dB		0	0	0	0	1	1	0
-7dB		0	0	0	0	1	1	1
-8dB		0	0	0	1	0	0	0
-9dB		0	0	0	1	0	0	1
-10dB		0	0	0	1	0	1	0
-11dB		0	0	0	1	0	1	1
-12dB		0	0	0	1	1	0	0
-13dB		0	0	0	1	1	0	1
-14dB		0	0	0	1	1	1	0
-15dB		0	0	0	1	1	1	1
-16dB		0	0	1	0	0	0	0
-17dB		0	0	1	0	0	0	1
-18dB		0	0	1	0	0	1	0
-19dB		0	0	1	0	0	1	1
-20dB		0	0	1	0	1	0	0
-21dB		0	0	1	0	1	0	1
-22dB		0	0	1	0	1	1	0
-23dB		0	0	1	0	1	1	1
-24dB		0	0	1	1	0	0	0
-25dB		0	0	1	1	0	0	1
-26dB		0	0	1	1	0	1	0
-27dB		0	0	1	1	0	1	1
-28dB		0	0	1	1	1	0	0
-29dB		0	0	1	1	1	0	1
-30dB		0	0	1	1	1	1	0
-31dB		0	0	1	1	1	1	1

ATT amount	Second stage volume CH1	D5b	D6b	D7b	D8b	D9b	D10b	D11b
	Second stage volume CH2	D5c	D6c	D7c	D8c	D9c	D10c	D11c
-32dB		0	1	0	0	0	0	0
-33dB		0	1	0	0	0	0	1
-34dB		0	1	0	0	0	1	0
-35dB		0	1	0	0	0	1	1
-36dB		0	1	0	0	1	0	0
-37dB		0	1	0	0	1	0	1
-38dB		0	1	0	0	1	1	0
-39dB		0	1	0	0	1	1	1
-40dB		0	1	0	1	0	0	0
-41dB		0	1	0	1	0	0	1
-42dB		0	1	0	1	0	1	0
-43dB		0	1	0	1	0	1	1
-44dB		0	1	0	1	1	0	0
-45dB		0	1	0	1	1	0	1
-46dB		0	1	0	1	1	1	0
-47dB		0	1	0	1	1	1	1
-48dB		0	1	1	0	0	0	0
-49dB		0	1	1	0	0	0	1
-50dB		0	1	1	0	0	1	0
-51dB		0	1	1	0	0	1	1
-52dB		0	1	1	0	1	0	0
-53dB		0	1	1	0	1	0	1
-54dB		0	1	1	0	1	1	0
-55dB		0	1	1	0	1	1	1
-56dB		0	1	1	1	0	0	0
-57dB		0	1	1	1	0	0	1
-58dB		0	1	1	1	0	1	0
-59dB		0	1	1	1	0	1	1
-60dB		0	1	1	1	1	0	0
-61dB		0	1	1	1	1	0	1
-62dB		0	1	1	1	1	1	0
-63dB		0	1	1	1	1	1	1
-64dB		1	0	0	0	0	0	0
-∞dB		1	0	0	0	0	0	1

Electrical Characteristics

(Unless otherwise specified, $T_a = 25^\circ\text{C}$, $V_{CC} = 5.0\text{ V}$, $f = 1\text{ kHz}$, the input main volume = 0 dB, surround and loudness are OFF, the volume input selector A, B settings =BYPASS, and tone input selector =BYPASS; see the application circuit example)

(1) Power supply characteristics

Item	Symbol	Conditions	Ratings			Unit
			MIN	TYP	MAX	
Circuit current	Aldd	No signal	—	35	60	mA

(2) I/O characteristics (total)

Item	Symbol	Conditions	Ratings			Unit
			Min	typ	Max	
Input resistance	Rin	3~5 pin, 38~40 pin	22	33	48	k Ω
Maximum input voltage	VIMt	(input to pins 3-5, 38-40) pin 19, 24 output, first stage main volume setting =-2 dB RL = 10 k Ω , THD = 1%	1.2	1.4	—	Vrms
	VIMtDE	(pin 6, 7, 36, 37 input) pin 19, 24 output Note) Input resistance =12 k Ω , RL = 10 k Ω , THD = 1% D, E ch ATT switch = -8 dB setting, input VOL=-2 dB setting	2.8	4.4	—	Vrms
Maximum output voltage	VOMt	(pin 3, 40 input) pin 19, 24 output, RL = 10 k Ω , THD = 1%	1.0	1.25	—	Vrms
Pass gain	Gvt	Gain across (pins 3-6, 37-40)-pins 19, 24, Vi=0.5 Vrms, FLAT	-2.0	0	2.0	dB
Total harmonic distortion	THDA	(pin 3, 40 input) pin 19, 24 output, DIN-AUDIO, Vi=0.5 Vrms, RL = 30 k Ω ,	—	0.006	0.07	%
	THDB	Volume input selector B settings THDA: bypass, THDB: tone	—	0.009	0.09	%
Output noise voltage	NoA	pin 19, 24, Rg = 0 Ω , JIS-A Main volume setting =- ∞	—	2.5	6	μVrms
		pin 19, 24, Rg = 0 Ω , JIS-A Main volume setting = 0 dB	—	5	10	μVrms
	NoB	pin 19, 24, Rg = 0 Ω , JIS-A Volume input selector B: tone	—	7	15	μVrms
		pin 19, 24, Rg = 0 Ω , JIS-A Volume input selector B: tone, tone input selector: surround	—	10	20	μVrms
Crosstalk between channels	CT	Vo = 0.5 Vrms, RL = 10 k Ω , JIS-A, Across pins 19-24, Rg = 0 Ω ,	—	-80	-65	dB
Maximum volume attenuation	ATTmax	Vi = 1 Vrms, JIS-A, Main volume setting =- ∞	—	—	-80	dB

Note: The 12 k Ω input resistance should be inserted in series with the pin.

(3) Tone control characteristics

(Unless otherwise specified, $V_i=0.2$ Vrms, 9.34 PIN input, 17.26 PIN output, volume input selector A: external surround input, tone input selector: BYPASS, volume input selector B: TONE).

Item	Symbol	Conditions	Ratings			Unit
			Min	typ	Max	
Boost amount (bass)	G(BASS)B	f = 100 Hz Tone base set to +8 dB	6	8	10	dB
Cut amount (bass)	G(BASS)C	f = 100 Hz Tone base set to -8 dB	-10	-8	-6	dB
Boost amount (mid)	G(MID)B	f = 1 kHz Tone mid set to +8 dB	6	8	10	dB
Cut amount (mid)	G(MID)B	f = 1 kHz Tone mid set to -8 dB	-10	-8	-6	dB
Boost amount (treble)	G(TRE)B	f = 10 kHz Tone treble set to +8 dB	6	8	10	dB
Cut amount (treble)	G(TRE)B	f = 10 kHz Tone treble set to -8 dB	-10	-8	-6	dB
Channel balance	BALT	When each boost amount is +8, -8 dB	-2	0	+2	dB

Explanation of Functions

(1) Main volume

This IC includes two independent low-distortion, low-noise electronic volume systems. The attenuation can be set from 0 dB to $-\infty$ dB in 1 dB steps.

Also, the attenuation can be set between 0 and -16 dB for the first stage, and between 0 and -64 dB for the second stage, and both can be controlled independently.

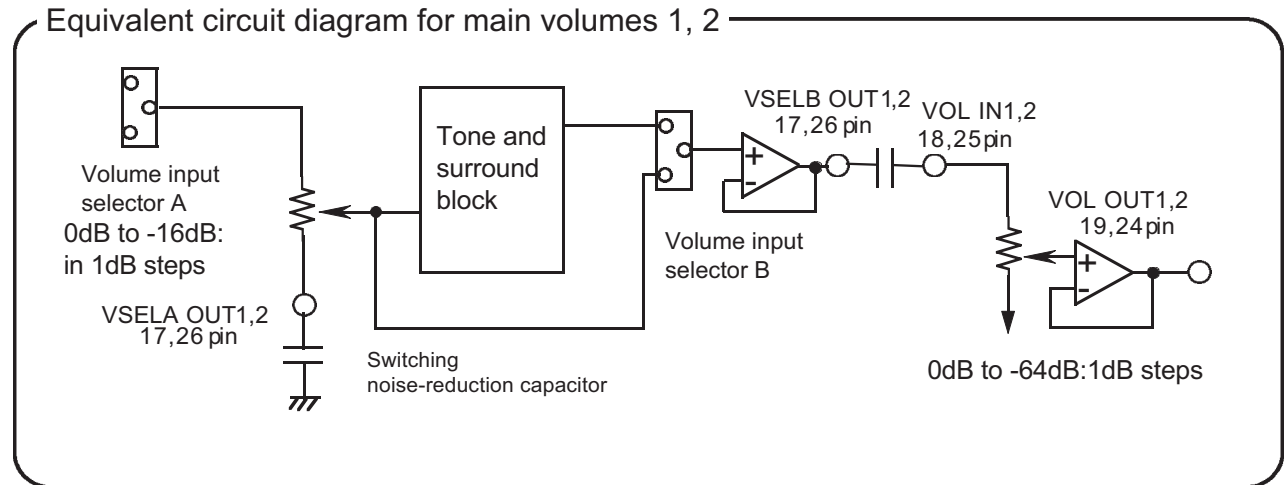

(2) Input selector, input volume

Two channels of 5-input selectors, and two channels of input volume controls for input trimmers, are incorporated. The D and E inputs of the input selectors can select either 0 dB or -8 dB input levels for an input resistance of 12 k Ω using the ATT switch. The input volume can be set between 0 and -14 dB in 2 dB steps.

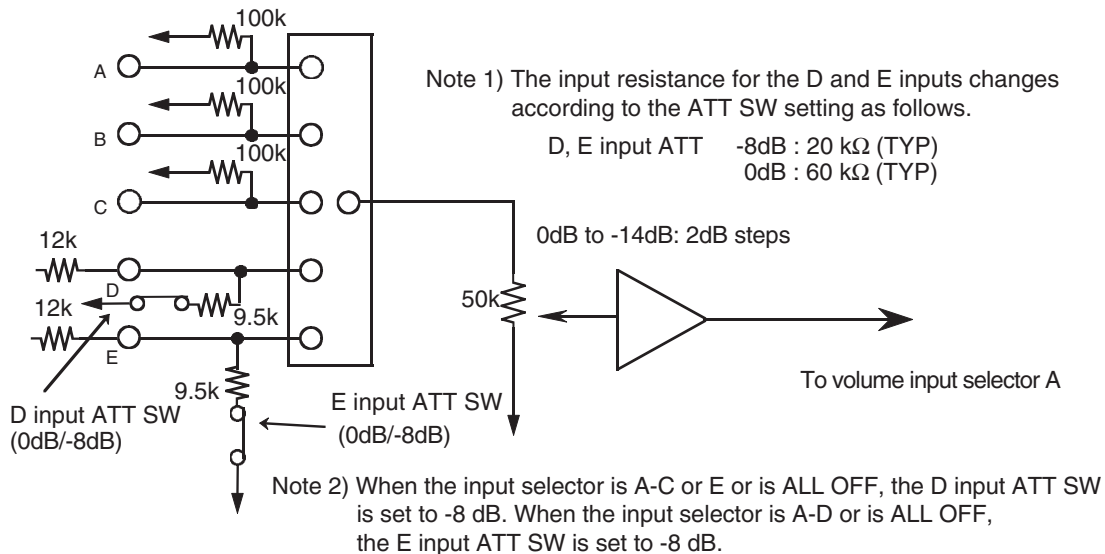

Note 3) The D and E input ATT amounts shown are the values when a D and E input resistance $R_{in}=12\text{ k}\Omega$ is connected.

Note 4) When the external 12 k Ω resistance is eliminated, the D and E input ATT amounts are set as follows.

ATT Setting	Input Resistance (TYP)
0dB	1.87dB
-8dB	0dB

(3) Tone control equivalent circuit

3-1 Bass, mid (boost mode)

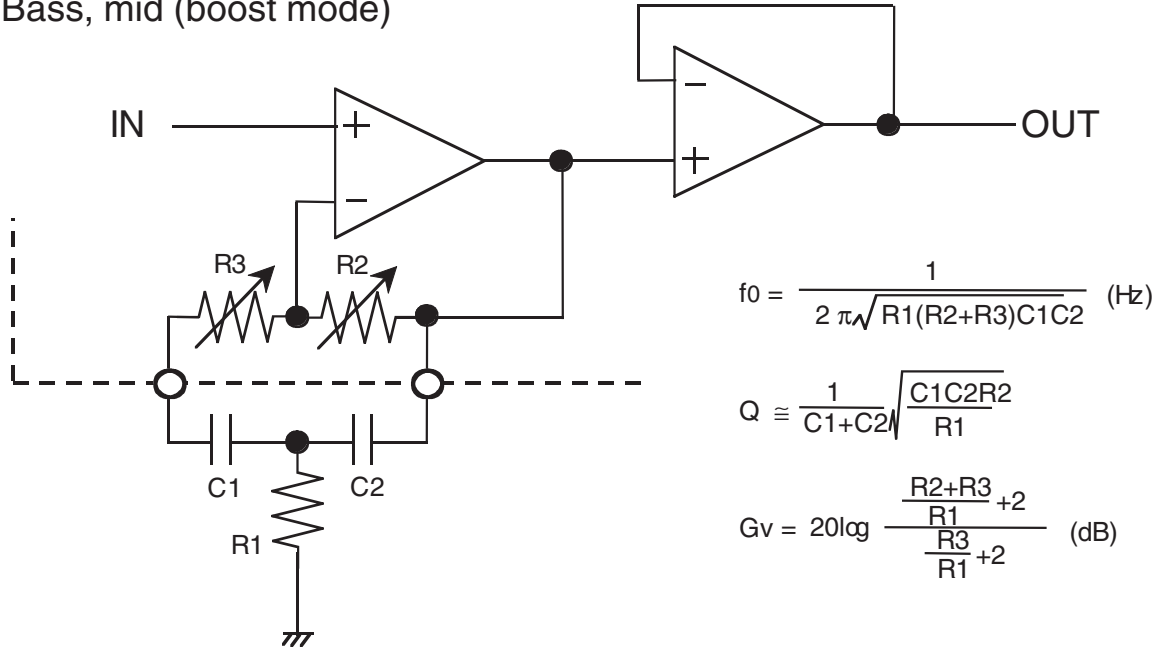

3-2 Bass, mid (cut mode)

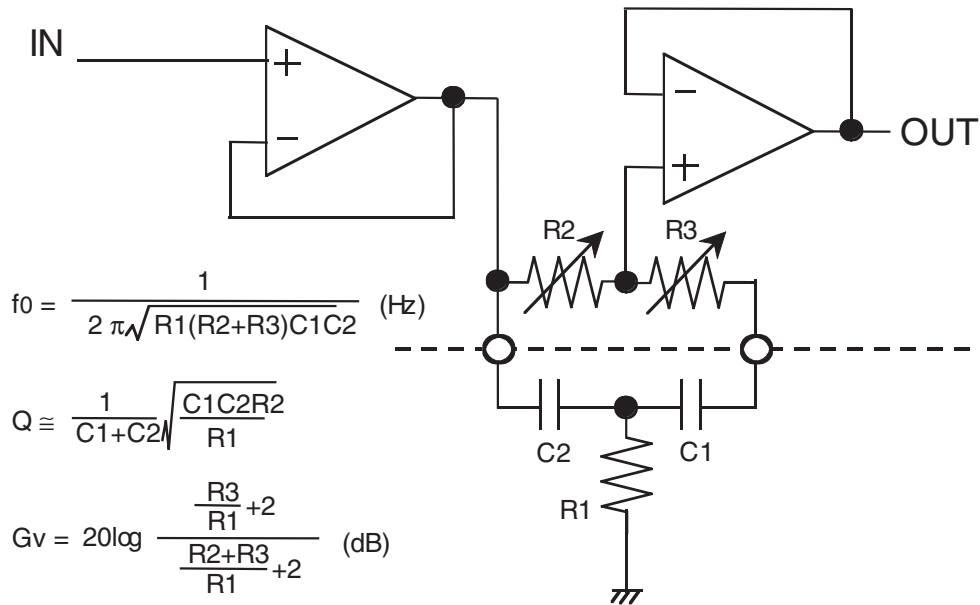

*Internal resistance values (units: Ω)

<Boost>

Setting	R2	R3
+2dB	10.6k	27.3k
+4dB	19.1k	18.8k
+6dB	25.8k	12.1k
+8dB	31.1k	6.8k

<Cut>

Setting	R2	R3
+2dB	10.6k	27.3k
+4dB	19.1k	18.8k
+6dB	25.8k	12.1k
+8dB	31.1k	6.8k

3-3 Treble (boost)

$$G_v = 20 \log \frac{R_1 + R_2}{R_1} \text{ (dB)}$$

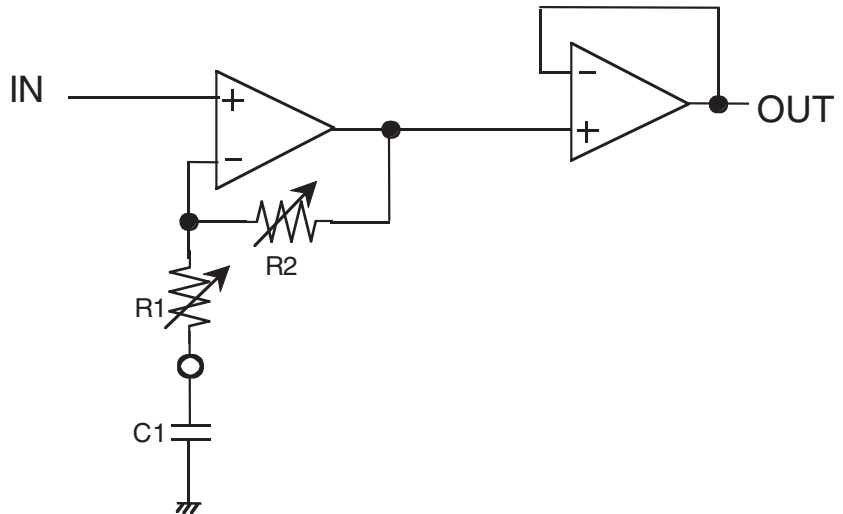

3-4 Treble (cut)

$$G_v = 20 \log \frac{R_1}{R_1 + R_2} \text{ (dB)}$$

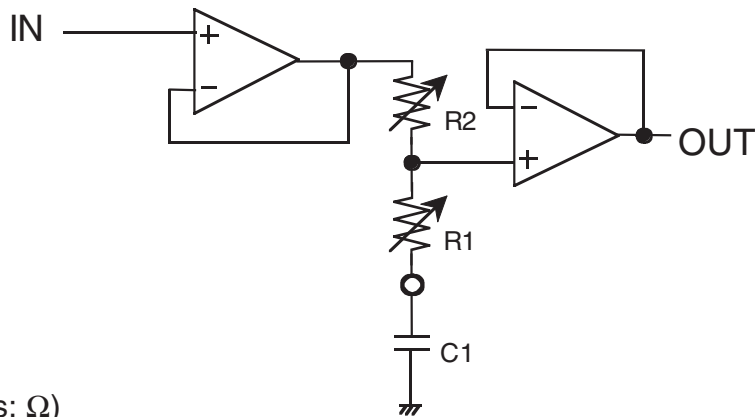

*Internal resistance values (units: Ω)

<Boost>

Setting	R1	R2
+2dB	16.0k	4.4k
+4dB	12.6k	7.8k
+6dB	9.7k	10.7k
+8dB	7.1k	13.3k

<Cut>

Setting	R1	R2
-2dB	16.0k	4.4k
-4dB	12.6k	7.8k
-6dB	9.7k	10.7k
-8dB	7.1k	13.3k

<Characteristic curves>

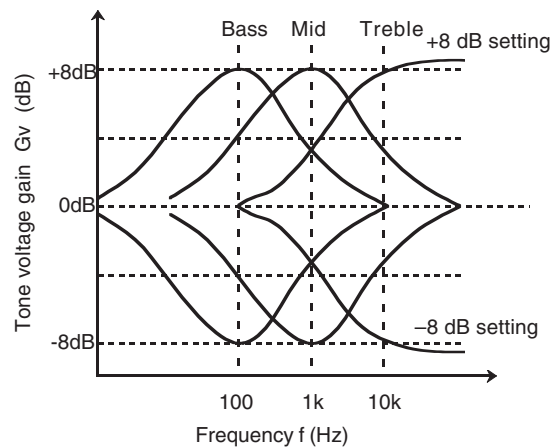

(4) Vocal cut equivalent circuit diagram

This IC incorporates a circuit which uses a tone control midrange circuit to lower the midrange gain, to easily realize a vocal cut function.

However, when the vocal cut function is on, the tone control midrange cannot be used.

Vocal cut switch

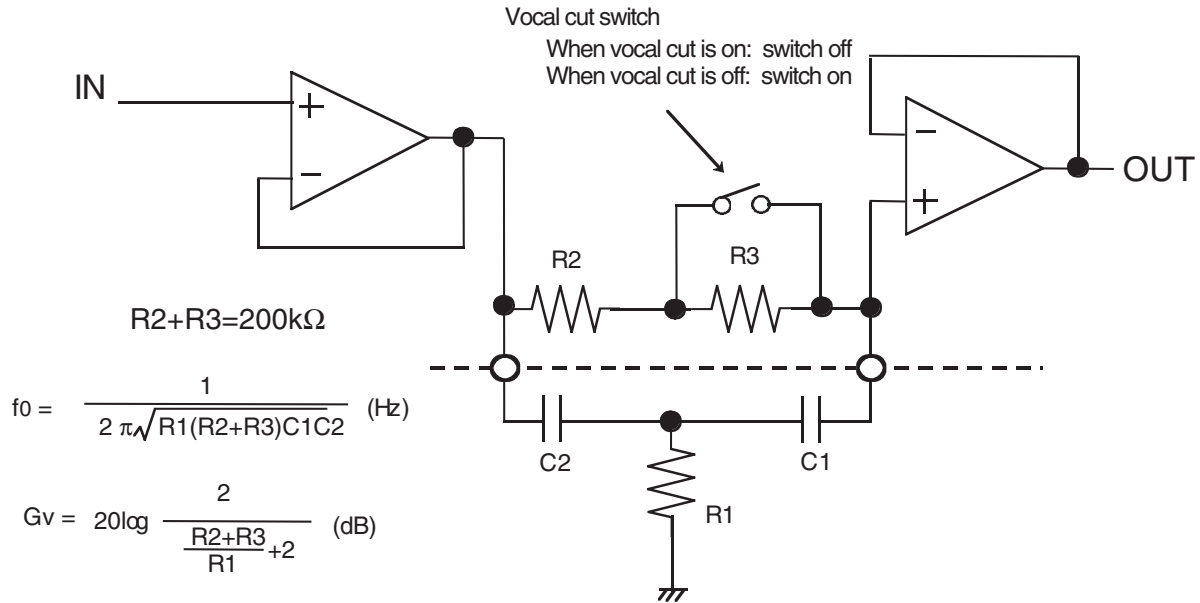

External resistances: The frequency characteristics when vocal cut is on can be set as shown below through the constants R1, C1, and C2.

<Characteristic curves>

1. Emphasis on vocal cut characteristic $f_0=550\text{Hz}$
 $R=3\text{k}\Omega$ $C_1=C_2=0.012\mu\text{F}$ $G_v=-30\text{dB}$

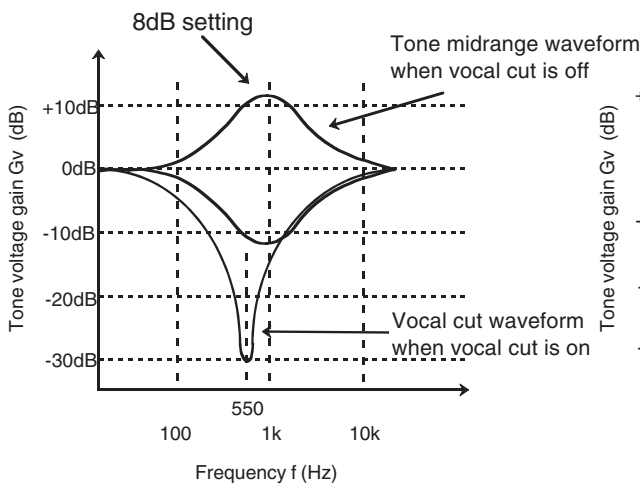

2. Emphasis on tone control mid characteristic $f_0=530\text{Hz}$
 $R=10\text{k}\Omega$, $C_1=C_2=6800\text{pF}$ $G_v=-20\text{dB}$

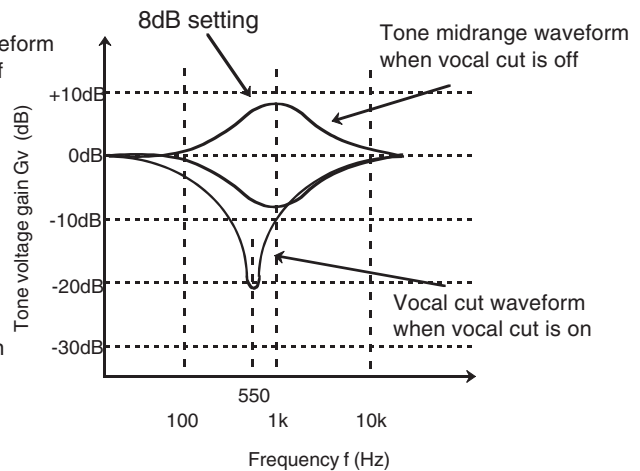

(5) Loudness

This IC incorporates a center-tap loudness circuit.

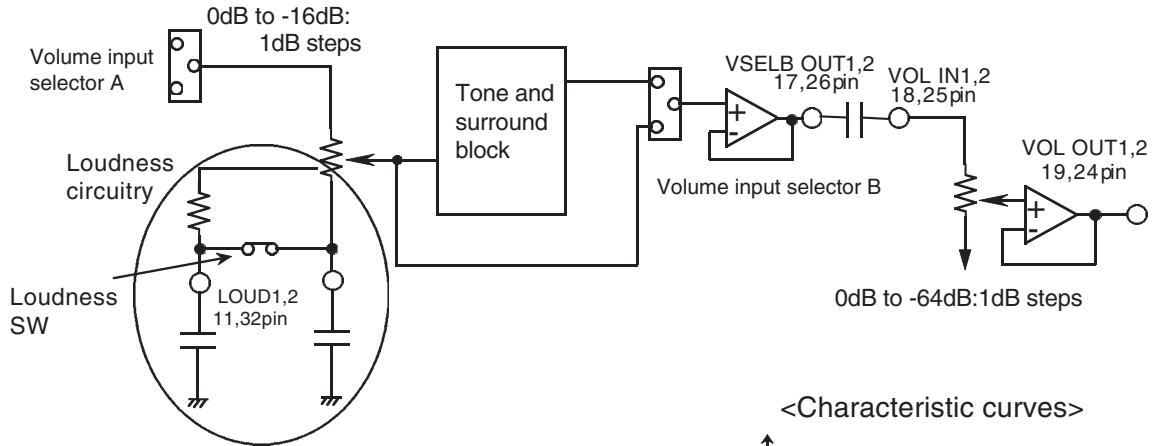

The loudness circuitry f_o is determined by the 50 kΩ internal resistance and the external capacitor C, represented by the following equation.

$$f_o = 1 / (2\pi \times 50k\Omega \times C) \text{ Hz}$$

When $C = 0.1 \mu\text{F}$,

$$f_o = 1 / (2\pi \times 50k\Omega \times 0.1\mu\text{F}) = 32 \text{ Hz}$$

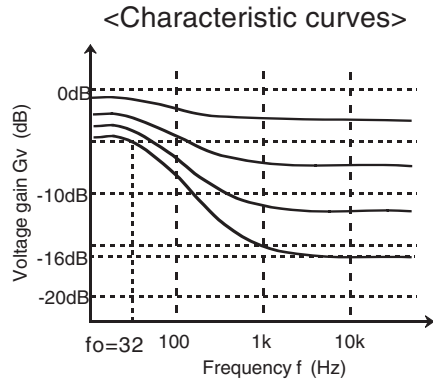

(6) Equivalent circuit with surround on

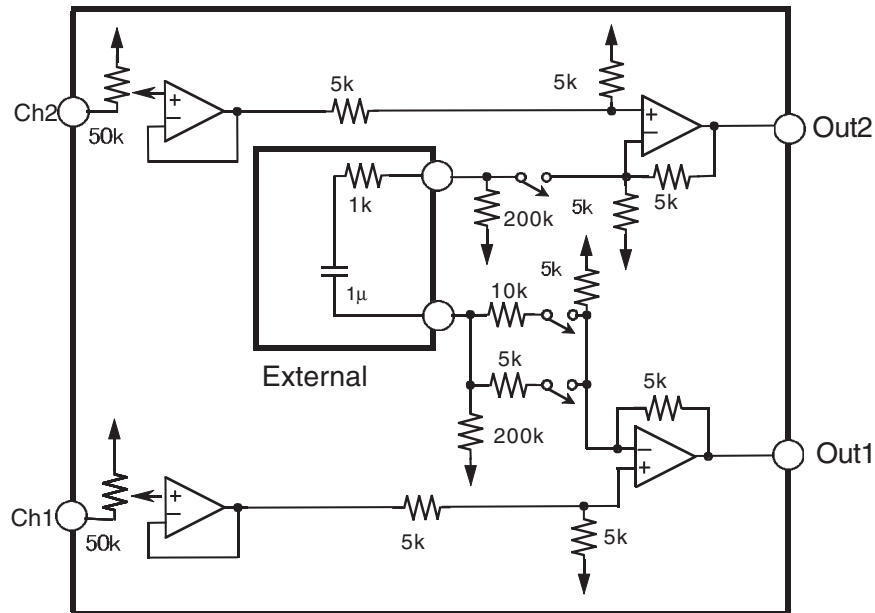

(7) IC internal configuration

(7-1) Using external surround (surround IC)

<"D5d=1" → SW41, 42 fixed at B, REC-C SW fixed to OFF>

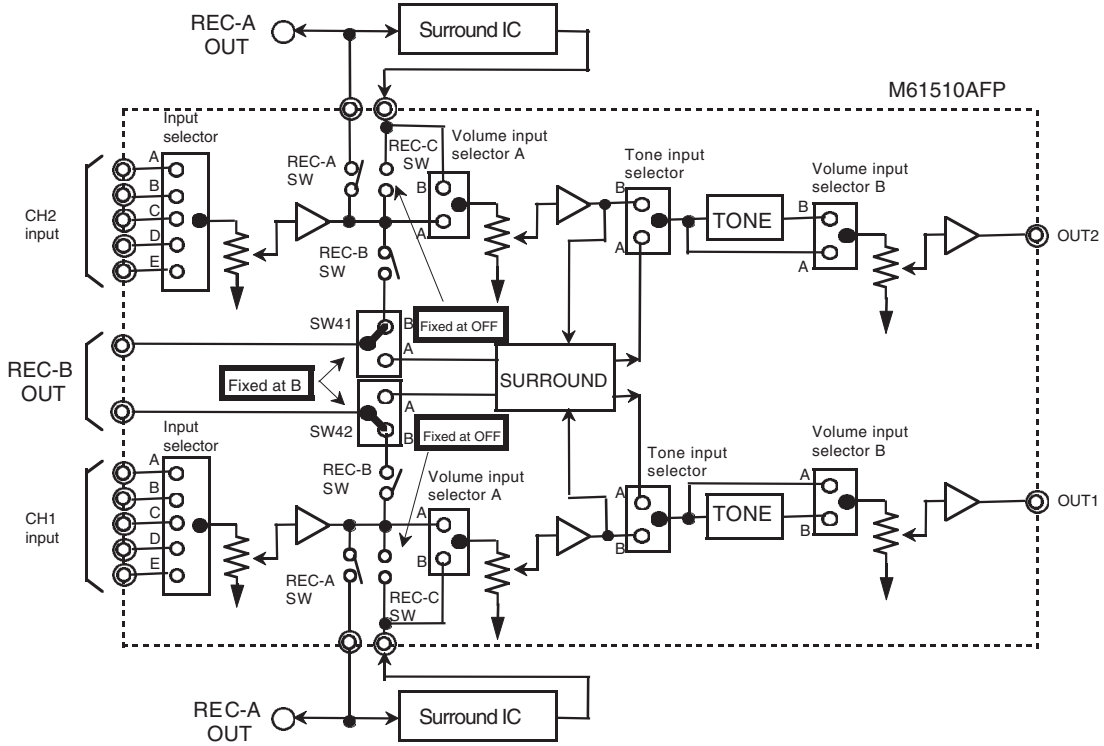

(7-2) Using internal surround [1]

<"D5d=0", "D13d=0" → Volume input selector A fixed at A, SW41, 42 fixed at A, REC-B SW fixed to OFF>

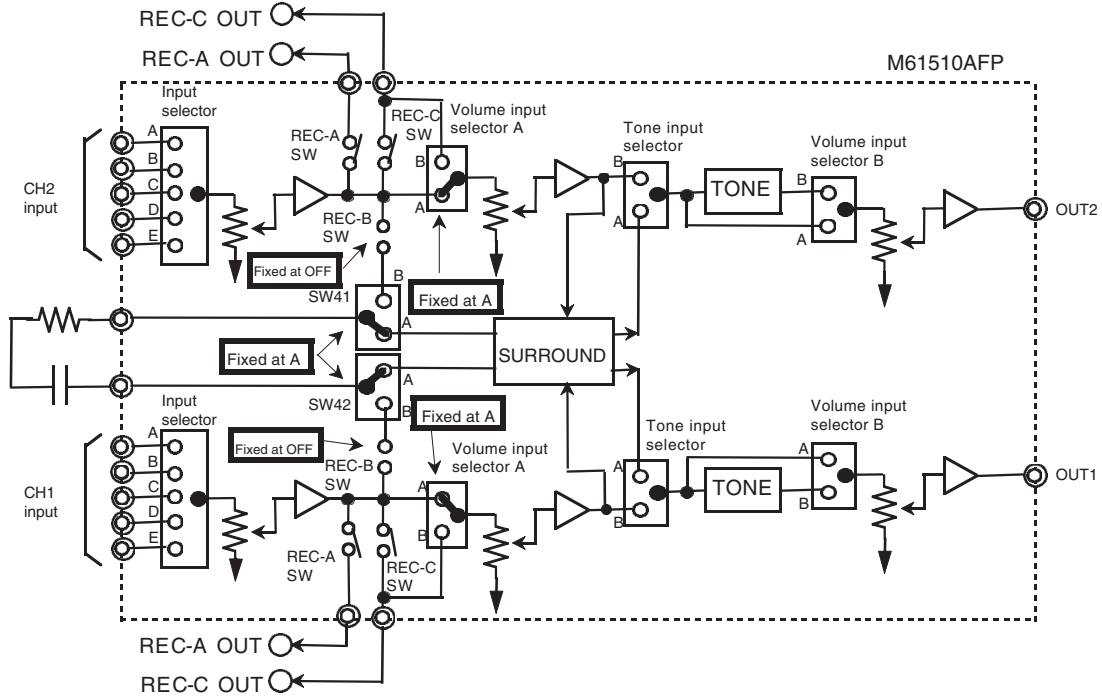

(7-2) Using internal surround [2]

<"D5d=0", "D13d=1" → Volume input selector A fixed at B, SW41, 42 fixed at A, REC-B/C SW fixed to OFF>

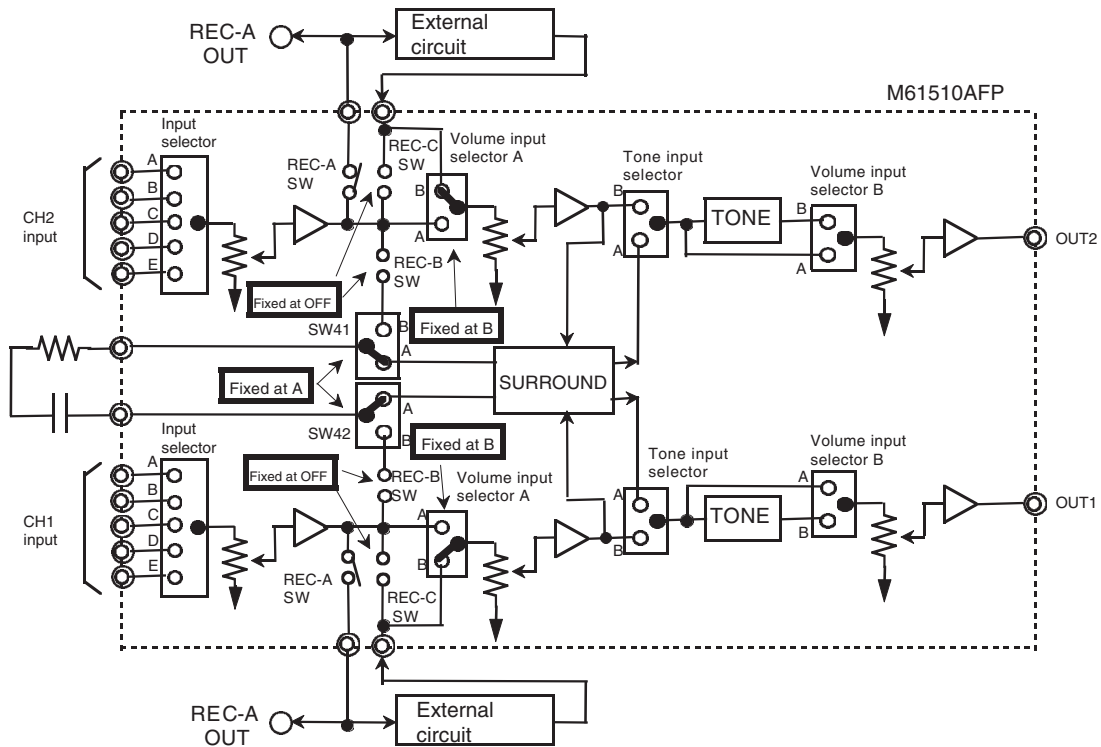

Application Circuit Example

(1) Using external surround (surround IC) ("D5d=1" → SW41, 42 fixed at B)

However, with these specifications, internal surround cannot be used.

Units Resistance : Ω
Capacitance : F

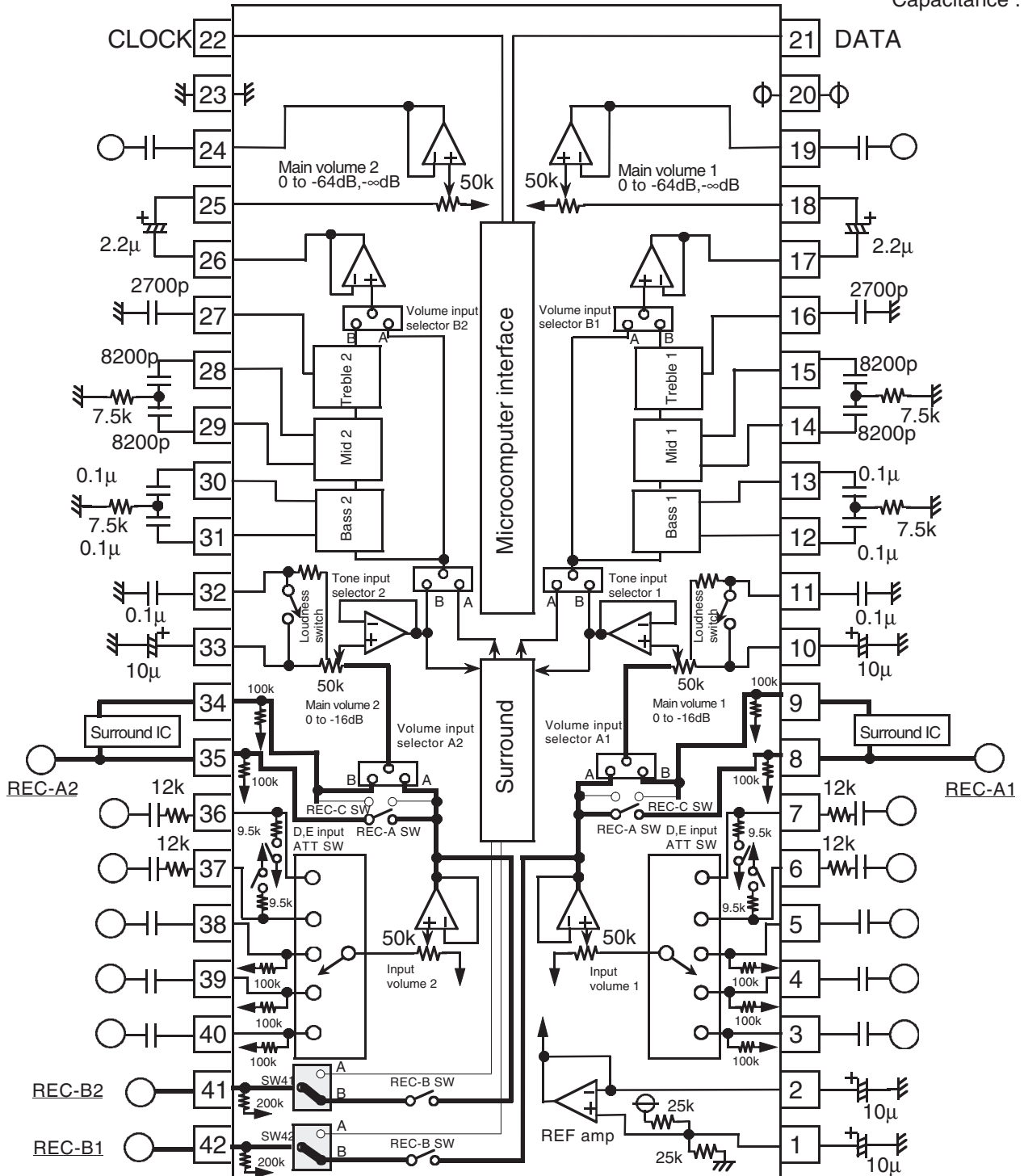

(2) Using internal surround [1]

<"D5d=0", "D13d=0" → SW41, 42 fixed at A, volume input selector A fixed at A>

Units Resistance : Ω
Capacitance : F

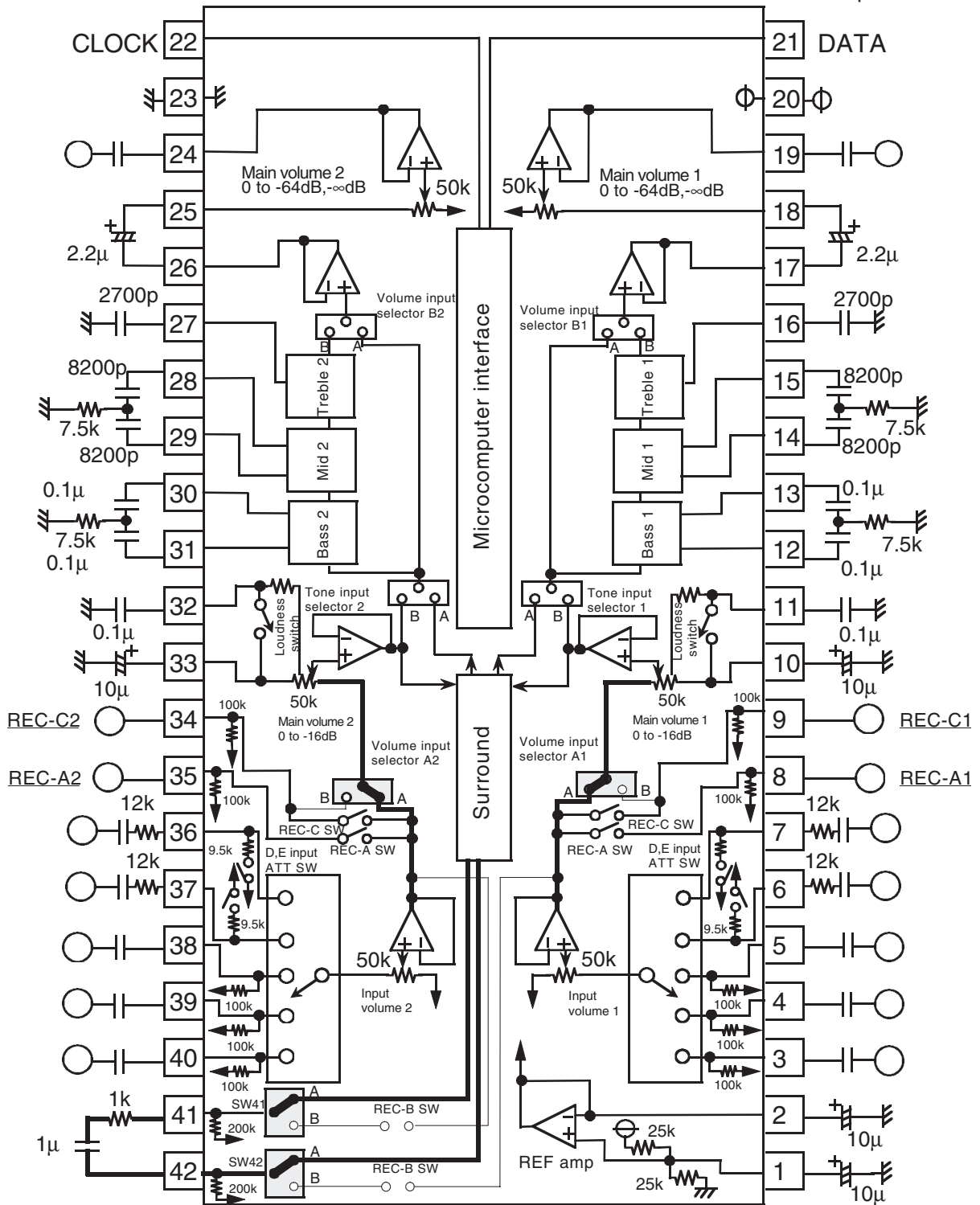

(2) Using internal surround [2] (also using external circuit)

<"D5d=0", "D13d=1" → SW41, 42 fixed at A, REC-C switch fixed at OFF, volume input selector A fixed at B>

Units Resistance: Ω
Capacitance: F

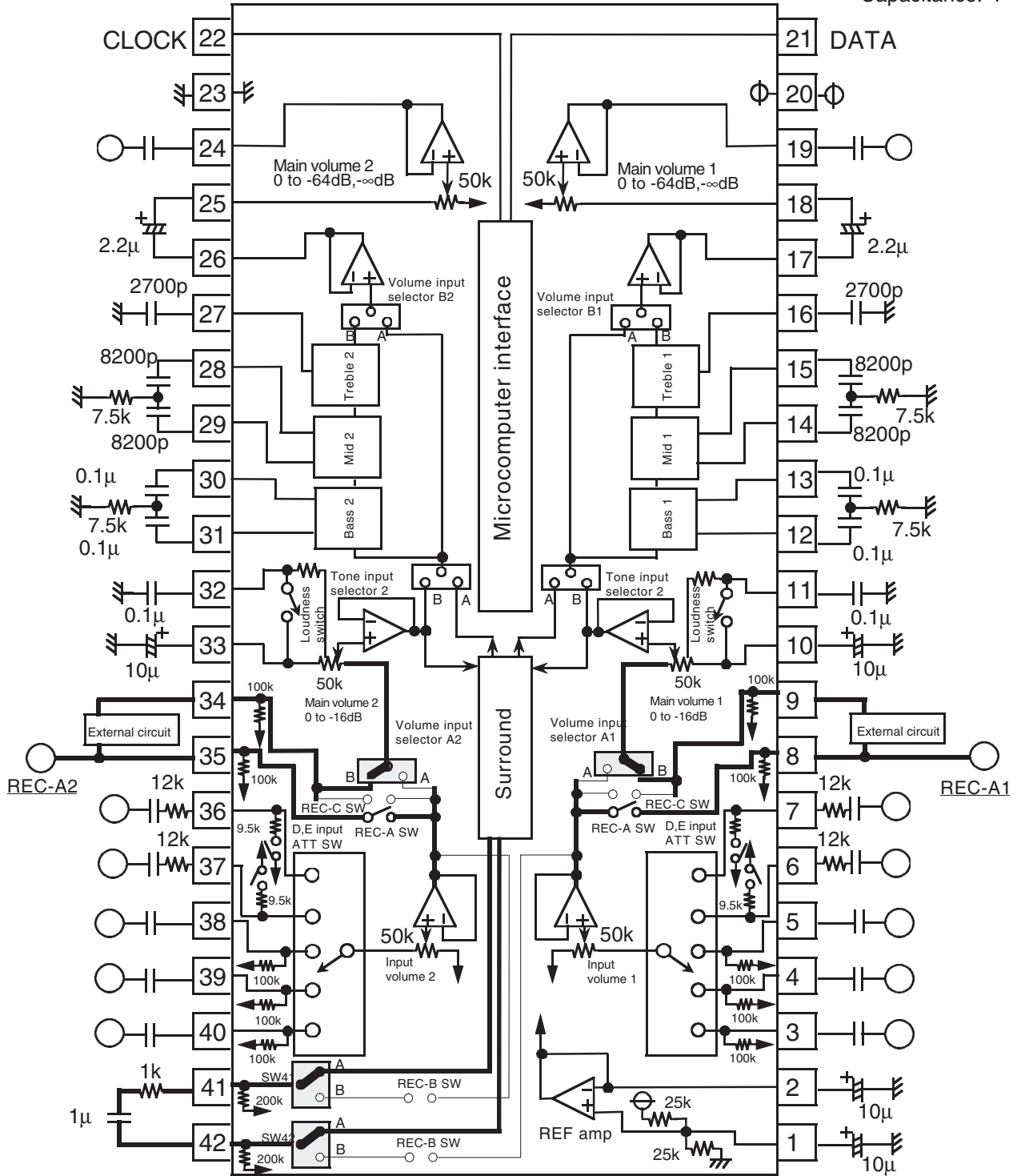

Package Dimensions

42P2R-E

MMP

Plastic 42pin 450mil SSOP

EIAJ Package Code SSOP42-P-450-0.80	JEDEC Code —	Weight(g) —	Lead Material Cu Alloy+42 Alloy
--	-----------------	----------------	------------------------------------

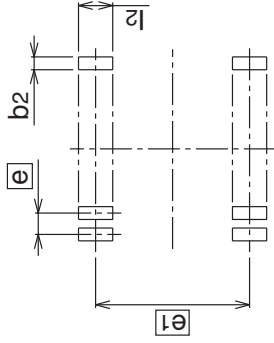
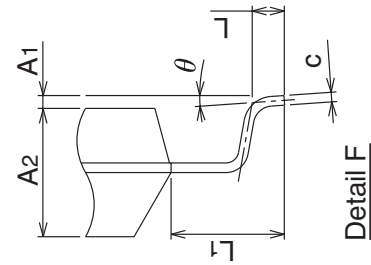
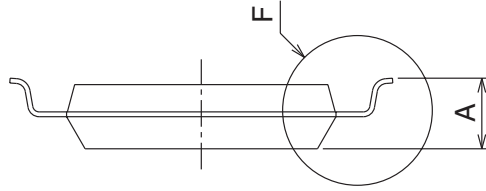
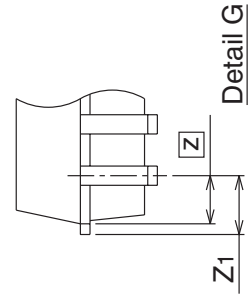
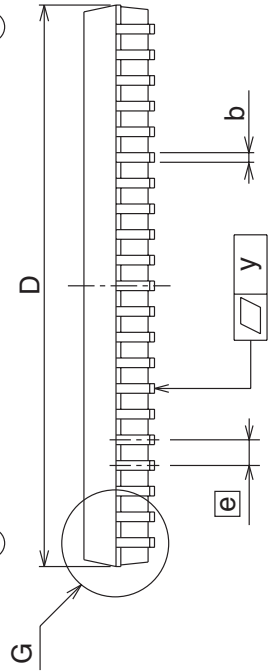
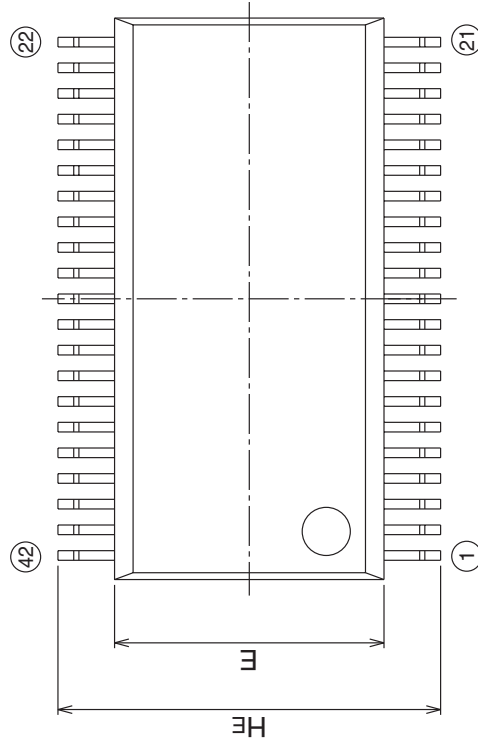

Recommended Mount Pad

Symbol	Dimension in Millimeters		
	Min	Norm	Max
A	—	—	2.4
A1	0.05	—	—
A2	—	2.0	—
b	0.25	0.3	0.4
c	0.13	0.15	0.2
D	17.3	17.5	17.7
E	8.2	8.4	8.6
e	—	0.8	—
HE	11.63	11.93	12.23
L	0.3	0.5	0.7
L1	—	1.765	—
Z	—	0.75	—
Z1	—	—	0.9
y	—	—	0.15
theta	0°	—	10°
b2	—	0.5	—
e1	—	11.43	—
l2	1.27	—	—

RENESAS Technology Corp. Sales Strategic Planning Div. Nippon Bldg., 2-6-2, Ohte-machi, Chiyoda-ku, Tokyo 100-0004, Japan

Keep safety first in your circuit designs!

1. Renesas Technology Corp. puts the maximum effort into making semiconductor products better and more reliable, but there is always the possibility that trouble may occur with them. Trouble with semiconductors may lead to personal injury, fire or property damage.
Remember to give due consideration to safety when making your circuit designs, with appropriate measures such as (i) placement of substitutive, auxiliary circuits, (ii) use of nonflammable material or (iii) prevention against any malfunction or mishap.

Notes regarding these materials

1. These materials are intended as a reference to assist our customers in the selection of the Renesas Technology Corp. product best suited to the customer's application; they do not convey any license under any intellectual property rights, or any other rights, belonging to Renesas Technology Corp. or a third party.
 2. Renesas Technology Corp. assumes no responsibility for any damage, or infringement of any third-party's rights, originating in the use of any product data, diagrams, charts, programs, algorithms, or circuit application examples contained in these materials.
 3. All information contained in these materials, including product data, diagrams, charts, programs and algorithms represents information on products at the time of publication of these materials, and are subject to change by Renesas Technology Corp. without notice due to product improvements or other reasons. It is therefore recommended that customers contact Renesas Technology Corp. or an authorized Renesas Technology Corp. product distributor for the latest product information before purchasing a product listed herein.
The information described here may contain technical inaccuracies or typographical errors.
Renesas Technology Corp. assumes no responsibility for any damage, liability, or other loss rising from these inaccuracies or errors.
Please also pay attention to information published by Renesas Technology Corp. by various means, including the Renesas Technology Corp. Semiconductor home page (<http://www.renesas.com>).
 4. When using any or all of the information contained in these materials, including product data, diagrams, charts, programs, and algorithms, please be sure to evaluate all information as a total system before making a final decision on the applicability of the information and products. Renesas Technology Corp. assumes no responsibility for any damage, liability or other loss resulting from the information contained herein.
 5. Renesas Technology Corp. semiconductors are not designed or manufactured for use in a device or system that is used under circumstances in which human life is potentially at stake. Please contact Renesas Technology Corp. or an authorized Renesas Technology Corp. product distributor when considering the use of a product contained herein for any specific purposes, such as apparatus or systems for transportation, vehicular, medical, aerospace, nuclear, or undersea repeater use.
 6. The prior written approval of Renesas Technology Corp. is necessary to reprint or reproduce in whole or in part these materials.
 7. If these products or technologies are subject to the Japanese export control restrictions, they must be exported under a license from the Japanese government and cannot be imported into a country other than the approved destination.
Any diversion or reexport contrary to the export control laws and regulations of Japan and/or the country of destination is prohibited.
 8. Please contact Renesas Technology Corp. for further details on these materials or the products contained therein.
-



RENESAS SALES OFFICES

<http://www.renesas.com>

Renesas Technology America, Inc.
450 Holger Way, San Jose, CA 95134-1368, U.S.A
Tel: <1> (408) 382-7500 Fax: <1> (408) 382-7501

Renesas Technology Europe Limited.
Dukes Meadow, Millboard Road, Bourne End, Buckinghamshire, SL8 5FH, United Kingdom
Tel: <44> (1628) 585 100, Fax: <44> (1628) 585 900

Renesas Technology Europe GmbH
Dornacher Str. 3, D-85622 Feldkirchen, Germany
Tel: <49> (89) 380 70 0, Fax: <49> (89) 929 30 11

Renesas Technology Hong Kong Ltd.
7/F., North Tower, World Finance Centre, Harbour City, Canton Road, Hong Kong
Tel: <852> 2265-6688, Fax: <852> 2375-6836

Renesas Technology Taiwan Co., Ltd.
FL 10, #99, Fu-Hsing N. Rd., Taipei, Taiwan
Tel: <886> (2) 2715-2888, Fax: <886> (2) 2713-2999

Renesas Technology (Shanghai) Co., Ltd.
26/F., Ruijin Building, No.205 Maoming Road (S), Shanghai 200020, China
Tel: <86> (21) 6472-1001, Fax: <86> (21) 6415-2952

Renesas Technology Singapore Pte. Ltd.
1, Harbour Front Avenue, #06-10, Keppel Bay Tower, Singapore 098632
Tel: <65> 6213-0200, Fax: <65> 6278-8001