

---

**THREE PHASE POWER/ENERGY METERING MODULE  
PULSE OUTPUT**

---

**FEATURES**

- Performs one, two or three phase power and energy measurement
- Meets the accuracy requirements for Class 1 AC Watt hour meters
- Operates over a wide Temperature Range
- Uses current transformers for current sensing
- Three pulse rate outputs available
- Protected against ESD

**DESCRIPTION**

The SAMES three phase power/energy metering module, the PM9105AF provides three pulse rate output options, the frequency of which are proportional to the active power consumption.

Energy consumption can be determined by the power measurement being integrated over time.

The method of calculation takes the power factor into account.

The output of this innovative universal three phase power/energy metering circuit is ideally suited for energy calculations in applications using a  $\mu$ -controller or mechanical counter.

The application utilises the SAMES SA9105AF, SA9105EF or SA9105FF three phase power metering integrated circuits for power measurement.

**BLOCK DIAGRAM**

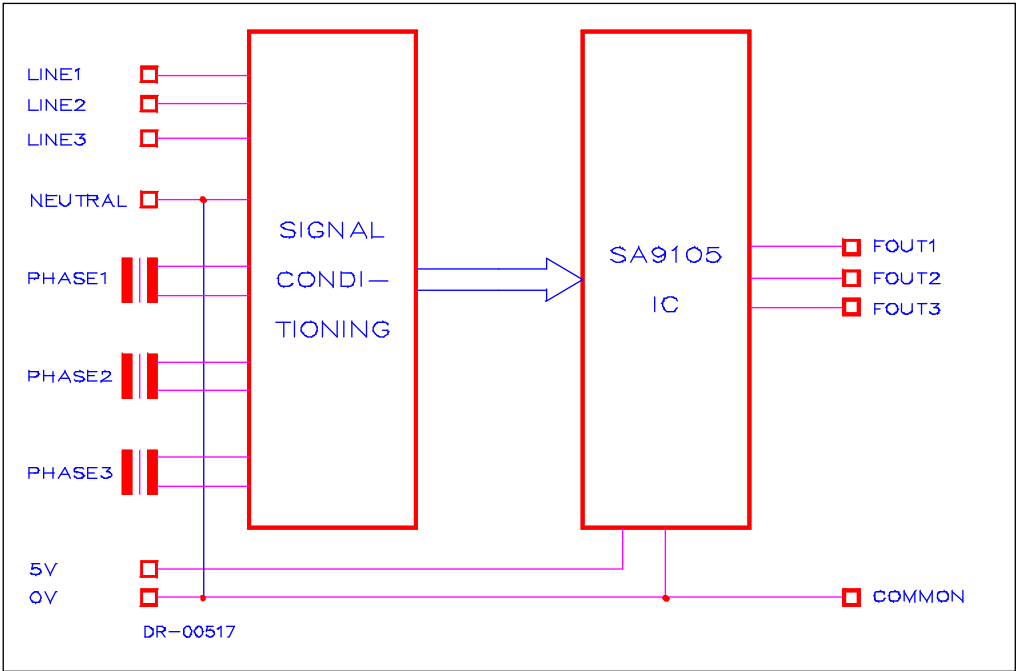

**ABSOLUTE MAXIMUM RATINGS \***

Parameter	Symbol	Min	Max	Unit
Supply Voltage (Note 1)	$V_{AC}$		540	V
Storage Temperature	$T_{STG}$	-25	+125	°C
Operating Temperature (Note 2)	$T_o$	-10	+70	°C

Note 1: Voltages are specified with reference to Neutral.

Note 2: The SA9105 integrated circuit is specified to operate over the temperature range -10°C to +70°C. The module functionality will however depend upon the external components used.

\* Stresses above those listed under "Absolute Maximum Ratings" may cause permanent damage to the device. This is a stress rating only. Functional operation of the device at these or any other conditions above those indicated in the operation sections of this specification, is not implied. Exposure to Absolute Maximum Ratings for extended periods may affect device reliability.

## ELECTRICAL CHARACTERISTICS

(Over the temperature range  $-10^{\circ}\text{C}$  to  $+70^{\circ}\text{C}$ , unless otherwise specified. Power consumption figures are applicable to the PM9105AFE only.)

Parameter	Symbol	Min	Typ	Max	Unit	Condition
Supply Voltage (x3 Phases) (Continuous)	$V_{AC}$	180 90	230 115	265 138	V V	PM9105AFE PM9105AFA
Frequency Output	FOUTX	Refer to applicable IC data sheet				
Power Consumption <sup>1</sup>				100	mW	$V_{DD} = 5\text{V}$

Note 1: Power consumption specifications exclude power consumed by the current sensors.

## CONNECTION DESCRIPTION

Designation	Description
PL5	Voltage Supply connected to Phase 1 Voltage Supply connected to Phase 2 Voltage Supply connected to Phase 3 Voltage Supply connected to Neutral Line (Common)
PL6	Power Output: 4Hz at rated current Power Output: 290 Hz at rated current Power Output: 1160 Hz at rated current 0V (Common)
PL4	5V DC Supply Voltage 0V DC Supply Voltage
CT1	Phase 1 (Direction indicated on PCB)
CT2	Phase 2 (Direction indicated on PCB)
CT3	Phase 3 (Direction indicated on PCB)

## FUNCTIONAL DESCRIPTION

### 1. Power Calculation

In the Application Circuit (see Figure 2), the output currents from the current sensors will be between 0 and  $16\mu\text{A}$ . The current input stages saturate at input currents greater than  $18\mu\text{A}_{\text{RMS}}$ . The mains voltage (mains voltage + 15% - 20%) is used for the power calculation, together with the current information from the current sensors (current transformers).

The calculated power for the 3 phases is integrated over time and converted into a corresponding frequency.



For rated conditions, the signals into the current and voltage sensor inputs are set as follows:

Current sensor input currents:  $16\mu A_{RMS}$

Voltage sensor input currents:  $14\mu A_{RMS}$

Under these conditions, the device generates a pulse rate of 1,16kHz at output FOUT1.

The output frequency at FOUT2 is FOUT1/4. At FOUT3 the output frequency is FOUT1/290.

## **2. Electrostatic Discharge (ESD) Protection**

The device's inputs/outputs are protected against ESD according to Mil-Std 883C, method 3015. The modules resistance to transients will be dependant upon the protection components used.

## **3. Power Consumption**

The overall power consumption rating for this power metering application (Figure 2), is under 500mW, excluding the current sensors.

## **4. Isolation**

The reference for the unit is connected to neutral.

## **5. Circuit Description**

The module is supplied from an external 5V DC supply.

The Application Circuit (figure 2), details the components required for a three phase power metering module. Terminated current transformers are used as current sensors.

The most important external components are:

$C_7$ ,  $C_9$ ,  $C_{10}$  and  $C_{11}$  are the outer loop capacitors for the integrated oversampling A/D converters. The typical value of  $C_7$  is 2.2nF and the value of  $C_9$ ,  $C_{10}$  and  $C_{11}$  is 560pF.

The actual values determine the signal to noise and stability performance. The tolerances should be within  $\pm 10\%$ .

$C_4$ ,  $C_5$ ,  $C_6$  and  $C_8$  are the inner loop capacitors for the integrated oversampling A/D converters. The typical value of  $C_4$ ,  $C_5$ ,  $C_6$  and  $C_8$  is 3.3nF. Values smaller than 0.5nF and larger than 5nF should be avoided.

Terminated current sensors (current transformers) are connected to the current sensor inputs of the SA9105 through current setting resistors ( $R_8 \dots R_{13}$ ).

The resistor values should be selected for an input current of  $16\mu A$  into the SA9105 at the rated line current.

The values of these resistors should be calculated as follows:

Phase 1:

$$R_8 = R_9 = (I_{L1}/16\mu A) \times R_{18}/2$$

Phase 2:

$$R_{10} = R_{11} = (I_{L2}/16\mu A) \times R_{19}/2$$

Phase 3:

$$R_{12} = R_{13} = (I_{L3}/16\mu A) \times R_{20}/2$$

Where  $I_{LX}$  = Secondary CT current at rated conditions.

$R_{18}$ ,  $R_{19}$  and  $R_{20}$  = Termination resistors of the three current transformers.

$R_1 + R_{1A}$ ,  $R_4$  and  $R_{15}$  set the current for the phase 1 voltage sense input.  $R_2 + R_{2A}$ ,  $R_5 + P_5$  and  $R_{16}$  set the current for phase 2 and  $R_3 + R_{3A}$ ,  $R_6 + P_6$  and  $R_{17}$  set the current for Phase 3. The values should be selected so that the input currents into the voltage sense inputs (virtual ground) is set to  $14\mu A$  at nominal line voltage. Capacitors C1, C2 and C3 are for decoupling and phase compensation.

$R_{14} + P_{14}$  defines all on-chip bias and reference currents. With  $R_{14} + P_{14} = 24k\Omega$ , optimum conditions are set.  $P_{14}$  may be varied within  $\pm 10\%$  for calibration purposes. Any changes to  $R_{14}$  will affect the output quadratically (i.e.  $\Delta R = +5\%$ ,  $\Delta FOUT = +10\%$ ).

XTAL is a colour burst TV crystal ( $f = 3.5795$  MHz) for the oscillator. The oscillator frequency is divided down to  $1.7897$  MHz on-chip to supply the digital circuitry and the A/D converters.



Figure 1: Connection Diagram

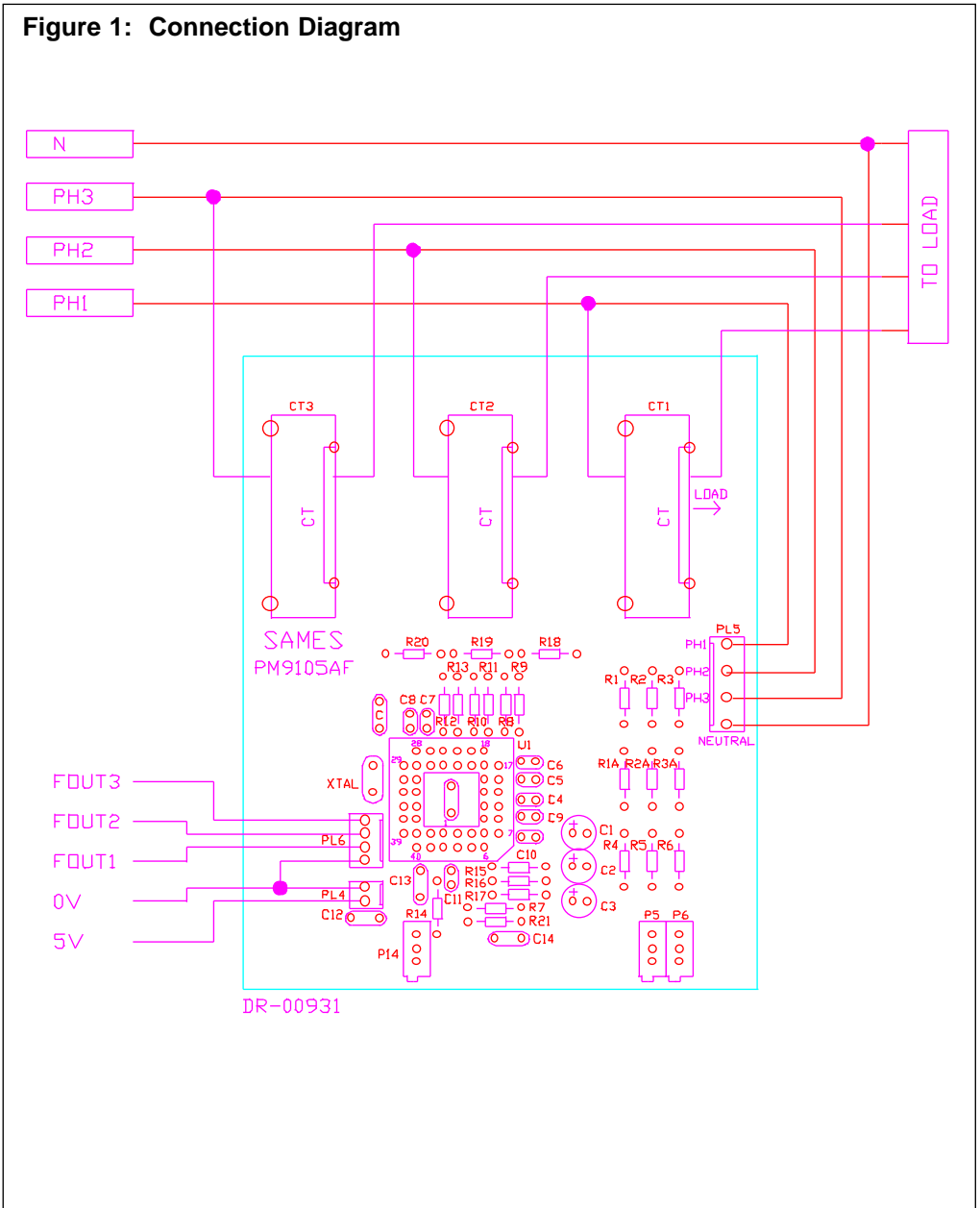



## Parts List for Application Circuit: Figure 2

Item	Symbol	Description	Detail
1	IC-1	SA9105AF/SA9105EF	PLCC-44
2	XTAL	Crystal, 3.5795 MHz	TV Crystal
3	R1	Resistor, 1%, ¼W, Metal	Note 4
4	R1A	Resistor, 1%, ¼W, Metal	Note 4
5	R2	Resistor, 1%, ¼W, Metal	Note 4
6	R2A	Resistor, 1%, ¼W, Metal	Note 4
7	R3	Resistor, 1%, ¼W, Metal	Note 4
8	R3A	Resistor, 1%, ¼W, Metal	Note 4
9	R4	Resistor, 24k, 1%, ¼W, Metal	
10	R5	Resistor, 22k, 1%, ¼W, Metal	
11	R6	Resistor, 22k, 1%, ¼W, Metal	
12	R7	Resistor, 820Ω, 1%, ¼W, Metal	
13	R8	Resistor, 2.7k, 1%, ¼W, Metal	Note 1
14	R9	Resistor, 2.7k, 1%, ¼W, Metal	Note 1
15	R10	Resistor, 2.7k, 1%, ¼W, Metal	Note 1
16	R11	Resistor, 2.7k, 1%, ¼W, Metal	Note 1
17	R12	Resistor, 2.7k, 1%, ¼W, Metal	Note 1
18	R13	Resistor, 2.7k, 1%, ¼W, Metal	Note 1
19	R14	Resistor, 22k, 1%, ¼W, Metal	
20	R15	Resistor, 1M, 1%, ¼W, Metal	
21	R16	Resistor, 1M, 1%, ¼W, Metal	
22	R17	Resistor, 1M, 1%, ¼W, Metal	
23	R18	Resistor, 2.7Ω, 1%, ¼W, Metal	Note 1
24	R19	Resistor, 2.7Ω, 1%, ¼W, Metal	Note 1
25	R20	Resistor, 2.7Ω, 1%, ¼W, Metal	Note 1
26	R21	Resistor, 820Ω, 1%, ¼W, Metal	
27	P5	Potentiometer, 4.7k	Multi turn
28	P6	Potentiometer, 4.7k	Multi turn
29	P14	Potentiometer, 4.7k	Multi turn
30	C1	Capacitor, electrolytic, 1μF, 16V	Note 2
31	C2	Capacitor, electrolytic, 1μF, 16V	Note 2
32	C3	Capacitor, electrolytic, 1μF, 16V	Note 2
33	C4	Capacitor, ceramic, 3.3nF	
34	C5	Capacitor, ceramic, 3.3nF	
35	C6	Capacitor, ceramic, 3.3nF	
36	C7	Capacitor, ceramic, 2.2nF	
37	C8	Capacitor, ceramic, 3.3nF	
38	C9	Capacitor, ceramic, 560pF	
39	C10	Capacitor, ceramic, 560pF	
40	C11	Capacitor, ceramic, 560pF	





**Parts List for Application Circuit: Figure 2 (Continued)**

Item	Symbol	Description	Detail
41	C12	Capacitor, ceramic, 100nF	
42	C13	Capacitor, ceramic, 820nF	Note 3
43	C14	Capacitor, ceramic, 100nF	

Note 1: Resistor ( $R_8$ ,  $R_9$ ,  $R_{10}$ ,  $R_{11}$ ,  $R_{12}$  and  $R_{13}$ ) values are dependant upon the selected values of the current transformer termination resistors  $R_{18}$ ,  $R_{19}$  and  $R_{20}$ .

Note 2: Capacitor values may be selected to compensate for phase errors caused by the current transformers

Note 3: Capacitor (C13) to be positioned as close to Supply Pins ( $V_{DD}$  &  $V_{SS}$ ) of IC-1, as possible.

Note 4: See the table below detailing the component values for the selected voltage standard.

Item	Symbol	Description		Detail
		PM9105AFA 115V	PM9105AFE 230V	
3	R1	200k $\Omega$	120k $\Omega$	
4	R1A	180k $\Omega$	82k $\Omega$	
5	R2	200k $\Omega$	120k $\Omega$	
6	R2A	180k $\Omega$	82k $\Omega$	
7	R3	200k $\Omega$	120k $\Omega$	
8	R3A	180k $\Omega$	82k $\Omega$	

**ORDERING INFORMATION**

Part Number	Description
PM9105AFA	3 X 115V, 3 X 80A Module
PM9105AFE	3 X 230V, 3 X 80A Module



**Disclaimer:** The information contained in this document is confidential and proprietary to South African Micro-Electronic Systems (Pty) Ltd ("SAMES") and may not be copied or disclosed to a third party, in whole or in part, without the express written consent of SAMES. The information contained herein is current as of the date of publication; however, delivery of this document shall not under any circumstances create any implication that the information contained herein is correct as of any time subsequent to such date. SAMES does not undertake to inform any recipient of this document of any changes in the information contained herein, and SAMES expressly reserves the right to make changes in such information, without notification, even if such changes would render information contained herein inaccurate or incomplete. SAMES makes no representation or warranty that any circuit designed by reference to the information contained herein, will function without errors and as intended by the designer.

Any Sales or technical questions may be posted to our e-mail address below:  
[energy@sames.co.za](mailto:energy@sames.co.za)

For the latest updates on datasheets, please visit our web site:  
<http://www.sames.co.za>

### **South African Micro-Electronic Systems (Pty) Ltd**

P O Box 15888,  
Lynn East,  
0039

Republic of South Africa,

33 Eland Street,  
Koedoespoort Industrial Area,  
Pretoria,  
Republic of South Africa

Tel: 012 333-6021

Fax: 012 333-8071

Tel: Int +27 12 333-6021

Fax: Int +27 12 333-8071

