

TENTATIVE TOSHIBA BIPOLAR LINEAR INTEGRATED CIRCUIT SILICON MONOLITHIC

TA8244H

MULTI-OUTPUT VOLTAGE REGULATOR (8.4V OUTPUTS)

The TA8244H is voltage regulator IC, designed for car audio application, has built-in 4 outputs.

Since each output consist of PNP transistor, the input-output differential voltage : V_{DEF} is very small ($V_{DEF} = 0.3V$ (Typ.)).

Regarding the automute function, it can be detected the minimum supply voltage automatically and the muting signal come out of pin①.

In addition, protectors for over voltage, output short and thermal shut down are involved.

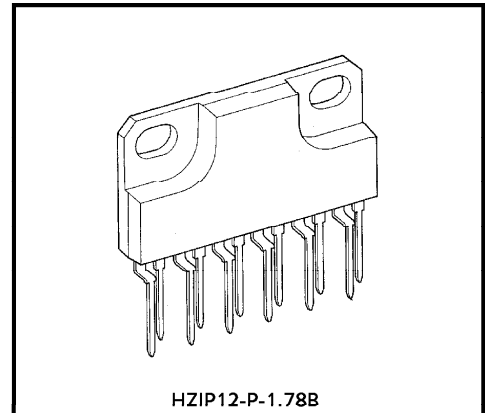

HZIP12-P-1.78B

Weight : 4.04g (Typ.)

FEATURES

- Channel outputs
 - OUT-1 : 8.4V (Typ.) / 200mA (MAX.)
 - OUT-2 : 8.4V (Typ.) / 120mA (MAX.)
 - OUT-3 : 8.4V (Typ.) / 100mA (MAX.)
 - OUT-4 : 8.4V (Typ.) / 180mA (MAX.)
- Very small input-output differential voltage : $V_{DEF} = 0.3V$ (Typ.)
- Auto-mute at minimum voltage detection (pin①)
- Various protector circuit
 - : Over voltage, Output to GND short, Thermal shut down
- Input operation voltage : $V_{IN(opr)} = 9.4$ to 18V

961001EBF1

- TOSHIBA is continually working to improve the quality and the reliability of its products. Nevertheless, semiconductor devices in general can malfunction or fail due to their inherent electrical sensitivity and vulnerability to physical stress. It is the responsibility of the buyer, when utilizing TOSHIBA products, to observe standards of safety, and to avoid situations in which a malfunction or failure of a TOSHIBA product could cause loss of human life, bodily injury or damage to property. In developing your designs, please ensure that TOSHIBA products are used within specified operating ranges as set forth in the most recent products specifications. Also, please keep in mind the precautions and conditions set forth in the TOSHIBA Semiconductor Reliability Handbook.
- This product generates heat during normal operation. However, substandard performance or malfunction may cause the product and its peripherals to reach abnormally high temperatures.
The product is often the final stage (the external output stage) of a circuit. Substandard performance or malfunction of the destination device to which the circuit supplies output may cause damage to the circuit or to the product.
- The products described in this document are subject to foreign exchange and foreign trade control laws.
- The information contained herein is presented only as a guide for the applications of our products. No responsibility is assumed by TOSHIBA CORPORATION for any infringements of intellectual property or other rights of the third parties which may result from its use. No license is granted by implication or otherwise under any intellectual property or other rights of TOSHIBA CORPORATION or others.
- The information contained herein is subject to change without notice.

BLOCK DIAGRAM

D : To suppress the minus surge voltage

(H : ONLY OUT1
 M : OUT4, OUT1, OUT2
 L : OUT3, OUT1, OUT2)

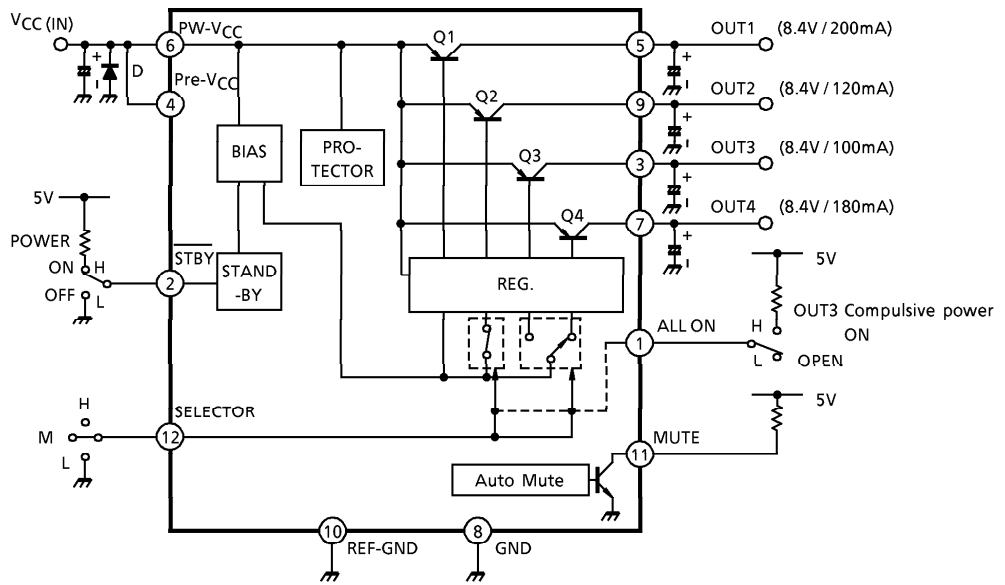

CAUTION AND APPLICATION

1. Auto mute at minimum supply voltage (pin⑪)

When V_{CC} turn OFF, the auto mute circuit is operated automatically and the muting signal come out of Pin⑪ as shown (Fig.1)

The detection voltage ; $V_{CC} (MUTE) = 8.9V \pm 0.3$ is fixed in internal circuit.

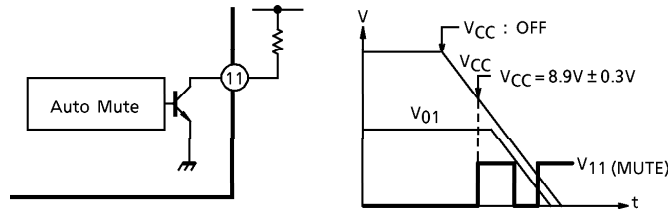

(Fig.1)

Since this function is synchronized the stand-by SW, the muting operation does not work after stand-by SW set at LOW.

2. IC protective diode in $V_{IN} < V_{OUT}$ mode : D

When the surge voltage is applied to the input and output terminals of IC or V_{OUT} becomes larger than V_{IN} ($V_{IN} < V_{OUT}$) at the time of power ON/OFF, insert a high speed switching diode : D.

3. Power limiting register : R_{SD}

If V_{IN} is too high, insert a power limiting register : R_{SD} to reduce power dissipation of IC.

4. Input surge protective zener diode : ZD

Though an over voltage protective circuit (for positive surge) is built in, if excessive surge is input, insert a surge protective zener diode : ZD.

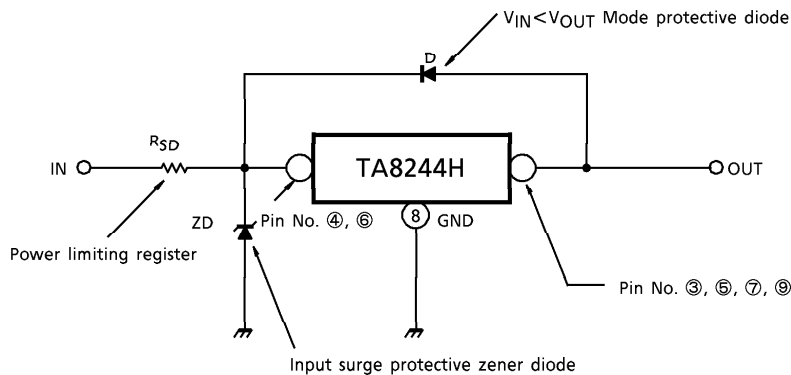

(Fig.2)

5. Design of heat sink

Thermal resistance : θ_{J-T} of the package of this IC can be obtained from (Fig.3) according to the following expression :

$$\theta_{J-T} = \frac{150^{\circ}\text{C} - 75^{\circ}\text{C}}{25\text{W}} = 3^{\circ}\text{C/W} \quad (\text{temperature from the junction to the TAB}) \cdots \text{Expression } \textcircled{1}$$

Thermal resistance : θ_{HS} of the heat sink attached to this IC is decided by the following expression :

$$\theta_{HS} = \frac{T_j \text{ MAX} - T_a}{P_D \text{ MAX}} - \theta_{j-T} \cdots \text{Expression } \textcircled{2}$$

$$P_D \text{ MAX} = (V_{IN} (\text{MAX}) - V_{OUT1, 2, 4} (\text{MIN})) \times (I_{O1} + I_{O2} + I_{O4}) \cdots \text{Expression } \textcircled{3}$$

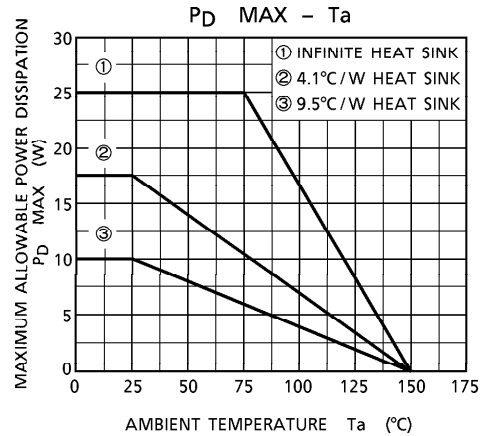

(Fig.3)

For instance, if this IC is used under the conditions of $V_{IN} (\text{MAX}) = 16\text{V}$, $I_{O1} = 200\text{mA}$, $I_{O2} = 120\text{mA}$, $I_{O4} = 180\text{mA}$ and T_a is up to 85°C from expression $\textcircled{3}$.

$$P_D \text{ MAX} = (16\text{V} - 8.1\text{V}) \times (200\text{mA} + 120\text{mA} + 180\text{mA}) = 3.95\text{W}$$

Substituting $P_D \text{ MAX} = 3.95\text{W}$ into expression $\textcircled{2}$, above, θ_{HS} is obtained as follows :

$$\theta_{HS} = \frac{150^{\circ}\text{C} - 85^{\circ}\text{C}}{3.95\text{W}} - 3^{\circ}\text{C/W} = 13.46^{\circ}\text{C/W}$$

Accordingly, a heat sink having $\theta_{HS} = 13.46^{\circ}\text{C/W}$ becomes necessary and referring to (Fig.4), it can be set to be an aluminum plate 2mm in thickness and about 20cm^2 in area. However, when a heat sink is actually mounted to IC, the contact resistance is generated on its contacting surface and heat conduction becomes worse.

Therefore, a heat sink shall be designed with a sufficient margin of heat sink given.

Further, the TAB shall be grounded or kept open when the IC is used.

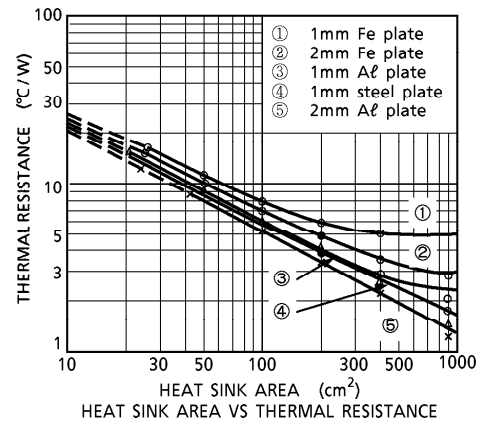

(Fig.4)

6. Output capacitor for preventing the oscillation.

Type and capacity of a capacitor to be used between the output and GND shall be decided after thoroughly examining print pattern, route of connection, at high/low temperature, etc. In particular, if inductor component is connected to the output, it is necessary to make the capacity larger than the recommended value.

7. Protector operation

When over voltage or thermal shut down protector is operated, all outputs are cut off. And in case of output short to GND mode, output current is limited as shown (Fig.5)

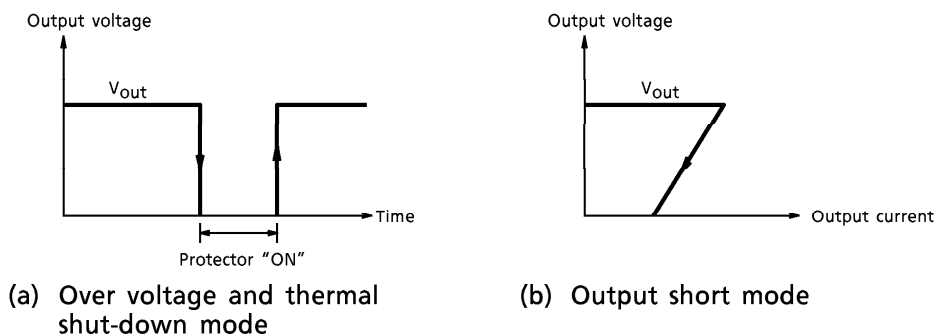

(Fig.5)

8. All ON function (pin①) ... OUT3 compulsive ON mode

When we would like to check the output voltage at the production line, We can set up the all output operation mode compulsively according to the following condition.

All ON mode	All ON Terminal ① : apply the DC voltage is more than 3V Selector Terminal ⑫ : set up M position
-------------	---

In addition, if pin① is connected to GND, OUT3 cut OFF compulsively. Therefore, basically pin① shall be opened in the normal operation.

9. Diode for suppress the minus surge voltage

Since the TA8244H's break down voltage is a little bit lower about the minus surge, diode must be connected between V_{CC} and GND in order to prevent IC breakdown. However, generally it is using in the car stereo equipment to avoid the IC breakdown about the reverse battery mode. The breakdown voltage and type of diode should be decided after thoroughly examining the minus surge voltage level and the current of the reverse battery.

MAXIMUM RATINGS (Ta = 25°C)

CHARACTERISTIC	SYMBOL	RATING	UNIT
Peak Input Voltage (0.2s)	V _{IN surge}	50	V
DC Input Voltage	V _{IN DC}	25	V
Operating Input Voltage	V _{IN opr}	18	V
Power Dissipation	P _D	25	W
Operating Temperature	T _{opr}	- 40~85	°C
Storage Temperature	T _{stg}	- 55~150	°C

ELECTRICAL CHARACTERISTICS (Unless otherwise specified, V_{IN} = 13.2V, Ta = 25°C)

CHARACTERISTIC	SYMBOL	TEST CIR-CUIT	TEST CONDITION	MIN.	TYP.	MAX.	UNIT
Output Voltage	OUT 1	V _{O1}	— I _{O1} = 200mA	8.1	8.4	8.7	V
	OUT 2	V _{O2}	— I _{O2} = 120mA				
	OUT 3	V _{O3}	— I _{O3} = 100mA				
	OUT 4	V _{O4}	— I _{O4} = 180mA				
Bias Current	LF MODE	I _{BH}	— Selector (pin⑩) : H I _{O1} = 0	—	12	26	mA
	FM MODE	I _{BM}	— Selector (pin⑩) : M I _{O1} , I _{O2} , I _{O4} = 0	—	23	48	
	AM MODE	I _{BL}	— Selector (pin⑩) : L I _{O1} , I _{O2} , I _{O3} = 0	—	20	42	
Input Variation	ΔV _{O1}	—	V _{IN} = 9.4~18V I _{O1} = 200mA, I _{O2} = 120mA I _{O3} = 100mA, I _{O4} = 180mA	—	—	± 50	mV
Load Variation	ΔV _{O2}	—	I _O : 0mA to MAX.	—	—	± 50	mV
Input to Output Voltage Difference	V _{DEF}	—	I _{O1} = 200mA, I _{O2} = 120mA I _{O3} = 100mA, I _{O4} = 180mA	—	0.3	0.6	V
Ripple Rejection Ratio	R. R.	—	f = 100Hz V _{ripple} = 0.775V _{rms} (0dBm) I _{O1} = 200mA, I _{O2} = 120mA I _{O3} = 100mA, I _{O4} = 180mA	50	65	—	dB
Temperature Coefficient of Output Voltage	TC _{VO}	—	I _{O1} = 200mA, I _{O2} = 120mA I _{O3} = 100mA, I _{O4} = 180mA	—	+ 1	—	mV / °C
Maximum Output Current	OUT 1	I _{MAX 1}	—	200	—	—	mA
	OUT 2	I _{MAX 2}	—	120	—	—	
	OUT 3	I _{MAX 3}	—	100	—	—	
	OUT 4	I _{MAX 4}	—	180	—	—	
Stand-by Input Resistance	R _{STBY}	(*)	—	37	47	57	kΩ
Selector Input Resistance	R _{SLCT}	(*)	—	40	50	60	kΩ
Stand-by Current	I _{SB}	—	Voltage of pin② : V ₂ = 0V	—	1	10	μA
Output Noise Voltage	V _{NO}	—	I _{O1} = 200mA, I _{O2} = 120mA I _{O3} = 100mA, I _{O4} = 180mA	—	0.2	0.5	mV _{rms}

CHARACTERISTIC		SYMBOL	TEST CIRCUIT	TEST CONDITION	MIN.	TYP.	MAX.	UNIT
Muting Operation Supply Voltage		$V_{CC}(\text{Mute})$	—	Refer to (*2)	8.6	8.9	9.2	V
Difference Voltage $V_{CC}(\text{MUTE})$ -OUT1		$\Delta V_{CC}(\text{Mute})$	—	—	0.2	0.5	—	V
Control Voltage	Stand-by (Pin②)	V_H	—	Power ON	3.0	—	V_{CC}	V
		V_L	—	Power OFF	0	—	1.0	V
	Selector (Pin⑫)	V_H	—	Only OUT1	7.0	—	V_{CC}	V
		V_M	—	OUT4, OUT1, OUT2	3.0	—	5.5	V
		V_L	—	OUT3, OUT1, OUT2	0	—	1.0	V
	ALL ON (Pin①)	V_H	—	pin⑫ : M→OUT1~OUT4	3.0	—	V_{CC}	V
V_L		—	(*1)	—	—	—	V	

(*1) Pin① should be open in the normal operation.

Refer to the application explanation as shown page 5

(*2)

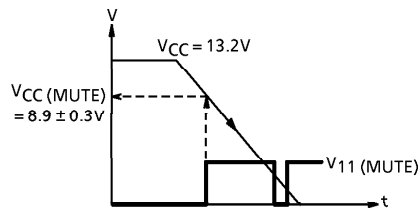

OUTPUT CONTROL LOGIC

ALL ON TERMINAL	STAND-BY TERMINAL	SELECTOR TERMINAL	OUTPUT			
ALL ON	STBY	SELECTOR	OUT1	OUT2	OUT3	OUT4
PIN①	PIN②	PIN⑫	PIN⑤	PIN⑨	PIN③	PIN⑦
OPEN	L	—	OFF	OFF	OFF	OFF
OPEN	H	H	ON	OFF	OFF	OFF
OPEN	H	M	ON	ON	OFF	ON
OPEN	H	L	ON	ON	ON	OFF
H	H	M	ON	ON	ON	ON
H	L	—	OFF	OFF	OFF	OFF

TEST CIRCUIT

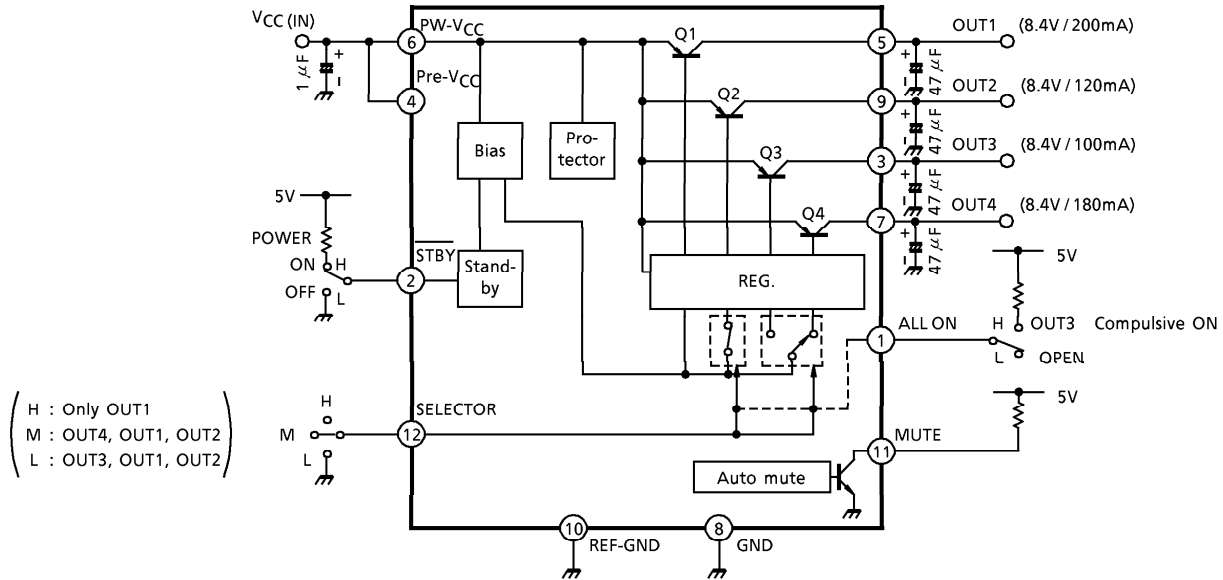

(*) The resistance
Measurement method of pin ② and ⑫

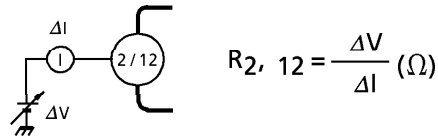

APPLICATION CIRCUIT

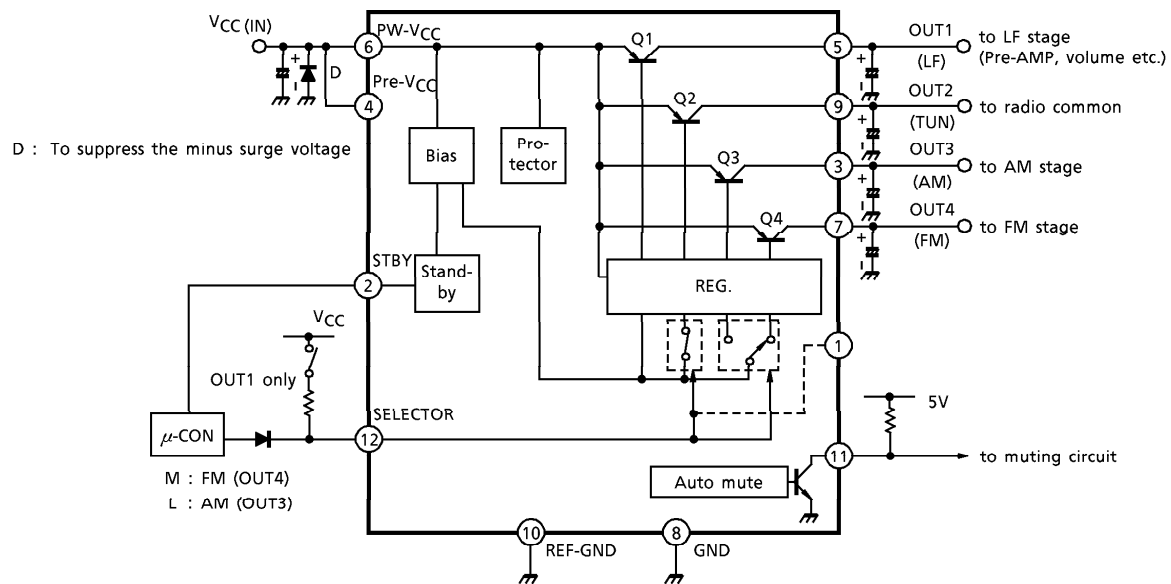

V5, V9, V3, V7 - V_{IN}

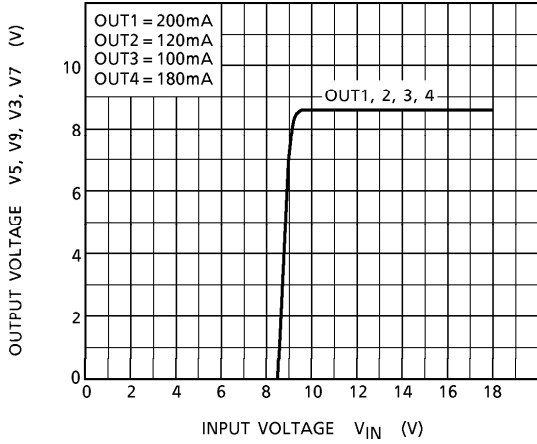

V5, V9, V3, V7 - V_{DEF}

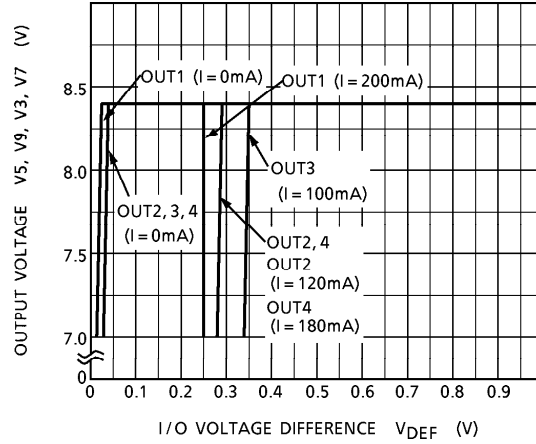

V5, V9, V3, V7 - I₅, I₉, I₃, I₇

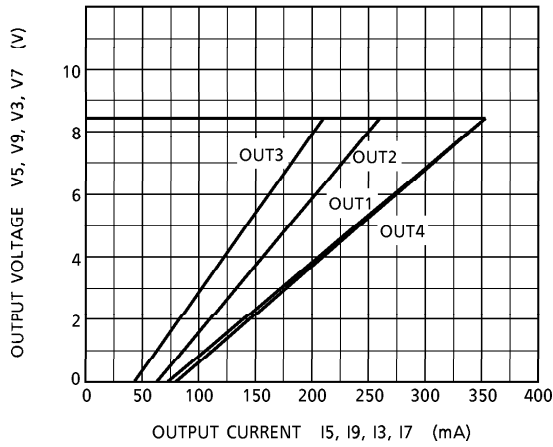

R.R. - f

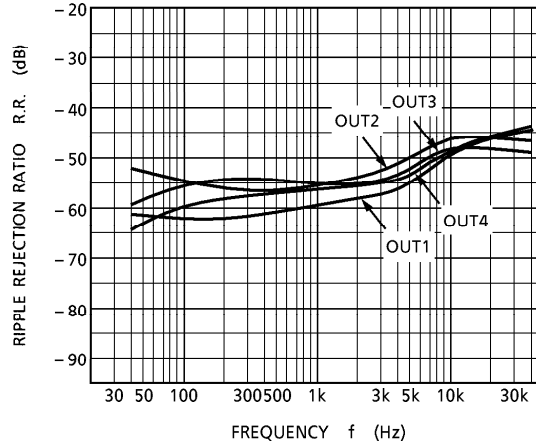

V_H, V_M, V_L - T_a

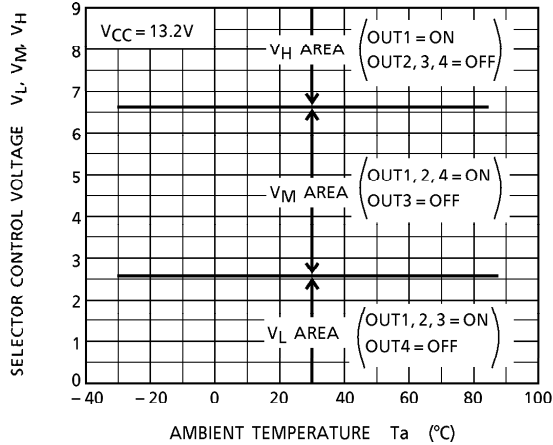

P_D - T_a

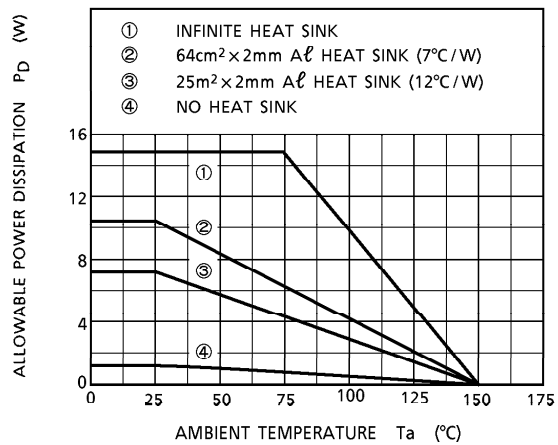

OUTLINE DRAWING
HZIP12-P-1.78B

Unit : mm

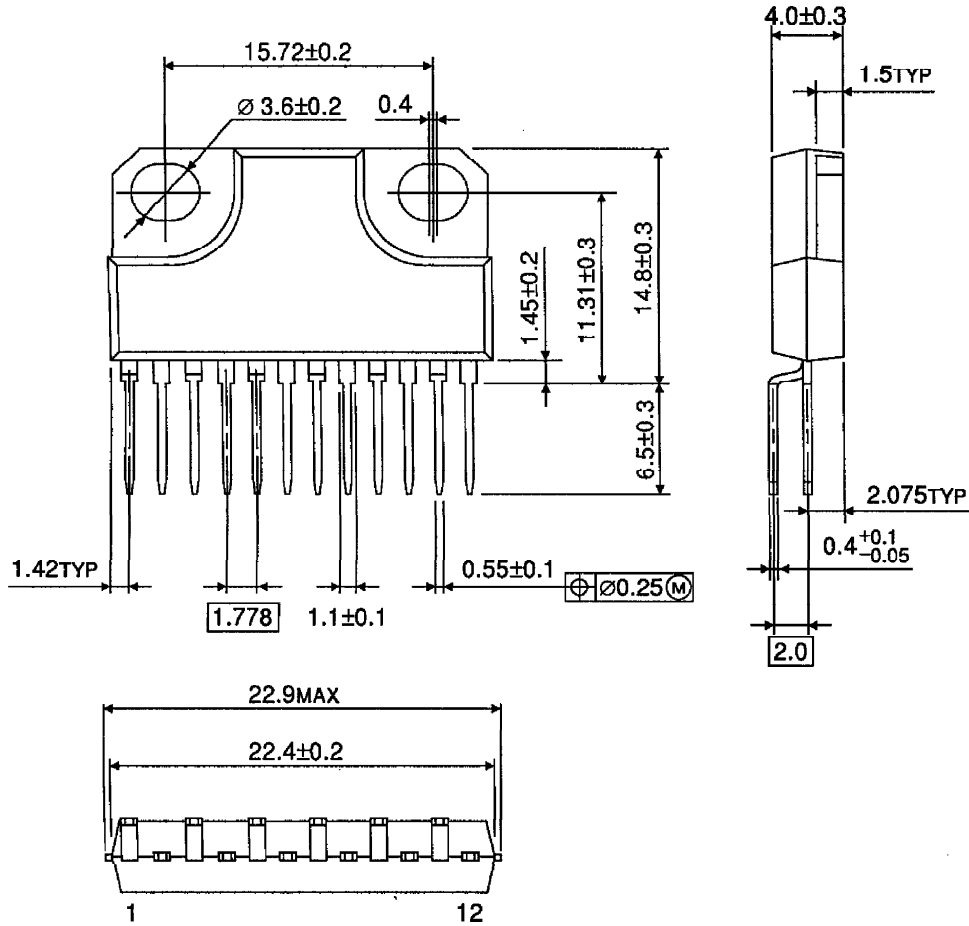

Weight : 4.04g (Typ.)