



87C196KR/KQ 87C196JV/JT 87C196JR/JQ ADVANCED 16-BIT CHMOS MICROCONTROLLER

Automotive

- -40°C to +125°C Ambient
- High Performance CHMOS 16-Bit CPU
- Up to 48 Kbytes of On-Chip EPROM
- Up to 1.5 Kbytes of On-Chip Register RAM
- Up to 512 Bytes of Additional RAM (Code RAM)
- Register-Register Architecture
- Up to 8 Channel/10-Bit A/D with Sample/Hold
- Up to 37 Prioritized Interrupt Sources
- Up to Seven 8-Bit (56) I/O Ports
- Full Duplex Serial I/O Port
- Dedicated Baud Rate Generator
- Interprocessor Communication Slave Port
- High Speed Peripheral Transaction Server (PTS)
- Two 16-Bit Software Timers
- 10 High Speed Capture/Compare (EPA)
- Full Duplex Synchronous Serial I/O Port (SSIO)
- Two Flexible 16-Bit Timer/Counters
- Quadrature Counting Inputs
- Flexible 8-/16-Bit External Bus
- Programmable Bus (HLD/HLDA)
- 1.75 μ s 16 x 16 Multiply
- 3 μ s 32/16 Divide
- 68-Pin and 52-Pin PLCC Packages

| Device | Pins/Package | EPROM | Reg RAM | Code RAM | I/O | EPA | SIO | SSIO | A/D |
|----------|--------------|-------|---------|----------|-----|-----|-----|------|-----|
| 87C196KR | 68-pin PLCC | 16K | 488 | 256 | 56 | 10 | Y | Y | 8 |
| 87C196KQ | 68-pin PLCC | 12K | 360 | 128 | 56 | 10 | Y | Y | 8 |
| 87C196JV | 52-pin PLCC | 48K | 1.5K | 512 | 41 | 6 | Y | Y | 6 |
| 87C196JT | 52-pin PLCC | 32K | 1.0K | 512 | 41 | 6 | Y | Y | 6 |
| 87C196JR | 52-pin PLCC | 16K | 488 | 256 | 41 | 6 | Y | Y | 6 |
| 87C196JQ | 52-pin PLCC | 12K | 360 | 128 | 41 | 6 | Y | Y | 6 |

The 87C196KR/KQ JV/JT JR/JQ devices represent the fourth generation of MCS® 96 Microcontroller products implemented on Intel's advanced 1 micron process technology. These products are based on the 80C196KB device with improvements for automotive applications. The instruction set is a true super set of 80C196KB. The 87C196JR is a 52-pin version of the 87C196KR device, while the 87C196KQ/JQ are memory scalars of the 87C196KR/JR.

The 87C196JV/JT A-step devices (JV-A, JT-A) are the newest members of the MCS 96 microcontroller family. These devices are memory scalars of the 87C196JR D-step (JR-D) and are designed for strict functional and electrical compatibility. The JT-A has 32 Kbytes of on-chip EPROM, 1.0 Kbytes of Register RAM and 512 bytes of Code RAM. The JV-A has 48 Kbytes of on-chip EPROM, 1.5 Kbytes of Register RAM and 512 bytes of Code RAM.

*Other brands and names are the property of their respective owners. Information in this document is provided in connection with Intel products. Intel assumes no liability whatsoever, including infringement of any patent or copyright, for sale and use of Intel products except as provided in Intel's Terms and Conditions of Sale for such products. Intel retains the right to make changes to these specifications at any time, without notice. Microcomputer Products may have minor variations to this specification known as errata.
COPYRIGHT © INTEL CORPORATION, 1995 November 1995 Order Number: 270827-006



The MCS 96 microcontroller family members are all high performance microcontrollers with a 16-bit CPU. The 87C196Kx/Jx family members listed above are composed of the high-speed (16 MHz) core as well as the following peripherals: up to 48 Kbytes of Programmable EPROM, up to 1.5 Kbytes of Register RAM, 512 bytes of code RAM (16-bit addressing modes) with the ability to execute from this RAM space, an eight channel-10-Bit/ ± 3 LSB analog to digital converter with programmable S/H times with conversion times $< 5 \mu\text{s}$ at 16 MHz, an asynchronous/synchronous serial I/O port (8096 compatible) with a dedicated 16-bit baud rate generator, an additional synchronous serial I/O port (8096 compatible) with a dedicated 16-bit baud rate generator, an additional synchronous serial I/O port with full duplex master/slave transceivers, a flexible timer/counter structure with prescaler, cascading, and quadrature capabilities, 10 modularized multiplexed high speed I/O for capture and compare (called Event Processor Array) with 250 ns resolution and double buffered inputs, a sophisticated prioritized interrupt structure with programmable Peripheral Transaction Server (PTS). The PTS has several channel modes, including single/burst block transfers from any memory location to any memory location, a PWM and PWM toggle mode to be used in conjunction with the EPA, and an A/D scan mode.

Additional SFR space is allocated for the EPA and can be "windowed" into the lower Register RAM area.

Please refer to the following datasheets for higher frequency versions of devices contained within this datasheet: 20 MHz 87C196JT: Order # 272529; 20 MHz 87C196JV: Order Number 272580.

ARCHITECTURE

The 87C196KR/KQ/JV/JT/JR/JQ are members of the MCS 96 microcontroller family, has the same architecture and uses the same instruction set as the 80C196KB/KC. Many new features have been added including:

CPU FEATURES

- Powerdown and Idle Modes
- 16 MHz Operating Frequency
- A High Performance Peripheral Transaction Server (PTS)

- Up to 37 Interrupt Vectors
- Up to 512 Bytes of Code RAM
- Up to 1.5 Kbytes of Register RAM
- "Windowing" Allows 8-Bit Addressing to Some 16-Bit Addresses
- $1.75 \mu\text{s}$ 16 x 16 Multiply
- $3 \mu\text{s}$ 32/16 Divide
- Oscillator Fail Detect

PERIPHERAL FEATURES

- Programmable A/D Conversion and S/H Times
- 10 Capture/Compare I/O with 2 Flexible Timers
- Synchronous Serial I/O Port for Full Duplex Serial I/O
- Total Utilization of ALL Available Pins (I/O Mux'd with Control)
- 2 16-Bit Timers with Prescale, Cascading and Quadrature Counting Capabilities
- Up to 12 Externally Triggered Interrupts

NEW INSTRUCTIONS

XCH/XCHB

Exchange the contents of two locations, either Word or Byte is supported.

BMOVi

Interruptable Block Move Instruction, allows the user to be interrupted during long executing Block Moves.

TIJMP

Table Indirect JUMP. This instruction incorporates a way to do complex CASE level branches through one instruction. An example of such code savings: several interrupt sources and only one interrupt vector. The TIJMP instruction will sort through the sources and branch to the appropriate sub-code level in one instruction. This instruction was added especially for the EPA structure, but has other code saving advantages.

EPTS/DPTS

Enable and Disable PTS Interrupts (Works like EI and DI).



SFR OPERATION

An additional 256 bytes of SFR registers were added to the 8XC196KR devices. These locations were added to support the wide range of on-chip peripherals that the 8XC196KR has. This memory space

(1F00-1FFFH) has the ability to be addressed as direct 8-bit addresses through the "windowing" technique. Any 32-, 64- or 128-byte section can be relocated in the upper 32, 64 or 128 bytes of the internal register RAM (080-FFH) address space.

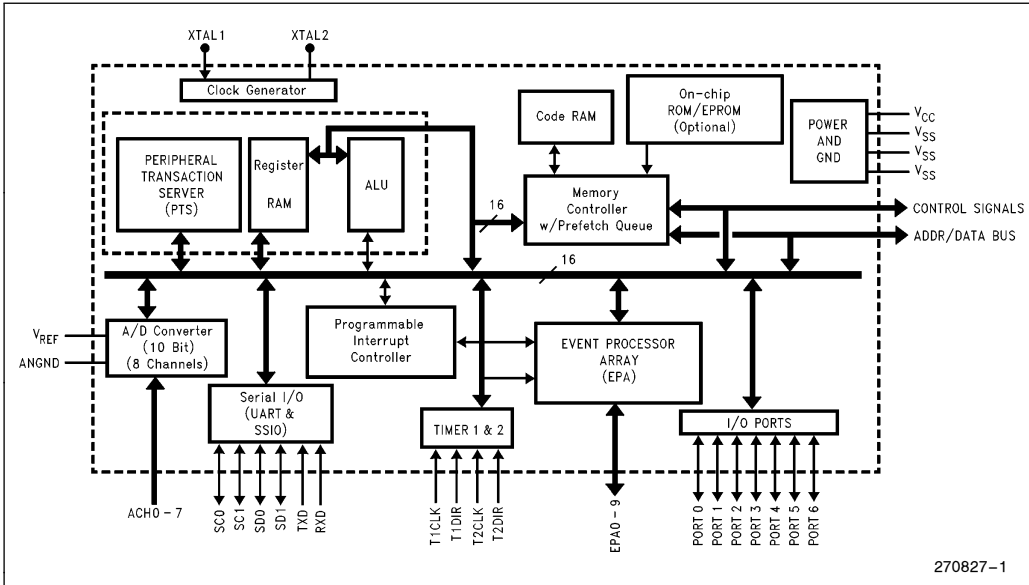

Figure 1. Block Diagram

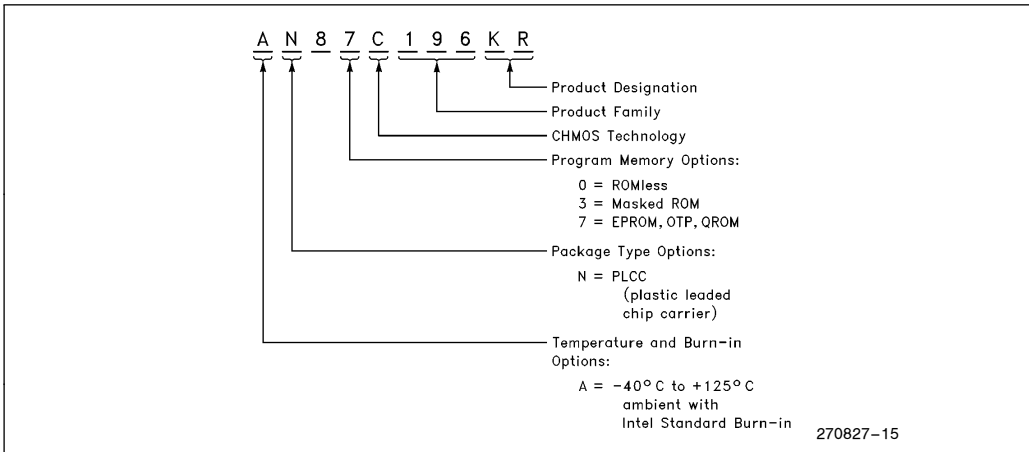

Figure 2. The 8XC196KR Family Nomenclature

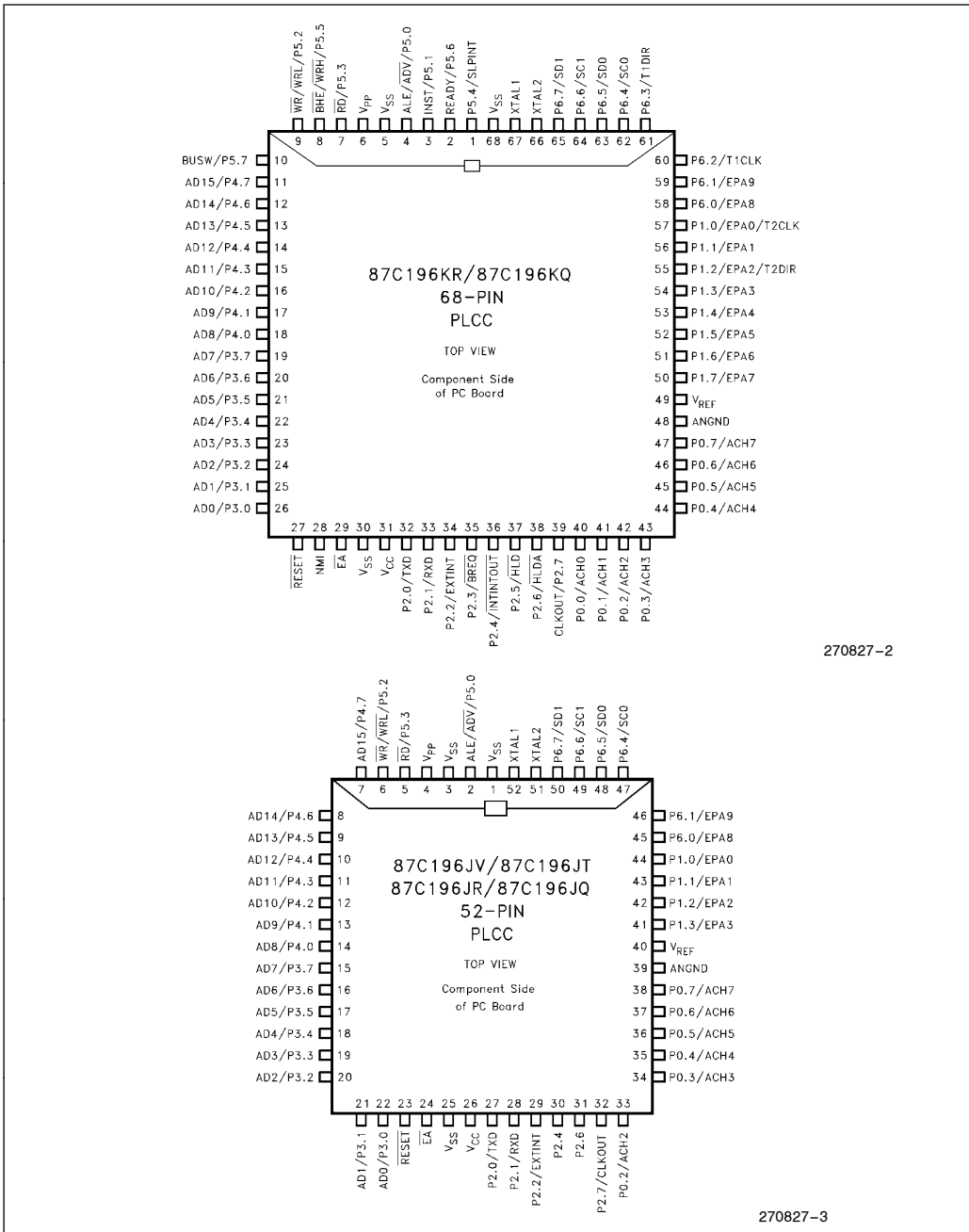

Figure 3. Package Diagrams

PIN DESCRIPTIONS

| Symbol | Name and Function |
|---|--|
| V _{CC} | Main supply voltage (+5V). |
| V _{SS} , V _{SS} , V _{SS} | Digital circuit ground (0V). There are three V _{SS} pins, all of which MUST be connected to a single ground plane. |
| V _{REF} | Reference for the A/D converter (+5V). V _{REF} is also the supply voltage to the analog portion of the A/D converter and the logic used to read Port 0. Must be connected for A/D and Port 0 to function. |
| V _{PP} | Programming voltage for the EPROM parts. It should be +12.5V for programming. It is also the timing pin for the return from powerdown circuit. Connect this pin with a 1 μF capacitor to V _{SS} and a 1 MΩ resistor to V _{CC} . If this function is not used, V _{PP} may be tied to V _{CC} . |
| ANGND | Reference ground for the A/D converter. Must be held at nominally the same potential as V _{SS} . |
| XTAL1 | Input of the oscillator inverter and the internal clock generator. |
| XTAL2 | Output of the oscillator inverter. |
| P2.7/CLKOUT | Output of the internal clock generator. The frequency is 1/2 the oscillator frequency. It has a 50% duty cycle. Also LSIO pin. |
| $\overline{\text{RESET}}$ | Reset input to the chip. Input low for at least 16 state times will reset the chip. The subsequent low to high transition resynchronizes CLKOUT and commences a 10-state time sequence in which the PSW is cleared, bytes are read from 2018H and 201AH loading the CCBs, and a jump to location 2080H is executed. Input high for normal operation. $\overline{\text{RESET}}$ has an internal pullup. |
| P5.7/BUSWIDTH | Input for bus width selection. If CCR bit 1 is a one and CCR1 bit 2 is a one, this pin dynamically controls the Bus width of the bus cycle in progress. If BUSWIDTH is low, an 8-bit cycle occurs. If BUSWIDTH is high, a 16-bit cycle occurs. If CCR bit 1 is "0" and CCR1 bit 2 is "1", all bus cycles are 8-bit, if CCR bit 1 is "1" and CCR1 bit 2 is "0", all bus cycles are 16-bit. CCR bit 1 = "0" and CCR1 bit 2 = "0" is illegal. Also an LSIO pin when not used as BUSWIDTH. |
| NMI | A positive transition causes a non-maskable interrupt vector through memory location 203EH. Used by Intel (GND this pin). |
| P5.1/INST | Output high during an external memory read indicates the read is an instruction fetch. INST is valid throughout the bus cycle. INST is active only during external memory fetches, during internal [EP]ROM fetches INST is held low. Also LSIO when not INST. |
| $\overline{\text{EA}}$ | Input for memory select (External Access). $\overline{\text{EA}}$ equal to a high causes memory accesses to locations 2000H through 5FFFH to be directed to on-chip EPROM/ROM. $\overline{\text{EA}}$ equal to a low causes accesses to these locations to be directed to off-chip memory. $\overline{\text{EA}} = +12.5\text{V}$ causes execution to begin in the Programming Mode. $\overline{\text{EA}}$ latched at reset. |
| P5.0/ALE/ $\overline{\text{ADV}}$ | Address Latch Enable or Address Valid output, as selected by CCR. Both pin options provide a latch to demultiplex the address from the address/data bus. When the pin is $\overline{\text{ADV}}$, it goes inactive (high) at the end of the bus cycle. $\overline{\text{ADV}}$ can be used as a chip select for external memory. ALE/ $\overline{\text{ADV}}$ is active only during external memory accesses. Also LSIO when not used as ALE. |

PIN DESCRIPTIONS (Continued)

| Symbol | Name and Function |
|---------------------------------------|--|
| P5.3/ \overline{RD} | Read signal output to external memory. \overline{RD} is active only during external memory reads or LSIO when not used as \overline{RD} . |
| P5.2/ $\overline{WR}/\overline{WRL}$ | Write and Write Low output to external memory, as selected by the CCR, \overline{WR} will go low for every external write, while \overline{WRL} will go low only for external writes where an even byte is being written. $\overline{WR}/\overline{WRL}$ is active during external memory writes. Also an LSIO pin when not used as $\overline{WR}/\overline{WRL}$. |
| P5.5/ $\overline{BHE}/\overline{WRH}$ | Byte High Enable or Write High output, as selected by the CCR. $\overline{BHE} = 0$ selects the bank of memory that is connected to the high byte of the data bus. $A0 = 0$ selects that bank of memory that is connected to the low byte. Thus accesses to a 16-bit wide memory can be to the low byte only ($A0 = 0, \overline{BHE} = 1$), to the high byte only ($A0 = 1, \overline{BHE} = 0$) or both bytes ($A0 = 0, \overline{BHE} = 0$). If the \overline{WRH} function is selected, the pin will go low if the bus cycle is writing to an odd memory location. $\overline{BHE}/\overline{WRH}$ is only valid during 16-bit external memory write cycles. Also an LSIO pin when not $\overline{BHE}/\overline{WRH}$. |
| P5.6/READY | Ready input to lengthen external memory cycles, for interfacing with slow or dynamic memory, or for bus sharing. If the pin is high, CPU operation continues in a normal manner. If the pin is low prior to the falling edge of CLKOUT, the memory controller goes into a wait state mode until the next positive transition in CLKOUT occurs with READY high. When external memory is not used, READY has no effect. The max number of wait states inserted into the bus cycle is controlled by the CCR/CCR1. Also an LSIO pin when READY is not selected. |
| P5.4/SLPINT | Dual functional I/O pin. As a bidirectional port pin or as a system function. The system function is a Slave Port Interrupt Output Pin. |
| P6.2/T1CLK | Dual function I/O pin. Primary function is that of a bidirectional I/O pin, however it may also be used as a TIMER1 Clock input. The TIMER1 will increment or decrement on both positive and negative edges of this pin. |
| P6.3/T1DIR | Dual function I/O pin. Primary function is that of a bidirectional I/O pin, however it may also be used as a TIMER1 Direction input. The TIMER1 will increment when this pin is high and decrements when this pin is low. |
| PORT1/EPA0–7 P6.0–6.1/EPA8–9 | Dual function I/O port pins. Primary function is that of bidirectional I/O. System function is that of High Speed capture and compare. EPA0 and EPA2 have yet another function of T2CLK and T2DIR of the TIMER2 timer/counter. |
| PORT 0/ACH0–7 | 8-bit high impedance input-only port. These pins can be used as digital inputs and/or as analog inputs to the on-chip A/D converter. These pins are also used as inputs to EPROM parts to select the Programming Mode. |
| P6.4–6.7/SSIO | Dual function I/O ports that have a system function as Synchronous Serial I/O. Two pins are clocks and two pins are data, providing full duplex capability. |
| PORT 2 | 8-bit multi-functional port. All of its pins are shared with other functions. |
| PORT 3 and 4 | 8-bit bidirectional I/O ports with open drain outputs. These pins are shared with the multiplexed address/data bus which has strong internal pullups. |



ELECTRICAL CHARACTERISTICS

NOTICE: This is a production data sheet. The specifications are subject to change without notice.

ABSOLUTE MAXIMUM RATINGS**

Storage Temperature -60°C to +150°C
 Voltage from V_{PP} or $\bar{E}A$ to V_{SS} or ANGND -0.5V to +13.0V
 Voltage from Any Other Pin to V_{SS} or ANGND -0.5V to +7.0V
 This includes V_{PP} on ROM and CPU devices.
 Power Dissipation.....0.5W

**WARNING: Stressing the device beyond the "Absolute Maximum Ratings" may cause permanent damage. These are stress ratings only. Operation beyond the "Operating Conditions" is not recommended and extended exposure beyond the "Operating Conditions" may affect device reliability.*

OPERATING CONDITIONS

| Symbol | Parameter | Min | Max | Units |
|------------------|--------------------------------|------|------|--------|
| T _A | Ambient Temperature under Bias | -40 | +125 | °C |
| V _{CC} | Digital Supply Voltage | 4.50 | 5.50 | V |
| V _{REF} | Analog Supply Voltage | 4.50 | 5.50 | V |
| F _{OSC} | Oscillator Frequency | 4 | 16 | MHz(4) |

NOTE:
 ANGND and V_{SS} should be nominally at the same potential.

DC CHARACTERISTICS (Under Listed Operating Conditions)

| Symbol | Parameter | Min | Typ | Max | Units | Test Conditions |
|-------------------|--|---------------------|-----------------|-----------------------|-------------|---|
| I _{CC} | V _{CC} Supply Current (-40°C to +125°C Ambient) | | 50 | 75 (JV = 80) | mA | XTAL1 = 16 MHz, V _{CC} = V _{PP} = V _{REF} = 5.5V (While Device in Reset) |
| I _{CC1} | Active Mode Supply Current (Typical) | | 50 (JV = 55) | | mA | |
| I _{REF} | A/D Reference Supply Current | | 2 | 5 | mA | |
| I _{IDLE} | Idle Mode Current | | 15 | 30 (JV = 32) | mA | XTAL1 = 16 MHz, V _{CC} = V _{PP} = V _{REF} = 5.5V |
| I _{PD} | Powerdown Mode Current | | 50 | TBD | μA | V _{CC} = V _{PP} = V _{REF} = 5.5V (Note 6) |
| V _{IL} | Input Low Voltage (All Pins) | -0.5V | | 0.3 V _{CC} | V | |
| V _{IH} | Input High Voltage (All Pins) | 0.7 V _{CC} | | V _{CC} + 0.5 | V | (Note 7) |
| V _{OL} | Output Low Voltage (Outputs Configured as Push/Pull) | | | 0.3 0.45 1.5 | V V V | I _{OL} = 200 μA (Notes 3, 5) I _{OL} = 3.2 mA I _{OL} = 7.0 mA |



DC CHARACTERISTICS (Under Listed Operating Conditions) (Continued)

| Symbol | Parameter | Min | Typ | Max | Units | Test Conditions |
|---|---|---|------|-------------------------|----------------|---|
| V _{OH} | Output High Voltage (Outputs Configured as Push/Pull) | V _{CC} - 0.3 V _{CC} - 0.7 V _{CC} - 1.5 | | | V V V | I _{OH} = -200 μA (Notes 3, 5) I _{OH} = -3.2 mA I _{OH} = -7.0 mA |
| I _{LI} | Input Leakage Current (Std. Inputs) | | | ± 8 JT/JV: ± 10 | μA | V _{SS} ≤ V _{IN} ≤ V _{CC} (Note 2) |
| I _{LI1} | Input Leakage Current (Port 0—A/D Inputs) | | | ± 1 JT/JV: ± 2 | μA | V _{SS} ≤ V _{IN} ≤ V _{REF} |
| I _{IH} | Input High Current (NMI Pin) | | | + 175 | μA | V _{SS} ≤ V _{IN} ≤ V _{CC} |
| V _{OH2} | Output High Voltage in RESET | V _{CC} - 1V | | | V | I _{OH} = -15 μA (Notes 1, 8) |
| I _{OH2} (KR, KQ) | Output High Current in RESET | - 6 - 15 - 20 | | - 35 - 60 - 70 | μA μA μA | V _{OH2} = V _{CC} - 1.0V V _{OH2} = V _{CC} - 2.5V V _{OH2} = V _{CC} - 4.0V |
| I _{OH2} (JV, JT, JR-D, JQ-D) | Output High Current in RESET | - 30 - 75 - 90 | | - 120 - 240 - 280 | μA μA μA | V _{OH2} = V _{CC} - 1.0V V _{OH2} = V _{CC} - 2.5V V _{OH2} = V _{CC} - 4.0V |
| R _{RST} | Reset Pullup Resistor | 6K | | 65K | Ω | |
| V _{OL3} | Output Low Voltage in RESET (RESET Pin only) | | | 0.3 0.5 0.8 | V V V | I _{OL3} = 4 mA (Note 9) I _{OL3} = 6 mA I _{OL3} = 10 mA |
| C _S | Pin Capacitance (Any Pin to V _{SS}) | | | 10 | pF | F _{TEST} = 1.0 MHz |
| R _{WPU} | Weak Pullup Resistance (Approx) | | 150K | | Ω | (Note 6) |

NOTES:

- All BD (bidirectional) pins except P5.1/INST and P2.7/CLKOUT which are excluded due to their not being weakly pulled high in reset. BD pins include Port1, Port2, Port3, Port4, Port5 and Port6.
- Standard Input pins include XTAL1, EA, RESET and Ports 1, 2, 3, 4, 5, 6 when configured as inputs.
- All Bidirectional I/O pins when configured as Outputs (Push/Pull).
- Device is Static and should operate below 1 Hz, but only tested down to 4 MHz.
- Maximum I_{OL}/I_{OH} currents per pin will be characterized and published at a later date. Target values are ±10 mA.
- Typicals are based on limited number of samples and are not guaranteed. The values listed are at room temperature and V_{REF} = V_{CC} = 5.0V.
- V_{IH} max for Port0 is V_{REF} + 0.5V.
- Refer to "V_{OH2}/I_{OH2} Specification" errata # 1 in errata section of this datasheet.
- This specification is not tested in production and is based upon theoretical estimates and/or product characterization.

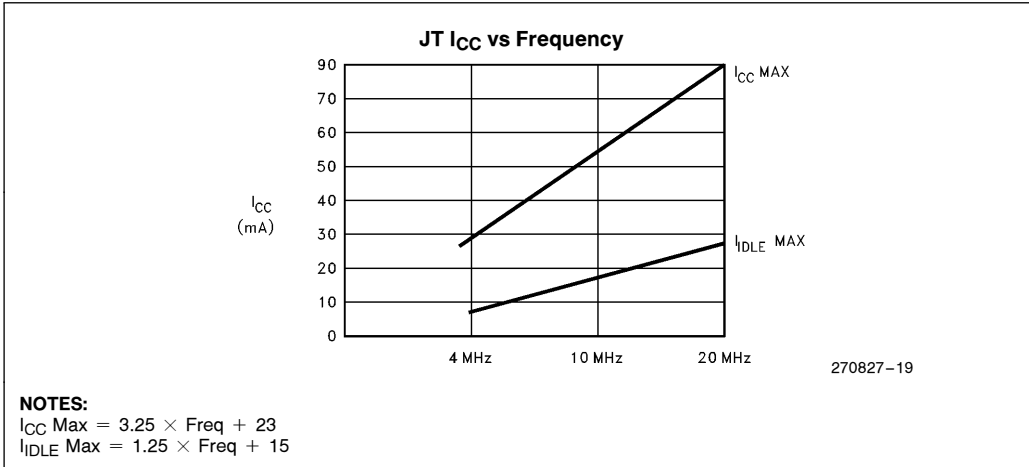
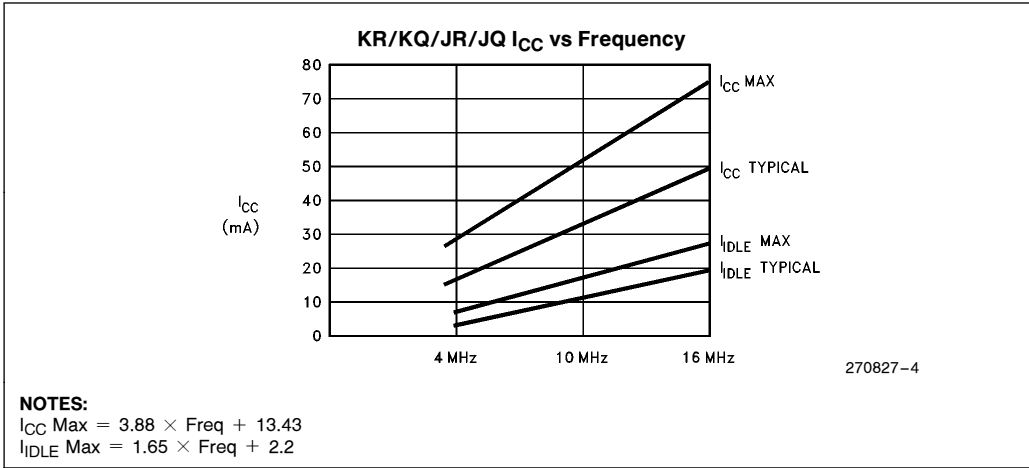

AC CHARACTERISTICS (Over Specified Operating Conditions)Test Conditions: Capacitance Load on All Pins = 100 pF, Rise and Fall Times = 10 ns, $F_{OSC} = 16$ MHz.**The system must meet these specifications to work with the 87C196KR/KQ/JV/JT/JR/JQ**

| Symbol | Parameter | Min | Max | Units |
|------------|--|----------------|------------------|-------------------|
| T_{AVYV} | Address Valid to READY Setup | | $2 T_{OSC} - 75$ | ns |
| T_{LLYV} | ALE Low to READY Setup | | $T_{OSC} - 70$ | ns |
| T_{YLYH} | Non READY Time | No Upper Limit | | ns |
| T_{CLYX} | READY Hold after CLKOUT Low | 0 | $T_{OSC} - 30$ | ns ⁽¹⁾ |
| T_{LLYX} | READY Hold after ALE Low | $T_{OSC} - 15$ | $2 T_{OSC} - 40$ | ns ⁽¹⁾ |
| T_{AVGV} | Address Valid to Buswidth Setup | | $2 T_{OSC} - 75$ | ns |
| T_{LLGV} | ALE Low to Buswidth Setup | | $T_{OSC} - 60$ | ns |
| T_{CLGX} | Buswidth Hold after CLKOUT Low | 0 | | ns |
| T_{AVDV} | Address Valid to Input Data Valid | | $3 T_{OSC} - 55$ | ns |
| T_{RLDV} | \overline{RD} Active to Input Data Valid | | $T_{OSC} - 22$ | ns |
| T_{CLDV} | CLKOUT Low to Input Data Valid | | $T_{OSC} - 50$ | ns |
| T_{RHDZ} | End of \overline{RD} to Input Data Float | | T_{OSC} | ns |
| T_{RXDX} | Data Hold after \overline{RD} Inactive | 0 | | ns |

NOTE:

1. If max is exceeded, additional wait states will occur.

The 87C196KR/KQ/JV/JT/JR/JQ will meet these specifications.

| Symbol | Parameter | Min | Max | Units |
|------------|--|----------------|----------------|--------------------|
| F_{XTAL} | Oscillator Frequency | 4.0 | 16.0 | MHz ⁽¹⁾ |
| T_{OSC} | Oscillator Period (1/ F_{xtal}) | 62.5 | 250 | ns |
| T_{XHCH} | XTAL1 High to CLKOUT High or Low | 20 | 110 | ns ⁽²⁾ |
| T_{CLCL} | CLKOUT Period | $2 T_{OSC}$ | | ns |
| T_{CHCL} | CLKOUT High Period | $T_{OSC} - 10$ | $T_{OSC} + 15$ | ns |
| T_{CLLH} | CLKOUT Falling Edge to ALE Rising | - 10 | 15 | ns |
| T_{LLCH} | ALE/ \overline{ADV} Falling Edge to CLKOUT Rising | - 20 | 15 | ns |
| T_{LHLH} | ALE/ \overline{ADV} Cycle Time | $4 T_{OSC}$ | | ns |
| T_{LHLL} | ALE/ \overline{ADV} High Period | $T_{OSC} - 10$ | $T_{OSC} + 10$ | ns |
| T_{AVLL} | Address Setup to ALE/ \overline{ADV} Falling Edge | $T_{OSC} - 15$ | | ns |
| T_{LLAX} | Address Hold after ALE/ \overline{ADV} Falling Edge | $T_{OSC} - 40$ | | ns |
| T_{LLRL} | ALE/ \overline{ADV} Falling Edge to \overline{RD} Falling Edge | $T_{OSC} - 30$ | | ns |



AC CHARACTERISTICS (Over Specified Operating Conditions) (Continued)

Test Conditions: Capacitance Load on All Pins = 100 pF, Rise and Fall Times = 10 ns, $F_{OSC} = 16$ MHz.

The 87C196KR/KQ/JV/JT/JR/JQ will meet these specifications.

| Symbol | Parameter | Min | Max | Units |
|------------|--|-------------------------------|----------------|-------------------|
| T_{RLCL} | \overline{RD} Low to CLKOUT Falling Edge | 4 | 30 | ns |
| T_{RLRH} | \overline{RD} Low Period | $T_{OSC} - 5$ | | ns |
| T_{RHLH} | \overline{RD} Rising Edge to ALE/ \overline{ADV} Rising Edge | T_{OSC} | $T_{OSC} + 25$ | ns ⁽³⁾ |
| T_{RLAZ} | \overline{RD} Low to Address Float | | 5 | ns ⁽⁵⁾ |
| T_{LLWL} | ALE/ \overline{ADV} Falling Edge to \overline{WR} Falling Edge | $T_{OSC} - 10$ | | ns |
| T_{CLWL} | CLKOUT Low to \overline{WR} Falling Edge | - 5 | 25 | ns |
| T_{QVWH} | Data Stable to \overline{WR} Rising Edge | $T_{OSC} - 23$ | | ns |
| T_{CHWH} | CLKOUT High to \overline{WR} Rising Edge | - 10 | 15 | ns |
| T_{WLWH} | \overline{WR} Low Period | $T_{OSC} - 20$ | | ns |
| T_{WHQX} | Data Hold after \overline{WR} Rising Edge | $T_{OSC} - 25$ | | ns |
| T_{WHLH} | \overline{WR} Rising Edge to ALE/ \overline{ADV} Rising Edge | $T_{OSC} - 10$ | $T_{OSC} + 15$ | ns ⁽³⁾ |
| T_{WHBX} | \overline{BHE} , INST Hold after \overline{WR} Rising Edge | $T_{OSC} - 10$ | | ns |
| T_{WHAX} | AD8-15 Hold after \overline{WR} Rising Edge | $T_{OSC} - 30$ ⁽⁴⁾ | | ns |
| T_{RHBX} | \overline{BHE} , INST Hold after \overline{RD} Rising Edge | $T_{OSC} - 10$ | | ns |
| T_{RHAX} | AD8-15 Hold after \overline{RD} Rising Edge | $T_{OSC} - 30$ ⁽⁴⁾ | | ns |

NOTES:

1. Testing performed at 4.0 MHz, however, the device is static by design and will typically operate below 1 Hz.
2. Typical specifications, not guaranteed.
3. Assuming back-to-back bus cycles.
4. 8-bit bus only.
5. T_{RLAZ} (max) = 5 ns by design.



System Bus Timing

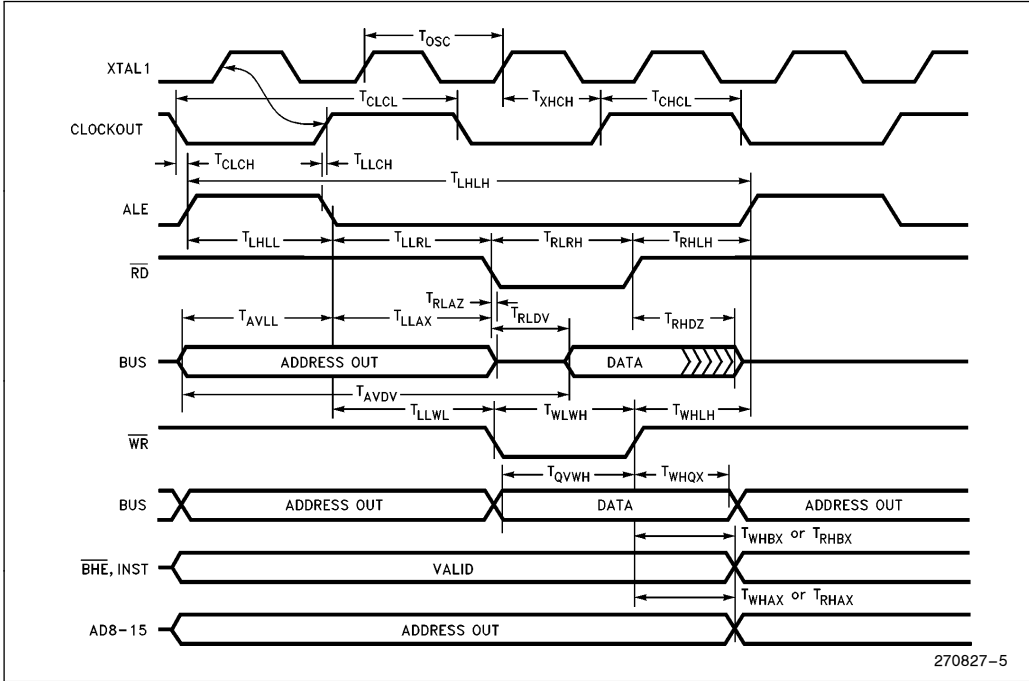

READY/BUSWIDTH TIMING

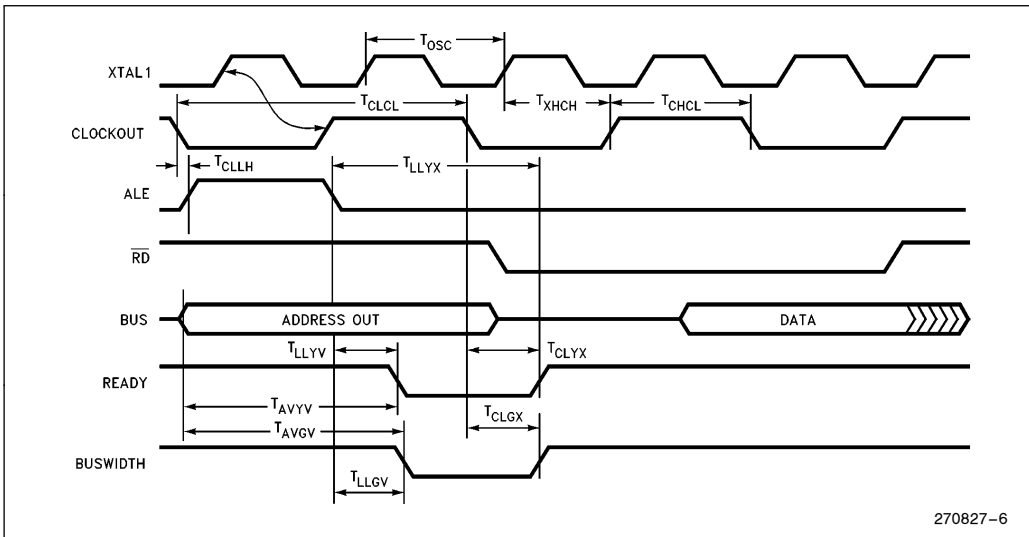

EXTERNAL CLOCK DRIVE

| Symbol | Parameter | Min | Max | Units |
|--------------|---------------------------------|----------------|----------------|-------|
| $1/T_{XLXL}$ | Oscillator Frequency | 4.0 | 16 | MHz |
| T_{XLXL} | Oscillator Period (T_{OSC}) | 62.5 | 250 | ns |
| T_{XHXX} | High Time | $0.35 T_{OSC}$ | $0.65 T_{OSC}$ | ns |
| T_{XLXX} | Low Time | $0.35 T_{OSC}$ | $0.65 T_{OSC}$ | ns |
| T_{XLXH} | Rise Time | | 10 | ns |
| T_{XHXL} | Fall Time | | 10 | ns |

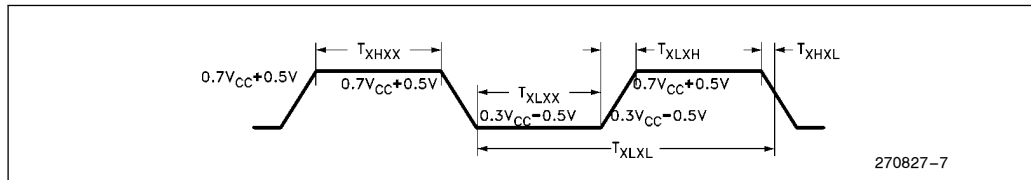
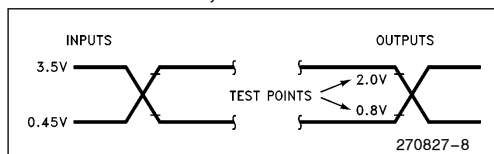
EXTERNAL CLOCK DRIVE WAVEFORMS

AC TESTING INPUT, OUTPUT WAVEFORMS

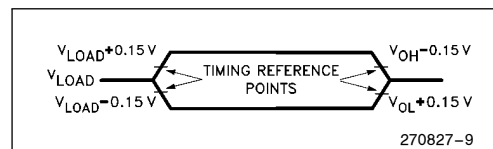
NOTE:

AC Testing Inputs are driven at 3.5V for a logic "1" and 0.45V for a logic "0". Timing measurements are made at 2.0V for a logic "1" and 0.8V for logic "0".

FLOAT WAVEFORMS

NOTE:

For timing purposes a port pin is no longer floating when a 150 mV change from load voltage occurs and begins to float when a 150 mV change from the loading V_{OH}/V_{OL} level occurs $I_{OL}/I_{OH} \leq 15$ mA.

THERMAL CHARACTERISTICS

| Device and Package | θ_{JA} | θ_{JC} |
|---------------------------------------|---------------|---------------|
| AN87C196KR/KQ (68-Lead PLCC) | 41°C/W | 14°C/W |
| AN87C196JV/JT/JR/JQ (52-Lead PLCC) | 42°C/W | 15°C/W |

NOTES:

- θ_{JA} = Thermal resistance between junction and the surrounding environment (ambient). Measurements are taken 1 ft. away from case in air flow environment.
 θ_{JC} = Thermal resistance between junction and package surface (case).
- All values of θ_{JA} and θ_{JC} may fluctuate depending on the environment (with or without airflow, and how much airflow) and device power dissipation at temperature of operation. Typical variations are $\pm 2^\circ\text{C}/\text{W}$.
- Values listed are at a maximum power dissipation of 0.50W.

EXPLANATION OF AC SYMBOLS

Each symbol is two pairs of letters prefixed by “t” for time. The characters in a pair indicate a signal and its condition, respectively. Symbols represent the time between the two signal/condition points.

Conditions:

H— High
L— Low
V— Valid
X— No Longer Valid
Z— Floating

Signals:

A— Address
B— \overline{BHE}
C— CLKOUT
D— DATA
G— Buswidth
H— \overline{HOLD}

HA— \overline{HLDA}
L— ALE/ \overline{ADV}
R— \overline{RD}
W— $\overline{WR}/\overline{WRH}/\overline{WRI}$
X— XTAL1
Y— READY

EPROM SPECIFICATIONS

AC EPROM PROGRAMMING CHARACTERISTICS

Operating Conditions: Load Capacitance = 150 pF; $T_C = 25^\circ\text{C} \pm 5^\circ\text{C}$, $V_{REF} = 5.0\text{V} \pm 0.5\text{V}$, V_{SS} , $ANGND = 0\text{V}$, $V_{PP} = 12.5\text{V} \pm 0.25\text{V}$; $\overline{EA} = 12.5\text{V} \pm 0.25\text{V}$; $F_{OSC} = 5.0\text{ MHz}$

| Symbol | Parameter | Min | Max | Units |
|------------|--|------|-----|-----------|
| T_{AVLL} | Address Setup Time | 0 | | T_{OSC} |
| T_{LLAX} | Address Hold Time | 100 | | T_{OSC} |
| T_{DVPL} | Data Setup Time | 0 | | T_{OSC} |
| T_{PLDX} | Data Hold Time | 400 | | T_{OSC} |
| T_{LLH} | \overline{PALE} Pulse Width | 50 | | T_{OSC} |
| T_{PLPH} | \overline{PROG} Pulse Width ⁽³⁾ | 50 | | T_{OSC} |
| T_{LHPL} | \overline{PALE} High to \overline{PROG} Low | 220 | | T_{OSC} |
| T_{PHLL} | \overline{PROG} High to Next \overline{PALE} Low | 220 | | T_{OSC} |
| T_{PHDX} | Word Dump Hold Time | | 50 | T_{OSC} |
| T_{PHPL} | \overline{PROG} High to Next \overline{PROG} Low | 220 | | T_{OSC} |
| T_{PLDV} | \overline{PROG} Low to Word Dump Valid | | 50 | T_{OSC} |
| T_{SHLL} | \overline{RESET} High to First \overline{PALE} Low | 1100 | | T_{OSC} |
| T_{PHIL} | \overline{PROG} High to \overline{AINC} Low | 0 | | T_{OSC} |
| T_{ILIH} | \overline{AINC} Pulse Width | 240 | | T_{OSC} |
| T_{ILVH} | \overline{PVER} Hold after \overline{AINC} Low | 50 | | T_{OSC} |
| T_{ILPL} | \overline{AINC} Low to \overline{PROG} Low | 170 | | T_{OSC} |
| T_{PHVL} | \overline{PROG} High to \overline{PVER} Valid | | 220 | T_{OSC} |

NOTES:

- Run time programming is done with $F_{OSC} = 6.0\text{ MHz}$ to 10.0 MHz , V_{CC} , V_{PD} , $V_{REF} = 5\text{V} \pm 0.5\text{V}$, $T_C = 25^\circ\text{C} \pm 5^\circ\text{C}$ and $V_{PP} = 12.5\text{V} \pm 0.25\text{V}$. For run-time programming over a full operating range, contact factory.
- Programming Specifications are not tested, but guaranteed by design.
- This specification is for the word dump mode. For programming pulses use $300 T_{OSC} + 100 \mu\text{s}$.

DC EPROM PROGRAMMING CHARACTERISTICS

| Symbol | Parameter | Min | Max | Units |
|----------|-------------------------------------|-----|-----|-------|
| I_{PP} | V_{PP} Programming Supply Current | | 100 | mA |

NOTE:

V_{PP} must be within 1V of V_{CC} while $V_{CC} < 4.5\text{V}$. V_{PP} must not have a low impedance path to ground or V_{SS} while $V_{CC} > 4.5\text{V}$.

EPROM PROGRAMMING WAVEFORMS

SLAVE PROGRAMMING MODE DATA PROGRAM MODE WITH SINGLE PROGRAM PULSE

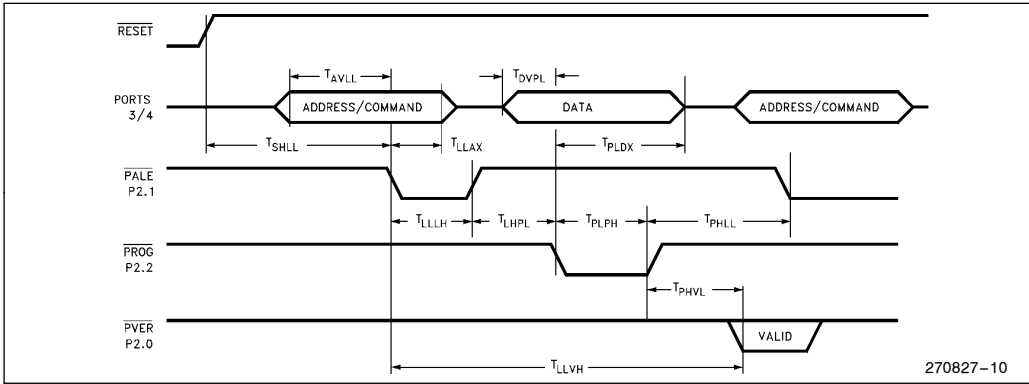

SLAVE PROGRAMMING MODE IN WORD DUMP OR DATA VERIFY MODE WITH AUTO INCREMENT

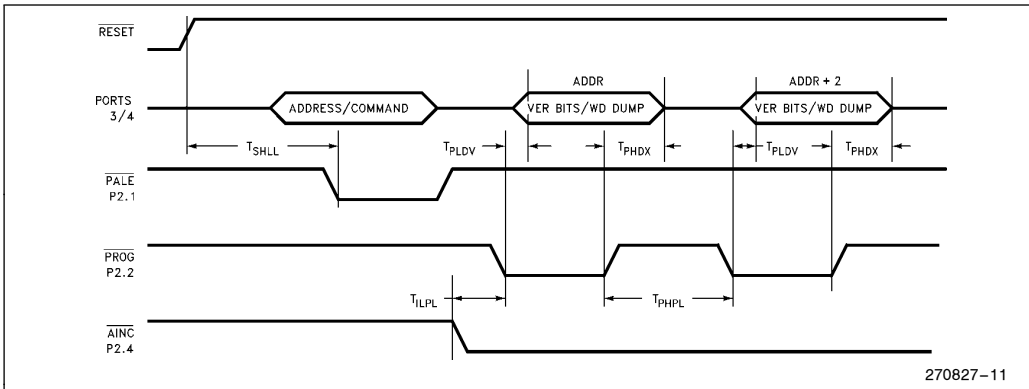

SLAVE PROGRAMMING MODE TIMING IN DATA PROGRAM MODE WITH REPEATED PROG PULSE AND AUTO INCREMENT

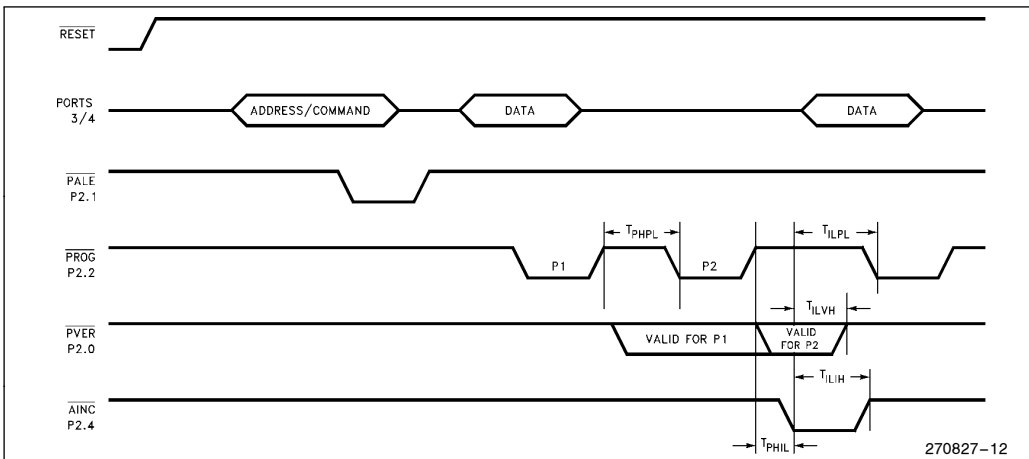

A TO D CONVERTER SPECIFICATIONS

The speed of the A/D converter in the 10-bit or 8-bit modes can be adjusted by setting the AD_TIME special function register to the appropriate value. The AD_TIME register only programs the speed at which the conversions are performed, not the speed at which it can convert correctly.

The converter is ratiometric, so absolute accuracy is dependent on the accuracy and stability of V_{REF} .

V_{REF} must not exceed V_{CC} by more than 0.5V since it supplies both the resistor ladder and the digital portion of the converter and input port pins.

For testing purposes, after a conversion is started, the device is placed in the IDLE mode until the conversion is complete. Testing is performed at $V_{REF} = 5.12V$ and 16 MHz operating frequency.

There is an AD_TEST register that allows for conversion on ANGND and V_{REF} as well as zero offset adjustment. The absolute error listed is without doing any adjustments.

A/D OPERATING CONDITIONS⁽¹⁾

| Symbol | Description | Min | Max | Units |
|------------|--------------------------------|------|------------------------|------------------------|
| T_A | Automotive Ambient Temperature | -40 | +125 | °C |
| V_{CC} | Digital Supply Voltage | 4.50 | 5.50 | V |
| V_{REF} | Analog Supply Voltage | 4.50 | 5.50 ^(2, 3) | V |
| T_{SAM} | Sample Time | 2.0 | | μs ⁽⁴⁾ |
| T_{CONV} | Conversion Time | 16.5 | 19.5 | μs ⁽⁴⁾ |
| F_{OSC} | Oscillator Frequency | 4 | 16 | MHz |

NOTES:

1. ANGND and V_{SS} should nominally be at the same potential.
2. V_{REF} must not exceed V_{CC} by more than +0.5V.
3. Testing is performed at $V_{REF} = 5.12V$.
4. The value of AD_TIME must be selected to meet these specifications.

| Parameter | Typical ^{*(1)} | Min | Max | Units ^{**} |
|--|-------------------------|------------|----------------------------|--|
| Resolution | | 1024 10 | 1024 10 | Level Bits |
| Absolute Error | | 0 | -3 +3 | LSBs |
| Full Scale Error | ± 2 | | | LSBs |
| Zero Offset Error | ± 2 | | | LSBs |
| Non-Linearity | | | ± 3 | LSBs |
| Differential Non-Linearity | | > -0.5 | +0.5 | LSBs |
| Channel-to-Channel Matching | | 0 | ± 1 | LSBs |
| Repeatability | ± 0.25 | 0 | | LSBs ⁽¹⁾ |
| Temperature Coefficients: Offset Fullscale Differential Non-Linearity | 0.009 0.009 0.009 | | | LSB/C ⁽¹⁾ LSB/C ⁽¹⁾ LSB/C ⁽¹⁾ |
| Off Isolation | | -60 | | dB ^(1, 2, 3) |
| Feedthrough | -60 | | | dB ^(1, 2) |
| V_{CC} Power Supply Rejection | -60 | | | dB ^(1, 2) |
| Input Resistance | | 750 | 1.2K | Ω ⁽¹⁾ |
| DC Input Leakage | | 0 | ± 1 JT/JV = ± 2 | μA |

NOTES:

- *These values are expected for most parts at 25°C but are not tested or guaranteed.
 **An "LSB", as used here, has a value of approximately 5 mV. (See Automotive Handbook for A/D glossary of terms).
1. These values are not tested in production and are based on theoretical estimates and/or laboratory test.
 2. DC to 100 KHz
 3. Multiplexer Break-Before-Make Guaranteed.

HOLD/HLDA Timings

| Symbol | Description | Min | Max | Units | Notes |
|-------------|--|-----|-----|-------|----------|
| T_{HVCH} | HOLD Setup | 65 | | ns | (Note 1) |
| T_{CLHAL} | CLKOUT Low to HLDA Low | -15 | 15 | ns | |
| T_{CLBRL} | CLKOUT Low to BREQ Low | -15 | 15 | ns | |
| T_{AZHAL} | HLDA Low to Address Float | | 25 | ns | |
| T_{BZHAL} | HLDA Low to \overline{BHE} , \overline{INST} , \overline{RD} , \overline{WR} Weakly Driven | | 25 | ns | |
| T_{CLHAH} | CLKOUT Low to HLDA High | -15 | 15 | ns | |
| T_{CLBRH} | CLKOUT Low to BREQ High | -15 | 15 | ns | |
| T_{HAHAX} | HLDA High to Address Valid | -15 | | ns | |
| T_{HAHBV} | HLDA High to \overline{BHE} , \overline{INST} , \overline{RD} , \overline{WR} Valid | -10 | | ns | |
| T_{CLLH} | CLKOUT Low to ALE High | -10 | 15 | ns | |

NOTE:

1. To guarantee recognition at next clock.

DC SPECIFICATIONS IN HOLD

| Parameter | Min | Max | Units |
|--|-----|------|---------------------------------|
| Weak Pullups on \overline{ADV} , \overline{RD} , \overline{WR} , \overline{WRL} , \overline{BHE} | 50K | 250K | $V_{CC} = 5.5V, V_{IN} = 0.45V$ |
| Weak Pulldowns on ALE, \overline{INST} | 10K | 50K | $V_{CC} = 5.5V, V_{IN} = 2.4$ |

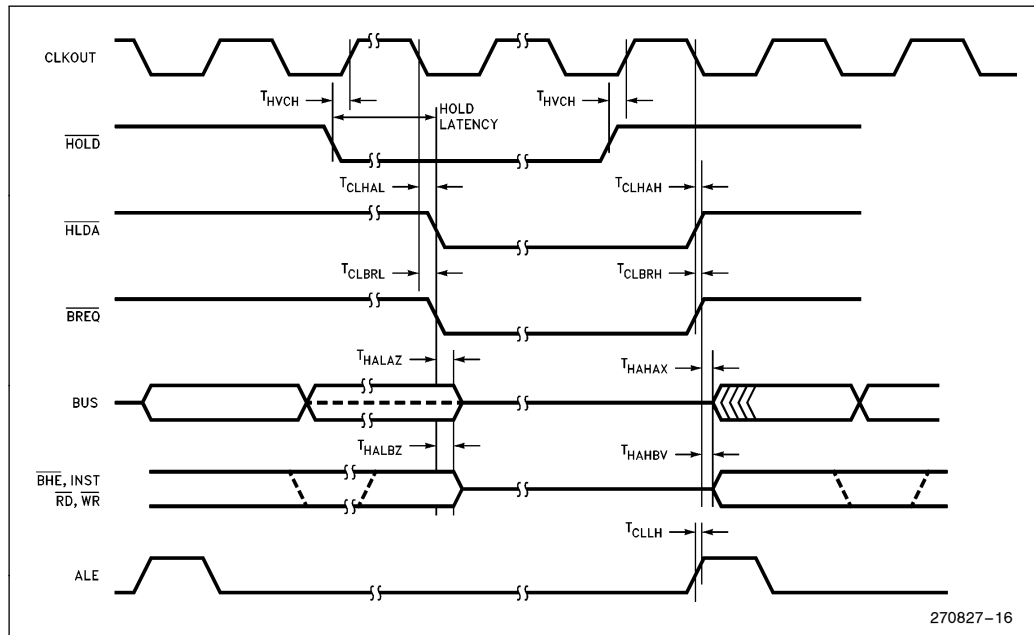

AC CHARACTERISTICS—SLAVE PORT

SLAVE PORT WAVEFORM—(SLPL = 0)

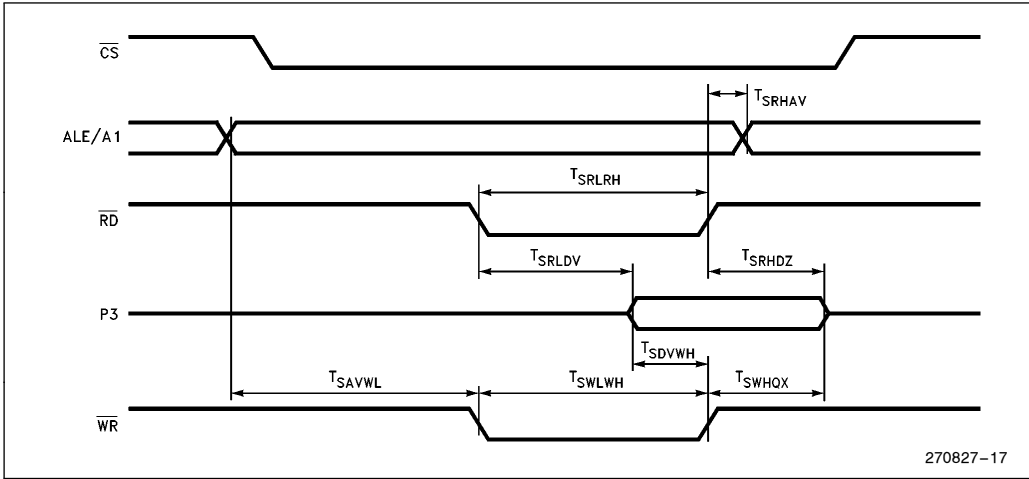

SLAVE PORT TIMING—(SLPL = 0)(1, 2, 3)

| Symbol | Parameter | Min | Max | Units |
|--------------------|--|------------------|-----|-------|
| T _{SAVWL} | Address Valid to \overline{WR} Low | 50 | | ns |
| T _{SRHAV} | \overline{RD} High to Address Valid | 60 | | ns |
| T _{SRLRH} | \overline{RD} Low Period | T _{OSC} | | ns |
| T _{SWLWH} | \overline{WR} Low Period | T _{OSC} | | ns |
| T _{SRLDV} | \overline{RD} Low to Output Data Valid | | 60 | ns |
| T _{SDVWH} | Input Data Setup to \overline{WR} High | 20 | | ns |
| T _{SWHQX} | \overline{WR} High to Data Invalid | 30 | | ns |
| T _{SRHDZ} | \overline{RD} High to Data Float | 15 | | ns |

NOTES:

1. Test Conditions: F_{OSC} = 16 MHz, T_{OSC} = 60 ns. Rise/Fall Time = 10 ns. Capacitive Pin Load = 100 pF.
2. These values are not tested in production, and are based upon theoretical estimates and/or laboratory tests.
3. Specifications above are advanced information and are subject to change.





52-LEAD DEVICES

Intel offers 52-lead versions of the 87C196KR device: the 87C196JV/JT/JR/JQ devices. The first samples and production units use the 87C196KR die and bond it out in a 52-lead package.

It is important to point out some functionality differences because of future devices or to remain software consistent with the 68-lead device. Because of the absence of pins on the 52-lead device some functions are not supported.

52-Lead Unsupported Functions:

- Analog Channels 0 and 1
- INST Pin Functionality
- SLPINT Pin Support
- HLD/HLDA Functionality
- External Clocking/Direction of Timer1
- WRH or BHE Functions
- Dynamic Buswidth
- Dynamic Wait State Control

The following is a list of recommended practices when using the 52-lead device:

- (1) **External Memory.** Use an 8-bit bus mode only. There is neither a WRH or BUSWIDTH pin. The bus cannot dynamically switch from 8- to 16-bit or vice versa. Set the CCB bytes to an 8-bit only mode, using WR function only.
- (2) **Wait State Control.** Use the CCB bytes to configure the maximum number of wait states. If the READY pin is selected to be a system function, the device will lockup waiting for READY. If the READY pin is configured as LSIO (default after RESET), the internal logic will receive a logic "0" level and insert the CCB defined number of wait states in the bus cycle. DON'T USE IRC = "111".
- (3) **NMI Support.** The NMI is not bonded out. Make the NMI vector at location 203Eh vector to a Return instruction. This is for glitch safety protection only.
- (4) **Auto-Programming Mode.** The 52-lead device will ONLY support the 16-bit zero wait state bus during auto-programming.
- (5) **EPA4 through EPA7.** Since the JR and JQ devices use the KR silicon, these functions are in the device, just not bonded out. A programmer can use these as compare only channels or for other functions like software timer, start an A/D conversion, or reset timers.

(6) **Slave Port Support.** The Slave port cannot be easily used on 52-lead devices due to P5.4/SLPINT and P5.1/SLPCS not being bonded-out.

(7) **Port Functions.** Some port pins have been removed. P5.7, P5.6, P5.5, P5.1, P6.2, P6.3, P1.4 through P1.7, P2.3, P2.5, P0.0 and P0.1. The PxREG, PxSSEL, and PxlO registers can still be updated and read. The programmer should not use the corresponding bits associated with the removed port pins to conditionally branch in software. Treat these bits as RESERVED.

Additionally, these port pins should be setup internally by software as follows:

1. Written to PxREG as "1" or "0".
2. Configured as Push/Pull, PxlO as "0".
3. Configured as LSIO.

This configuration will effectively strap the pin either high or low. *DO NOT Configure as Open Drain output "1", or as an Input pin. This device is CMOS.*

87C196KR/KQ/JV/JT/JR/JQ ERRATA

1. VOH2/IOH2 Specification (Note C)

In the DC Characteristics section of this data-sheet, VOH2 indicates the strength of the internal weak pullups that are active during and after reset until the user writes to the PxMODE register. C-step devices do not meet this specification. The new specification for C-step devices is VOH2 (min) = VCC - 1V at IOH2 = -6 μA. Note that JR/JQ D-step devices are not affected by this errata and meet the published specification.

2. 1B00h-1BDFh External Addressing (Notes C, D)

Affected devices cannot access external memory locations 1B00h-1BDFh. A bus cycle does not occur when these addresses are accessed. If attempting to read from 1B00h-1BDFh a value of FFh is returned even though a read cycle is not generated. Writing to these locations will not generate an external bus cycle either. This errata has been corrected on JV and JT devices.

3. Port3 Push-Pull Operation (Note C)

If Port3 is operating as a push-pull LSIO (Low-Speed I/O) port and an address/data bus cycle occurs, Port3 will continue to drive the address/data bus with its LSIO data during the bus cycle. It is rather unlikely that this errata would affect an

application because the application would have to use Port3 for both LSI0 and as an external addr/data bus. If an application uses external memory, Port3 should not be selected as push-pull LSI0.

NOTES:

- “C” = Present on C-step devices
- “D” = Present on D-step devices
- “V” = Present on JV A-step devices
- “T” = Present on JT A-step devices

Devices can be identified by a special mark following the eight-digit FPO number on the top of the package. The following chart specifies what these markings are for various device steppings:

| Device | Topside Marking |
|---------------|-----------------|
| KR, KQ C-step | “C” |
| JR, JQ D-step | “D” |
| JV, JT A-step | “A” |

87C196KR/KQ/JV/JT/JR/JQ DESIGN CONSIDERATIONS

1. EPA Timer RESET/Write Conflict

If the user writes to the EPA timer at the same time that the timer is reset, it is indeterminate which will take precedence. Users should not write to a timer if using EPA signals to reset it.

2. Valid Time Matches

The timer must increment/decrement to the compare value for a match to occur. A match does not occur if the timer is loaded with a value equal to an EPA compare value. Matches also do not occur if a timer is reset and 0 is the EPA compare value.

3. P6__PIN.4--7 Not Updated Immediately

Values written to P6__REG are temporarily held in a buffer. If P6__MODE is cleared, the buffer is loaded into P6__REG.x. If P6__MODE is set, the value stays in the buffer and is loaded into P6__REG.x when P6__MODE.x is cleared. Since reading P6__REG returns the current value in P6__REG and not the buffer, changes to P6__REG cannot be read until/unless P6__MODE.x is cleared.

4. Write Cycle during Reset

If RESET occurs during a write cycle, the contents of the external memory device may be corrupted.

5. Indirect Shift Instruction

The upper 3 bits of the byte register holding the shift count are not masked completely. If the shift count register has the value $32 \times n$, where $n = 1, 3, 5, \text{ or } 7$, the operand will be shifted 32 times. This should have resulted in no shift taking place.

6. P2.7 (CLKOUT)

P2.7 (CLKOUT) does not operate in open drain mode.

7. CLKOUT

The CLKOUT signal is active on P2.7 during RESET for the KR, KQ, JV, JT, JR and JQ devices. Note that CLKOUT is not active on P2.7 in RESET for the KT.

8. EPA Overruns

EPA “lock-up” can occur if overruns are not handled correctly, refer to Intel Techbit #DB0459 “Understanding EPA Capture Overruns”, dated 12-9-93. Applies to EPA channels with interrupts and overruns enabled (ON/RT bit in EPA__CONTROL register set to “1”).

9. Indirect Addressing with Auto-Increment

For the special case of a pointer pointing to itself using auto-increment, an incorrect access of the incremented pointer address will occur instead of an access to the original pointer address. All other indirect auto-increment accesses will not be affected. Please refer to Techbit #MC0593.

Incorrect sequence:

```
ld ax, #ax ; Results in ax being
ldb bx, [ax]+ ; incremented by 1 and the
                contents of the address
                pointed to by ax + 1 to be
                loaded into bx.
```

Correct sequence:

```
ld ax, #bx ; where ax ≠ bx. Results in
ldb cx, [ax]+ ; the contents of the address
                pointed to by ax to be
                loaded into bx and ax
                incremented by 1.
```

10. JV Additional Register RAM

The 8XC196JV has a total of 1.5 Kbytes of register RAM. The RAM is located in two memory ranges: 0000h–03FFh and 1C00h–1DFFh.

87C196JR/JQ C-step to JR/JQ D-step –or– JV/JT A-step DESIGN CONSIDERATIONS

This section documents differences between the 87C197JV A-step (JV-A)/87C196JT A-step (JT-A)/



87C196JR D-step (JR-D) and the 87C196JR C-step (JR-C). For a list of design considerations between 68-lead and 52-lead devices, please refer to the 52-lead Device Design Considerations section of this datasheet. Since the 87C196JV/JT/JQ are simply memory scalars of the 87C196JR, the term "JR" in this section will refer to JV, JT, JR and JQ versions of the device unless otherwise noted.

The JR-C is simply a 87C196KR C-step (KR-C) device packaged within a 52-lead package. This reduction in pin count necessitated not bonding-out certain pins of the KR-C device. The fact that these "removed pins" were still present on the device but not available to the outside world allowed the programmer to take advantage of some of the 68-lead KR features.

The JR-D is a fully-optimized 52-lead device based on the 87C196KR C-step device. The KR-C design data base was used to assure that the JR-D would be fully compatible with the KR-C, JR-C and other Kx family members. The main differences between the JR-D and the JR-C is that several of the unused (not bonded-out) functions on the JR-C were removed altogether on the JR-D.

Following is a list of differences between the JR-C and the JR-D:

1. Port3 Push-Pull Operation

It was discovered on JR-C that if Port3 is selected for push-pull operation (P34_DRV register) during low speed I/O (LSIO), the port was driving data when the system bus was attempting to input data. It is rather unlikely that this errata would affect an application because the application would have to use Port3 for both LSIO and as an external addr/data bus. Nonetheless, this errata was corrected on the JR-D.

2. VOH2 Strengthened

The DC Characteristics section of the Automotive KR datasheet contains a parameter, VOH2 (Output High Voltage in RESET (BD ports)), which is specified at VCC-1V min at IOH2 = -15 μA. This specification indicates the strength of the internal weak pull-ups that are active during and after reset. These weak pull-ups stay active until the user writes to PxMODE (previously known as PxSSEL) and configures the port pin as desired.

These pull-ups do not meet this VOH2 spec on the JR-C. The weak pull-ups on specified JR-D ports have been enhanced to meet the published specification of IOH2 = -15 μA.

3. ONCE Mode

ONCE mode is entered by holding a single pin low on the rising edge of RESET#. On the KR, this pin is P5.4/SLPINT. The JR-C does not support ONCE mode since P5.4/SLPINT (ONCE mode entry pin) is not bonded-out on these devices. To provide ONCE mode on the JR-D, the ONCE mode entry function was moved from P5.4/SLPINT to P2.6/HLDA. This will allow the JR-D to enter ONCE mode using P2.6 instead of removed pin P5.4.

4. Port0

On the JR-C, P0.0 and P0.1 are not bonded out. However, these inputs are present in the device and reading them will provide an indeterminate result.

On the JR-D, the analog inputs for these two channels at the multiplexer are tied to VREF. Therefore, initiating an analog conversion on ACH0 or ACH1 will result in a value equal to full scale (3FFh). On the JR-D, the digital inputs for these two channels are tied to ground, therefore reading P0.0 or P0.1 will result in a digital "0".

5. Port1

On the JR-C, P1.4, P1.5, P1.6 and P1.7 are not bonded out but are present internally on the device. This allows the programmer to write to the port registers and clear, set or read the pin even though it is not available to the outside world. However, to maintain compatibility with D-step and future devices, it is recommended that the corresponding bits associated with the removed pins NOT be used to conditionally branch in software. These bits should be treated as reserved.

On the JR-D, unused port logic for these four port pins has been removed from the device and is not available to the programmer. Corresponding bits in the port registers have been "hard-wired" to provide the following results when read:

| Register Bits | | When Read |
|---------------|---------------|-----------|
| P1_PIN.x | (x = 4,5,6,7) | 1 |
| P1_REG.x | (x = 4,5,6,7) | 1 |
| P1_DIR.x | (x = 4,5,6,7) | 1 |
| P1_MODE.x | (x = 4,5,6,7) | 0 |

Writing to these bits will have no effect.

6. Port2

On the JR-C, P2.3 and P2.5 are not bonded out but are present internally on the device. This allows the programmer to write to the port registers and clear, set or read the pin even though it is not available to the outside world. However, to maintain compatibility with D-step and future devices, it is recommended that the corresponding bits associated with the removed pins not be used to conditionally branch in software. These bits should be treated as reserved.

On the JR-D, unused port logic for these two port pins has been removed from the device and is not available to the programmer. Corresponding bits in the port registers have been “hardwired” to provide the following results when read:

| Register Bits | | When Read |
|---------------|-----------|-----------|
| P2__PIN.x | (x = 3,5) | 1 |
| P2__REG.x | (x = 3,5) | 1 |
| P2__DIR.x | (x = 3,5) | 1 |
| P2__MODE.x | (x = 3,5) | 0 |

Writing to these bits will have no effect.

7. Port5

On the JR-C, P5.1, P5.4, P5.5, P5.6 and P5.7 are not bonded out but are present internally on the device. This allows the programmer to write to the port registers and clear, set or read the pin even though it is not available to the outside world. However, to maintain compatibility with D-step and future devices, it is recommended that the corresponding bits associated with the removed pins not be used to conditionally branch in software. These bits should be treated as reserved.

On the JR-D, unused port logic for these five port pins has been removed from the device and is not available to the programmer. Corresponding bits in the port registers have been “hardwired” to provide the following results when read:

| Register Bits | | When Read |
|---------------|-------------------|-----------|
| P5__PIN.x | (x = 1,4,5,6,7) | 1 |
| P5__REG.x | (x = 1,4,5,6,7) | 1 |
| P5__DIR.x | (x = 1,4,5,6,7) | 1 |
| P5__MODE.x | (x = 1,4,6) | 0 |
| P5__MODE.x | (x = 5) (EA# = 0) | 1 |
| P5__MODE.x | (x = 5) (EA# = 1) | 0 |
| P5__MODE.x | (x = 7) | 1 |

Writing to these bits will have no effect.

8. Port6

On the JR-C, P6.2 and P6.3 are not bonded out but are present internally on the device. This allows the programmer to write to the port registers and clear, set or read the pin even though it is not available to the outside world. However, to maintain compatibility with D-step and future devices, it is recommended that the corresponding bits associated with the removed pins not be used to conditionally branch in software. These bits should be treated as reserved.

On the JR-D, unused port logic for these two port pins has been removed from the device and is not available to the programmer. Corresponding bits in the port registers have been “hardwired” to provide the following results when read:

| Register Bits | | When Read |
|---------------|-----------|-----------|
| P6__PIN.x | (x = 2,3) | 1 |
| P6__REG.x | (x = 2,3) | 1 |
| P6__DIR.x | (x = 2,3) | 1 |
| P6__MODE.x | (x = 2,3) | 0 |

Writing to these bits will have no effect.

9. 8XC196JQ Internal to External Memory Roll-over Point

8XC196JQ devices are simply 8XC196JR devices with less memory. Both the JQ-C and JQ-D are fabricated from the JR-C and JR-D respectively. The difference between JQ and JR devices is that memory locations beyond the supported boundaries on the JQ are not tested in production and should not be used. Any software which relies upon reading or writing these locations may not function correctly. Following are the supported memory maps for these devices:



| | JQ C and D-Step | JR C and D-Step |
|---------------------|-----------------|-----------------|
| Register RAM | 18h to 17Fh | 18h to 1FFh |
| Internal (Code) RAM | 400h to 47Fh | 400h to 4FFh |
| Internal ROM/EPROM | 2000h to 4FFFh | 2000h to 5FFFh |

It is important to note that the internal to external memory roll-over point for both the JR and JQ devices is the same (6000h and above goes external). Two guidelines the programmer should follow to insure no problems are encountered when using JQ devices are:

- For JQ devices, the program must contain a jump to a location greater than 5FFFh before the 12K boundary (4FFFh) is reached. This is necessary only if greater than 12K of program memory is required with a JQ device and portions of the program execute from internal ROM/EPROM.
- For JQ devices with EA# tied to ground, use only internal program memory from 2000h to 4FFFh. Do not use the unsupported locations from 5000h to 5FFFh.

10. EPA Channels 4 through 7

The JR C-step device is simply a 68-lead KR-C device packaged in a 52-lead package. The reduced pin-out is achieved by not bonding-out the unsupported pins. EPA4–EPA7 are among these pins that are not bonded-out. The fact that EPA4–EPA7 are still present allows the programmer to use these channels as software timers, to start A/D conversions, reset timers, etc. All of the port pin logic is still present and it is possible to use the EPA to toggle these pins internally. Please refer to the 52-Lead Device section in this datasheet for further information.

On the JR D-step, the EPA4–EPA7 logic has NOT been removed from the device. This allows the programmer to still use these channels (as on the C-step) for software timers, etc. The only difference is that the associated port pin logic has been removed and does not exist internally. To maintain C-step to D-step compatibility, programmers should make sure that their software does not rely upon the removed pins.

DATASHEET REVISION HISTORY

This is the -006 version of the 87C196KR Datasheet. The following differences exist between the -005 version and the -006 version:

- The 87C196JV datasheet status has been moved from “Product Preview” to that of “no marking.”

- A “by design” note was added to the T_{RLAZ} specification.
- In the Design Considerations section, the #7. CLKOUT design consideration was corrected.
- Only the two most current revision histories of this datasheet were retained in the datasheet revision history section.

The following differences exist between the -004 version and the -005 version:

- The 87C196JT and 87C196JV 16 MHz devices were added to the list of products covered by this datasheet. The 87C196JT and 87C196JV are simply higher memory versions of the 87C196JR device. For 20 MHz datasheets of these devices, please refer to the following datasheets:
 - 20 MHz 87C196JT: order # 272529-001
 - 20 MHz 87C196JV: order # 272580-001
- The status of the datasheet has been moved from “Advanced Information” to that of no-marking. Datasheets with no markings reflect specifications that have reached full production status. Although the 87C196JV device is included within this datasheet, its specifications are actually at the design phase of development. Do not finalize a design with this information. Revised information will be published when the 87C196JV device becomes available.
- The title of the datasheet as well as the features and design considerations list has been revised to include the 87C196JT and 87C196JV devices.
- Notes were added as appropriate to call out where 87C196JV specifications are expected to differ from those of other products listed within this datasheet. Specifications which are expected to differ are I_{CC} , I_{CC1} , I_{IDLE} , and I_{L1} and DC Input Leakage on A/D channels.
- The V_{OH2} (min) specification was supplemented with more comprehensive I_{OH2} (min/max) specifications.
- A V_{OL3} (RESET pin only) specification was added to indicate the strength of the RESET pull-down device.
- All 87C196KR A-step errata was removed from the Errata section of this datasheet.
- For the JT, the DC input leakage (max), as specified in the previous JT datasheet (272374-002), has been corrected to 2 μ A to match the I_{L1} specification of 2 μ A. These specifications both specify the same parameter.
- CerQuad package references have been removed.