

### ■ Features

- On chip Hall sensor
- Rotor-locked shutdown
- Automatically restart
- Rotor-state detection (RD) output
- Built-in Zener protection for output driver
- Operating voltage: 10V~20 V, driver start up: 8V (minimum)
- Output current:  $I_{O(AVE)} = 300 \text{ mA}$
- Package: SIP-5L, SOT89-5L

### ■ General Description

AH283 is a monolithic fan motor controller with Hall sensor's capability. It contains two complementary open-collector transistors for motor's coil driving, automatic lock current shutdown, and recovery protections. In addition, rotor-state detection (RD) output is for Rotor-state detection.

To avoid coil burning, rotor-lock shutdown detection circuit shut down the output driver if the rotor is blocked and then the automatic recovery circuit will try to restart the motor. This function repeats while the rotor is blocked. Until the blocking is removed, the motor recovers running normally.

### ■ Pin Configuration

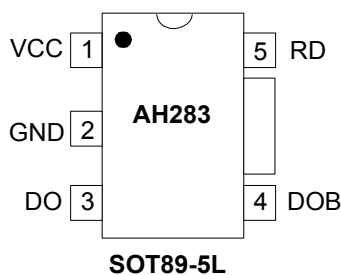
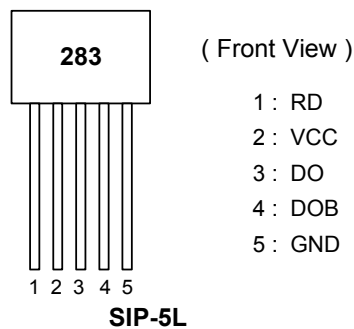

### ■ Pin Descriptions

Symbol	Description
RD	Rotor-state detection
VCC	Input power
DO	Output pin
DOB	Output pin
GND	Ground

### ■ Ordering Information

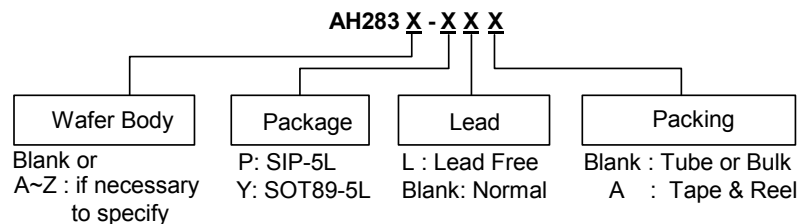

### ■ Block Diagram (SIP5)

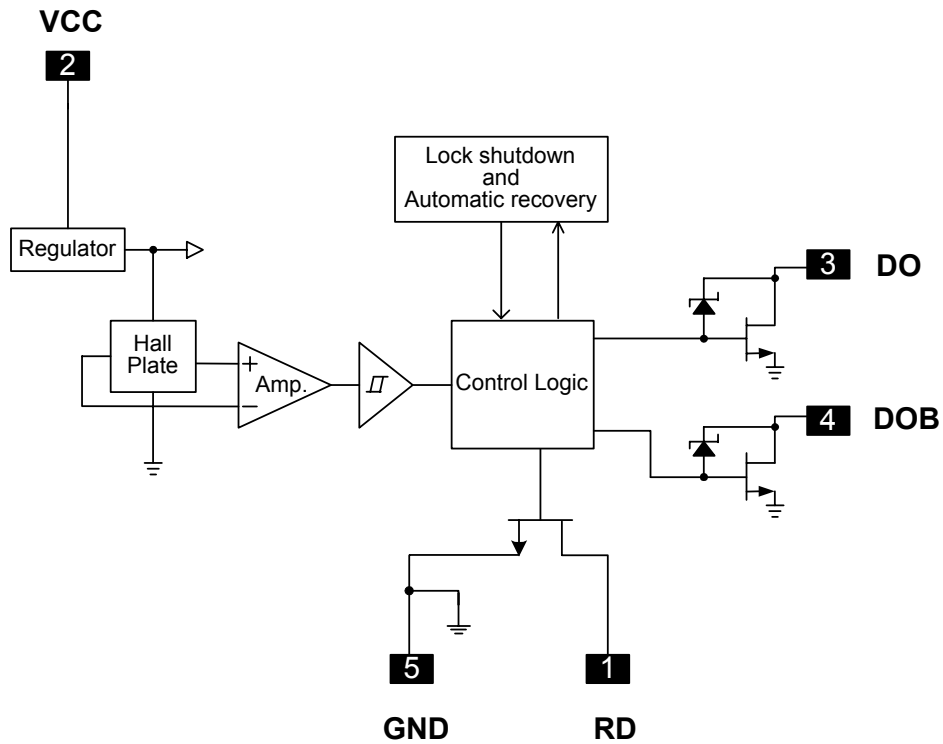

### ■ Typical Application Circuit

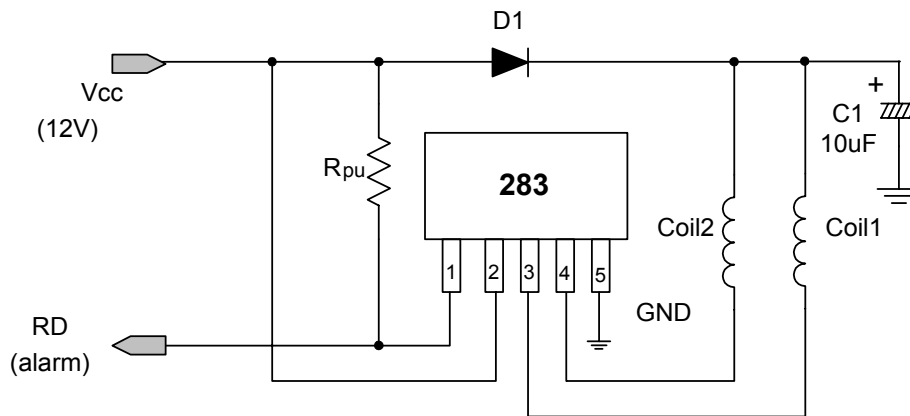

12V DC Brush-less Fan with RD output function

**Hall-Effect Smart Fan Motor Controller**
**■ Absolute Maximum Ratings** ( $T_a = 25^\circ\text{C}$ )

Characteristics	Symbol	Rating	Unit	
Output Zener-breakdown Voltage	V <sub>Z</sub>	38	V	
Operating Supply Voltage	V <sub>CC</sub>	28	V	
Output Current	I <sub>O(AVE)</sub>	300	mA	
	I <sub>O(PEAK)</sub>	400		
Power Dissipation	P <sub>D</sub>	SIP5	550	mW
		SOT89-5	800	
Operating Temperature	T <sub>opr</sub>	-20 ~ 100	°C	
Storage Temperature	T <sub>stg</sub>	-55 ~ 150	°C	
Maximum Junction Temp.	T <sub>J</sub>	150	°C	

**■ Electrical Characteristics** ( $T_a = 25^\circ\text{C}$ , V<sub>CC</sub> = 12V, unless otherwise notice)

Characteristics	Symbol	Conditions	Min.	Typ.	Max.	Unit
Supply Voltage	V <sub>CC</sub>	Operating	10		20	V
Supply current	I <sub>CC</sub>	Operating	-	2.0	4.0	mA
Locked Protection On	T <sub>lrp-on</sub>			0.4		Sec
Locked Protection Off	T <sub>lrp-off</sub>			2.4		Sec
Output saturation voltage	V <sub>OUT(sat)</sub>	I <sub>O</sub> =150mA	-	375	-	mV
		I <sub>O</sub> =250mA	-	625	-	
Output On resistance	R <sub>ds(on)</sub>			2.6		ohm
RD output V <sub>ds</sub>	V <sub>ol</sub>	I <sub>O</sub> =10mA		0.5		V

**■ Magnetic Characteristics** ( $T_a = 25^\circ\text{C}$ , V<sub>CC</sub> = 12V, unless otherwise specified)

(1mT=10 Gauss)

Characteristics	Symbol	Min.	Typ.	Max.	Unit
Operate Point	B <sub>op</sub>	--	30	60	Gauss
Release Point	B <sub>rp</sub>	-60	-30	--	Gauss
Hysteresis	B <sub>hy</sub>	--	60	--	Gauss

### ■ Operating Characteristics

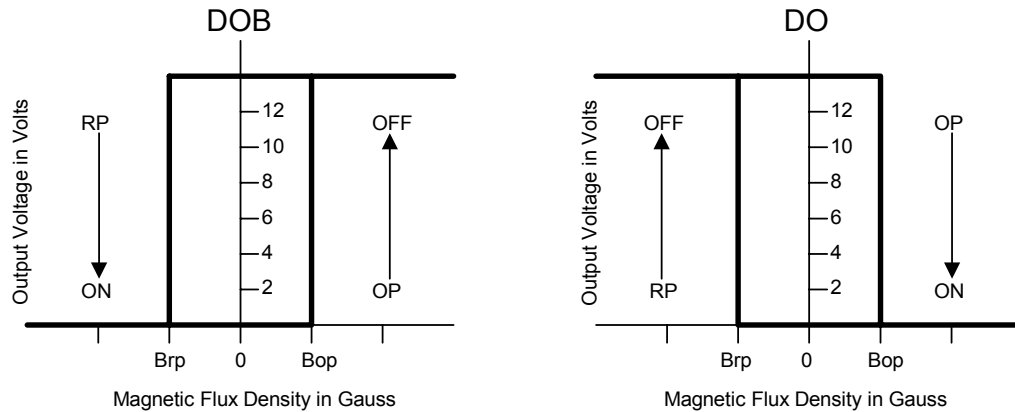

### ■ Performance Characteristics (SIP5)

Ta (°C)	25	50	60	70	80	85	90	95	100	105	110	115	120
Pd (mW)	550	440	396	352	308	286	264	242	220	198	176	154	132

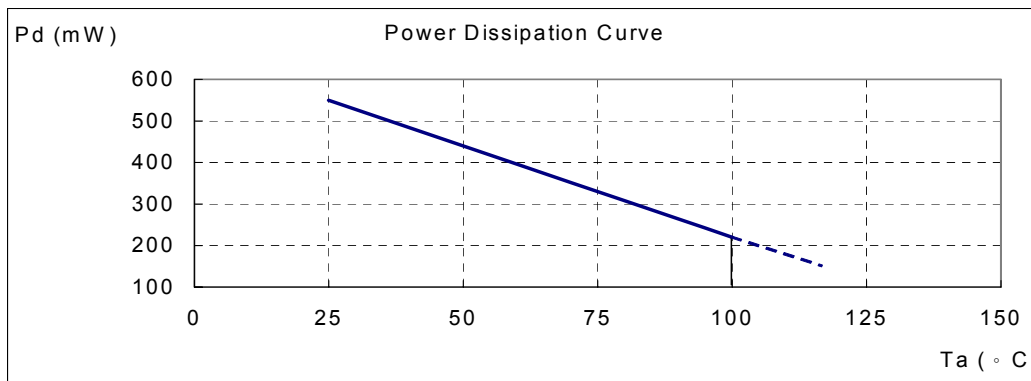

### ■ Marking Information

#### (1)SIP-5L

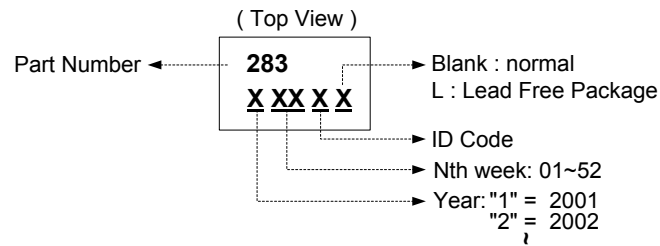

#### (2)SOT89-5L

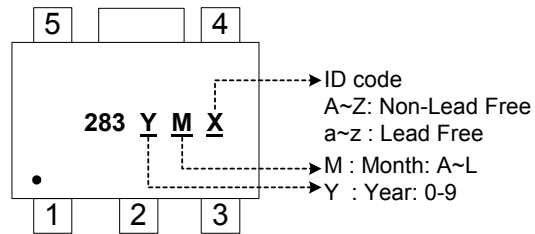

### ■ Package Information

(1) Package type: SIP-5L (unit: mm / [inch])

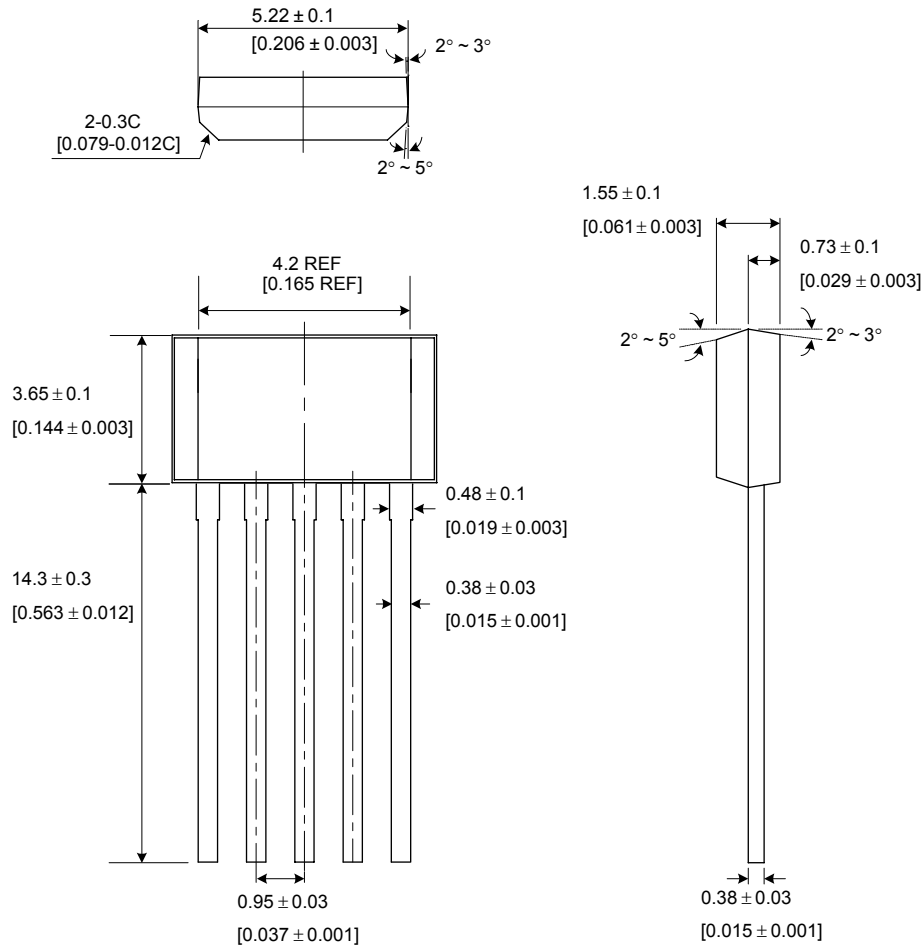

### ■ Location of Sensing Point

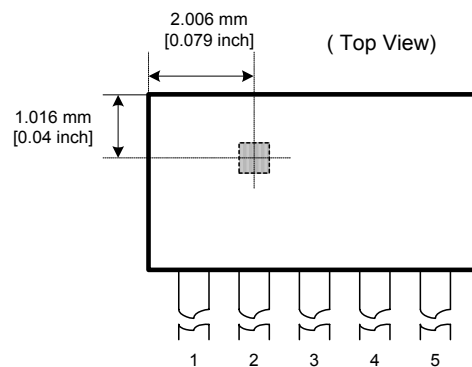

## Hall-Effect Smart Fan Motor Controller

### (2) Package type: SOT89-5L

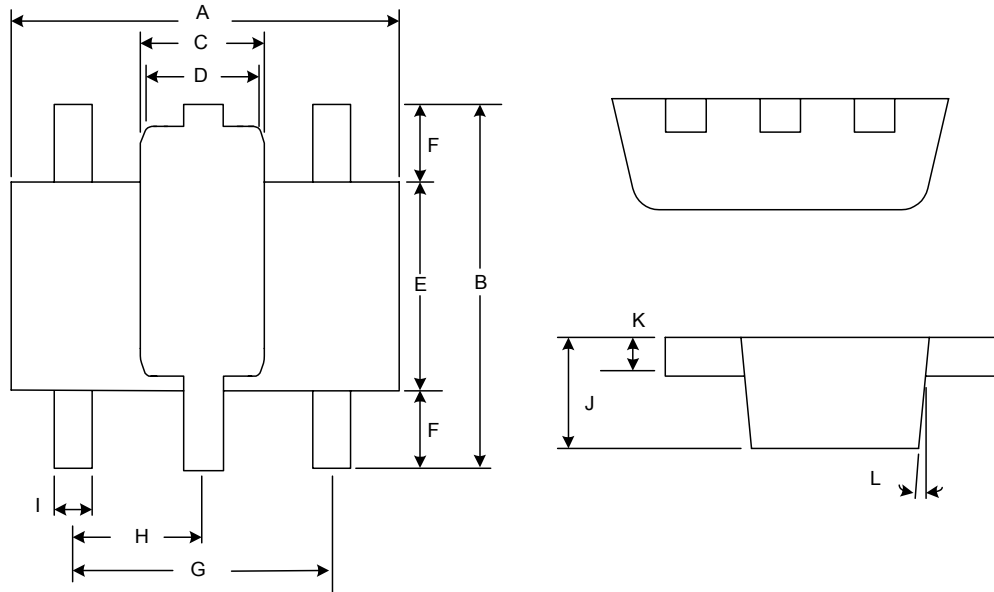

### Package Sensor Location

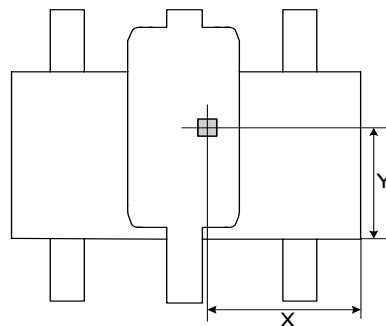

Symbol	Dimensions In Millimeters			Dimensions In Inches		
	Min.	Nom.	Max.	Min.	Nom.	Max.
A	4.40	4.50	4.60	0.173	0.177	0.181
B	4.05	4.15	4.25	0.159	0.163	0.167
C	1.50	1.60	1.70	0.059	0.063	0.067
D	1.30	1.40	1.50	0.051	0.055	0.059
E	2.40	2.50	2.60	0.094	0.098	0.102
F	0.80	-	-	0.031	-	-
G	3.00 Ref.			0.118 Ref.		
H	1.50 Ref.			0.059 Ref.		
I	0.40	0.46	0.52	0.016	0.018	0.020
J	1.40	1.50	1.60	0.055	0.059	0.063
K	0.35	0.39	0.43	0.014	0.015	0.017
L	5° Typ.			5° Typ.		
X	-	1.90	-	-	0.075	-
Y	-	1.65	-	-	0.065	-