

TOSHIBA Bi-CMOS INTEGRATED CIRCUIT SILICON MONOLITHIC

TB62003P, TB62003F, TB62003FW, TB62004P, TB62004F, TB62004FW, TB62006P
 TB62006F, TB62006FW, TB62007P, TB62007F, TB62007FW, TB62008P, TB62008F
 TB62008FW, TB62009P, TB62009F, TB62009FW

8CH DMOS TRANSISTOR ARRAY WITH GATE

TB62003P, TB62003F, TB62003FW
 INVERTER & DMOS DRIVER

TB62004P, TB62004F, TB62004FW
 THROUGH & DMOS DRIVER

TB62006P, TB62006F, TB62006FW
 NAND & DMOS DRIVER

TB62007P, TB62007F, TB62007FW
 AND & DMOS DRIVER

TB62008P, TB62008F, TB62008FW
 NOR & DMOS DRIVER

TB62009P, TB62009F, TB62009FW
 OR & DMOS DRIVER

The TB62003 Series are high-voltage, high-current arrays comprised of eight N-ch DMOS pairs.

FEATURES

- Package : Type-P DIP-20pin
 Type-F SOP-20pin (200mil)
 Type-FW SOL-20pin (300mil)
- Output rating : 35V (Min.) / 200mA (Max.)
- Low power

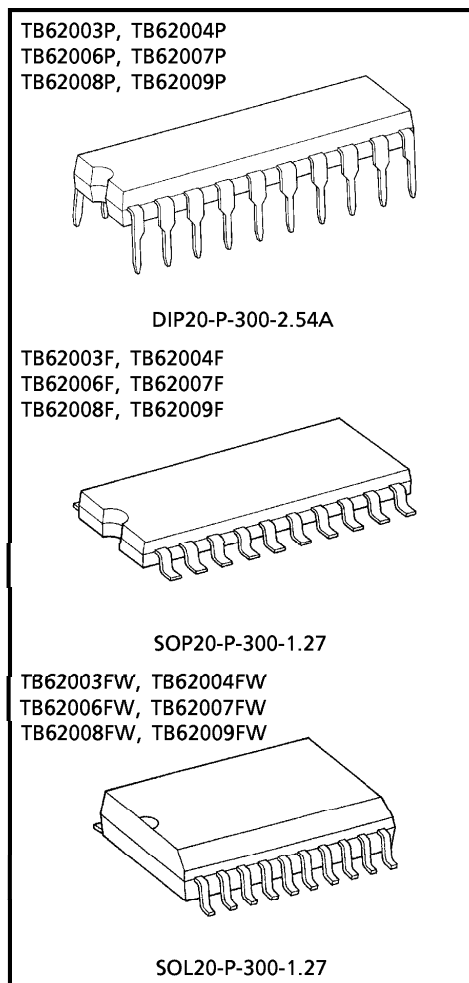

Weight
 DIP20-P-300-2.54A : 2.25g (Typ.)
 SOP20-P-300-1.27 : 0.25g (Typ.)
 SOL20-P-300-1.27 : 0.48g (Typ.)

961001EBA2

- TOSHIBA is continually working to improve the quality and the reliability of its products. Nevertheless, semiconductor devices in general can malfunction or fail due to their inherent electrical sensitivity and vulnerability to physical stress. It is the responsibility of the buyer, when utilizing TOSHIBA products, to observe standards of safety, and to avoid situations in which a malfunction or failure of a TOSHIBA product could cause loss of human life, bodily injury or damage to property. In developing your designs, please ensure that TOSHIBA products are used within specified operating ranges as set forth in the most recent products specifications. Also, please keep in mind the precautions and conditions set forth in the TOSHIBA Semiconductor Reliability Handbook.
- The products described in this document are subject to foreign exchange and foreign trade control laws.
- The information contained herein is presented only as a guide for the applications of our products. No responsibility is assumed by TOSHIBA CORPORATION for any infringements of intellectual property or other rights of the third parties which may result from its use. No license is granted by implication or otherwise under any intellectual property or other rights of TOSHIBA CORPORATION or others.
- The information contained herein is subject to change without notice.

PIN CONNECTION (TOP VIEW)

TB62003P / F / FW

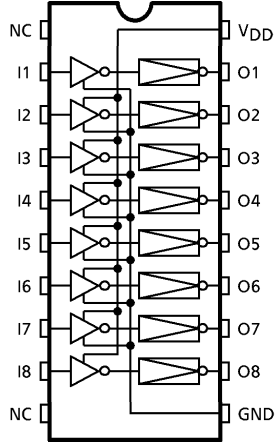

TB62004P / F / FW

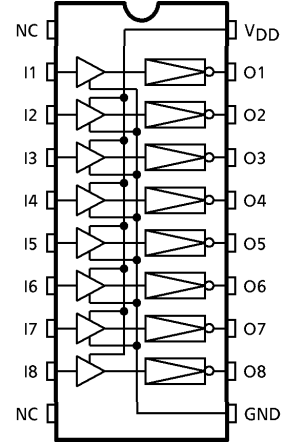

TB62006P / F / FW

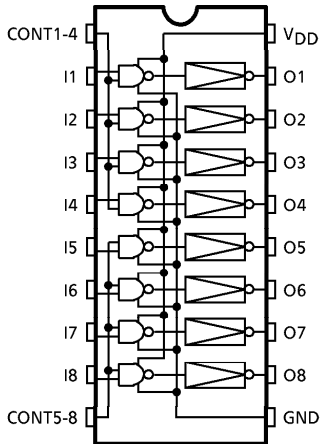

TB62007P / F / FW

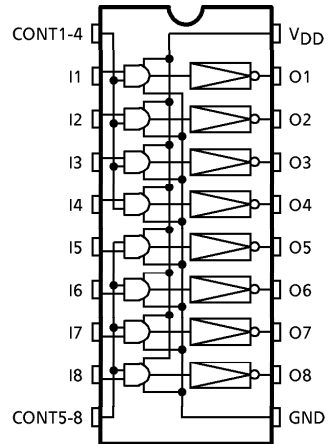

TB62008P / F / FW

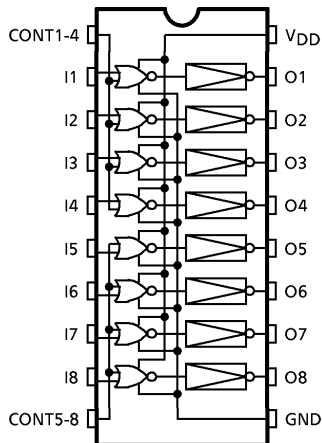

TB62009P / F / FW

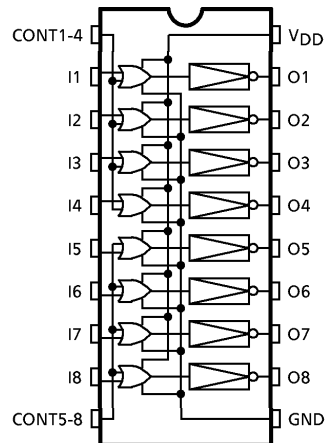

TRUTH TABLE
TB62006P/F/FW

INPUT				OUTPUT	
I1~4	I5~8	CONT1~4	CONT5~8	O3~4	O5~8
H	X	H	X	OFF	NOT FIX
H	X	L	X	ON	NOT FIX
L	X	H	X	ON	NOT FIX
L	X	L	X	ON	NOT FIX
X	H	X	H	NOT FIX	OFF
X	H	X	L	NOT FIX	ON
X	L	X	H	NOT FIX	ON
X	L	X	L	NOT FIX	ON

X : Don't Care

TB62007P/F/FW

INPUT				OUTPUT	
I1~4	I5~8	CONT1~4	CONT5~8	O3~4	O5~8
H	X	H	X	ON	NOT FIX
H	X	L	X	OFF	NOT FIX
L	X	H	X	OFF	NOT FIX
L	X	L	X	OFF	NOT FIX
X	H	X	H	NOT FIX	ON
X	H	X	L	NOT FIX	OFF
X	L	X	H	NOT FIX	OFF
X	L	X	L	NOT FIX	OFF

X : Don't Care

TB62008P/F/FW

INPUT				OUTPUT	
I1~4	I5~8	CONT1~4	CONT5~8	O3~4	O5~8
H	X	H	X	OFF	NOT FIX
H	X	L	X	OFF	NOT FIX
L	X	H	X	OFF	NOT FIX
L	X	L	X	ON	NOT FIX
X	H	X	H	NOT FIX	OFF
X	H	X	L	NOT FIX	OFF
X	L	X	H	NOT FIX	OFF
X	L	X	L	NOT FIX	ON

X : Don't Care

TB62009P/F/FW

INPUT				OUTPUT	
I1~4	I5~8	CONT1~4	CONT5~8	O3~4	O5~8
H	X	H	X	ON	NOT FIX
H	X	L	X	ON	NOT FIX
L	X	H	X	ON	NOT FIX
L	X	L	X	OFF	NOT FIX
X	H	X	H	NOT FIX	ON
X	H	X	L	NOT FIX	ON
X	L	X	H	NOT FIX	ON
X	L	X	L	NOT FIX	OFF

X : Don't Care

MAXIMUM RATINGS (Ta = 25°C)

CHARACTERISTIC	SYMBOL	RATING	UNIT
Supply Voltage	V _{DD}	7	V
DC Output Voltage	V _{DS}	-0.5~35	V
DC Output Current	I _{DS}	200	mA / ch
DC Input Voltage	V _{IN}	-0.4 + V _{DD} + 0.4	V
DC Input Current	I _{IN}	± 5	mA
Input Diode Current	I _{ID}	± 5	mA
Output Diode Current	I _{OK}	5	mA
Power Dissipation	P	1.47	W
	F	0.96 (Note 1)	
	FW	1.00 (Note 2)	
Operating Temperature	T _{opr}	-40~85	°C
Storage Temperature	T _{stg}	-55~150	°C

(Note 1) On Glass Epoxy PCB (50×50×1.6mm Cu 40%)

(Note 2) Delated above 25°C in the proportion of 7.7mW/°C (F Type), 8.0mW/°C (FW Type).

RECOMMENDED OPERATING CONDITION (Ta = -40~85°C)

CHARACTERISTIC	SYMBOL	CONDITION		MIN.	TYP.	MAX.	UNIT
Supply Voltage Range	V _{DD}	—		4.5	—	5.5	V
DC Output Voltage	V _{DS}	—		—	—	30	V
DC Output Current	P	Duty 80%	8ch On V _{DD} = 5.0V	—	—	170	mA / ch
				—	—	90	
	FW	Duty 100%		—	—	140	
				—	—	150	
	P	Duty 80%		—	—	80	
				—	—	120	
FW	Duty 100%	—	—	—	—	—	
		—	—	—	—	—	
DC Input Voltage	V _{IN}	—		GND	—	V _{DD}	V

ELECTRICAL CHARACTERISTICS (Ta = 25°C, VDD = 5.0V)

CHARACTERISTIC	SYMBOL	TEST CIR-CUIT	TEST CONDITION	MIN.	TYP.	MAX.	UNIT
Output Leakage Current	I _{OZ}	—	V _{DS} = 35V	—	—	50	μA
Low-Level Output Voltage	V _{DS}	—	I _{DS} = 150mA	—	0.70	0.8	V
		—	I _{DS} = 200mA	—	0.94	1.2	
Output Resistance	R _{ON}	—	I _{DS} = 200mA	—	4.7	6.0	Ω
DC Input Current	I _{IN}	—	V _{IN} = GND, V _{IN} = V _{DD}	—	—	± 1.0	μA
High-Level Input Voltage	V _{IN} (H)	—	—	3.5	—	V _{DD} + 0.4	V
	V _{IN} (L)	—	—	-0.4	—	1.5	
Operating Supply Current	I _{DDopr}	—	8ch On, Output open f _{IN} = 1MHz	—	2	—	μA
Output Diode Forward Voltage	V _{FK}	—	I _{OK} = 5mA	—	0.6	—	V
Turn-On Delay	t _{ON}	—	I _{OUT} = 170mA	—	300	—	ns
Turn-Off Delay	t _{OFF}	—	—	—	300	—	
Supply Current	I _{DD}	—	—	—	—	10	μA
Input Capacitance	C _{IN}	—	—	—	15	—	pF

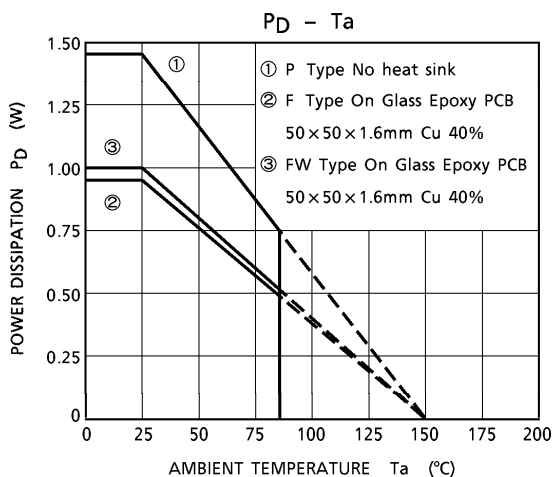

PRECAUTIONS for USING

Utmost care is necessary in the design of the output line, V_{CC} (V_{DD}) and GND line since IC may be destroyed due to short-circuit between outputs, air contamination fault, or fault by improper grounding.

OUTLINE DRAWING
DIP20-P-300-2.54A

Unit : mm

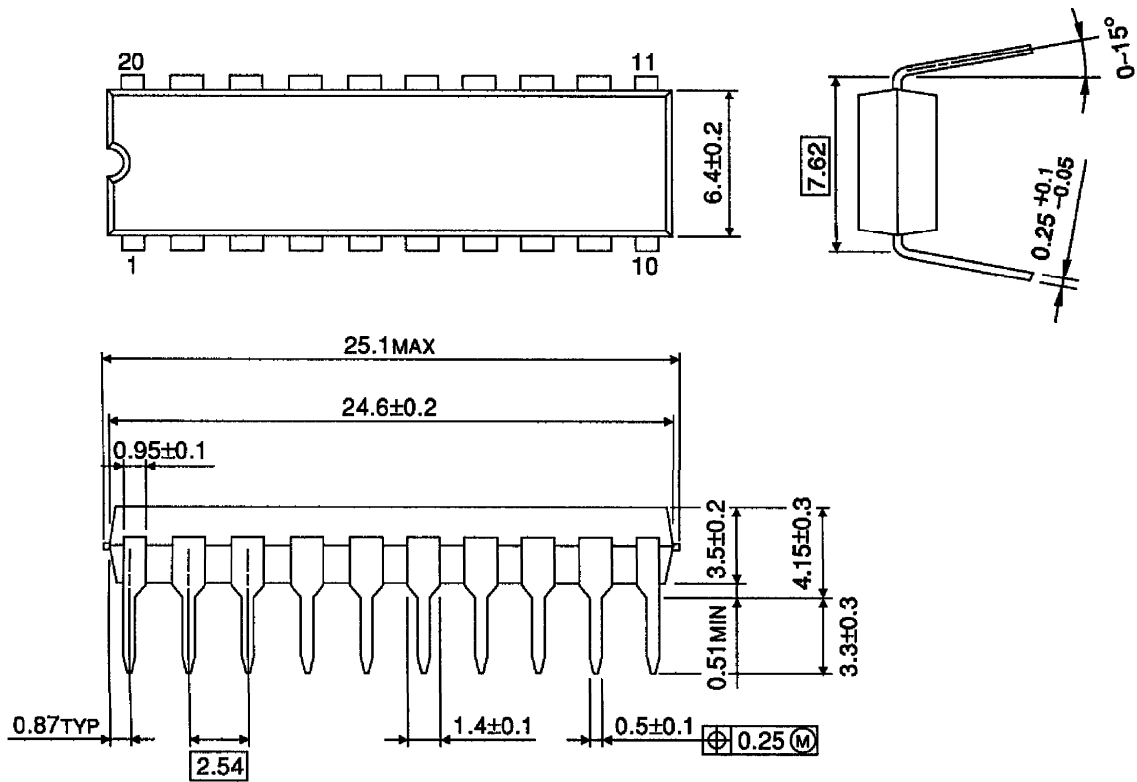

Weight : 2.25g (Typ.)

OUTLINE DRAWING
SOP20-P-300-1.27

Unit : mm

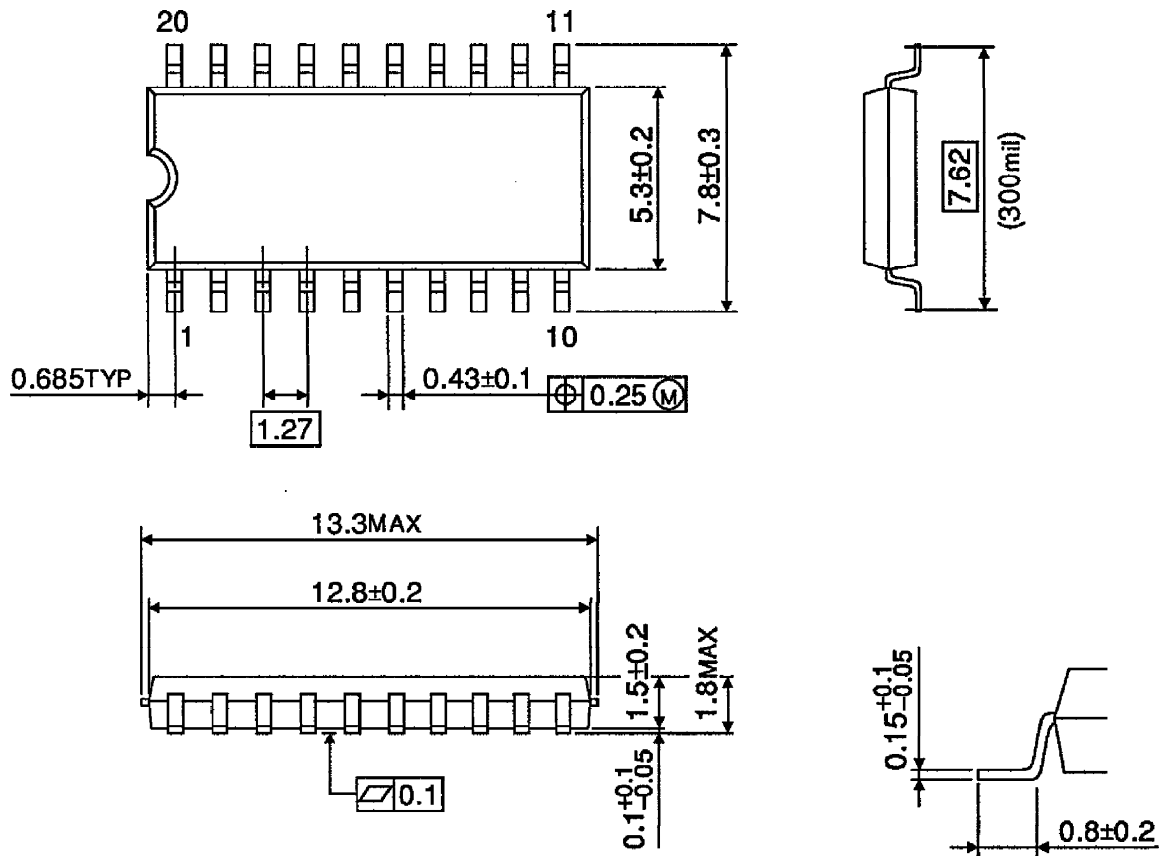

Weight : 0.25g (Typ.)

OUTLINE DRAWING
SOL20-P-300-1.27

Unit : mm

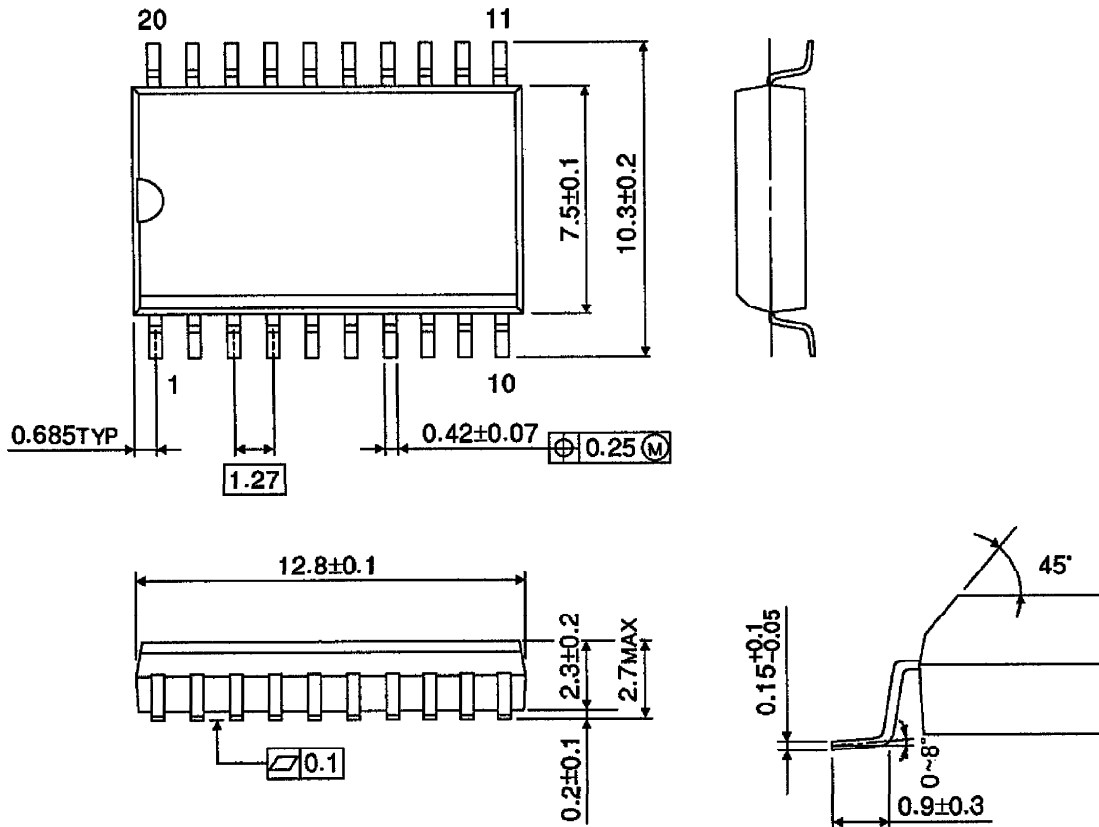

Weight : 0.48g (Typ.)