

1. Functions

1. Real time (month, date, hours, minutes, seconds)
2. 2 switches of SET switch, SELECT switch
3. LCD light-up system by duplex drive
4. Selectable real time display mode
 - Hours, minutes display mode
 - Month, date display mode
 - Seconds display mode
5. Alternating display mode available
6. 12/24-hour operation mode selectable by chip bonding
7. Automatic calendar (Programmed to count date in February up to the 28th.)
8. Reference frequency $f_{OSC}=32.768kHz$
9. Battery voltage 1.5V, with built-in doubler circuit

2. Display System

1. 3-1/2 digits LCD
2. 32Hz duplex drive
3. Display font



4. Panel layout

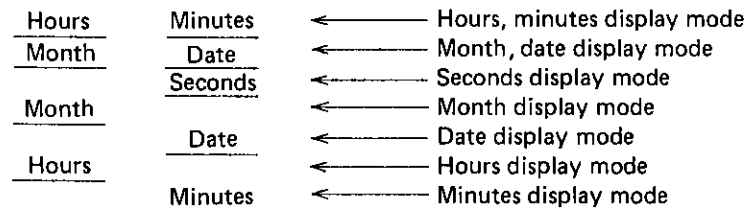
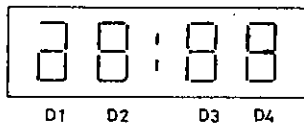

5. Output pins for display 14 pads
 - Segment output 1st digit: 3 segments, 3rd digit: 6 segments, other 2 digits: 7 segments
 - Colon 1 segment
 - Common 2 pins of COMMON1, COMMON2
6. Total number of pads - - - 32 pads

3. Operation Flow

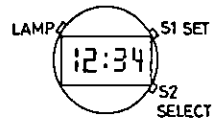
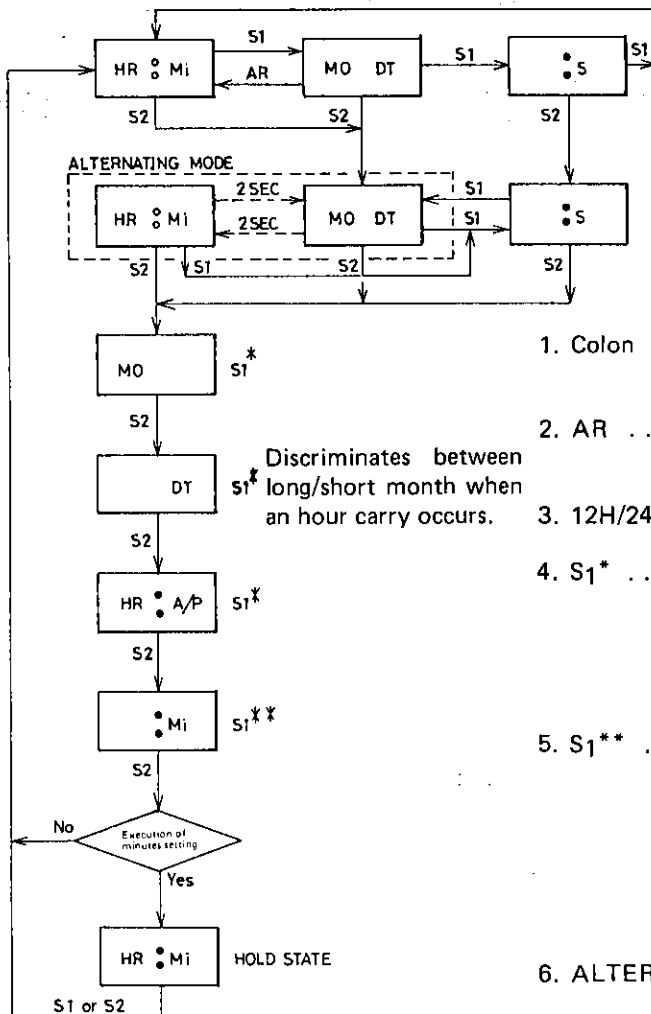

- 1. Colon ◯ Flashing at 1Hz 50% duty
● Lighted
- 2. AR Returns automatically 1 to 2 seconds after releasing the switch.
- 3. 12H/24H select Bonding option
- 4. S1* Execution of setting
One advance per push
Holding pushed for 1 second or more causes fast advance at a 4 Hz rate.
- 5. S1** Execution of setting
One advance per push
Holding pushed for 1 second or more causes fast advance at a 4Hz rate.
Clears seconds and stops time-keeping.
- 6. ALTERNATING MODE
Alternates the hours, minutes display mode/month, date display mode at 2-second intervals.
- 7. A/P Indicates AM/PM in 12-hour operation mode.
(Example)
AM: 6: A (6a.m.)
PM: 7: P (7p.m.)
- 8. HOLD STATE
Holds the counter and stops time-keeping
Pushing switch S1 or S2 starts timekeeping.
- 9. Pushing switches S1 and S2 simultaneously causes the initial mode to occur and the hours, minutes display mode is entered as follows:
(12H display mode) AM 1:00:00 Jan. 1
(24H display mode) 1:00:00 Jan. 1

4. Block Diagram

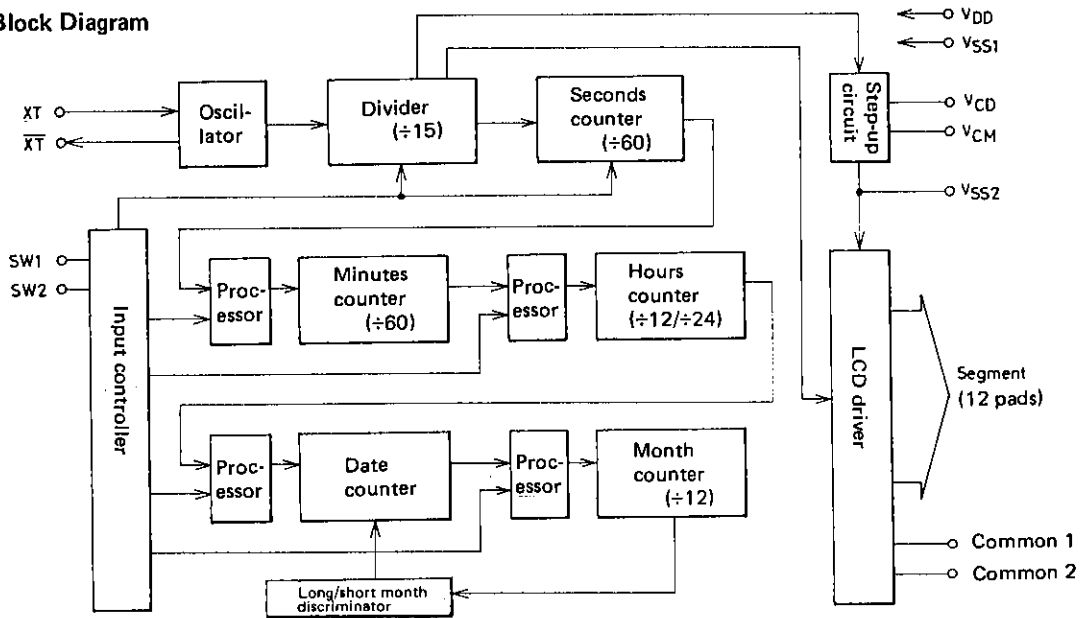

5. Operating Specification

5-1. Hours, minutes display mode

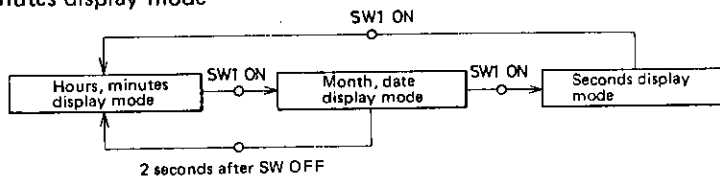

- In the hours, minutes display mode the colon flashes at a 1Hz rate and 50% duty.
- The 10's digit of hours is zero-blanked.
- In the 12-hour operation mode the hours digits change as 1 → 2 → → 12 → 1.
- In the 24-hour operation mode the hours digits change as 0 → 1 → → 23 → 0.

5-2. Month, date display mode

- In the month, date display mode the colon is unlighted.
- The 10's digit of both month and date is zero-blanked.
- Discrimination between long month and short month is exercised when an hour carry occurs and February date is counted up to 28th.

5-3. Seconds display mode

- In the seconds display mode the colon flashes.
- Seconds are displayed on the right 2 digits, with the left 2 digits blanked.

5-4. Alternating display mode

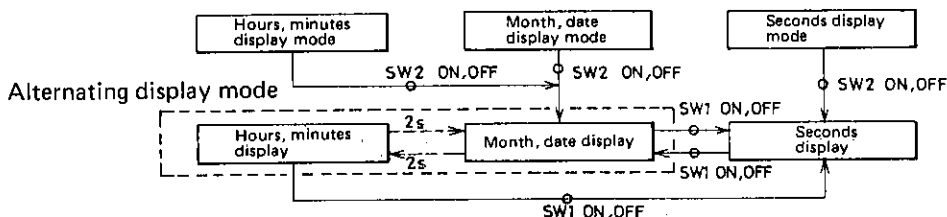

- By pushing switch S2 in the hours, minutes display mode or month, date display mode, the alternating display mode is entered. By pushing switch S2 and then switch S1 in the seconds display mode, the alternating display mode is also entered.
- When the alternating display mode is entered, the month, date display appears. The hour, minutes display appears 2 seconds later, and then the month, date display returns 2 seconds later. This is repeated.

5-5. Time setting mode

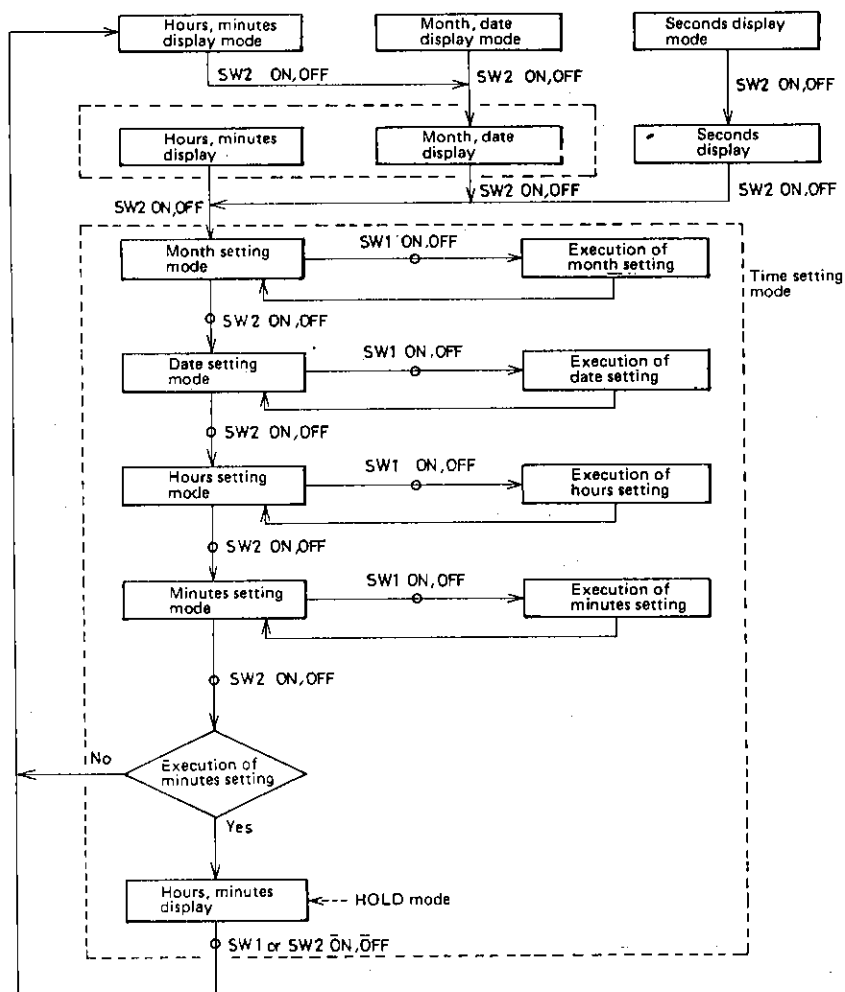

- Only the digit to be set is lighted and displayed. In the month setting mode the month digits only are displayed.
- In the month or hours setting mode the month or hours are displayed on the left 2 digits. In the date or minutes setting mode the date or minutes are displayed on the right 2 digits.
- In the hours or minutes setting mode the colon is lighted. In the month or date setting mode the colon is unlighted.
- Each time SW₁ is pushed/released in each setting mode, the display contents are incremented +1. Holding SW₁ pushed for 1 to 2 seconds or more causes the display contents to advance at a 4Hz rate.
- Execution of setting in each setting mode
 - (a) Execution of month setting The month counter counts up to 12.
 - (b) Execution of date setting The date counter counts up to 31 regardless of long/short month. No carry to the month digits occurs. Discrimination between long month and short month is exercised only when a carry from the hours digits occurs.
 - (c) Execution of hours setting In the 12-hour operation mode "A" is displayed on the rightmost digit when in the morning; "P" is displayed when in the afternoon. The display contents change as 11a.m. → 12p.m. → 1p.m. or 11p.m. → 12a.m. → 1a.m. In the 24-hour operation mode the display contents change as 23 → 0. No carry to the date digits occurs.

- (d) Execution of minutes setting . . . When minutes setting is executed, seconds are cleared and the time is held as set. This is proved by the fact that when SW₂ is pushed/released after execution of minutes setting the hours, minutes display appears but the colon remains lighted without flashing. By pushing/releasing SW₁ or SW₂ under this state, the time hold is released, timekeeping starts, and the normal hours, minutes display mode returns with the colon flashing. If in the minutes setting mode SW₂ is pushed/released without execution of minutes setting, the setting mode returns to the normal hours, minutes display mode.

6. Sample Display of Each Mode

- 6-1. Hours, minutes display mode
(For the alternating display mode also, this applies.)

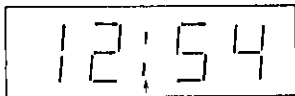

Colon: Flashing at a 1Hz rate (50% duty)
Hour, minutes display (12:54)

- 6-2. Month, date display mode
(For the alternating display mode also, this applies.)

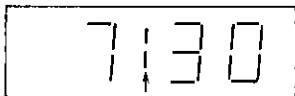

Colon: Unlighted
Month, date display (July 30)

- 6-3. Seconds display mode

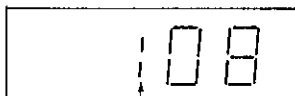

Colon: Unlighted
Seconds display (08)

- 6-4. Month setting mode

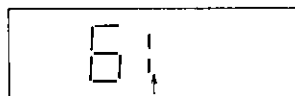

Colon: Unlighted
Month only (June)

- 6-5. Date setting mode

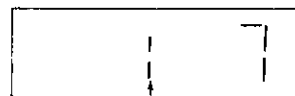

Colon: Unlighted
Date only (7)

- 6-6. Hours setting mode

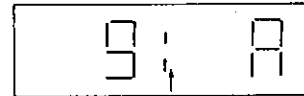

Colon: Lighted Indicating AM

12-hour operation mode Hours only
(9a.m.)

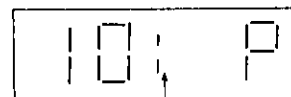

Colon: Lighted Indicating PM

12-hour operation mode Hours only
(10p.m.)

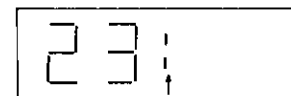

Colon: Lighted

24-hour operation mode Hours only
(23)

- 6-7. Minutes setting mode

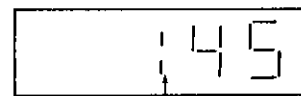

Colon: Lighted

Minutes only (45)

- 6-8. Hold mode

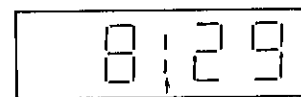

Colon: Lighted
Hours, minutes display (8:29)

7. Others

- 7-1. Zero blanking Unnecessary 0's are unlighted.
 Unlighted content The 10's digit of month, date, hours is zero-blanked.
 Lighted content 0 in the 10's digit of minutes, seconds is lighted.

7-2. Switch input voltage
 The INPUT pin contains a floating preventing resistor. V_{DD} is applied to this pin to start operation.

7-3. 24/12-hour operation mode select
 For the 12-hour operation mode, the 24H/12H pin is not bonded. For the 24-hour operation mode, this pin is bonded.

7-4. Setting pulse
 Each time SW₁ is pushed in each setting mode, the display contents are incremented +1. Holding SW₁ pushed causes fast advance at a 4Hz rate to start approximately 1 second later.

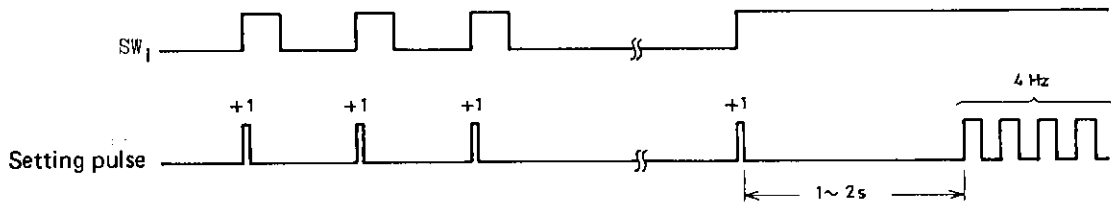

7-5. Switch chattering preventer
 Chattering of 30msec. or less is prevented. (More than 30msec. is considered to be bounding.)

7-6. Step-up circuit
 Two capacitors (0.1 μ F) are connected externally. The step-up frequency is 512Hz.

7-7. Initial clear
 The circuit is built in. The initial mode can be also entered by pushing SW₁ and SW₂ simultaneously.

7-8. LCD output alternating frequency 32Hz

Supply current

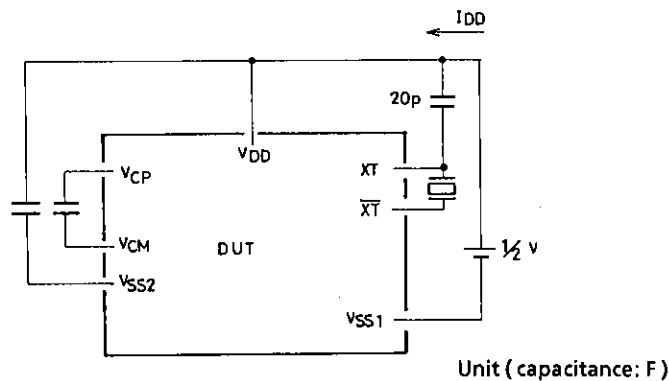

- (Note) ● Pins not entered are all open.
- $C1 \leq 25\text{kohm}$

LC5645N

Oscillation start voltage, oscillation stop voltage, oscillation start time

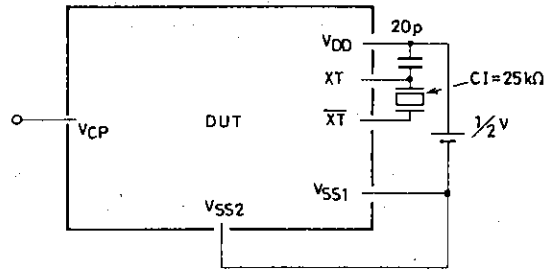

Common-segment time lag

Segment

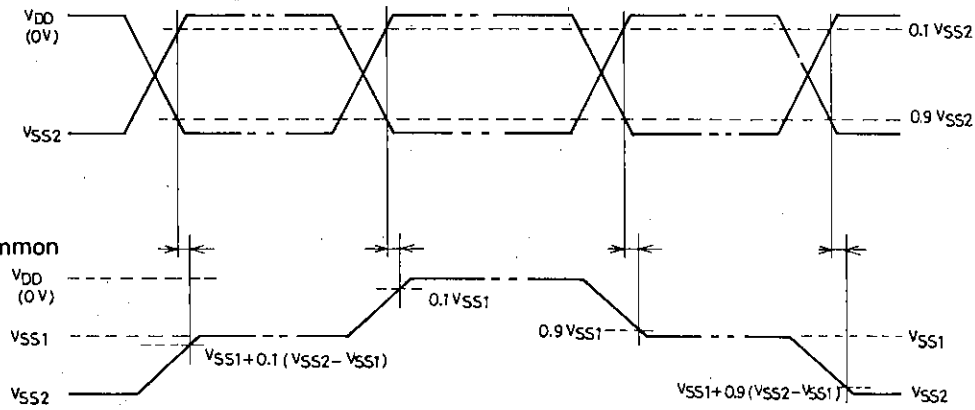

Sample Application Circuit

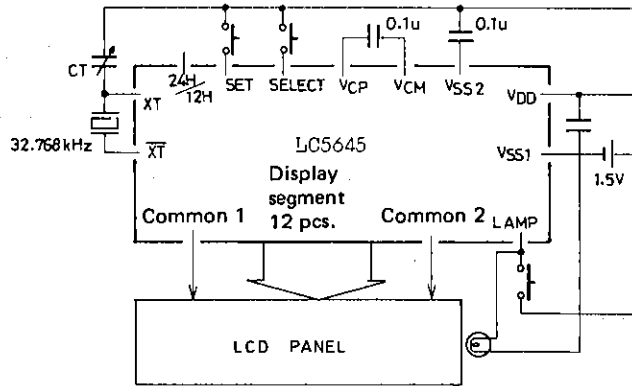

LCD Format (12 hour display format)

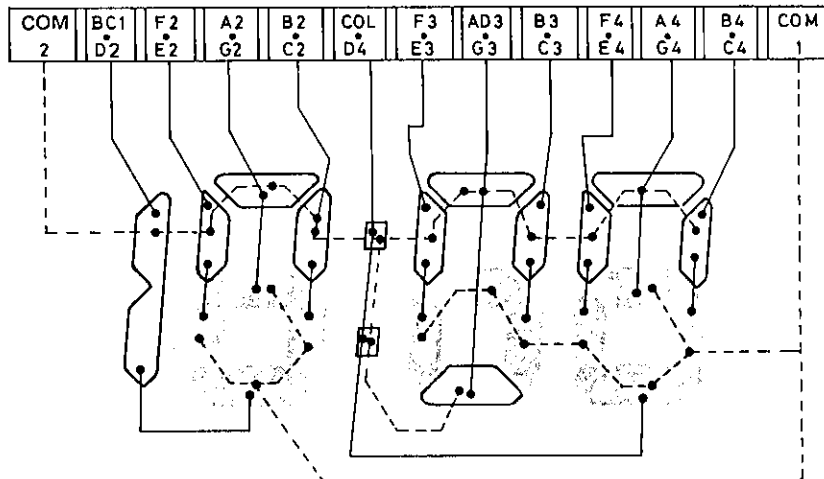

LC5645N

LCD Format (24 hour display format)

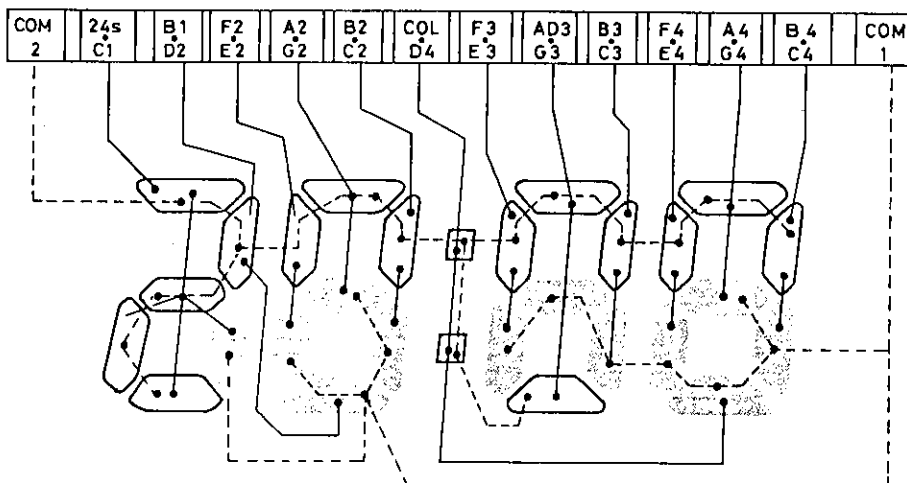

Pad No. and Pin Name

3C5645 (LC5645N)

(unit:mm)

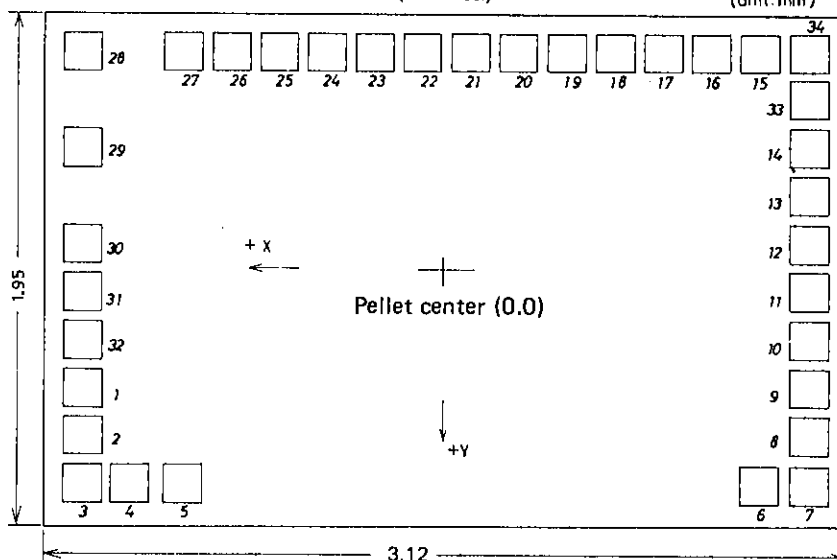

Pad No.	Pin Name	X coordinates (μm)	Y coordinates (μm)	Pad No.	Pin Name	X coordinates (μm)	Y coordinates (μm)
1	V _{dd}	1407	450	18	F4/E4	-585	-822
2	V _{CP} (Cup2)	1407	630	19	B3/C3	-405	-822
3	V _{CM} (Cup1)	1407	822	20	AD3/G3	-225	-822
4	Test 2	1225	822	21	F3/E3	-45	-822
5	32Hz	1045	822	22	C ₀₁ /D4	135	-822
6	Test 1	-1193	822	23	B2/C2	315	-822
7	V _{SS1}	-1407	822	24	A2/G2	495	-822
8	S2	-1407	630	25	F2/E2	675	-822
9	V _{dd}	-1407	450	26	B1/D2	855	-822
10	24H/12H	-1407	270	27	24S/C1	1035	-822
11	V _{SS2}	-1407	90	28	Common 2	1407	-822
12	Test 3	-1407	-90	29	Lamp	1407	-467
13	Test 4	-1407	-270	30	\overline{XT} (Osc Out)	1407	-90
14	S1	-1407	-450	31	10PF	1407	90
15	Common 1	-1125	-822	32	XT (Osc In)	1407	270
16	B4/C4	-945	-822	33	Monitor	1407	-630
17	A4/G4	-765	-822	34	Monitor	1407	-822

* The pad coordinates are such that the pellet center is taken as the origin (0.0).

LC5645N

Absolute Maximum Ratings/ $T_a = 25^\circ\text{C}$, $V_{DD} = 0\text{V}$

				Unit
Maximum supply voltage (1)	V_{SS1}		-4 ~ +0.3	V
Maximum supply voltage (2)	V_{SS2}		-4 ~ +0.3	V
Input voltage	V_{IN}	$S_1, S_2, \text{LAMP}, T_1 \sim T_4, \text{XT}, 24\text{H}/12\text{H}$	$V_{SS1} -0.3 \sim +0.3$	V
Output voltage (1)	V_{OUT1}	$\text{XT}, 32\text{Hz}, V_{CP}$	$V_{SS1} -0.3 \sim +0.3$	V
Output voltage (2)	V_{OUT2}	All segments, Common1, Common2, V_{CM}	$V_{SS2} -0.3 \sim +0.3$	V
Operating temperature	T_{opr}		-20 ~ +75	$^\circ\text{C}$
Storage temperature	T_{stg}		-30 ~ +125	$^\circ\text{C}$

Recommended Operating Conditions/ $T_a = 25^\circ\text{C}$, $V_{DD} = 0\text{V}$

				Unit
Supply voltage (1)	V_{SS1}		-1.65 ~ -1.3	V
Supply voltage (2)	V_{SS2}	$V_{SS1} = -1.3 \sim -1.65$	-3.3 ~ -2.4	V
Input high level	V_{IH}	$V_{SS1} = -1.55\text{V}$ S_1, S_2	-0.2 ~ +0	V
Input low level	V_{IL}	$V_{SS1} = -1.55\text{V}$ S_1, S_2	$V_{SS1} \sim +V_{SS1}+0.2$	V

Electrical Characteristics/ $T_a = 25^\circ\text{C}$, $V_{DD} = 0\text{V}$, $V_{SS} = -1.3 \sim -1.65\text{V}$

			min	typ	max	unit
Input resistance	R_{IN1}	$V_{SS1} = -1.55\text{V}, S_1, S_2, \text{Lamp}$	200		2000	$\text{k}\Omega$
Input resistance	R_{IN2}	$V_{SS1} = -1.55\text{V}$, test input	1		100	$\text{k}\Omega$
Input resistance	R_{IN3}	$V_{SS1} = -1.55\text{V}$, "L" level hold T_r , 24H/12H	10		100	$\text{k}\Omega$
Input resistance	R_{in4}	$V_{SS1} = -1.55\text{V}$, "L" level pull-in T_r , 24H/12H	200		2000	$\text{k}\Omega$
Output "H" level voltage	V_{OH1}	$V_{SS1} = -1.55\text{V}$, $I_{OH} = -0.4\mu\text{A}$, segment, colon	-0.2			V
Output "L" level voltage	V_{OL1}	$V_{SS1} = -1.55\text{V}$, $I_{OL} = 0.4\mu\text{A}$, segment, colon			$V_{SS2} +0.2$	V
Output "H" level voltage	V_{OH2}	$V_{SS1} = -1.55\text{V}$, $I_{OH} = -4\mu\text{A}$, Common1, Common2	-0.2			V
Output "M" level voltage	V_{OM}	$V_{SS1} = -1.55\text{V}$, $I_{OH} = -4\mu\text{A}$, $I_{OL} = 4\mu\text{A}$, Common1, Common2	$V_{SS1} -0.2$		$V_{SS1} +0.2$	V
Output "L" level voltage	V_{OL2}	$V_{SS1} = -1.55\text{V}$, $I_{OL} = 4\mu\text{A}$, Common1, Common2			$V_{SS2} +0.2$	V
Input leakage current	I_{off}	$V_{SS1} = -2\text{V}$, $V_{SS2} = -4\text{V}$, 24/12H off mode			0.1	μA
Step-up voltage	V_{SS2}	$C_1 = C_2 = 0.1\mu\text{F}$, $3\text{M}\Omega$ across $V_{DD} - V_{SS2}$ $f_{opg} = 32.768\text{kHz}$	-3.3		-2.5	V
Supply current	I_{DD}	$V_{SS1} = -1.55\text{V}$, $C_1 = C_2 = 0.1\mu\text{F}$ $C_o = C_g = 20\text{pF}$, $C_l = 25\text{k}\Omega$		1.0	2.0	μA
Oscillation start voltage	V_{START}	$C_1 = C_2 = 0.1\mu\text{F}$, $C_o = C_g = 20\text{pF}$, $C_l = 25\text{k}\Omega$			-1.45	V
Oscillation hold voltage	V_{HOLD}	$C_1 = C_2 = 0.1\mu\text{F}$, $C_o = C_g = 20\text{pF}$, $C_l = 25\text{k}\Omega$			-1.3	V
Oscillation start time	t_{START}	$V_{SS1} = -1.55\text{V}$, $C_1 = C_2 = 0.1\mu\text{F}$, $C_o = C_g = 20\text{pF}$, $C_l = 25\text{k}\Omega$			10	s
Oscillation capacitance (10pF pin)	C_o		8		12	pF
Common-segment time lag	t_D	$V_{SS2} = -3.3 \sim -2.5\text{V}$, $C_L = 100\text{p}$	-100	100	100	μs
Built-in Capacitance	C_D			20		pF

- No products described or contained herein are intended for use in surgical implants, life-support systems, aerospace equipment, nuclear power control systems, vehicles, disaster/crime-prevention equipment and the like, the failure of which may directly or indirectly cause injury, death or property loss.
- Anyone purchasing any products described or contained herein for an above-mentioned use shall:
 - ① Accept full responsibility and indemnify and defend SANYO ELECTRIC CO., LTD., its affiliates, subsidiaries and distributors and all their officers and employees, jointly and severally, against any and all claims and litigation and all damages, cost and expenses associated with such use:
 - ② Not impose any responsibility for any fault or negligence which may be cited in any such claim or litigation on SANYO ELECTRIC CO., LTD., its affiliates, subsidiaries and distributors or any of their officers and employees jointly or severally.
- Information (including circuit diagrams and circuit parameters) herein is for example only; it is not guaranteed for volume production. SANYO believes information herein is accurate and reliable, but no guarantees are made or implied regarding its use or any infringements of intellectual property rights or other rights of third parties.