

### RF Power Amplifier Module

### VHF Power Amplifier Module (HAM FM)

#### Features

- Output Power :  $P_o \geq 15W$
- Minimum Gain :  $G_p = 18.7dB$
- Efficiency :  $\eta_T \geq 48\%$
- $50\Omega$  Input/Output Impedance
- Guaranteed Stability

#### Absolute Maximum Ratings (Tc = 25°C)

CHARACTERISTIC	SYMBOL	RATING	UNIT
DC Supply Voltage	$V_{CC}$	16	V
DC Supply Voltage	$V_{CON}$	16	V
RF Input Power	$P_i$	300	mW
Operating Case Temperature Range	$T_c(OP)$	-30 ~ 100	°C
Storage Temperature Range	$T_{sig}$	-40 ~ 110	°C

#### Electrical Characteristics (Tc = 25°C)

CHARACTERISTIC	SYMBOL	TEST CONDITION	MIN.	TYP.	MAX.	UNIT
Frequency Range	$f_{range}$	—	144	—	148	MHz
Output Power	$P_o$	$P_i = 200mW$ $V_{CC} = 12.5V, V_{CON} = 12.5V$ $Z_g = Z_l = 50\Omega$	15	20	—	W
Power Gain	$G_p$		18.7	20	—	dB
Total Efficiency	$\eta_T$		48	53	—	%
Input VSWR	$VSWR_{in}$		—	1.5	2	—
Harmonics	HRM		—	-30	-25	dB
Load Mismatch	—	$V_{CC} = 15V, V_{CON} = 12.5V$ $P_o = 18W$ VSWR Load 20:1 all phase	No Degradation			—
Stability	—	$V_{CC} = 12.5V, P_i = 200mW$ $V_{CON} = 0 \sim 12.5V$ VSWR Load 3:1 all phase	All spurious output than 60dB below desired signal			—

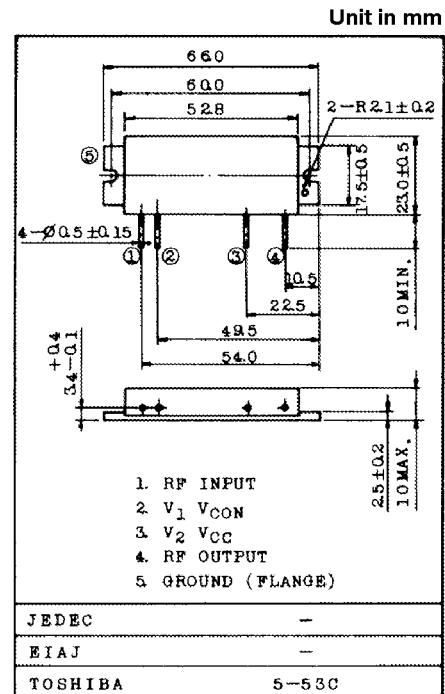

SCHEMATIC

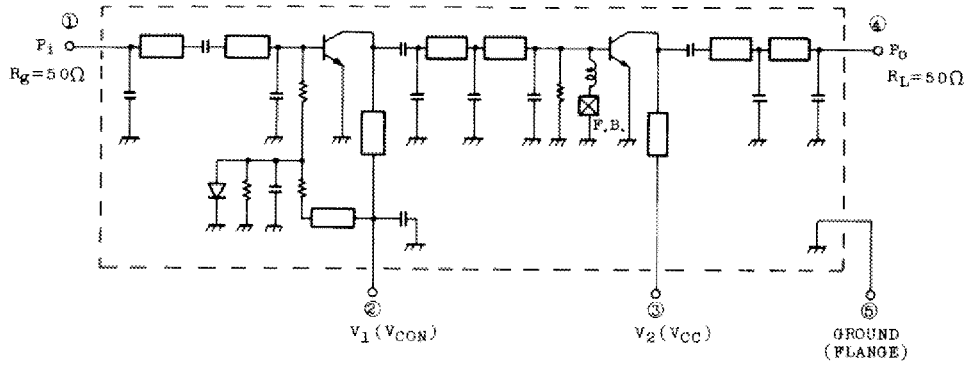

TEST MOUNT

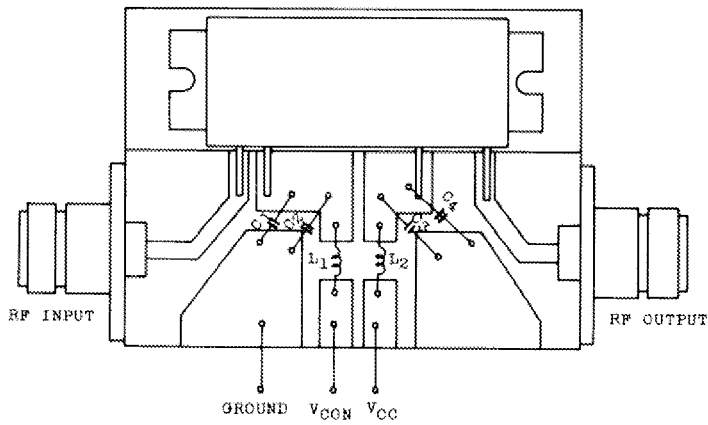

C<sub>1</sub>, C<sub>3</sub> : 15000PF

C<sub>2</sub>, C<sub>4</sub> : 1μF

L<sub>1</sub>, L<sub>2</sub> : 00.8 PLATED WIRE 8T, 5ID

