

# OKI Semiconductor

## MSC23236C/CL-xxBS20/DS20

2,097,152-Word × 36-Bit DRAM MODULE : FAST PAGE MODE TYPE

### DESCRIPTION

The OKI MSC23236C/CL-xxBS20/DS20 is a fully decoded 2,097,152-word × 36-bit CMOS Dynamic Random Access Memory Module composed of sixteen 4-Mb DRAMs (1M × 4) in SOJ packages and four 2-Mb DRAMs in SOJ (1M × 2) packages mounted with twenty decoupling capacitors on a 72-pin glass epoxy single-inline package. This module is generally used for memory expansion in parity applications such as workstations. The low-power version (CL) offers reduced power consumption for mobile computing applications like laptops and palmtops.

### FEATURES

- 2-Meg × 36-bit organization
- 72-Pin Socket Insertable Module  
MSC23236C/CL-xxBS20 : Gold tab  
MSC23236C/CL-xxDS20 : Solder tab
- Single 5 V supply ±10% tolerance
- Access times : 60, 70, 80 ns
- Input : TTL compatible
- Output : TTL compatible, 3-state
- Refresh : 1024 cycles/16 ms (128 ms : L-version)
- $\overline{\text{CAS}}$  before  $\overline{\text{RAS}}$  refresh,  $\overline{\text{CAS}}$  before  $\overline{\text{RAS}}$  hidden refresh,  $\overline{\text{RAS}}$ -only refresh capability
- Multi-bit test mode capability
- Fast Page Mode capability

### PRODUCT FAMILY

Family	Access Time (Max.)			Cycle Time (Min.)	Power Dissipation	
	t <sub>RAC</sub>	t <sub>AA</sub>	t <sub>CAC</sub>		Operating (Max.)	Standby (Max.)
MSC23236C/CL-60BS20/DS20	60 ns	30 ns	15 ns	110 ns	5555 mW	110 mW/ 19.8 mW (L-version)
MSC23236C/CL-70BS20/DS20	70 ns	35 ns	20 ns	130 ns	5005 mW	
MSC23236C/CL-80BS20/DS20	80 ns	40 ns	20 ns	150 ns	4455 mW	

**PIN CONFIGURATION**

**MSC23236C/CL-xxBS20/DS20**

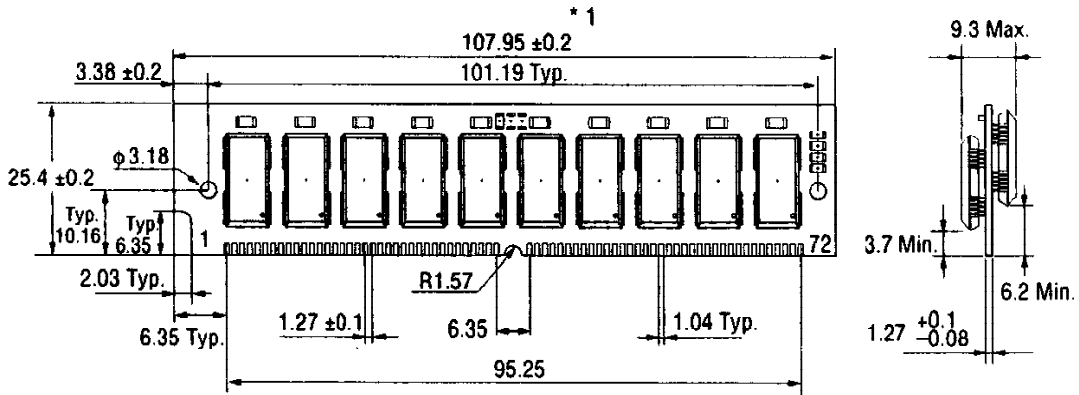

\*1 The common size difference of the board width 12.5 mm of its height is specified as ±0.2. The value above 12.5 mm is specified as ±0.5.

Pin No.	Pin Name	Pin No.	Pin Name	Pin No.	Pin Name	Pin No.	Pin Name	Pin No.	Pin Name
1	V <sub>SS</sub>	16	A4	31	A8	46	NC	61	DQ14
2	DQ0	17	A5	32	A9	47	WE	62	DQ33
3	DQ18	18	A6	33	RAS3	48	NC	63	DQ15
4	DQ1	19	NC	34	RAS2	49	DQ9	64	DQ34
5	DQ19	20	DQ4	35	DQ26	50	DQ27	65	DQ16
6	DQ2	21	DQ22	36	DQ8	51	DQ10	66	NC
7	DQ20	22	DQ5	37	DQ17	52	DQ28	67	PD1
8	DQ3	23	DQ23	38	DQ35	53	DQ11	68	PD2
9	DQ21	24	DQ6	39	V <sub>SS</sub>	54	DQ29	69	PD3
10	V <sub>CC</sub>	25	DQ24	40	CAS0	55	DQ12	70	PD4
11	NC	26	DQ7	41	CAS2	56	DQ30	71	NC
12	A0	27	DQ25	42	CAS3	57	DQ13	72	V <sub>SS</sub>
13	A1	28	A7	43	CAS1	58	DQ31		
14	A2	29	NC	44	RAS0	59	V <sub>CC</sub>		
15	A3	30	V <sub>CC</sub>	45	RAS1	60	DQ32		

**Presence Detect Pins**

Pin No.	Pin Name	MSC23236C/CL-60BS20/DS20	MSC23236C/CL-70BS20/DS20	MSC23236C/CL-80BS20/DS20
67	PD1	NC	NC	NC
68	PD2	NC	NC	NC
69	PD3	NC	V <sub>SS</sub>	NC
70	PD4	NC	NC	V <sub>SS</sub>

**BLOCK DIAGRAM**

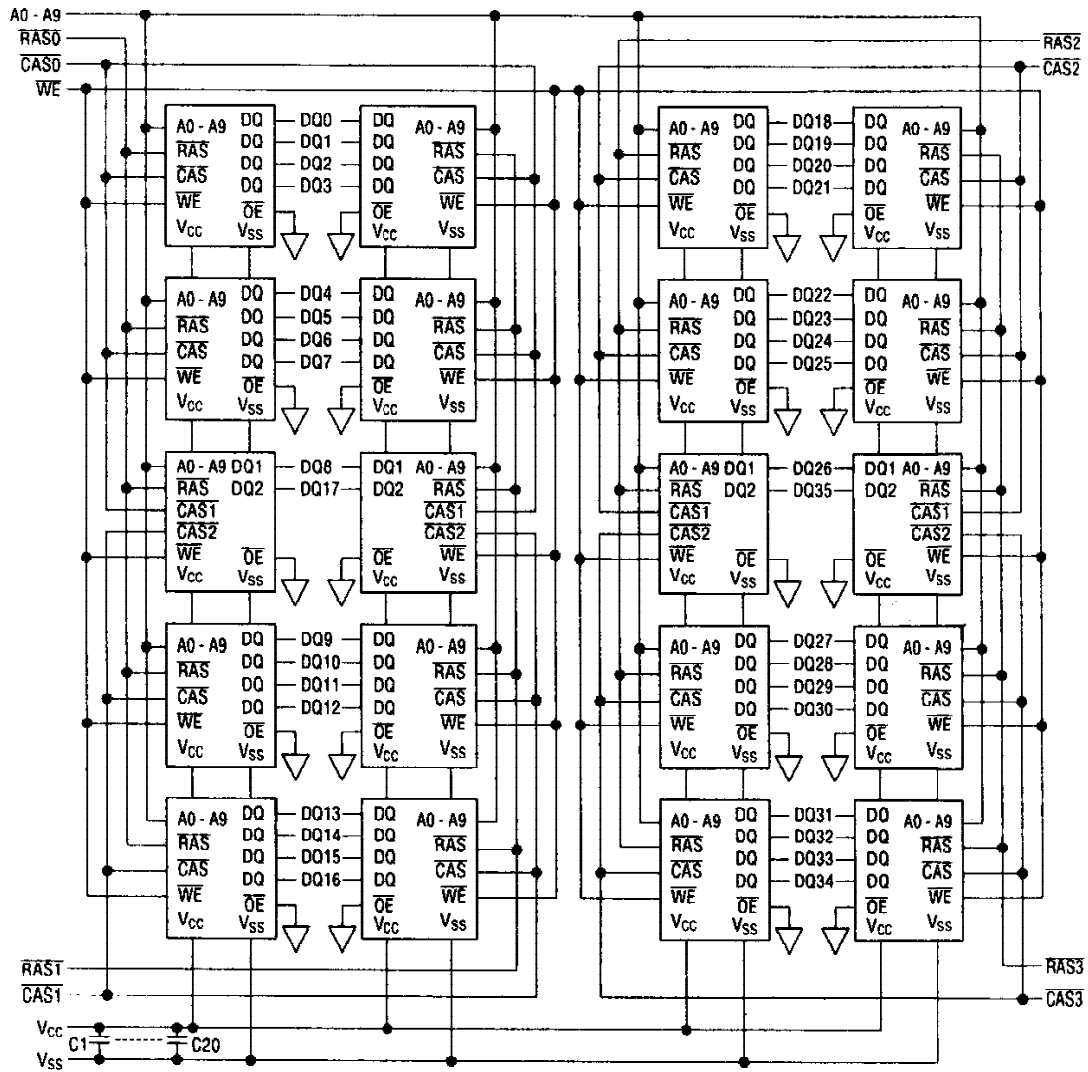

**ELECTRICAL CHARACTERISTICS****Absolute Maximum Ratings**

Parameter	Symbol	Rating	Unit
Voltage on Any Pin Relative to V <sub>SS</sub>	V <sub>IN</sub> , V <sub>OUT</sub>	-1.0 to 7.0	V
Voltage V <sub>CC</sub> Supply Relative to V <sub>SS</sub>	V <sub>CC</sub>	-1.0 to 7.0	V
Short Circuit Output Current	I <sub>OS</sub>	50	mA
Power Dissipation	P <sub>D</sub>	20	W
Operating Temperature	T <sub>opr</sub>	0 to 70	°C
Storage Temperature	T <sub>stg</sub>	-40 to 125	°C

Note: Permanent device damage may occur if ABSOLUTE MAXIMUM RATINGS are exceeded. Functional operation should be restricted to the conditions as detailed in the operational sections of this data sheet. Exposure to absolute maximum rating conditions for extended periods may affect device reliability.

**Recommended Operating Conditions**(T<sub>a</sub> = 0°C to 70°C)

Parameter	Symbol	Min.	Typ.	Max.	Unit
Power Supply Voltage	V <sub>CC</sub>	4.5	5.0	5.5	V
	V <sub>SS</sub>	0	0	0	V
Input High Voltage	V <sub>IH</sub>	2.4	—	6.5	V
Input Low Voltage	V <sub>IL</sub>	-1.0	—	0.8	V

**Capacitance**(T<sub>a</sub> = 25°C, f = 1 MHz)

Parameter	Symbol	Typ.	Max.	Unit
Input Capacitance (A0 - A9)	C <sub>IN1</sub>	—	135	pF
Input Capacitance ( $\overline{WE}$ )	C <sub>IN2</sub>	—	155	pF
Input Capacitance ( $\overline{RAS0}$ - RAS3)	C <sub>IN3</sub>	—	43	pF
Input Capacitance ( $\overline{CAS0}$ - CAS3)	C <sub>IN4</sub>	—	43	pF
I/O Capacitance (DQ0 - DQ35)	C <sub>DQ</sub>	—	20	pF

Note : Capacitance measured with Boonton Meter.

DC Characteristics

( $V_{CC} = 5 V \pm 10\%$ ,  $T_a = 0^\circ C$  to  $70^\circ C$ )

Parameter	Symbol	Condition	MSC23236C/CL -60BS20/DS20		MSC23236C/CL -70BS20/DS20		MSC23236C/CL -80BS20/DS20		Unit	Note
			Min.	Max.	Min.	Max.	Min.	Max.		
			Input Leakage Current	$I_{LI}$	$0 V \leq V_i \leq 6.5 V$ ; All other pins not under test = $0 V$	-200	200	-200		
Output Leakage Current	$I_{LO}$	$D_{OUT}$ disable $0 V \leq V_o \leq 5.5 V$	-20	20	-20	20	-20	20	$\mu A$	
Output High Voltage	$V_{OH}$	$I_{OH} = -5.0 mA$	2.4	$V_{CC}$	2.4	$V_{CC}$	2.4	$V_{CC}$	V	
Output Low Voltage	$V_{OL}$	$I_{OL} = 4.2 mA$	0	0.4	0	0.4	0	0.4	V	
Average Power Supply Current (Operating)	$I_{CC1}$	$\overline{RAS}$ , $\overline{CAS}$ cycling, $t_{RC} = \text{Min.}$	—	1010	—	910	—	810	mA	1, 2
Power Supply Current (Standby)	$I_{CC2}$	$\overline{RAS}$ , $\overline{CAS} = V_{IH}$	—	40	—	40	—	40	mA	1
		$\overline{RAS}$ , $\overline{CAS}$ $\geq V_{CC} - 0.2 V$	—	20	—	20	—	20	mA	1
			—	3.6	—	3.6	—	3.6	mA	1, 5
Average Power Supply Current (RAS-only Refresh)	$I_{CC3}$	$\overline{RAS}$ cycling, $\overline{CAS} = V_{IH}$ , $t_{RC} = \text{Min.}$	—	1010	—	910	—	810	mA	1, 2
Average Power Supply Current (CAS before RAS Refresh)	$I_{CC6}$	$\overline{RAS}$ cycling, $\overline{CAS}$ before $\overline{RAS}$ , $t_{RC} = \text{Min.}$	—	1010	—	910	—	810	mA	1, 2
Average Power Supply Current (Fast Page Mode)	$I_{CC7}$	$\overline{RAS} = V_{IL}$ , $\overline{CAS}$ cycling, $t_{PC} = \text{Min.}$	—	810	—	720	—	630	mA	1, 3
Average Power Supply Current (Battery Backup)	$I_{CC10}$	$t_{RC} = 125 \mu s$ , $\overline{CAS}$ before $\overline{RAS}$ cycling	—	5.6	—	5.6	—	5.6	mA	1, 4 5

- Notes: 1. Specified values are obtained with the output open.  
 2. Address can be changed once or less while  $\overline{RAS} = V_{IL}$ .  
 3. Address can be changed once or less while  $\overline{CAS} = V_{IH}$ .  
 4.  $V_{CC} - 0.2 V \leq V_{IH} \leq 6.5 V$ ,  $-1.0 V \leq V_{IL} \leq 0.2 V$ .  
 5. L-version.

## AC Characteristics (1/2)

(V<sub>CC</sub> = 5 V ±10%, T<sub>a</sub> = 0°C to 70°C) Note 1,2,3,9,10

Parameter	Symbol	MSC23236C/CL -60BS20/DS20		MSC23236C/CL -70BS20/DS20		MSC23236C/CL -80BS20/DS20		Unit	Note
		Min.	Max.	Min.	Max.	Min.	Max.		
		Random Read or Write Cycle Time	t <sub>RC</sub>	110	—	130	—		
Fast Page Mode Cycle Time	t <sub>PC</sub>	40	—	45	—	50	—	ns	
Access Time from $\overline{\text{RAS}}$	t <sub>RAC</sub>	—	60	—	70	—	80	ns	4, 5, 6
Access Time from $\overline{\text{CAS}}$	t <sub>CAC</sub>	—	15	—	20	—	20	ns	4, 5
Access Time from Column Address	t <sub>AA</sub>	—	30	—	35	—	40	ns	4, 6
Access Time from $\overline{\text{CAS}}$ Precharge	t <sub>CPA</sub>	—	35	—	40	—	45	ns	4
Output Low Impedance Time from $\overline{\text{CAS}}$	t <sub>CLZ</sub>	0	—	0	—	0	—	ns	4
Output Buffer Turn-off Delay Time	t <sub>OFF</sub>	0	15	0	20	0	20	ns	7
Transition Time	t <sub>T</sub>	3	50	3	50	3	50	ns	3
Refresh Period	t <sub>REF</sub>	—	16	—	16	—	16	ms	
Refresh Period (L-version)	t <sub>REF</sub>	—	128	—	128	—	128	ms	
RAS Precharge Time	t <sub>RP</sub>	40	—	50	—	60	—	ns	
RAS Pulse Width	t <sub>RAS</sub>	60	10K	70	10K	80	10K	ns	
RAS Pulse Width (Fast Page Mode)	t <sub>RASP</sub>	60	100K	70	100K	80	100K	ns	
RAS Hold Time	t <sub>RSH</sub>	15	—	20	—	20	—	ns	
CAS Precharge Time	t <sub>CP</sub>	10	—	10	—	10	—	ns	
CAS Pulse Width	t <sub>CAS</sub>	15	10K	20	10K	20	10K	ns	
CAS Hold Time	t <sub>CSH</sub>	60	—	70	—	80	—	ns	
CAS to RAS Precharge Time	t <sub>CRP</sub>	5	—	5	—	5	—	ns	
RAS to $\overline{\text{CAS}}$ Delay Time	t <sub>RCD</sub>	20	45	20	50	20	60	ns	5
RAS to Column Address Delay Time	t <sub>RAD</sub>	15	30	15	35	15	40	ns	6
Row Address Set-up Time	t <sub>ASR</sub>	0	—	0	—	0	—	ns	
Row Address Hold Time	t <sub>RAH</sub>	10	—	10	—	10	—	ns	
Column Address Set-up Time	t <sub>ASC</sub>	0	—	0	—	0	—	ns	
Column Address Hold Time	t <sub>CAH</sub>	15	—	15	—	15	—	ns	
Column Address Hold Time from RAS	t <sub>AR</sub>	50	—	55	—	60	—	ns	
Column Address to RAS Lead Time	t <sub>RAL</sub>	30	—	35	—	40	—	ns	

AC Characteristics (2/2)

(V<sub>CC</sub> = 5 V ±10%, T<sub>a</sub> = 0°C to 70°C) Note 1,2,3,9,10

Parameter	Symbol	MSC23236C/CL -60BS20/DS20		MSC23236C/CL -70BS20/DS20		MSC23236C/CL -80BS20/DS20		Unit	Note
		Min.	Max.	Min.	Max.	Min.	Max.		
		Read Command Set-up Time	t <sub>RCS</sub>	0	—	0	—		
Read Command Hold Time	t <sub>RCH</sub>	0	—	0	—	0	—	ns	8
Read Command Hold Time referenced to RAS	t <sub>RRH</sub>	0	—	0	—	0	—	ns	8
Write Command Set-up Time	t <sub>WCS</sub>	0	—	0	—	0	—	ns	
Write Command Hold Time	t <sub>WCH</sub>	10	—	10	—	10	—	ns	
Write Command Hold Time from RAS	t <sub>WCR</sub>	45	—	50	—	60	—	ns	
Write Command Pulse Width	t <sub>WP</sub>	10	—	10	—	10	—	ns	
Write Command to RAS Lead Time	t <sub>RWL</sub>	15	—	20	—	20	—	ns	
Write Command to CAS Lead Time	t <sub>CWL</sub>	15	—	20	—	20	—	ns	
Data-in Set-up Time	t <sub>DS</sub>	0	—	0	—	0	—	ns	
Data-in Hold Time	t <sub>DH</sub>	15	—	15	—	15	—	ns	
Data-in Hold Time from RAS	t <sub>DHR</sub>	50	—	55	—	60	—	ns	
CAS Active Delay Time from RAS Precharge	t <sub>RPC</sub>	5	—	5	—	5	—	ns	
RAS to CAS Set-up Time (CAS before RAS)	t <sub>CSR</sub>	5	—	5	—	5	—	ns	
RAS to CAS Hold Time (CAS before RAS)	t <sub>CHR</sub>	10	—	10	—	10	—	ns	
CAS Precharge Time (Refresh Counter Test)	t <sub>CPT</sub>	30	—	35	—	40	—	ns	
WE to RAS Precharge Time (CAS before RAS)	t <sub>WRP</sub>	10	—	10	—	10	—	ns	
WE Hold Time from RAS (CAS before RAS)	t <sub>WRH</sub>	10	—	10	—	10	—	ns	
RAS to WE Set-up Time (Test Mode)	t <sub>WTS</sub>	10	—	10	—	10	—	ns	
RAS to WE Hold Time (Test Mode)	t <sub>WTH</sub>	10	—	10	—	10	—	ns	

- Notes:
1. A start-up delay of 200  $\mu$ s is required after power-up followed by a minimum of eight initialization cycles ( $\overline{\text{RAS}}$ -only refresh or  $\overline{\text{CAS}}$  before  $\overline{\text{RAS}}$  refresh) before proper device operation is achieved.  
When using the internal refresh counter, a minimum of eight  $\overline{\text{CAS}}$  before  $\overline{\text{RAS}}$  initialization cycles is required.
  2. AC measurement assume  $t_T = 5$  ns.
  3.  $V_{IH}$  (Min.) and  $V_{IL}$  (Max.) are reference levels for measuring input timing signals. Transition times are measured between  $V_{IH}$  and  $V_{IL}$ .
  4. Measured with a load circuit equivalent to 2 TTL loads and 100 pF.
  5. Operation within the  $t_{RCD}$  (Max.) limit ensures that  $t_{RAC}$  (Max.) can be met.  $t_{RCD}$  (Max.) is specified as a reference point only. If  $t_{RCD}$  is greater than the specified  $t_{RCD}$  (Max.) limit, access time is controlled by  $t_{CAC}$ .
  6. Operation within the  $t_{RAD}$  (Max.) limit ensures that  $t_{RAC}$  (Max.) can be met.  $t_{RAD}$  (Max.) is specified as a reference point only. If  $t_{RAD}$  is greater than the specified  $t_{RAD}$  (Max.) limit, access time is controlled by  $t_{AA}$ .
  7.  $t_{OFF}$  (Max.) defines the time at which the output achieves an open circuit condition and is not referenced to output voltage levels.
  8.  $t_{RCH}$  or  $t_{RRH}$  must be satisfied for a read cycle.
  9. The test mode is initiated by performing a  $\overline{\text{WE}}$  and  $\overline{\text{CAS}}$  before  $\overline{\text{RAS}}$  refresh cycle. This mode is latched and remains in effect until the exit cycle is generated.  
In a test mode CA0 is not used and each DQ pin now accesses 2 bit locations. In a read cycle, if the 2 data bits are equal, the DQ pin will indicate a high level. If the 2 data bits are not equal, the DQ pin will indicate a low level.  
The test mode is cleared and the memory device returned to its normal operating state by performing a  $\overline{\text{RAS}}$ -only refresh cycle or a  $\overline{\text{CAS}}$  before  $\overline{\text{RAS}}$  refresh cycle.
  10. In a test mode read cycle, the access time parameters are delayed by 5 ns. The test mode parameters are obtained by adding 5 ns to the normal read cycle values.

**See ADDENDUM E for AC Timing Waveforms**