

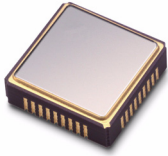

GENERAL DESCRIPTION

The M2006-12A is a VCSO (Voltage Controlled SAW Oscillator) based clock generator PLL designed for clock frequency translation and jitter attenuation. Clock multiplication ratios (including forward and inverse FEC) are pin-selected from pre-programming look-up tables. Includes Hitless Switching and Phase Build-out to enable SONET (GR-253) / SDH (G.813) MTIE and TDEV compliance during reference clock reselection. Hitless Switching (HS) engages when a 4ns or greater clock phase change is detected.



This phase-change triggered implementation of HS is not recommended when using an unstable reference (more than 1ns jitter pk-to-pk) or when the resulting phase detector frequency is less than 5MHz.

PIN ASSIGNMENT (9 x 9 mm SMT)

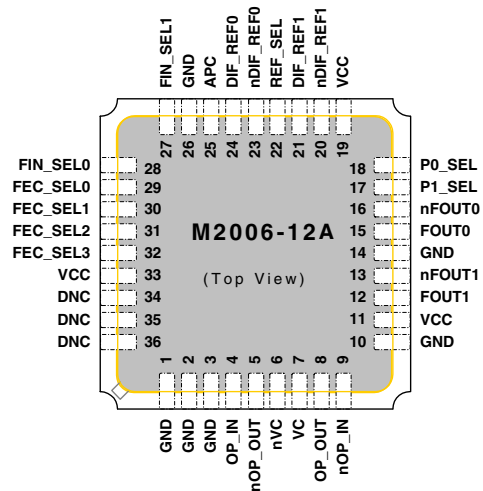

Figure 1: Pin Assignment

FEATURES

- ◆ Reduced intrinsic output jitter and improved power supply noise rejection compared to M2006-12
- ◆ Similar to the M2006-02A - and pin-compatible - but adds Hitless Switching and Phase Build-out functions
- ◆ Includes APC pin for Phase Build-out function (for absorption of the input phase change)
- ◆ Pin-selectable PLL divider ratios support forward and inverse FEC ratio translation
- ◆ Input reference and VCSO frequencies up to 700MHz (Specify VCSO frequency at time of order)
- ◆ Low phase jitter of 0.25 ps rms typical (12kHz to 20MHz or 50kHz to 80MHz)
- ◆ Commercial and Industrial temperature grades
- ◆ Single 3.3V power supply
- ◆ Small 9 x 9 mm SMT (surface mount) package

Example I/O Clock Combinations Using M2006-12A-622.0800

PLL Ratio	Input Clock (MHz)	Output Clock (MHz)
1/1	622.08, 155.52, 77.76, or 19.44	622.08 or 155.52
237/255 (inverse FEC)	669.3266, 167.3316, 83.6658, or 20.9165	155.52

Table 1: Example I/O Clock Combinations Using M2006-12A-622.0800

Using M2006-12A-669.3266

PLL Ratio	Input Clock (MHz)	Output Clock (MHz)
237/255 (FEC rate)	622.08, 155.52, 77.76, or 19.44	669.3266 or 167.3316
1/1	669.3266, 167.3316, 83.6658, or 20.9165	167.3316

Table 2: Example I/O Clock Combinations Using M2006-12A-669.3266

SIMPLIFIED BLOCK DIAGRAM

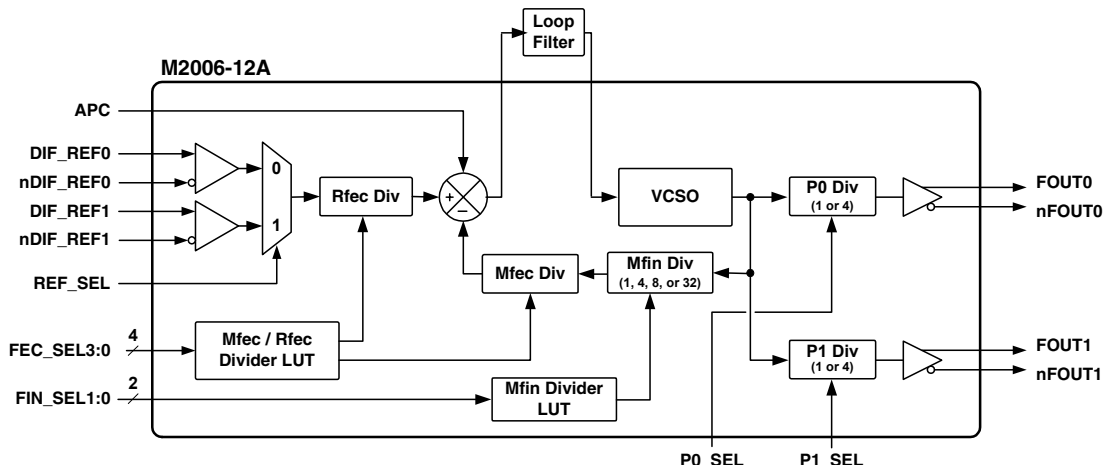

Figure 2: Simplified Block Diagram



DETAILED BLOCK DIAGRAM

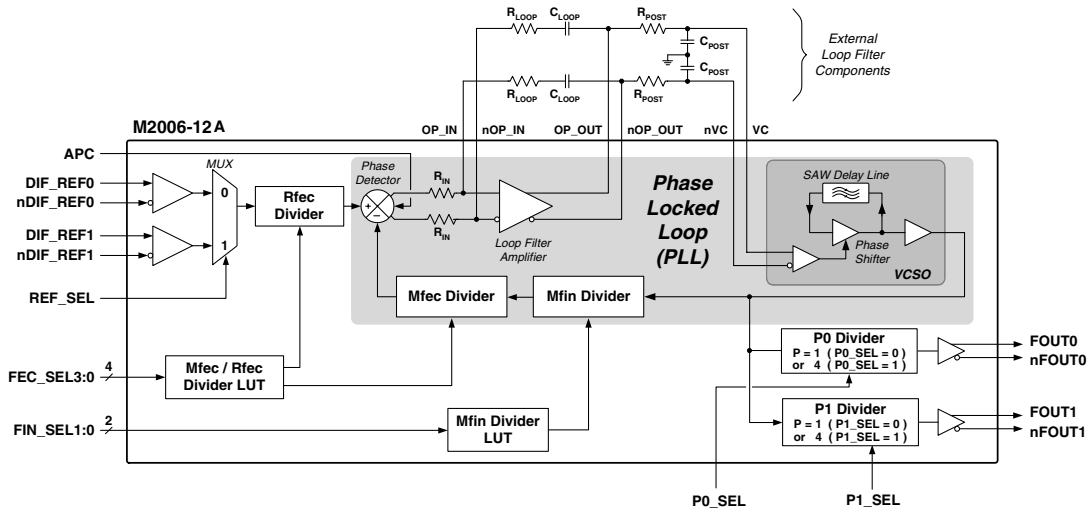

Figure 3: Detailed Block Diagram

PIN DESCRIPTIONS

Number	Name	I/O	Configuration	Description
1, 2, 3, 10, 14, 26	GND	Ground		Power supply ground connections.
4	OP_IN	Input		
9	nOP_IN	Input		
5	nOP_OUT	Output		External loop filter connections. See Figure 4.
8	OP_OUT	Output		
6	nVC	Input		
7	VC	Input		
11, 19, 33	VCC	Power		Power supply connection, connect to +3.3V.
12, 13	FOUT1, nFOUT1	Output	No internal terminator	Clock output pairs. Differential LVPECL.
15, 16	FOUT0, nFOUT0			
17	P1_SEL	Input	Internal pull-down resistor ¹	P Divider controls. LVCMOS/LVTTL. (For P0_SEL, P1_SEL, see Table 6 on pg. 3.)
18	P0_SEL			
20	nDIF_REF1	Input	Internal pull-UP resistor ¹	Reference clock input pair 1. Differential LVPECL or LVDS.
21	DIF_REF1		Internal pull-down resistor ¹	
22	REF_SEL	Input	Internal pull-down resistor ¹	Reference clock input selection. LVCMOS/LVTTL: Logic 1 selects DIF_REF1, nDIF_REF1. Logic 0 selects DIF_REF0, nDIF_REF0.
23	nDIF_REF0	Input	Internal pull-UP resistor ¹	Reference clock input pair 0. Differential LVPECL or LVDS.
24	DIF_REF0		Internal pull-down resistor ¹	
25	APC	Input	Internal pull-down resistor ¹	Automatic Phase Compensation (phase build-out). LVCMOS/LVTTL: Logic 1 - Device absorbs input phase transients. Logic 0 - Device doesn't absorb transients.
27	FIN_SEL1	Input	Internal pull-down resistor ¹	Input clock frequency selection. LVCMOS/LVTTL. (For FIN_SEL1:0, see Table 4 on pg. 3.)
28	FIN_SEL0			
29	FEC_SEL0	Input	Internal pull-UP resistor ¹	FEC PLL divider ratio selection. LVCMOS/LVTTL. (For FEC_SEL3:0, see Table 5 on pg. 3.)
30	FEC_SEL1			
31	FEC_SEL2			
32	FEC_SEL3			
34, 35, 36	DNC		Do Not Connect.	Internal nodes. Connection to these pins can cause erratic device operation.

Table 3: Pin Descriptions



PLL DIVIDER LOOK-UP TABLES

Mfin Divider Look-Up Table (LUT)

The FIN_SEL1:0 pins select the feedback divider value “Mfin” (for Frequency Input).

FIN_SEL1:0		Mfin Value	M2006-12A-622.0800 Sample Ref. Freq. (MHz) †
1	1	1 *	622.08
1	0	4	155.52
0	1	8	77.76
0	0	32	19.44

Table 4: Mfin Divider Look-Up Table (LUT)

Note *: Do not use with FEC_SEL3:0=1100 or 1101 or an excessive phase detector frequency will result.

Note †: Example with M2006-12A-622.0800 and “Non-FEC ratio” selection made from Table 5 (FEC_SEL2=1).

FEC PLL Ratio Dividers Look-up Table (LUT)

The FEC_SEL3:0 pins select the FEC feedback and reference divider values Mfec and Rfec.

FEC_SEL3:0	Mfec	Rfec ¹	Description
0 0 0 0	236	255	Inverse FEC ratio
0 0 0 1	79	85	Inverse FEC ratio, equivalent to 237/255
0 0 1 0	14	15	Inverse FEC ratio, equivalent to 238/255
0 0 1 1	239	255	Inverse FEC ratio
0 1 0 0	236	236	Non-FEC ratio, complements 0000 or 1000 ²
0 1 0 1	79	79	Non-FEC ratio, complements 0001 or 1001 ²
0 1 1 0	14	14	Non-FEC ratio, complements 0010 or 1010 ²
0 1 1 1	239	239	Non-FEC ratio, complements 0011 or 1011 ²
1 0 0 0	255	236	FEC ratio (OTU3)
1 0 0 1	85	79	FEC ratio, equivalent to 255/237 (OTU2)
1 0 1 0	15	14	FEC ratio, equivalent to 255/238 (OTU1)
1 0 1 1	255	239	FEC ratio
1 1 0 0	1	1	Non-FEC ratio ³ Do not use these two settings with FIN_SEL1:0=11
1 1 0 1	2	2	
1 1 1 0	4	4	Non-FEC ratio ³
1 1 1 1	8	8	

Table 5: FEC PLL Ratio Dividers Look-up Table (LUT)

Note 1: The phase detector frequency (Fpd, which is calculated as Fref/Rfec) should be above 1.5 MHz to prevent spurs on the output clock. To ensure the PLL remains locked when using a recovered clock (such as in loop timing mode), the phase detector frequency should ideally be about 20MHz, or at least less than 50 MHz.

Note 2: These table selections use the same or similar Mfec divider values as the complementary selections noted. This allows the use of the same loop filter component values and yields the same PLL loop bandwidth and damping factor values for complementary selections. Complementary selections can be actively switched in a given application.

Note 3: In non-FEC applications, these settings can be used to optimize phase detector frequency or to actively change PLL loop bandwidth.

Post-PLL Dividers

The M2006-12A also features two post-PLL dividers, one for each output pair. The “P1” divider is for FOUT1 and nFOUT1; the “P0” divider is for FOUT0 and nFOUT0.

Each divides the VCSO frequency to produce one of two output frequencies (1/4 or 1/1 of the VCSO frequency). The P1_SEL and P0_SEL pins each select the value for their corresponding divider.

P1_SEL, P0_SEL	P Value	M2006-12A-622.0800 Sample Output Frequency (MHz)
1	4	155.52
0	1	622.08

Table 6: P Divider Selector, Values, and Frequencies

FUNCTIONAL DESCRIPTION

The M2006-12A is a PLL (Phase Locked Loop) based clock generator that generates output clocks synchronized to one of two selectable input reference clocks.

An internal high "Q" SAW filter provides low jitter signal performance and controls the output frequency of the VCSO (Voltage Controlled SAW Oscillator).

Configurable FEC feedback and reference dividers (the “Mfec Divider” and “Rfec Divider”) provide the multiplication ratios necessary to accommodate clock translation for both forward and inverse Forward Error Correction.

In addition, a configurable feedback divider (labeled “Mfin Divider”) provides the broader division options needed to accommodate various reference clock frequencies.

For example, the M2006-12A-622.0800 (see “Ordering Information” on pg. 10) has a 622.08MHz VCSO frequency:

- The inverse FEC PLL ratios (at top of Table 5) enable the M2006-12A-622.0800 to accept “base” input reference frequencies of: 663.7255, 666.5143, 669.3266, 672.1627, and 622.08MHz.
- The Mfin feedback divider enables the actual input reference clock to be the “base” input frequency divided by 1, 4, 8, or 32. Therefore, for the base input frequency of 622.08MHz, the actual input reference clock frequencies can be: 622.08, 155.52, 77.76, and 19.44MHz. (See Table 4 on pg. 3.)



The PLL

The PLL uses a phase detector and configurable dividers to synchronize the output of the VCSO with selected reference clock.

The “Mfin Divider” and “Mfec Divider” divide the VCSO frequency, feeding the result into the phase detector.

The selected input reference clock is divided by the “Rfec Divider”. The result is fed into the other input of the phase detector.

The phase detector compares its two inputs. It then outputs pulses to the loop filter as needed to increase or decrease the VCSO frequency and thereby match and lock the divider output’s frequency and phase to those of the input reference clock.

Due to the narrow tuning range of the VCSO ($\pm 200\text{ppm}$), appropriate selection of all of the following are required for the PLL be able to lock: VCSO center frequency, input frequency, and divider selections.

See also “Maintaining PLL Lock:” on pg. 4.

Relationship Among Frequencies and Dividers

The VCSO center frequency must be specified at time of order. The relationship between the VCSO (Fvcso) frequency, the Mfin divider, the Mfec divider, the Rfec divider, and the input reference frequency (Fin) is:

$$F_{vcso} = F_{in} \times M_{fin} \times \frac{M_{fec}}{R_{fec}}$$

As an example, for the M2006-12A-622.0800, the non-FEC and inverse-FEC PLL ratios in Table 5 enable use with these corresponding input reference frequencies:

M2006-12A-622.0800 VCSO Clock Frequency (MHz) ÷	FEC Ratio	M2006-12A-622.0800 Base Input Ref. = Frequency (MHz) ¹
622.08	1 / 1	622.0800
	238 / 255	666.5143
	237 / 255	669.3266
	236 / 255	672.1627

Table 7: Example FEC PLL Ratios and Input Reference Frequencies
Note 1: Input reference clock (“Fin”) can be the base frequency shown divided by “Mfin” (as shown in Table 4 on pg. 3).

Maintaining PLL Lock:

The narrow tuning range of the VCSO requires that the input reference frequency must remain suitable for the current look-up table selection. For example, when switching between “Inverse FEC ratio” and “Non-FEC ratio” look-up table selections (see Table 5 on pg. 3), the input reference frequency must change accordingly in order for the PLL to lock.

An out-of-lock condition due to an inappropriate configuration will typically result in the VCSO operating at its lower or upper frequency rail, which is approximately 200ppm above or below the nominal VCSO center frequency.

See also “Hitless Switching (HS)” (next) for an additional issue with regard to phase locking.

Hitless Switching (HS)

The M2006-12A includes a proprietary Hitless Switching (HS) feature that prevents an excessive phase transient of the output clocks upon input reference rearrangement. Upon the occurrence of an input reference phase change, or phase transient, PLL bandwidth is lowered by the HS function. This limits the rate of phase change in the output clocks. With proper configuration of the external loop filter, the output clocks will comply with MTIE (maximum time interval error) specifications for GR-253 (SONET) and ITU G.813 (SDH) during input reference clock change, depending on the magnitude of the resulting phase change.

The HS function uses a phase error detector at the phase detector to detect a clock phase change. During normal operation with a stable reference clock, the PLL will be frequency locked and phase locked, resulting in very little error at the phase detector (<1 ns). Upon the selection of a new input reference clock at a different clock phase, a phase error will occur at the phase detector. The HS function is triggered with a phase error greater than 4 ns, upon which a narrow PLL bandwidth is applied. When the PLL locks to within 2 ns error at the phase detector, wide bandwidth (normal) operation is resumed.

The HS function is not suitable for situations in which an unstable reference is used. Under normal conditions the reference clock jitter should not induce phase jitter at the phase detector beyond 2 ns. (This includes when subjecting the system to jitter tolerance compliance testing.) Because of this, the M2006-12A is not recommended for use with some Stratum DPLL clock sources, or with unstable recovered network clocks intended for loop timing configuration. It is also not recommended for complex FEC ratios where the phase detector is operated at less 1 MHz. For these applications the M2006-02A is suggested. The M2006-02A is identical to the M2006-12A except that it does not include the HS function (nor the APC pin and phase build-out function, which are discussed in the following section).



Automatic Phase Compensation (APC) Pin

The M2006-12A also includes a phase build-out function that can be selectively enabled by asserting the APC input (pin 25) to logic 1. The phase build-out function works in conjunction with the HS function. When the APC pin is asserted, the phase build-out function enables the PLL to absorb most of the phase change of the input clock which reduces re-lock time and the generation of wander. (Wander is created in this case by the generation of extra output clock cycles.)

When the APC pin is asserted, the phase build-out function is triggered by same >4 ns phase transient (at the phase detector) that triggers the HS function. Once triggered, a new VCSO clock edge is selected for the phase comparator feedback input. (The clock edge selected is the one closest in phase to the new input clock phase.) The residual phase detector phase error following reselection is approximately 3-to-4 ns. The narrow bandwidth selected by HS minimizes VCSO drifting and switch transients during the process.

It is recommended that the APC pin remain low when the phase detector frequency is less than 4 MHz. Otherwise, the M2006-12A may have difficulty locking to reference upon power-up.

Outputs

The M2006-12A provides a total of two differential LVPECL output pairs: FOUT1 and FOUT0. Because each output pair has its own P divider, the FOUT1 pair and the FOUT0 can output the two different frequencies at the same time. For example, FOUT1 can output 155.52MHz while FOUT0 outputs 622.08MHz.

Any unused output should be left unconnected (floating) in the system application. This will minimize output switching current and therefore minimize noise modulation of the VCSO.

External Loop Filter

To provide stable PLL operation, and thereby a low jitter output clock, the M2006-12A requires the use of an external loop filter. This is provided via the provided filter pins (see Figure 4).

Due to the differential signal path design, the implementation requires two identical complementary RC filters as shown here.

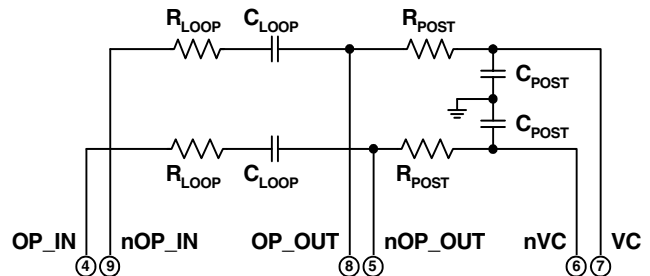

Figure 4: External Loop Filter

See Example External Loop Filter Component Values table.

PLL bandwidth is affected by loop filter component values, "Mfec" and "Mfin" values, and the "PLL Loop Constants" listed in AC Characteristics on pg. 8.

The various "Non-FEC ratio" settings can be used to actively change PLL loop bandwidth in a given application. See "FEC PLL Ratio Dividers Look-up Table (LUT)" on pg. 3.

PLL Simulator Tool Available

A free PC software utility is available on the ICS website (www.icst.com). The M2000 Timing Modules PLL Simulator is a downloadable application that simulates PLL jitter and wander transfer characteristics. This enables the user to set appropriate external loop component values in a given application.

Go to the SAW PLL Simulator Software web page at www.icst.com/products/calculators/m2000filterSWdesc.htm

Example External Loop Filter Component Values¹

VCSO Parameters: $K_{VCO} = 800\text{kHz/V}$, $R_{IN} = 50\text{k}\Omega$, VCSO Bandwidth = 700kHz.

F _{Ref} (MHz)	Device Configuration			Example External Loop Filter Component Values				Nominal Performance Using These Values		
	F _{VCSO} (MHz)	FIN_SEL1:0 pins	FEC_SEL3:0 pins	R loop	C loop	R post	C post	PLL Loop Bandwidth	Damping Factor	Passband Peaking (dB)
19.44	622.08	0 0	1 1 0 0	11.5kΩ	2.2μF	34kΩ	470pF	1kHz	6.0	0.05
77.76		0 1	1 1 1 0							
155.52		1 0	1 1 1 1							
622.08		1 1	0 1 1 0	5.11kΩ	4.7μF	6.0	0.06			
167.3317		1 0	0 0 0 1	113.0kΩ	0.22μF					
669.3266		1 1		28.0kΩ	1.0μF					
155.52	669.3266	1 0	1 0 0 1	121.0kΩ	0.22μF	6.0	0.05			
622.08		1 1		30.1kΩ	1.0μF	6.5	0.05			

Table 8: Example External Loop Filter Component Values

Note 1: K_{VCO} , VCSO Bandwidth, M Divider Value, and External Loop Filter Component Values determine Loop Bandwidth, Damping Factor, and Passband Peaking. For PLL Simulator software, go to www.icst.com.



ABSOLUTE MAXIMUM RATINGS¹

Symbol	Parameter	Rating	Unit
V _I	Inputs	-0.5 to V _{CC} +0.5	V
V _O	Outputs	-0.5 to V _{CC} +0.5	V
V _{CC}	Power Supply Voltage	4.6	V
T _S	Storage Temperature	-45 to +100	°C

Table 9: Absolute Maximum Ratings

Note 1: Stresses beyond those listed under Absolute Maximum Ratings may cause permanent damage to the device. These ratings are stress specifications only. Functional operation of product at these conditions or any conditions beyond those listed in Recommended Conditions of Operation, DC Characteristics, or AC Characteristics is not implied. Exposure to absolute maximum rating conditions for extended periods may affect product reliability.

RECOMMENDED CONDITIONS OF OPERATION

Symbol	Parameter	Min	Typ	Max	Unit
V _{CC}	Positive Supply Voltage	3.135	3.3	3.465	V
T _A	Ambient Operating Temperature	Commercial	0	+70	°C
		Industrial	-40	+85	°C

Table 10: Recommended Conditions of Operation



ELECTRICAL SPECIFICATIONS

DC Characteristics

Unless stated otherwise, $V_{CC} = 3.3V \pm 5\%$, $T_A = 0^\circ C$ to $+70^\circ C$ (commercial), $T_A = -40^\circ C$ to $+85^\circ C$ (industrial), $F_{VCSO} = F_{OUT} = 622-675MHz$, LVPECL outputs terminated with 50Ω to $V_{CC} - 2V$

	Symbol	Parameter		Min	Typ	Max	Unit	Conditions
Power Supply	V_{CC}	Positive Supply Voltage		3.135	3.3	3.465	V	
	I_{CC}	Power Supply Current			175	225	mA	
All Differential Inputs	V_{P-P}	Peak to Peak Input Voltage		0.15			V	
	V_{CMR}	Common Mode Input	DIF_REF0, nDIF_REF0, DIF_REF1, nDIF_REF1	0.5		$V_{CC} - .85$	V	
	C_{IN}	Input Capacitance				4	pF	
Differential Inputs with Pull-down	I_{IH}	Input High Current (Pull-down)				150	μA	$V_{CC} = V_{IN} = 3.456V$
	I_{IL}	Input Low Current (Pull-down)	DIF_REF0, DIF_REF1	-5			μA	
	$R_{pulldown}$	Internal Pull-down Resistance			50		k Ω	
Differential Inputs with Pull-up	I_{IH}	Input High Current (Pull-up)				5	μA	$V_{IN} = 0$ to $3.456V$
	I_{IL}	Input Low Current (Pull-up)	nDIF_REF0, nDIF_REF1	-150			μA	
	R_{pullup}	Internal Pull-up Resistance			50		k Ω	
All LVCMOS / LVTTTL Inputs	V_{IH}	Input High Voltage	APC, REF_SEL, FIN_SEL1, FIN_SEL0, FEC_SEL3,	2		$V_{CC} + 0.3$	V	
	V_{IL}	Input Low Voltage	FEC_SEL2, FEC_SEL1, FEC_SEL0, P1_SEL, P0_SEL	-0.3		0.8	V	
	C_{IN}	Input Capacitance				4	pF	
LVCMOS / LVTTTL Inputs with Pull-down	I_{IH}	Input High Current (Pull-down)				150	μA	$V_{CC} = V_{IN} = 3.456V$
	I_{IL}	Input Low Current (Pull-down)	REF_SEL, FIN_SEL1, FIN_SEL0, P1_SEL, P0_SEL	-5			μA	
	$R_{pulldown}$	Internal Pull-down Resistance			50		k Ω	
LVCMOS / LVTTTL Inputs with Pull-up	I_{IH}	Input High Current (Pull-up)				5	μA	$V_{CC} = 3.456V$ $V_{IN} = 0 V$
	I_{IL}	Input Low Current (Pull-up)	FEC_SEL3, FEC_SEL2, FEC_SEL1, FEC_SEL0	-150			μA	
	R_{pullup}	Internal Pull-up Resistance			50		k Ω	
Differential Outputs	V_{OH}	Output High Voltage		$V_{CC} - 1.4$		$V_{CC} - 1.0$	V	
	V_{OL}	Output Low Voltage	FOUT0, nFOUT0, FOUT1, nFOUT1	$V_{CC} - 2.0$		$V_{CC} - 1.7$	V	
	V_{P-P}	Peak to Peak Output Voltage ¹		0.4		0.85	V	

Note 1: Single-ended measurement. See Figure 5, Output Rise and Fall Time, on pg. 8.

Table 11: DC Characteristics



ELECTRICAL SPECIFICATIONS (CONTINUED)

AC Characteristics

Unless stated otherwise, $V_{CC} = 3.3V \pm 5\%$, $T_A = 0^\circ C$ to $+70^\circ C$ (commercial), $T_A = -40^\circ C$ to $+85^\circ C$ (industrial), $F_{VCSO} = F_{OUT} = 622\text{-}675\text{MHz}$, LVPECL outputs terminated with 50Ω to $V_{CC} - 2V$

	Symbol	Parameter		Min	Typ	Max	Unit	Test Conditions
Input Frequency Range	F_{IN}	Input Frequency	DIF_REF0, nDIF_REF0, DIF_REF1, nDIF_REF1	10		700	MHz	
Output Frequency Range	F_{FOUT}	Output Frequency Range	FOUT0, nFOUT0, FOUT1, nFOUT1	100		700	MHz	
	APR	VCSO Pull-Range	Commercial	± 120	± 200		ppm	
			Industrial	± 50	± 150		ppm	
PLL Loop Constants ¹	K_{VCO}	VCO Gain			800		kHz/V	
	R_{IN}	Internal Loop Resistor			50		k Ω	
	BW_{VCSO}	VCSO Bandwidth			700		kHz	
Phase Noise and Jitter	Φ_n	Single Side Band Phase Noise @ 622.08MHz	1kHz Offset		-72		dBc/Hz	$F_{in}=19.44\text{ MHz}$ $M_{fin}=32, M_{fec}=1, R_{fec}=1$
			10kHz Offset		-94		dBc/Hz	
			100kHz Offset		-123		dBc/Hz	
	J(t)	Jitter (rms) @ 622.08MHz	12kHz to 20MHz		0.25	0.5	ps rms	
50kHz to 80MHz				0.25	0.5	ps rms		
t_{PW}	Output Duty Cycle ² FOUT0, nFOUT0, FOUT1, nFOUT1	P0, P1 = 1		40	50	60	%	
		P0, P1 = 4		45	50	55	%	
t_R	Output Rise Time ²	FOUT0, nFOUT0, FOUT1, nFOUT1		200	450	500	ps	20% to 80%
t_F	Output Fall Time ²	FOUT0, nFOUT0, FOUT1, nFOUT1		200	450	500	ps	20% to 80%

Table 12: AC Characteristics

Note 1: Parameters needed for PLL Simulator software; see PLL Simulator Tool Available on pg. 5.

Note 2: See Parameter Measurement Information on pg. 8.

PARAMETER MEASUREMENT INFORMATION

Output Rise and Fall Time

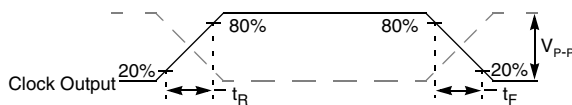

Figure 5: Output Rise and Fall Time

Output Duty Cycle

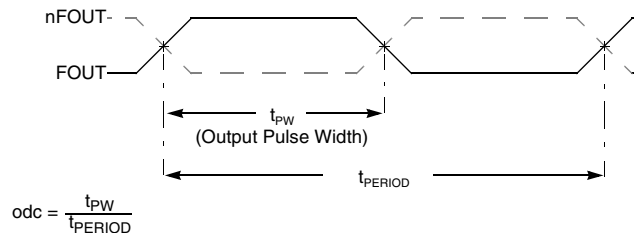
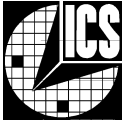
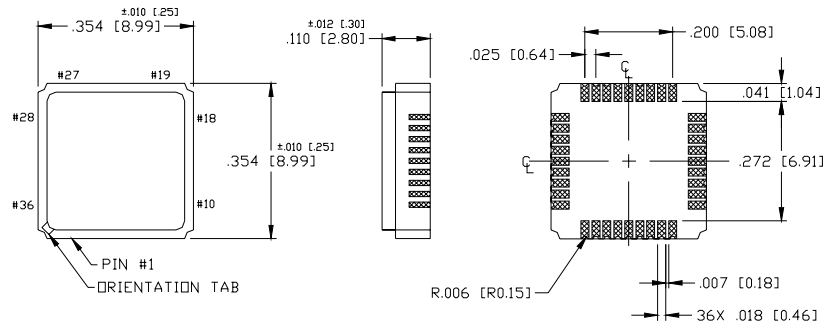

Figure 6: Output Duty Cycle



DEVICE PACKAGE - 9 x 9mm CERAMIC LEADLESS CHIP CARRIER

Mechanical Dimensions:



Refer to the SAW PLL application notes web page at www.icst.com/products/appnotes/SawPllAppNotes.htm for application notes, including recommended PCB footprint, solder mask, and furnace profile.

NOTES:

1. DIMENSIONS ARE IN INCHES, DIMENSIONS IN [] ARE MM.
2. UNLESS OTHERWISE SPECIFIED ALL DIMENSIONS ARE $\pm .005$ [0.13]

Figure 7: Device Package - 9 x 9mm Ceramic Leadless Chip Carrier



ORDERING INFORMATION

Part Numbering Scheme

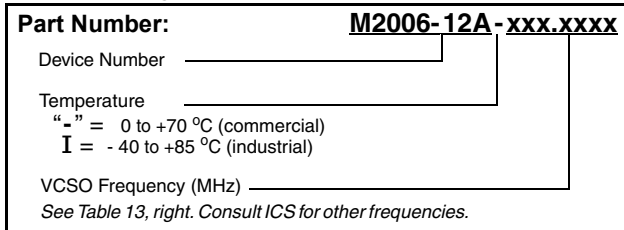

Figure 8: Part Numbering Scheme

Standard VCSO Output Frequencies (MHz)*

Consult ICS for the availability of other VCSO frequencies

622.0800	669.3120
625.0000	669.3266
627.3296	669.6429
644.5313	670.8386
666.5143	672.1600
669.1281	690.5692

Table 13: Standard VCSO Output Frequencies (MHz)

Note *: Fout can equal Fvcso divided by: 1 or 4

Consult ICS for the availability of other PLL frequencies.

Example Part Numbers

PLL Frequency (MHz)	Temperature	Order Part Number
622.08	commercial	M2006-12A-622.0800
	industrial	M2006-12AI622.0800
625.00	commercial	M2006-12A-625.0000
	industrial	M2006-12AI625.0000
669.3266	commercial	M2006-12A-669.3266
	industrial	M2006-12AI669.3266
669.6429	commercial	M2006-12A-669.6429
	industrial	M2006-12AI669.6429

Table 14: Example Part Numbers