

Hi-Reliability GaAlAs Infrared Emitting Diodes

Types OP235TX, OP235TXV, OP236TX, OP236TXV

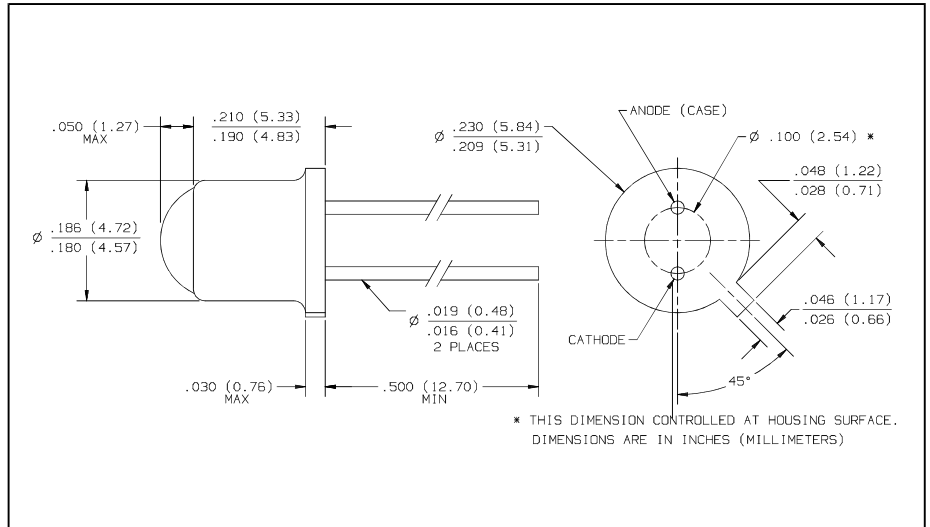

Features

- Twice the power output of GaAs at the same drive current
- Characterized to define infrared energy along the mechanical axis of the device
- Mechanically and spectrally matched to the OP804TX/TXV and OP805TX/TXV phototransistors
- Screened per MIL-PRF-19500 TX or TXV equivalent levels

Description

The OP235TX, TXV and OP236TX, TXV are high reliability gallium aluminum arsenide infrared emitting diodes mounted in hermetic TO-46 packages. The wavelength is centered at 890 nanometers to closely match the spectral response of silicon phototransistors. Devices are processed to Optek's 100% screening and quality conformance program patterned after MIL-PRF-19500. After 100% screening, Group A and B are performed on every lot, and a Group C test is performed every six months.

The OP235TX, TXV and OP236TX, TXV have lens cans providing a narrow beam angle (18° between half power points). The narrow beam angle and the specified radiant intensity allow ease of design in beam interrupt applications with the OP804TX, TXV and OP805TX, TXV series of high reliability phototransistors.

Absolute Maximum Ratings ($T_A = 25^\circ\text{C}$ unless otherwise noted)

Forward DC Current	100 mA
Reverse Voltage	2.0 V
Operating Temperature	-55° C to +125° C
Storage Temperature	-65° C to +150° C
Lead Soldering Temperature [1/16 inch (1.6mm) from case for 5 sec. with soldering iron]	240° C ⁽¹⁾
Power Dissipation	200 mW ⁽²⁾

Notes:

- (1) RMA flux is recommended. Duration can be extended to 10 seconds max. when flow soldering.
- (2) Derate linearly 2.00 mW/° C above 25° C.
- (3) $E_{e(APT)}$ is a measurement of the average radiant intensity within the cone formed by the measurement surface. The cone is outlined by a radius of 1.429 inches (36.30 mm) measured from the lens side of the tab to the sensing surface and a sensing surface of 0.250 inches (6.35 mm) in diameter forming a 10° cone. $E_{e(APT)}$ is not necessarily uniform within the measured area.

Typical screening and lot acceptance tests are provided on page 13-4.

Types OP235TX, OP235TXV, OP236TX, OP236TXV

Electrical Characteristics ($T_A = 25^\circ\text{C}$ unless otherwise noted)

Symbol	Parameter	Min	Typ	Max	Units	Test Conditions (3)
$E_{e(\text{APT})}$	Apertured Radiant Incidence ^(3,4) OP235TX, TXV OP236TX, TXV	1.5 3.5			mW/cm^2 mW/cm^2	$I_F = 100\text{ mA}$ $I_F = 100\text{ mA}$
V_F	Forward Voltage ⁽⁶⁾	1.1 1.3 0.9		2.0 2.2 1.8	V V V	$I_F = 100\text{ mA}$ $I_F = 100\text{ mA}, T_A = -55^\circ\text{C}$ $I_F = 100\text{ mA}, T_A = 100^\circ\text{C}$
I_R	Reverse Current			100	μA	$V_R = 2.0\text{ V}$
λ_p	Wavelength at Peak Emission		890		nm	$I_F = 100\text{ mA}$
B	Spectral Bandwidth Between Half Power Points		50		nm	$I_F = 100\text{ mA}$
θ_{HP}	Emission Angle at Half Power Points		18.0		Deg.	$I_F = 100\text{ mA}$

HI-RELE OPTO
COMPONENTS

Optek reserves the right to make changes at any time in order to improve design and to supply the best product possible.

Optek Technology, Inc. 1215 W. Crosby Road Carrollton, Texas 75006 (972)323-2200 Fax (972)323-2396