

# DATA SHEET

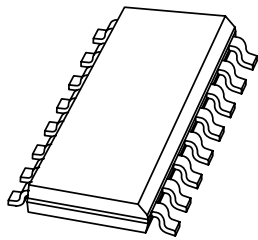

## **KMZ52** Magnetic Field Sensor

Product specification

2000 Jun 09

# Magnetic Field Sensor

# KMZ52

### FEATURES

- High sensitivity
- Integrated compensation coil
- Integrated set/reset coil.

### APPLICATIONS

- Navigation
- Current and earth magnetic field measurement
- Traffic detection.

### DESCRIPTION

The KMZ52 is an extremely sensitive magnetic field sensor, employing the magnetoresistive effect of thin-film permalloy. The sensor contains two magnetoresistive Wheatstone bridges physically offset from one another by 90° and integrated compensation and set/reset coils. The integrated compensation coils allow magnetic field measurement with current feedback loops to generate outputs that are independent of drift in sensitivity. The orientation of sensitivity may be set or changed (flipped) by means of the integrated set/reset coils. A short current pulse should be applied to the compensation coils to recover (set) the sensor after exposure to strong disturbing magnetic fields. A negative current pulse will reset the sensor to reversed sensitivity. By use of periodically alternated flipping pulses and a lock-in amplifier, the output is made independent of sensor and amplifier offset.

### PINNING

SYMBOL	PIN	DESCRIPTION
+I <sub>flip2</sub>	1	flip coil
V <sub>CC2</sub>	2	bridge supply voltage
GND2	3	ground
+I <sub>comp2</sub>	4	compensation coil
GND1	5	ground
+I <sub>comp1</sub>	6	compensation coil
-I <sub>comp1</sub>	7	compensation coil
-V <sub>O1</sub>	8	bridge output voltage
+V <sub>O1</sub>	9	bridge output voltage
-I <sub>flip1</sub>	10	flip coil
+I <sub>flip1</sub>	11	flip coil
V <sub>CC1</sub>	12	bridge supply voltage
-I <sub>comp2</sub>	13	compensation coil
-V <sub>O2</sub>	14	bridge output voltage
+V <sub>O2</sub>	15	bridge output voltage
-I <sub>flip2</sub>	16	flip coil

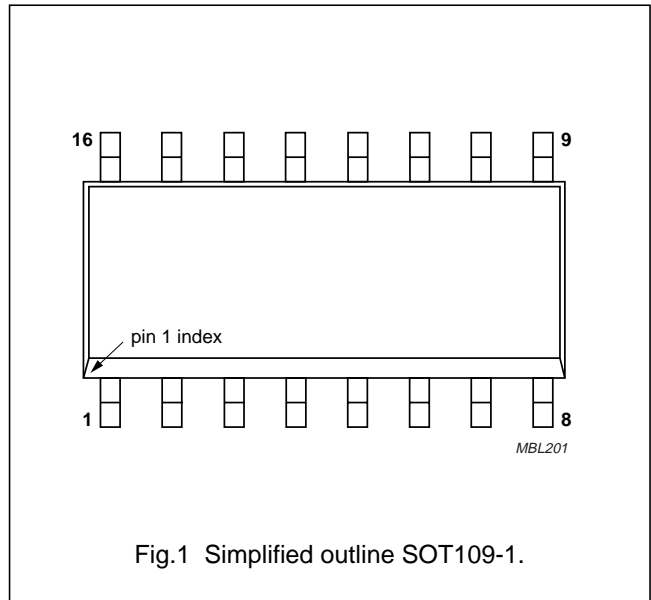

## Magnetic Field Sensor

KMZ52

## QUICK REFERENCE DATA

SYMBOL	PARAMETER	MIN.	TYP.	MAX.	UNIT
V <sub>CC</sub>	bridge supply voltage	–	5	8	V
S	sensitivity (uncompensated)	12	16	–	$\frac{\text{mV/V}}{\text{kA/m}}$
V <sub>offset</sub>	offset voltage per supply voltage	–1.5	0	+1.5	mV/V
R <sub>bridge</sub>	bridge resistance	1	2	3	kΩ
R <sub>comp</sub>	compensation coil resistance	100	170	300	Ω
A <sub>comp</sub>	field factor of compensation coil; note 1	19	22	25	$\frac{\text{A/m}}{\text{mA}}$
R <sub>flip</sub>	resistance of set/reset coil	1	2	3	Ω
I <sub>flip</sub>	recommended flipping current for stable operation; note 2	±800	±1000	±1200	mA
t <sub>flip</sub>	flip pulse duration; note 2	1	3	100	μs

## Notes

1. The compensation coil generates a field  $H_{\text{comp}} = A_{\text{comp}} \times I_{\text{comp}}$  in addition to the external field  $H_{\text{ext}}$ . Sensor output will become zero if  $H_{\text{ext}} = H_{\text{comp}}$ .
2. Average power consumption of the flipping coil, defined by current, pulse duration and pulse repetition rate may not exceed the specified limit, see Chapter “Limiting values”.

## LIMITING VALUES

In accordance with the Absolute Maximum System (IEC 60134).

SYMBOL	PARAMETER	MIN.	MAX.	UNIT
V <sub>CC</sub>	bridge supply voltage	–	8	V
P <sub>tot</sub>	total power dissipation	–	130	mW
T <sub>stg</sub>	storage temperature	–65	+150	°C
T <sub>amb</sub>	maximum operating temperature	–40	–125	°C
I <sub>comp</sub>	maximum compensation current	–	15	mA
I <sub>flip (max)</sub>	maximum flipping current	–	1500	mA
P <sub>flip (max)</sub>	maximum flipping power dissipation	–	50	mW
V <sub>isol</sub>	voltage between isolated systems: flip coil and Wheatstone bridge; compensation coil and Wheatstone bridge; flip coil and compensation coil	–	60	V

## THERMAL CHARACTERISTICS

SYMBOL	PARAMETER	VALUE	UNIT
R <sub>th j-a</sub>	terminal resistance from junction to ambient	105	K/W

## Magnetic Field Sensor

## KMZ52

## CHARACTERISTICS

$T_{\text{bridge}} = 25\text{ °C}$ ;  $V_{\text{CC1}} = V_{\text{CC2}} = 5\text{ V}$ ; unless otherwise specified.

SYMBOL	PARAMETER	CONDITIONS	MIN.	TYP.	MAX.	UNIT
$V_{\text{CC}}$	bridge supply voltage	note 1	–	5	8	V
H	field strength operating range in sensor plane		–0.2	–	+0.2	kA/m
S	sensitivity	open circuit	12	16	–	$\frac{\text{mV/V}}{\text{kA/m}}$
TCS	temperature coefficient of sensitivity	$T_{\text{s}} = -25\text{ to }+125\text{ °C}$	–	0.31	–	%/K
$k_{\text{SX}}$	sensitivity synchronism	note 2	92	100	108	%
$\text{TCV}_{\text{O}}$	temperature coefficient of output voltage	$V_{\text{CC}} = 5\text{ V}$ ; $T_{\text{bridge}} = -25\text{ to }+125\text{ °C}$	–	–0.4	–	%/K
$R_{\text{bridge}}$	bridge resistance	note 3	1	2	3	k $\Omega$
$\text{TCR}_{\text{bridge}}$	temperature coefficient of bridge resistance	$T_{\text{bridge}} = -25\text{ to }+125\text{ °C}$ ; note 4	–	0.3	–	%/K
$V_{\text{offset}}$	offset voltage per supply voltage		–1.5	0	+1.5	mV/V
$\text{TCV}_{\text{offset}}$	temperature coefficient of offset voltage	$T_{\text{bridge}} = -25\text{ to }+125\text{ °C}$ ; note 5	–3	0	+3	$\frac{\mu\text{V/V}}{\text{K}}$
FH	hysteresis of output voltage		–	–	2	%FS
$R_{\text{comp}}$	resistance of compensation coil	note 6	100	170	300	$\Omega$
$A_{\text{comp}}$	field factor of compensation coil		19	22	25	$\frac{\text{A/m}}{\text{mA}}$
$R_{\text{flip}}$	resistance of set/reset coil	note 7	1	2	3	$\Omega$
$\text{TCR}_{\text{flip}}$	temperature coefficient of resistance of set/reset coil	$T_{\text{flip}} = -25\text{ to }+125\text{ °C}$	–	0.39	–	%/K
$I_{\text{flip}}$	recommended flipping current for stable operation		$\pm 800$	$\pm 1000$	$\pm 1200$	mA
$t_{\text{flip}}$	flip pulse duration		1	3	100	$\mu\text{s}$
$R_{\text{isol}}$	isolating resistance	note 8	1	–	–	M $\Omega$
$V_{\text{isol}}$	voltage between isolated systems	note 8	–	–	50	V
$R_{\text{isol\_dice}}$	isolating resistance between dice	die 1 to die 2	1	–	–	M $\Omega$
f	operating frequency		0	–	1	MHz
$\alpha$	angle die-to-die	note 9	88	90	92	deg
$\beta$	angle dice-to-package	note 9	–5	0	+5	deg

## Notes

1. Due to the ratiometric output, the same supply voltage ( $V_{\text{CC}}$ ) must be applied to both dice in one KMZ52 device.

$$2. k_{\text{SX}} = 100 \times \frac{A_{\text{comp1}} \times S_1}{A_{\text{comp2}} \times S_2} \%$$

3. Bridge resistance die 1: between pins 5 and 12; bridge resistance die 2: between pins 2 and 3.

$$4. \text{TCR}_{\text{bridge}} = 100 \frac{R_{\text{bridge}(T_2)} - R_{\text{bridge}(T_1)}}{R_{\text{bridge}(T_1)} (T_2 - T_1)} \quad \text{Where } T_1 = -25\text{ °C}; T_2 = 125\text{ °C}.$$

---

## Magnetic Field Sensor

KMZ52

---

5.  $TCV_{\text{offset}} = \frac{V_{\text{offset}(T_2)} - V_{\text{offset}(T_1)}}{(T_2 - T_1)}$       Where  $T_1 = -25^\circ\text{C}$ ;  $T_2 = 125^\circ\text{C}$  .
6. Resistance of compensation coil die 1: between pins 6 and 7;  
resistance of compensation coil die 2: between pins 4 to 13.
7. Resistance of set/reset coil die 1: between pins 10 and 11;  
resistance of set/reset coil die 2: between pins 1 to 16.
8. Isolating resistance die 1: pins 7 and 8, 7 and 10 and 8 to 10;  
isolating resistance die 2: pins 1 to 2, 1 to 4 and 2 to 4.
9. Angle die-to-die: die 2 is turned by  $90 \pm 2$  degrees in anticlockwise direction with respect to die 1;  
angle dice-to-package: both dice in their fixed die-to-die position are tilted towards the package edges by  $0 \pm 5$  degrees.

# Magnetic Field Sensor

KMZ52

## APPLICATION INFORMATION

If the angle  $\alpha$  between external magnetic field  $H$  and the long axis of the package is zero,  $H$  is parallel to the most sensitive direction of die 2 and perpendicular to the sensitive direction of die 1. A magnetic field turning clockwise (see Fig.2) thus yields an output proportional to  $\cos \alpha$  ( $V_{out2}$ ) and an output proportional to  $\sin \alpha$  ( $V_{out1}$ ).

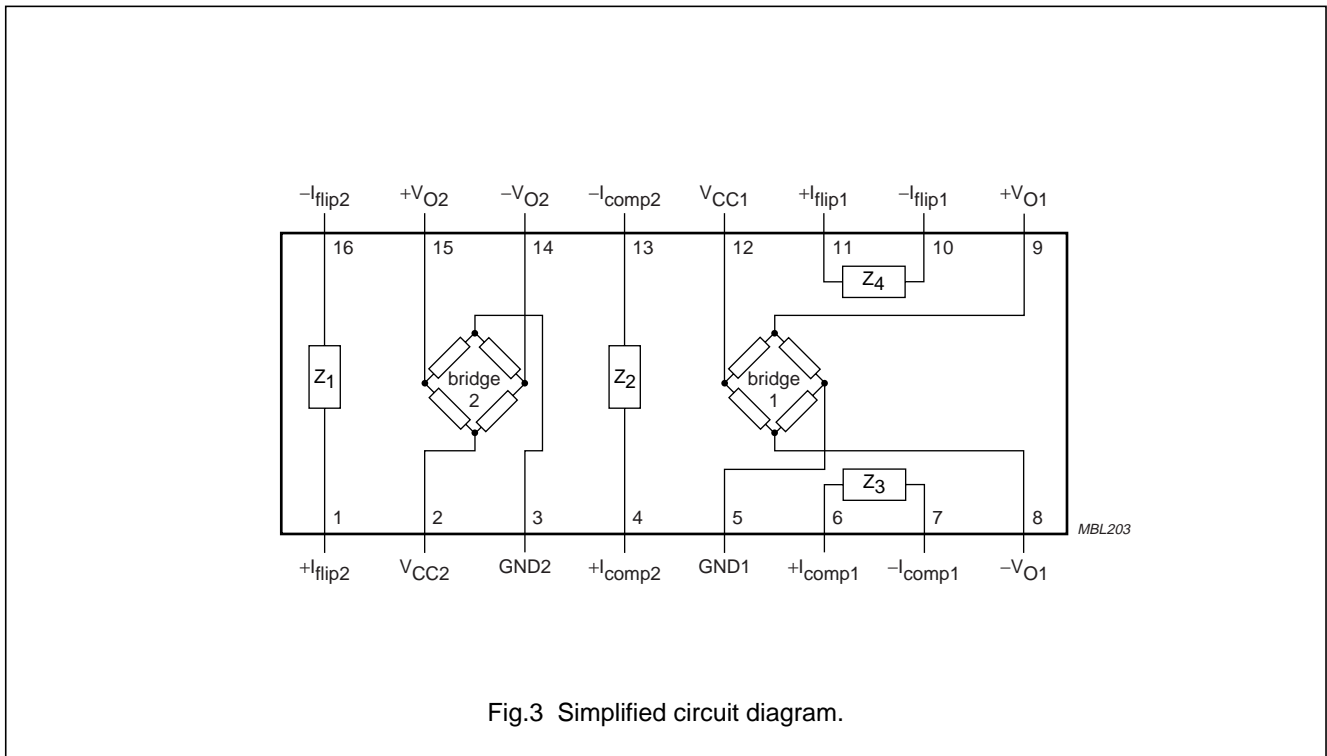
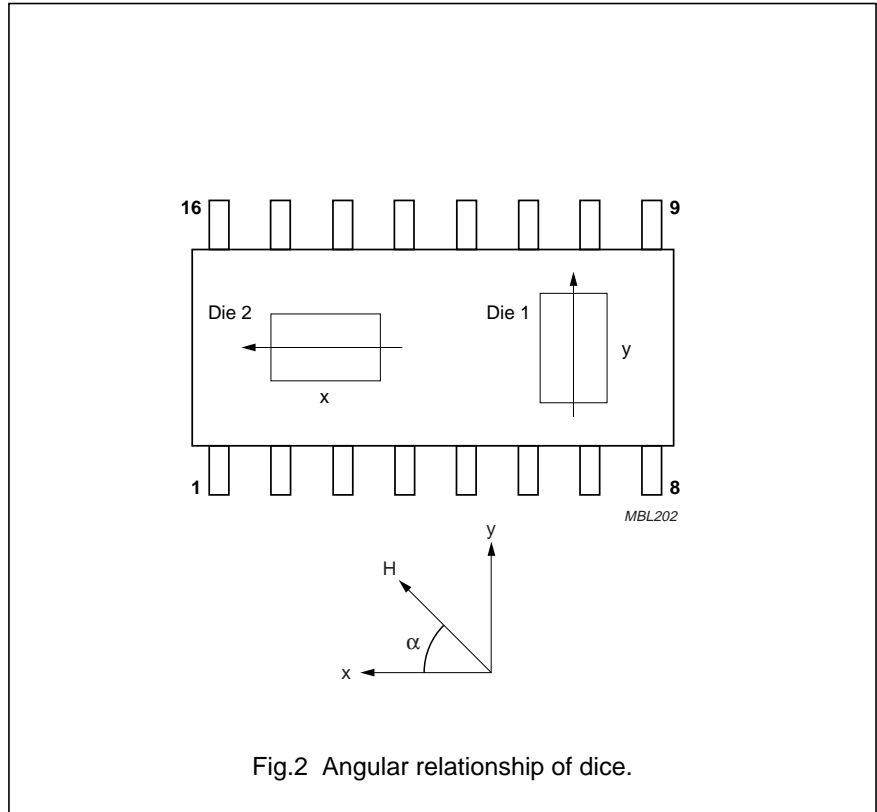

# Magnetic Field Sensor

KMZ52

## PACKAGE OUTLINE

SO16: plastic small outline package; 16 leads; body width 3.9 mm

SOT109-1

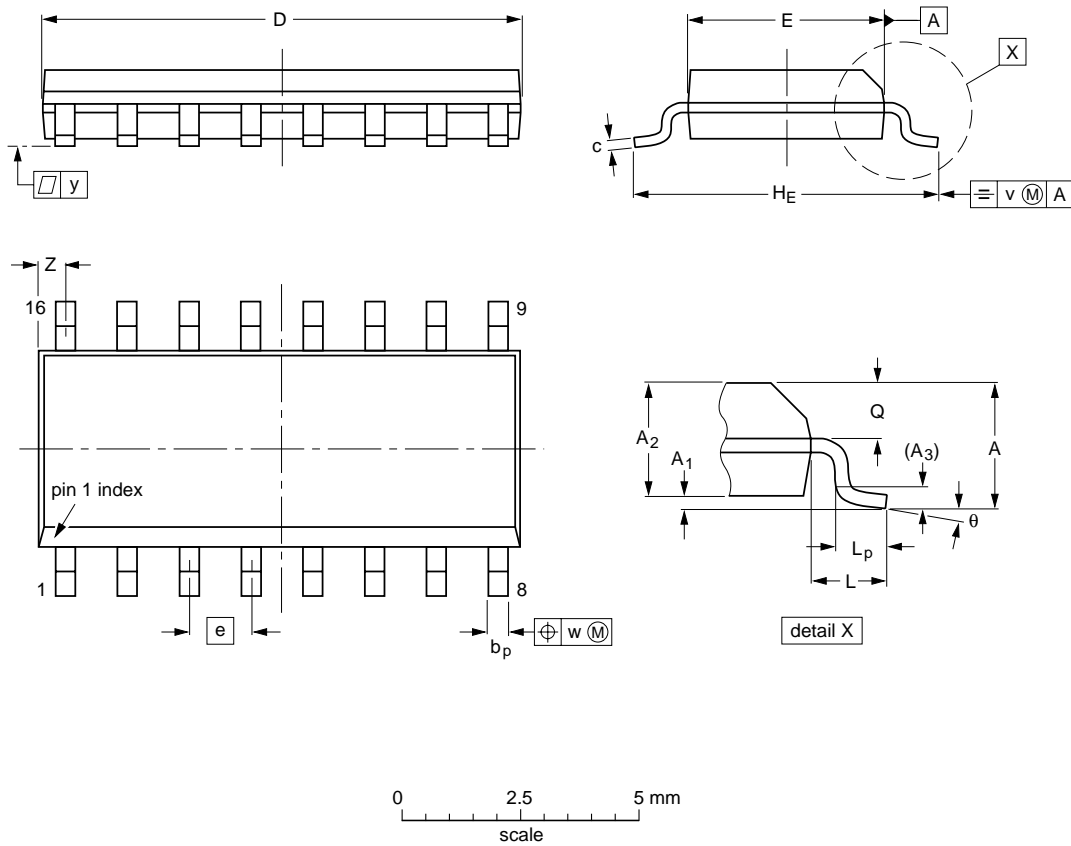

**DIMENSIONS (inch dimensions are derived from the original mm dimensions)**

UNIT	A max.	A <sub>1</sub>	A <sub>2</sub>	A <sub>3</sub>	b <sub>p</sub>	c	D <sup>(1)</sup>	E <sup>(1)</sup>	e	H <sub>E</sub>	L	L <sub>p</sub>	Q	v	w	y	Z <sup>(1)</sup>	θ
mm	1.75	0.25 0.10	1.45 1.25	0.25	0.49 0.36	0.25 0.19	10.0 9.8	4.0 3.8	1.27	6.2 5.8	1.05	1.0 0.4	0.7 0.6	0.25	0.25	0.1	0.7 0.3	8° 0°
inches	0.069	0.010 0.004	0.057 0.049	0.01	0.019 0.014	0.0100 0.0075	0.39 0.38	0.16 0.15	0.050	0.244 0.228	0.041	0.039 0.016	0.028 0.020	0.01	0.01	0.004	0.028 0.012	

**Note**

1. Plastic or metal protrusions of 0.15 mm maximum per side are not included.

OUTLINE VERSION	REFERENCES			EUROPEAN PROJECTION	ISSUE DATE
	IEC	JEDEC	EIAJ		
SOT109-1	076E07	MS-012			97-05-22- 99-12-27

## Magnetic Field Sensor

KMZ52

## DATA SHEET STATUS

DATA SHEET STATUS	PRODUCT STATUS	DEFINITIONS <sup>(1)</sup>
Objective specification	Development	This data sheet contains the design target or goal specifications for product development. Specification may change in any manner without notice.
Preliminary specification	Qualification	This data sheet contains preliminary data, and supplementary data will be published at a later date. Philips Semiconductors reserves the right to make changes at any time without notice in order to improve design and supply the best possible product.
Product specification	Production	This data sheet contains final specifications. Philips Semiconductors reserves the right to make changes at any time without notice in order to improve design and supply the best possible product.

## Note

1. Please consult the most recently issued data sheet before initiating or completing a design.

## DEFINITIONS

**Short-form specification** — The data in a short-form specification is extracted from a full data sheet with the same type number and title. For detailed information see the relevant data sheet or data handbook.

**Limiting values definition** — Limiting values given are in accordance with the Absolute Maximum Rating System (IEC 60134). Stress above one or more of the limiting values may cause permanent damage to the device. These are stress ratings only and operation of the device at these or at any other conditions above those given in the Characteristics sections of the specification is not implied. Exposure to limiting values for extended periods may affect device reliability.

**Application information** — Applications that are described herein for any of these products are for illustrative purposes only. Philips Semiconductors make no representation or warranty that such applications will be suitable for the specified use without further testing or modification.

## DISCLAIMERS

**Life support applications** — These products are not designed for use in life support appliances, devices, or systems where malfunction of these products can reasonably be expected to result in personal injury. Philips Semiconductors customers using or selling these products for use in such applications do so at their own risk and agree to fully indemnify Philips Semiconductors for any damages resulting from such application.

**Right to make changes** — Philips Semiconductors reserves the right to make changes, without notice, in the products, including circuits, standard cells, and/or software, described or contained herein in order to improve design and/or performance. Philips Semiconductors assumes no responsibility or liability for the use of any of these products, conveys no licence or title under any patent, copyright, or mask work right to these products, and makes no representations or warranties that these products are free from patent, copyright, or mask work right infringement, unless otherwise specified.



# Magnetic Field Sensor

KMZ52

---

## NOTES

# Magnetic Field Sensor

KMZ52

---

## NOTES

Magnetic Field Sensor

KMZ52

---

**NOTES**

# Philips Semiconductors – a worldwide company

**Argentina:** see South America

**Australia:** 3 Figtree Drive, HOMEBUSH, NSW 2140,  
Tel. +61 2 9704 8141, Fax. +61 2 9704 8139

**Austria:** Computerstr. 6, A-1101 WIEN, P.O. Box 213,  
Tel. +43 1 60 101 1248, Fax. +43 1 60 101 1210

**Belarus:** Hotel Minsk Business Center, Bld. 3, r. 1211, Volodarski Str. 6,  
220050 MINSK, Tel. +375 172 20 0733, Fax. +375 172 20 0773

**Belgium:** see The Netherlands

**Brazil:** see South America

**Bulgaria:** Philips Bulgaria Ltd., Energoproject, 15th floor,  
51 James Bourchier Blvd., 1407 SOFIA,  
Tel. +359 2 68 9211, Fax. +359 2 68 9102

**Canada:** PHILIPS SEMICONDUCTORS/COMPONENTS,  
Tel. +1 800 234 7381, Fax. +1 800 943 0087

**China/Hong Kong:** 501 Hong Kong Industrial Technology Centre,  
72 Tat Chee Avenue, Kowloon Tong, HONG KONG,  
Tel. +852 2319 7888, Fax. +852 2319 7700

**Colombia:** see South America

**Czech Republic:** see Austria

**Denmark:** Sydhavnsgade 23, 1780 COPENHAGEN V,  
Tel. +45 33 29 3333, Fax. +45 33 29 3905

**Finland:** Sinikalliontie 3, FIN-02630 ESPOO,  
Tel. +358 9 615 800, Fax. +358 9 6158 0920

**France:** 51 Rue Carnot, BP317, 92156 SURESNES Cedex,  
Tel. +33 1 4099 6161, Fax. +33 1 4099 6427

**Germany:** Hammerbrookstraße 69, D-20097 HAMBURG,  
Tel. +49 40 2353 60, Fax. +49 40 2353 6300

**Hungary:** see Austria

**India:** Philips INDIA Ltd, Band Box Building, 2nd floor,  
254-D, Dr. Annie Besant Road, Worli, MUMBAI 400 025,  
Tel. +91 22 493 8541, Fax. +91 22 493 0966

**Indonesia:** PT Philips Development Corporation, Semiconductors Division,  
Gedung Philips, Jl. Buncit Raya Kav.99-100, JAKARTA 12510,  
Tel. +62 21 794 0040 ext. 2501, Fax. +62 21 794 0080

**Ireland:** Newstead, Clonskeagh, DUBLIN 14,  
Tel. +353 1 7640 000, Fax. +353 1 7640 200

**Israel:** RAPAC Electronics, 7 Kehilat Saloniki St, PO Box 18053,  
TEL AVIV 61180, Tel. +972 3 645 0444, Fax. +972 3 649 1007

**Italy:** PHILIPS SEMICONDUCTORS, Via Casati, 23 - 20052 MONZA (MI),  
Tel. +39 039 203 6838, Fax +39 039 203 6800

**Japan:** Philips Bldg 13-37, Kohnan 2-chome, Minato-ku,  
TOKYO 108-8507, Tel. +81 3 3740 5130, Fax. +81 3 3740 5057

**Korea:** Philips House, 260-199 Itaewon-dong, Yongsan-ku, SEOUL,  
Tel. +82 2 709 1412, Fax. +82 2 709 1415

**Malaysia:** No. 76 Jalan Universiti, 46200 PETALING JAYA, SELANGOR,  
Tel. +60 3 750 5214, Fax. +60 3 757 4880

**Mexico:** 5900 Gateway East, Suite 200, EL PASO, TEXAS 79905,  
Tel. +9-5 800 234 7381, Fax +9-5 800 943 0087

**Middle East:** see Italy

**Netherlands:** Postbus 90050, 5600 PB EINDHOVEN, Bldg. VB,  
Tel. +31 40 27 82785, Fax. +31 40 27 88399

**New Zealand:** 2 Wagener Place, C.P.O. Box 1041, AUCKLAND,  
Tel. +64 9 849 4160, Fax. +64 9 849 7811

**Norway:** Box 1, Manglerud 0612, OSLO,  
Tel. +47 22 74 8000, Fax. +47 22 74 8341

**Pakistan:** see Singapore

**Philippines:** Philips Semiconductors Philippines Inc.,  
106 Valero St. Salcedo Village, P.O. Box 2108 MCC, MAKATI,  
Metro MANILA, Tel. +63 2 816 6380, Fax. +63 2 817 3474

**Poland:** Al.Jerozolimskie 195 B, 02-222 WARSAW,  
Tel. +48 22 5710 000, Fax. +48 22 5710 001

**Portugal:** see Spain

**Romania:** see Italy

**Russia:** Philips Russia, Ul. Usatcheva 35A, 119048 MOSCOW,  
Tel. +7 095 755 6918, Fax. +7 095 755 6919

**Singapore:** Lorong 1, Toa Payoh, SINGAPORE 319762,  
Tel. +65 350 2538, Fax. +65 251 6500

**Slovakia:** see Austria

**Slovenia:** see Italy

**South Africa:** S.A. PHILIPS Pty Ltd., 195-215 Main Road Martindale,  
2092 JOHANNESBURG, P.O. Box 58088 Newville 2114,  
Tel. +27 11 471 5401, Fax. +27 11 471 5398

**South America:** Al. Vicente Pinzon, 173, 6th floor,  
04547-130 SÃO PAULO, SP, Brazil,  
Tel. +55 11 821 2333, Fax. +55 11 821 2382

**Spain:** Balmes 22, 08007 BARCELONA,  
Tel. +34 93 301 6312, Fax. +34 93 301 4107

**Sweden:** Kottbygatan 7, Akalla, S-16485 STOCKHOLM,  
Tel. +46 8 5985 2000, Fax. +46 8 5985 2745

**Switzerland:** Allmendstrasse 140, CH-8027 ZÜRICH,  
Tel. +41 1 488 2741 Fax. +41 1 488 3263

**Taiwan:** Philips Semiconductors, 6F, No. 96, Chien Kuo N. Rd., Sec. 1,  
TAIPEI, Taiwan Tel. +886 2 2134 2886, Fax. +886 2 2134 2874

**Thailand:** PHILIPS ELECTRONICS (THAILAND) Ltd.,  
209/2 Sanpavuth-Bangna Road Prakanong, BANGKOK 10260,  
Tel. +66 2 745 4090, Fax. +66 2 398 0793

**Turkey:** Yukari Dudullu, Org. San. Blg., 2.Cad. Nr. 28 81260 Umraniye,  
ISTANBUL, Tel. +90 216 522 1500, Fax. +90 216 522 1813

**Ukraine:** PHILIPS UKRAINE, 4 Patrice Lumumba str., Building B, Floor 7,  
252042 KIEV, Tel. +380 44 264 2776, Fax. +380 44 268 0461

**United Kingdom:** Philips Semiconductors Ltd., 276 Bath Road, Hayes,  
MIDDLESEX UB3 5BX, Tel. +44 208 730 5000, Fax. +44 208 754 8421

**United States:** 811 East Arques Avenue, SUNNYVALE, CA 94088-3409,  
Tel. +1 800 234 7381, Fax. +1 800 943 0087

**Uruguay:** see South America

**Vietnam:** see Singapore

**Yugoslavia:** PHILIPS, Trg N. Pasica 5/v, 11000 BEOGRAD,  
Tel. +381 11 3341 299, Fax.+381 11 3342 553

**For all other countries apply to:** Philips Semiconductors,  
International Marketing & Sales Communications, Building BE-p, P.O. Box 218,  
5600 MD EINDHOVEN, The Netherlands, Fax. +31 40 27 24825

**Internet:** <http://www.semiconductors.philips.com>

© Philips Electronics N.V. 2000

SCA 69

All rights are reserved. Reproduction in whole or in part is prohibited without the prior written consent of the copyright owner.

The information presented in this document does not form part of any quotation or contract, is believed to be accurate and reliable and may be changed without notice. No liability will be accepted by the publisher for any consequence of its use. Publication thereof does not convey nor imply any license under patent- or other industrial or intellectual property rights.

Printed in The Netherlands

613520/01/pp12

Date of release: 2000 Jun 09

Document order number: 9397 750 07049

*Let's make things better.*

**Philips**  
Semiconductors



**PHILIPS**