



No. 3968

**LA4589W**

**1.5 V Stereo Headphone Preamplicifier  
and Power Amplifier**

**OVERVIEW**

The LA4589W is a 1.5 V stereo headphone preamplifier and power amplifier IC that provides all the functions of a complete playback system in a single chip, making it ideal for battery-powered, portable cassette players.

The LA4589W incorporates a metal/normal-tape equalization preamplifier, a power amplifier dual power supply ripple filters, a reference voltage amplifier that enables small-value (under 1  $\mu$ F) virtual-earth capacitors to be used, and a system controller.

The LA4589W features single-pin control bass boost and forward/reverse playback, an automatic music search (AMS) function, inputs for an auto-reverse tape mechanism, a power amplifier mute function a power switch, and selectable, single or dual ripple filter operation.

The LA4589W operates from a 0.95 to 2.2 V supply and is available in 48-pin SQFPs.

**FEATURES**

- Single-pin control bass boost
- Automatic music search (AMS)
- Preamplifier inputs for auto-reverse tape mechanism
- Single-pin control forward/reverse playback selection
- Two, on-chip, ripple filters
- Selectable, single or dual ripple filter operation
- Metal- and normal-tape modes
- Power amplifier mute function
- On-chip reference voltage amplifier
- No power amplifier output capacitors required.
- 73 dB (typ) preamplifier open-loop voltage gain
- 21 mW (typ) output power with bass boost
- Built-in noise reduction capacitors
- 0.95 to 2.2 V supply
- 48-pin SQFP

**PINOUT**

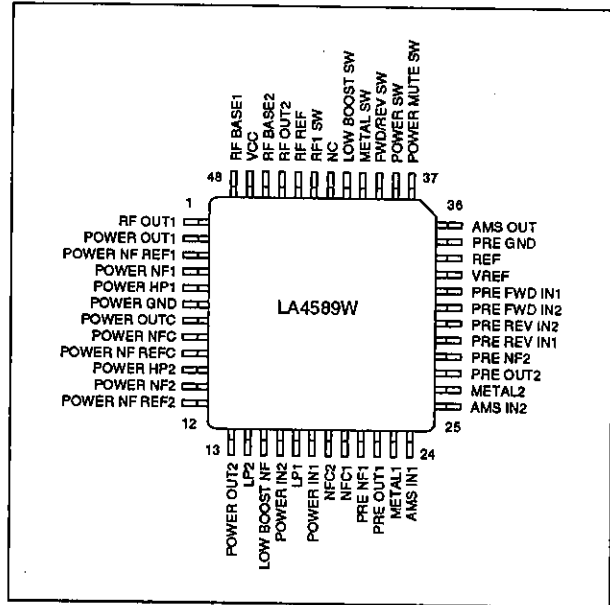

**PACKAGE DIMENSIONS**

Unit: mm

3163-SQFP48

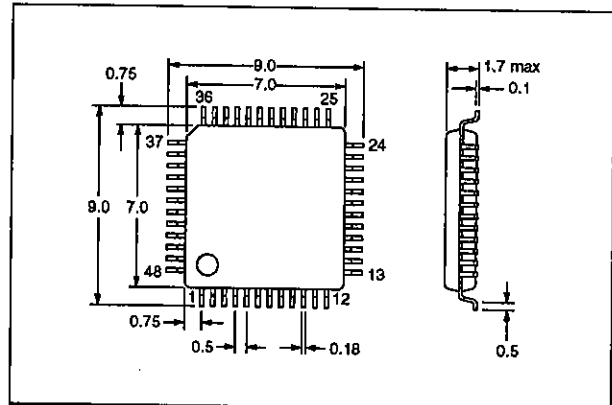

**BLOCK DIAGRAM**

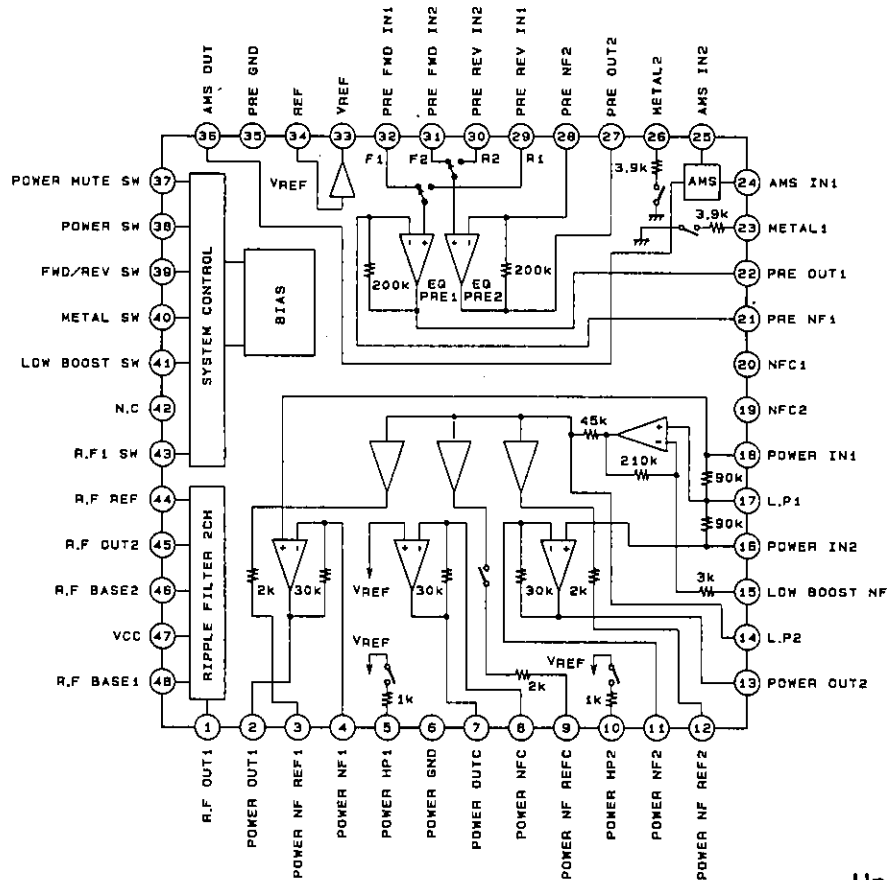

Unit (resistance:  $\Omega$ )

**PIN DESCRIPTION**

Number	Name	Equivalent circuit	Description
1	RFOUT1		Ripple filter outputs. Nominal voltage is 1.13 V.
45	RFOUT2		
2	POUT1		Power amplifier output 1. Nominal voltage is 0.6 V.
7	POUTC		Power amplifier common output. Nominal voltage is 0.6 V.
13	POUT2		Power amplifier output 2. Nominal voltage is 0.6 V.
3	PNFREF1		Power amplifier output 1 negative feedback reference voltage. Nominal voltage is 0.75 V.
9	PNFREFC		Power amplifier common output negative feedback reference voltage. Nominal voltage is 0.75 V.
12	PNFREF2		Power amplifier output 2 negative feedback reference voltage. Nominal voltage is 0.75 V.

LA4589W

Number	Name	Equivalent circuit	Description
4	PNF1		Power amplifier output 1 negative feedback network connection. Nominal voltage is 0.75 V.
8	PNFC		Power amplifier common output negative feedback network connection. Nominal voltage is 0.75 V.
11	PNF2		Power amplifier output 2 negative feedback network connection. Nominal voltage is 0.75 V.
5	PHP1		Power amplifier highpass filter outputs for bass boost. Nominal voltage is 0.75 V.
10	PHP2		
6	PGND		Power amplifier ground
14	LP2		Bass boost amplifier lowpass filter capacitor connection 2. Nominal voltage is 0.75 V.
15	LBNF		Bass boost amplifier negative feedback capacitor connection. Nominal voltage is 0.75 V.
16	PIN2		Power amplifier inputs. Nominal voltage is 0.75 V.
18	PIN1		
17	LP1		Bass boost amplifier lowpass filter capacitor connection 1. Nominal voltage is 0.75 V.

LA4589W

Number	Name	Equivalent circuit	Description
19	NFC2		Negative feedback capacitor connections. Nominal voltage is 0.75 V.
20	NFC1		
21	PRENF1		Preamplifier channel 1 negative feedback network connection. Nominal voltage is 0.75 V.
28	PRENF2		
22	PREOUT1		Preamplifier outputs. Nominal voltage is 0.45 V.
27	PREOUT2		
23	METAL1		Preamplifier channel 1 metal-tape mode connection. Nominal voltage is 0 V.
26	METAL2		
24	AMSIN1		Automatic music search inputs. Nominal voltage is 0.75 V.
25	AMSIN2		
29	PRER1		Preamplifier reverse playback inputs. Nominal voltage is 0.75 V.
30	PRER2		

LA4589W

Number	Name	Equivalent circuit	Description
31	PREF12		Preamplifier forward playback inputs. Nominal voltage is 0.75 V.
32	PREF11		
33	VREF		Reference voltage amplifier output. Nominal voltage is 0.75 V.
34	REF		
35	PREGND		Preamplifier ground
36	AMSOUT		Automatic music search output
37	PMUTESW		Power amplifier mute control input
41	LBSW		Bass boost control input
38	PSW		Power switch control input

# LA4589W

Number	Name	Equivalent circuit	Description
39	F/RSW		Forward/reverse playback control input
40	METALSW		Metal-tape mode control input
43	RF1SW		Ripple filter output 1 control input
42	NC		No connection
44	RFREF		Ripple filter capacitor connection. Nominal voltage is 1.13 V.
46	RFBASE2		Ripple filter external pnp-transistor 2 base connection. Nominal voltage is 0.5 V.
48	RFBASE1		Ripple filter external pnp-transistor 1 base connection. Nominal voltage is 0.5 V.
47	VCC		Supply voltage

**Note**

Nominal voltages are measured when  $V_{CC} = 1.2 \text{ V}$ .

## SPECIFICATIONS

### Absolute Maximum Ratings

Parameter	Symbol	Rating	Unit
Supply voltage	$V_{CC}$	3.0	V
Power dissipation	$P_D$	320	mW
Operating temperature range	$T_{opr}$	-10 to 60	°C
Storage temperature range	$T_{stg}$	-40 to 125	°C

### Recommended Operating Conditions

$T_a = 25 \text{ °C}$

Parameter	Symbol	Rating	Unit
Supply voltage	$V_{CC}$	1.5	V
Supply voltage range	$V_{CC}$	0.95 to 2.2	V

## Electrical Characteristics

## Preamplifier and power amplifier

 $V_{CC} = 1.2 \text{ V}$ ,  $T_a = 25 \text{ }^\circ\text{C}$ ,  $f = 1 \text{ kHz}$ ,  $0 \text{ dBm} = 0.775 \text{ V}$ ,  $R_L = 10 \text{ k}\Omega$  (preamplifier),  $R_L = 16 \text{ }\Omega$  (power amplifier)

Parameter	Symbol	Condition	Rating			Unit
			min	typ	max	
Quiescent supply current	$I_{CCQ}$	$R_g = 2.2 \text{ k}\Omega$ , $R_v = 0 \text{ }\Omega$	8	15	24	mA
		PSW is OFF.	–	0.1	5.0	$\mu\text{A}$
Closed-loop voltage gain	$V_{GT}$	$V_O = -20 \text{ dBm}$ , $R_v = 10 \text{ k}\Omega$	54	57	60	dB

## Preamplifier

 $V_{CC} = 1.2 \text{ V}$ ,  $T_a = 25 \text{ }^\circ\text{C}$ ,  $f = 1 \text{ kHz}$ ,  $0 \text{ dBm} = 0.775 \text{ V}$ ,  $R_L = 10 \text{ k}\Omega$  (preamplifier),  $R_L = 16 \text{ }\Omega$  (power amplifier)

Parameter	Symbol	Condition	Rating			Unit
			min	typ	max	
Open-loop voltage gain	$V_{GO}$	$V_O = -20 \text{ dBm}$	60	73	–	dB
Closed-loop voltage gain	$V_{GC}$	$V_O = -20 \text{ dBm}$	34.0	35.5	37.0	dB
		$V_O = -20 \text{ dBm}$ , $f = 10 \text{ kHz}$ , METALSW is ON.	25.5	28.0	30.5	
Maximum output voltage	$V_O \text{ max}$	THD = 1%	100	210	–	mV
Total harmonic distortion	THD	$V_G = 35.5 \text{ dB/NAB}$ , $V_O = 100 \text{ mV}$	–	0.1	0.5	%
Input noise voltage	$V_{NI}$	$R_g = 2.2 \text{ k}\Omega$ , 20 Hz to 20 kHz bandpass filter	–	1.3	3.0	$\mu\text{V}$
Crosstalk rejection between channel 1 and channel 2	CT	$R_g = 2.2 \text{ k}\Omega$ , $V_O = -20 \text{ dBm}$ , 1 kHz tuned filter	45	56	–	dB
Crosstalk rejection between forward and reverse tracks			65	78	–	
Supply voltage ripple rejection ratio	SVRR	$R_g = 2.2 \text{ k}\Omega$ , $V_i = -30 \text{ dBm}$ , $f_r = 100 \text{ Hz}$ , 100 Hz tuned filter	45	52	–	dB

## Power amplifier with bass boost

 $V_{CC} = 1.2 \text{ V}$ ,  $T_a = 25 \text{ }^\circ\text{C}$ ,  $f = 1 \text{ kHz}$ ,  $0 \text{ dBm} = 0.775 \text{ V}$ ,  $R_L = 10 \text{ k}\Omega$  (preamplifier),  $R_L = 16 \text{ }\Omega$  (power amplifier)

Parameter	Symbol	Condition	Rating			Unit
			min	typ	max	
Closed-loop voltage gain	$V_{GC}$	$V_O = -20 \text{ dBm}$	20.5	23.0	25.5	dB
		$V_O = -20 \text{ dBm}$ , LBSW is ON.	20.5	23.0	25.5	
		$V_O = -20 \text{ dBm}$ , $f = 10 \text{ kHz}$ , LBSW is ON.	24.5	27.5	30.5	
		$V_O = -20 \text{ dBm}$ , $f = 100 \text{ Hz}$ , LBSW is ON.	30	34	38	

**LA4589W**

Parameter	Symbol	Condition	Rating			Unit
			min	typ	max	
Output power	P <sub>O</sub>	THD = 10%	5	9	–	mW
		THD = 10%, f = 100 Hz. LBSW is ON.	13	21	–	
Total harmonic distortion	THD	P <sub>O</sub> = 1 mW	–	0.5	1.5	%
Crosstalk rejection between left and right channels	CT	V <sub>O</sub> = –20 dBm, R <sub>V</sub> = 0 Ω	38	43	–	dB
Output noise voltage	V <sub>NO</sub>	R <sub>V</sub> = 0 Ω, 20 Hz to 20 kHz bandpass filter	–	35	48	μV
Supply voltage ripple rejection ratio	SVRR	R <sub>V</sub> = 0 Ω, V <sub>r</sub> = –30 dBm, f <sub>r</sub> = 100 Hz, 100 Hz tuned filter	50	74	–	dB
Input impedance	R <sub>i</sub>		8	10	12	kΩ
Voltage gain differential	ΔVG		–	0	1.5	dB

**Ripple filter**

V<sub>CC</sub> = 1.0 V, T<sub>a</sub> = 25 °C, f = 1 kHz, 0 dBm = 0.775 V, R<sub>L</sub> = 10 kΩ (preamplifier), R<sub>L</sub> = 16 Ω (power amplifier)

Parameter	Symbol	Condition	Rating			Unit
			min	typ	max	
Output voltage	V <sub>RF</sub>	I <sub>RF</sub> = 25 mA	0.89	0.93	–	V
Supply voltage ripple rejection ratio	SVRR	f <sub>r</sub> = 100 Hz, V <sub>r</sub> = –30 dBm, I <sub>RF</sub> = 25 mA, output transistors with h <sub>FE</sub> ≥ 6 (2SB1295)	33	39	–	dB

**Automatic music search (AMS)**

V<sub>CC</sub> = 1.2 V, T<sub>a</sub> = 25 °C, f = 1 kHz, 0 dBm = 0.775 V, R<sub>L</sub> = 10 kΩ (preamplifier), R<sub>L</sub> = 16 Ω (power amplifier)

Parameter	Symbol	Condition	Rating			Unit
			min	typ	max	
AMS output voltage	V <sub>OAMS</sub>	V <sub>PREOUT1</sub> = V <sub>PREOUT2</sub> = 8 mV	470	570	670	mV



Measurement Circuit

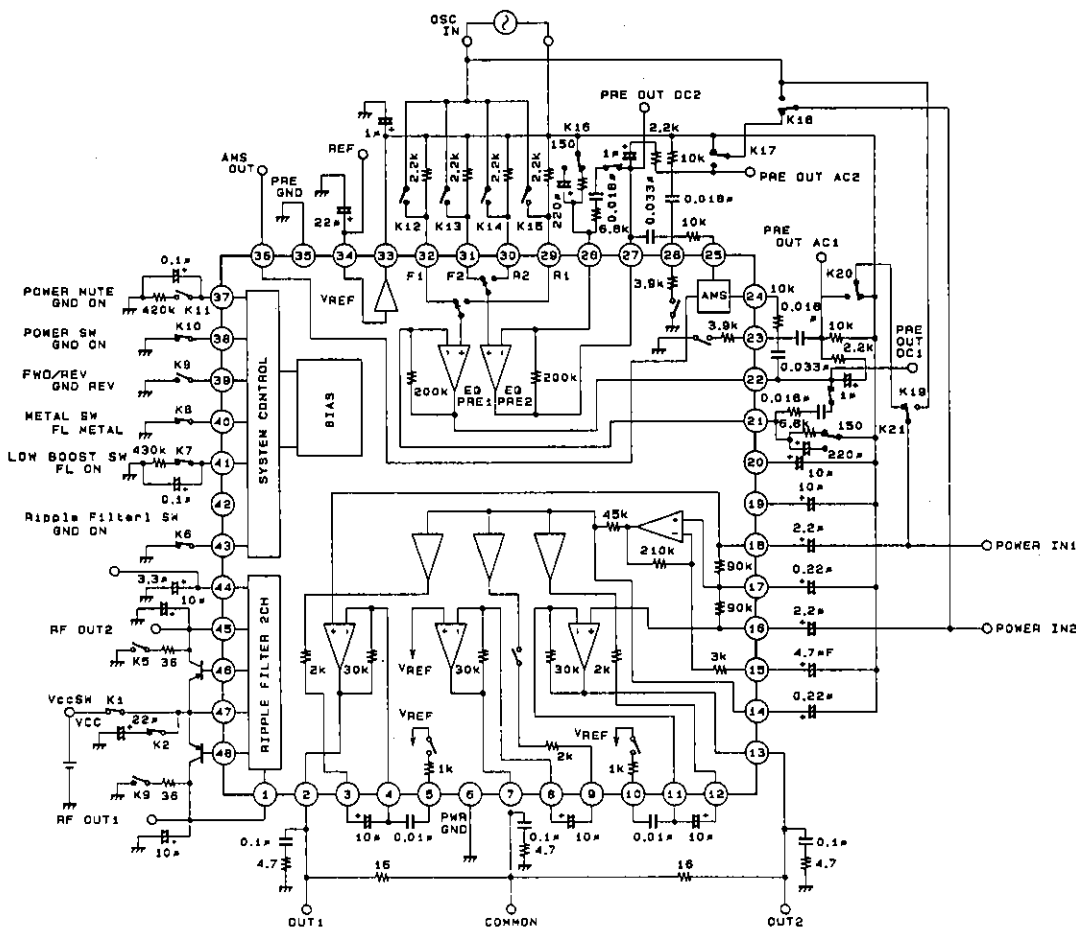

Typical Performance Characteristics

Unit (resistance: Ω, capacitance: F)

Maximum power dissipation vs. ambient temperature

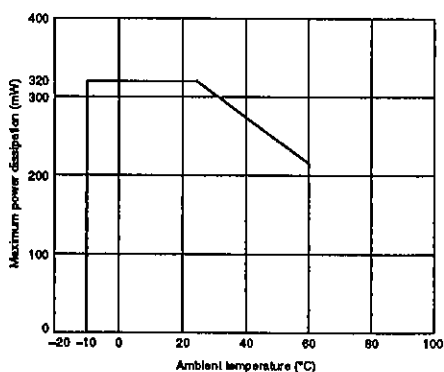

## FUNCTIONAL DESCRIPTION

### Preamplifier

The preamplifier incorporates equalization networks for normal- and metal-tape playback modes, and tape-direction switches for an auto-reverse cassette mechanism.

When METALSW is floating, metal-tape mode is selected. METAL1 and METAL2 are grounded internally through 3.9 k $\Omega$  resistors, adjusting the negative feedback network to provide metal-tape playback equalization.

When F/RSW is floating, forward playback mode is selected, and PREFI1 and PREFI2 are connected to the preamplifier inputs. When F/RSW is grounded, reverse playback mode is selected, and PRERI1 and PRERI2 are connected to the preamplifier inputs.

The automatic music search (AMS) circuit generates a signal that controls the cassette mechanism fast-forward and reverse functions in response to pauses between music tracks. The signal on AMSOUT is a pulse wave whose amplitude varies with the input signal levels on AMSIN1 and AMSIN2.

### Power Amplifier

The power amplifier incorporates an additional amplifier to provide bass boost and mute functions.

When LBSW is floating, the bass boost function is selected. PHP1 and PHP2 are connected to VREF through 1 k $\Omega$  internal resistors, adjusting the negative feedback network to provide highpass filtering.

When PMUTESW is grounded, the power amplifier mute function is selected.

### Ripple Filter

The ripple filters can be configured for either single or dual-filter operation. When RF1SW is grounded, the ripple filters are configured for dual-filter operation and RFOUT1 is active.

### External Components Required

Component	Recommended value	Description
C1	1.0 to 10 $\mu$ F	Reference voltage amplifier decoupling capacitor. Decreasing the capacitance reduces the supply voltage ripple rejection ratio.
C2, C10	-	Preamplifier equalization RC network capacitors.
C3, C9	0.47 to 3.3 $\mu$ F	Preamplifier output capacitors
C4, C8	-	AMS input highpass filter RC network capacitors
C5, C7	-	Metal-tape equalization RC network capacitors
C6	0.1 to 22 $\mu$ F	Reference voltage decoupling capacitor. Reduces high-band noise.
C11, C12	3.3 to 10 $\mu$ F	NFC decoupling capacitors. Decreasing the capacitance reduces the preamplifier low-band gain.
C13, C15	1.0 to 3.3 $\mu$ F	Power amplifier input capacitors
C14, C17	-	Low-boost lowpass filter and amplifier gain adjust capacitors
C16	1.0 to 4.7 $\mu$ F	Bass boost amplifier negative feedback capacitor. Decreasing the capacitance reduces the low-band gain.
C18, C23, C26	0.1 to 1.0 $\mu$ F	Power amplifier output oscillation-damping RC network capacitors
C19, C22, C25	3.3 to 10.0 $\mu$ F	Power amplifier negative feedback capacitors. Decreasing the capacitance reduces the low-band gain.
C20, C24	-	Power amplifier highpass filter high-band gain adjust capacitors (bass-boost only)
C21	100 to 2200 pF	Smoothing capacitor
C27, C29	4.7 to 10 $\mu$ F	Ripple filter output decoupling capacitors
C28	22 to 220 $\mu$ F	Power supply capacitor
C30	2.2 to 10.0 $\mu$ F	Ripple filter capacitor
C31, C32	0.047 to 0.22 $\mu$ F	Switching noise filter capacitors
R1, R10	-	Preamplifier gain adjust resistors

# LA4589W

Component	Recommended value	Description
R2, R9		Preamplifier equalization RC network resistors
R3, R8		Metal-tape preamplifier equalization RC network resistors
R4, R7	10 k $\Omega$ variable	Volume control resistors
R5, R6	-	Automatic music search (AMS) highpass filter and gain adjust resistors
R11, R12, R13	-	Power amplifier output oscillation-damping RC network resistors
R14, R15	100 to 430 k $\Omega$	Switching noise filter resistors

## TYPICAL APPLICATION

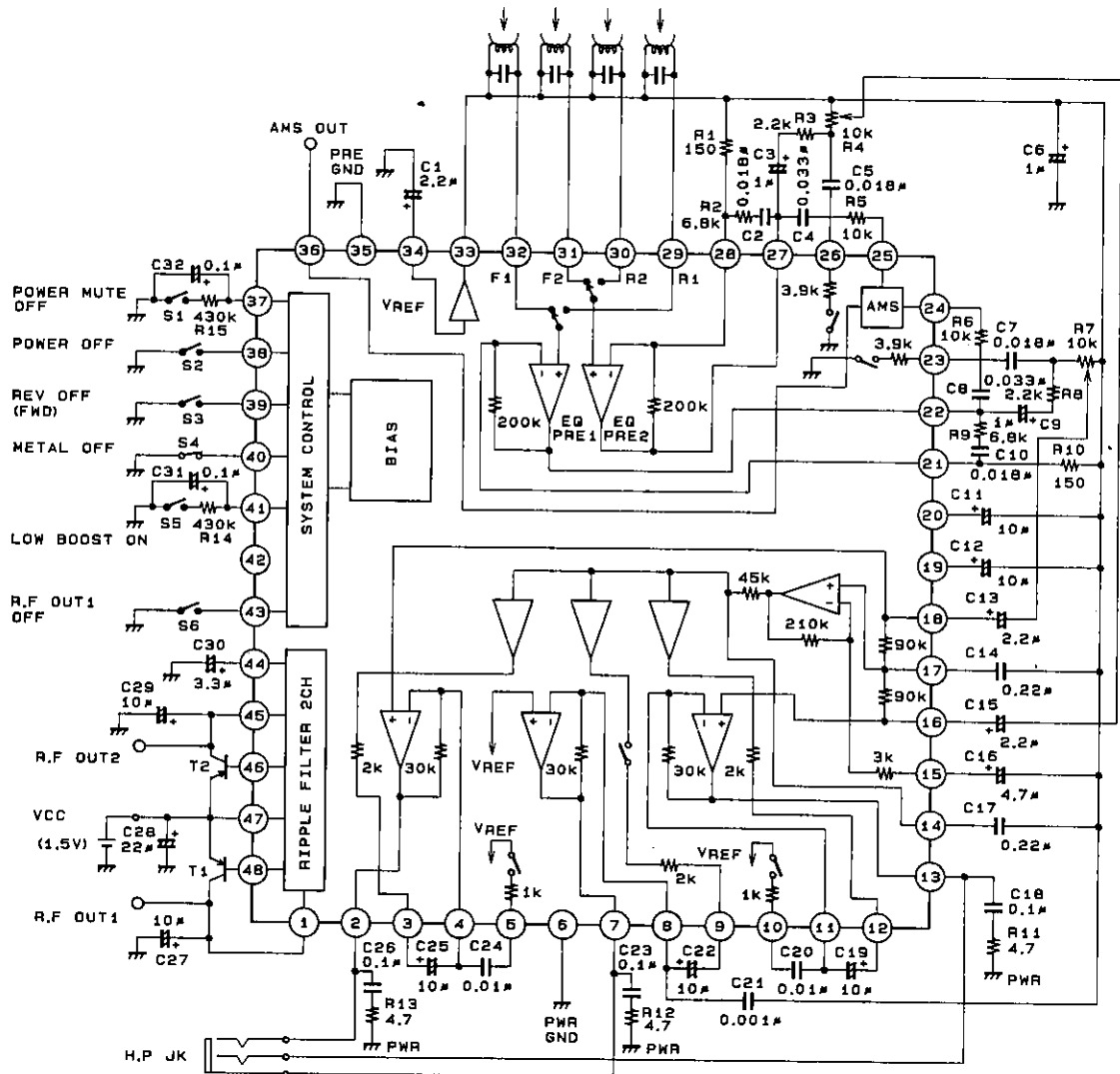

Unit (resistance:  $\Omega$ , capacitance: F)

- No products described or contained herein are intended for use in surgical implants, life-support systems, aerospace equipment, nuclear power control systems, vehicles, disaster/crime-prevention equipment and the like, the failure of which may directly or indirectly cause injury, death or property loss.
- Anyone purchasing any products described or contained herein for an above-mentioned use shall:
  - ① Accept full responsibility and indemnify and defend SANYO ELECTRIC CO., LTD., its affiliates, subsidiaries and distributors and all their officers and employees, jointly and severally, against any and all claims and litigation and all damages, cost and expenses associated with such use;
  - ② Not impose any responsibility for any fault or negligence which may be cited in any such claim or litigation on SANYO ELECTRIC CO., LTD., its affiliates, subsidiaries and distributors or any of their officers and employees jointly or severally.
- Information (including circuit diagrams and circuit parameters) herein is for example only; it is not guaranteed for volume production. SANYO believes information herein is accurate and reliable, but no guarantees are made or implied regarding its use or any infringements of intellectual property rights or other rights of third parties.