

Description

The SL1019P is a AM electronic tuner IC with high performance. It is greatly improved cross modulation characteristics.

Function

- RF wide-band AGC, Attenuator Driver, Local OSC with ALC, Local OSC Buffer, Mixer, IF Amp, IF AGC, Detector, Signal Meter.

Features

- Low noise.
- V_{CC} variation compensation.
- The local OSC buffer output facilitates designing of electronic tuner system, frequency display and etc.
- The narrow band signal meter output is usable as auto search stop signal.
- The excellent cross modulation characteristics prevent not only adjacent-channel interference but also interference caused by all channels with in broadcast band.
- The OSC with ALC improves tracking error.
- Double balanced differential MIX.
- Recommended supply voltage : $V_{CC} = 8V$
- Operating Supply Voltage range : $V_{CC} = 7.5V \sim 12V$

Application

- The AM car radios and the home receivers.

Ordering Information

Type NO.	Marking	Package Code
SL1019P	SL1019	DIP20

Outline Dimensions

unit : mm

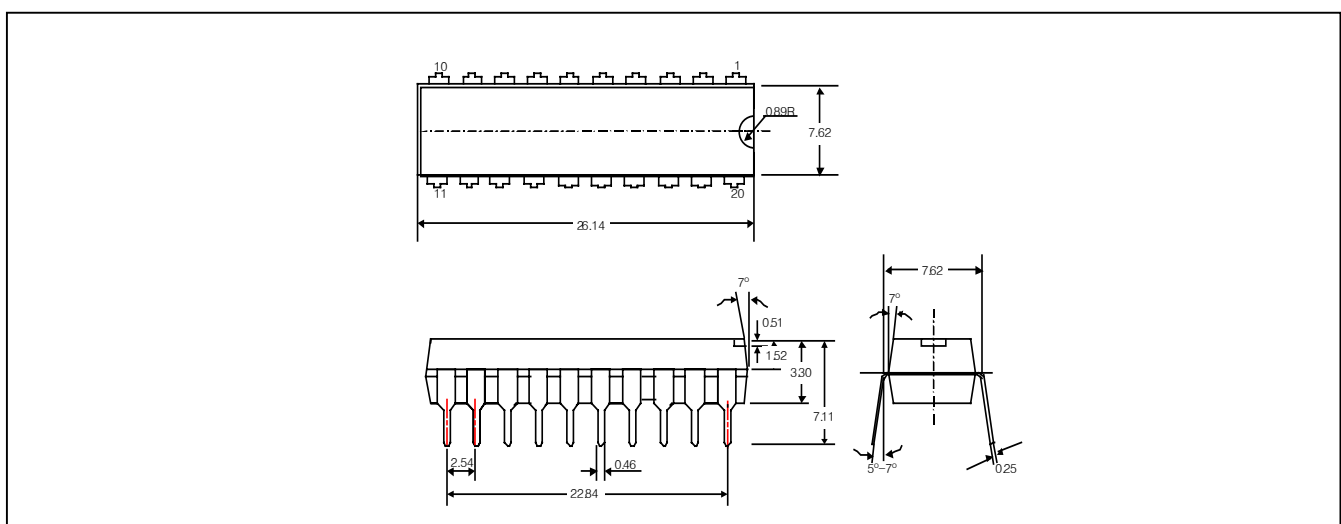

Absolute Maximum Ratings

(Ta = 25°C)

Characteristics	Symbol	Rating	Unit
Supply Voltage	V _{CC}	16	V
Supply Current	I _{CC}	41	mA
MIX Output and IF Amp Output Voltage	V _{OUT}	24	V
MIX Input and RF Amp 1 Input Voltage	V _{IN}	5.6	V
Local OSC Current	I _{OSC}	2	mA
Power Dissipation	P _D	730	mW
Operating Temperature	T _{opr}	- 20 ~ + 70	°C
Storage Temperature	T _{stg}	- 40 ~ + 125	°C

Block Diagram

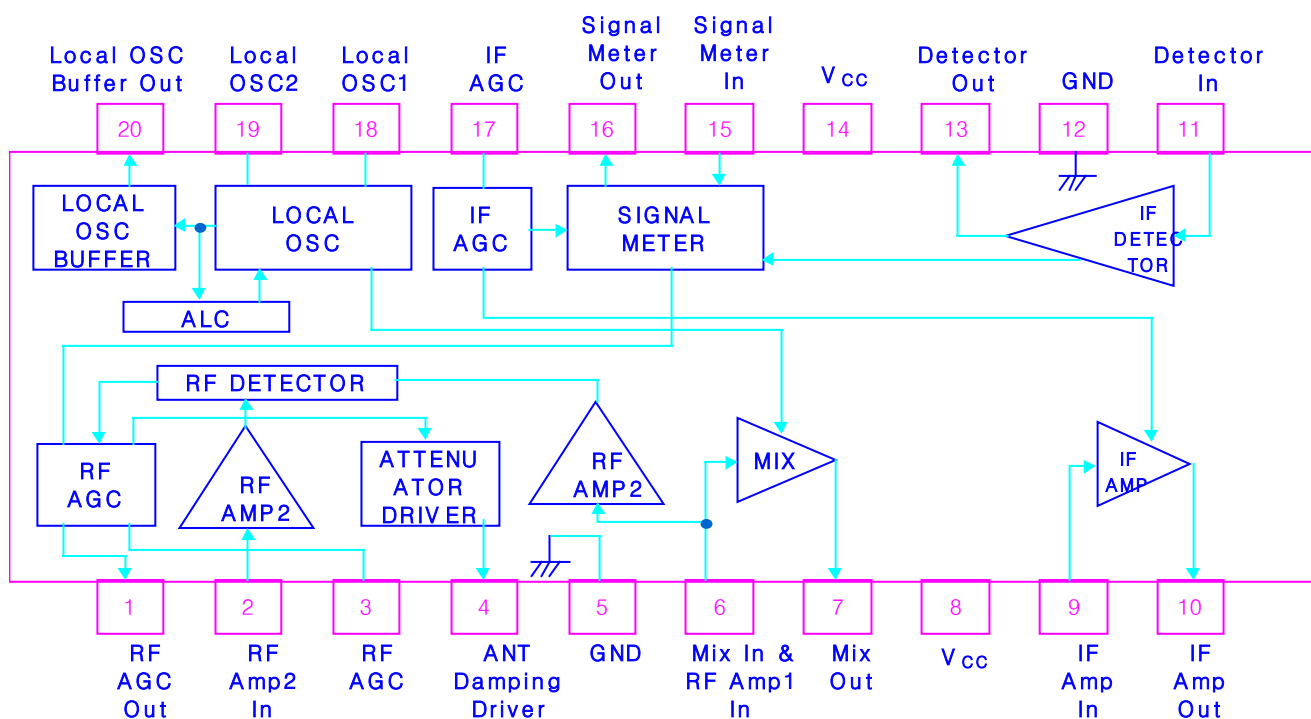

Electrical Characteristics(continued)

Characteristics	Symbol	Test Condition	Min.	Typ.	Max.	Unit
Input Voltage at Signal Meter Output 1V	V_{IN}	$V_{SM} = 1V$	18	24	30	dB_{μ}
Local OSC Buffer Output	$V_{OSC} (BUF)$	-	320	380	-	mVrms
Quieting sensitivity	QS	S/N = 20dB	-	25	-	dB_{μ}
Detection Output Variation	ΔV_{OD}	Input $74dB_{\mu} \rightarrow 130dB_{\mu}$	-	0.2	-	dB
Wide-Band AGC On State Input	WB_{AGC}	Interference 1.4MHz Non mod. Reception 1MHz quiescent. Input for ANT Damping ON.	-	82	-	dB_{μ}
Local OSC Variation within broadcast band	ΔV_{osc}	$V_{OSCL} - V_{OSCH}$	-	15	-	mVrms
Signal Meter Band	V_{SM-BW1}	$74dB_{\mu}$ input, frequency at which output is reduced to 1/2	-	± 1.5	-	KHz
	V_{SM-BW2}	$74dB_{\mu}$ input, frequency at which output is reduced to 1/10	-	$4.5/+7$	-	KHz
Selectivity	SEL	30% mod $\pm 10kHz$, WB_{AGC} : "OFF"	-	43	-	dB
IF Interference	IF.I.	$f_r = 600kHz$, WB_{AGC} : "OFF"	-	77.5	-	dB
Image Frequency Interference	IM.I.	$f_r = 1400kHz$, WB_{AGC} : "OFF"	-	52	-	dB

Information in using IC

1. Use the bias condition in "RF $V_{CC} \leq$ IF V_{CC} "
2. Avoid coupling between the antenna tuning circuit and the local OSC.
3. Connect detection capacitor (C_{15}) between pin13(output) and pin14(V_{CC}) so that no leakage of the IF signal to the GND line occurs. If the capacitor C_{15} is connected to GND, the S/N ratio and the usable sensitivity may get worse. Radiation from C_{15} may cause harmonics in the IF signal to return to the RF stage, and the result may lead to more tweet interference. So, connect C_{15} as close to pin 13,14 as possible. Consider the direction of the capacitor and separate it from the ANT circuit.
4. Use a semi-fixed resistor for R_9 with V_{SM} considered.
5. Consider the following conditions when designing the coils. The table is the input level at each pin at which the detection output at $f_m = 400Hz$ 30% mod becomes -25 dBm.

Information in using IC(Continued)

Table.

Stage	ANT	MIX	IF	DET
Input level (dBμ)	16	28	45	61

* Each stage is applied input as shown below.

ANT Stage

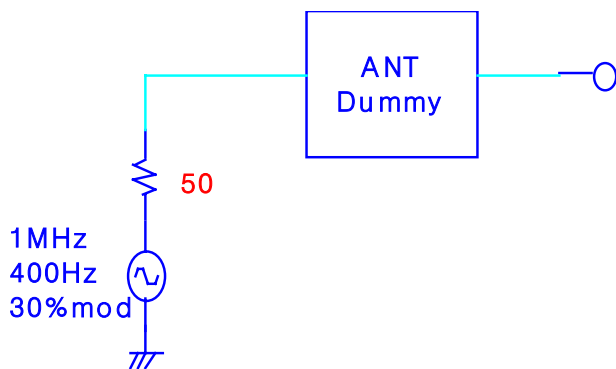

MIX Stage

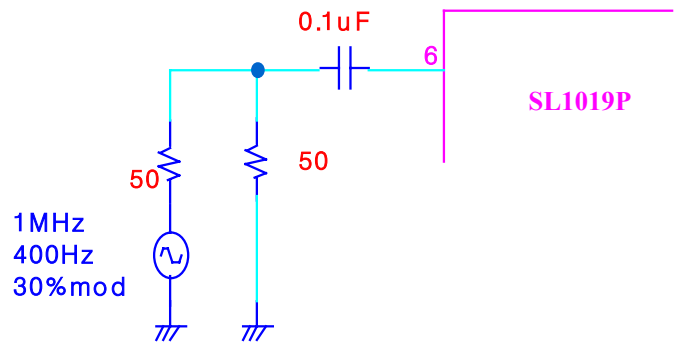

IF Stage

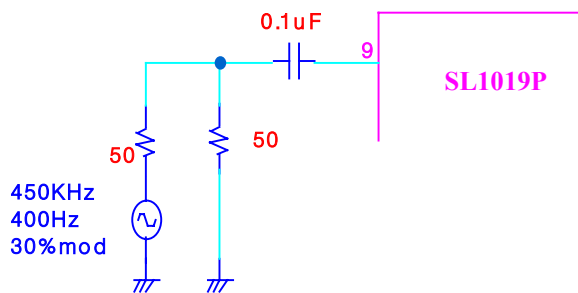

Det Stage

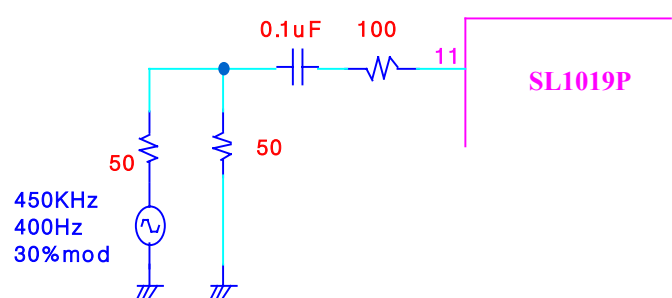

6. To make the ANT damping constant within the receiving band, change the application circuit as shown below.

※Reference Circuit

※Changing Circuit

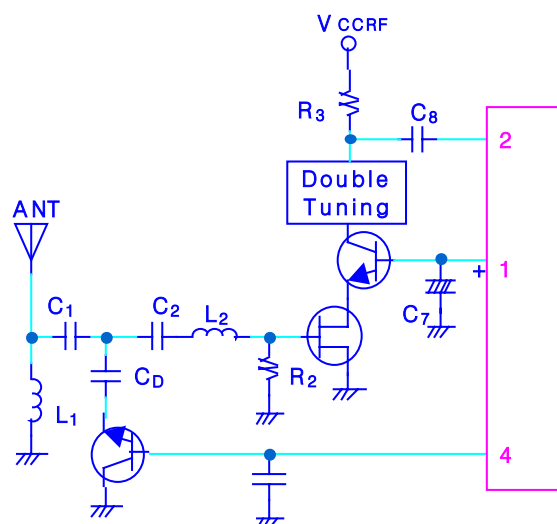
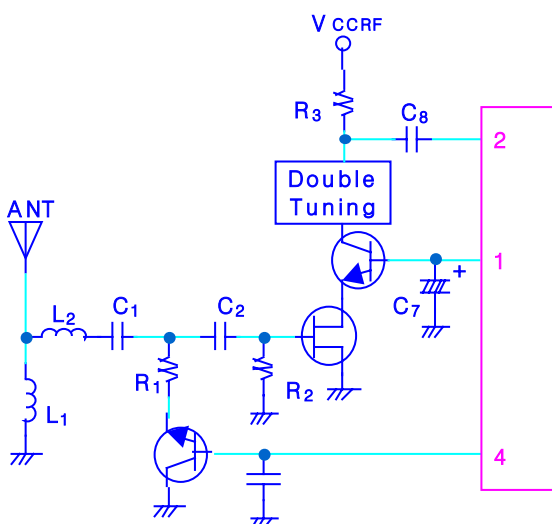

Information in using IC(Continued)

C_D is 2000pF to 3000pF or thereabouts

L_2 Damping(600kHz ~ 1400kHz) } Reference Circuit: -15dB
} Changing Circuit : -4dB

7. The L_2 is used to remove the SW band.

If the RF stage is double-tuned, the difference in sensitivity within the RF band almost disappears. thereby leading to worse spurious characteristic.

8. The SL1019P contains 2-channel wide-band AGC.

The pin 6 detects and undesired signal within the RF band and wide-band AGC is applied. This detection sensitivity is determined inside the IC. The pin 2 detects and undesired signal outside the RF band. This detection sensitivity is determined by R_3 . When 1mVrms($f=1\text{MHz}$) signal is applied to pin 2, AGC operates.

9. In the AGC circuit of the test circuit the presence of an undesired signal of high strength within the receiving band may cause the desired signal to be suppressed when the desired signal is low or medium in strength. Shown below is the circuit configuration where the necessary measures are taken against this suppression.

10. The circuit shown below is available to stabilize the transient response of the signal meter output at the search stop mode.

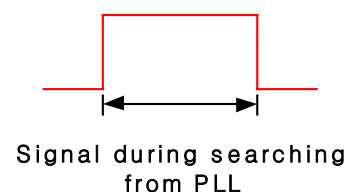
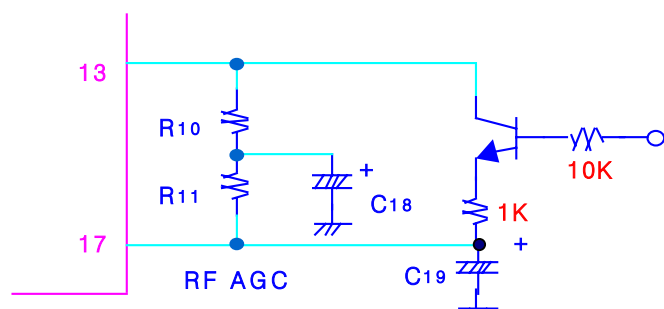
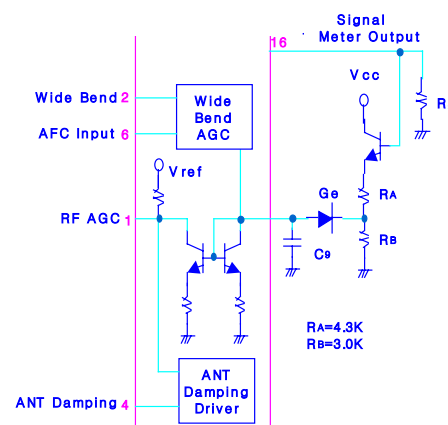

11. When using MW, no additional resistor is required

But when using LW(approximately 50°C or greater), additionally connect a resistor of 27KΩ across pins 18 and 19 against increase in local OSC level.

12. For improvement in image frequency interference change the RF double tuning coil as follows, and the image frequency interference becomes 63dB at $f_r = 1400\text{KHz}$ (Q point of the tuning circuit must not be decreased with tuning resistor 100KΩ)

Information in using IC (Continued)

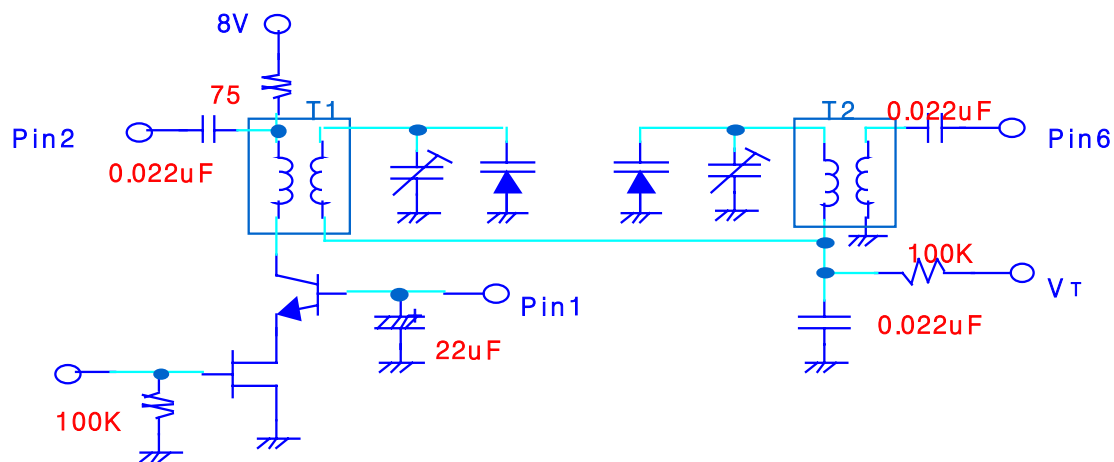

13. Shown below is cross modulation characteristic.

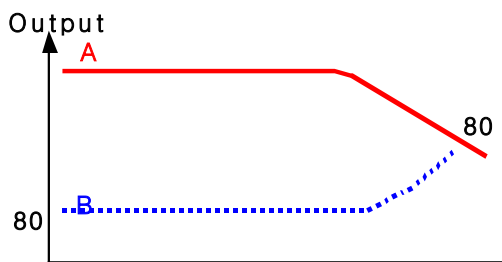

Testing Method

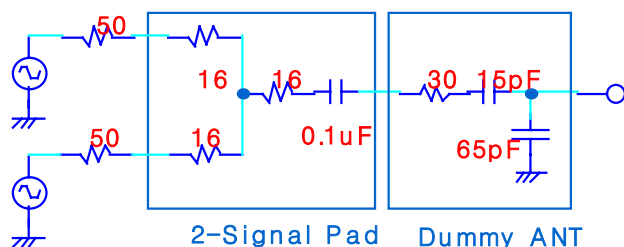

A: Desired signal 83dB μ 400Hz 30% mod. The strength of an undesired signal (non mod) causes the desired signal to be suppressed.

B: Desired signal 80dB μ non-mod. The strength of an undesired signal (40Hz 80% mod) causes interference to occur.

COIL DATA (for test circuit)

1. RF double Tuning

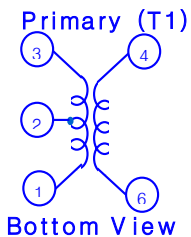

Item	L(μH)	Turns		
Pin No.	1 - 3	1 - 2	2 - 3	4 - 6
Value	224	2	82	37

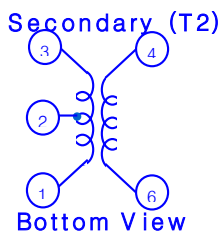

Item	L(μH)	Turns		
Pin No.	1 - 3	1 - 2	2 - 3	4 - 6
Value	224	2	82	15

2. IFT(1) Coil (T3)

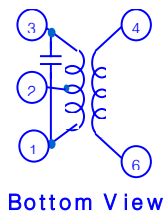

Item	C ₀ (pF)	f(KHz)	Q ₀	Turns		
Pin No.	1 - 3	-	1 - 3	1 - 2	2 - 3	4 - 6
Value	180	450	115	69	77	14

High Selectivity Type

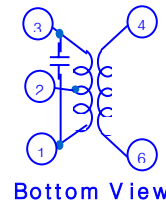

Item	C ₀ (pF)	f(KHz)	Q ₀	Turns		
Pin No.	1 - 3	-	1 - 3	1 - 2	2 - 3	4 - 6
Value	180	450	45	49	103	27

3. IFT(2) Coil (T4)

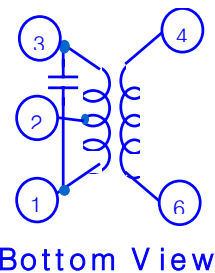

Item	C ₀ (pF)	f(KHz)	Q ₀	Turns		
Pin No.	1 - 3	-	1 - 3	1 - 2	2 - 3	4 - 6
Value	180	455	110	115	37	6

4. OSC Coil (T5)

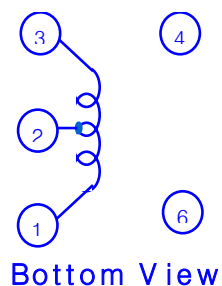

Item	L(μH)	f(MHz)	
Pin No.	1 - 3	1 - 2	2 - 3
Value	118	29	29

Typical Performance Characteristics

