

FREQUENCY RANGE	10 MHz to 240 MHz
FREQUENCY ACCURACY @ + 25 °C	± 0.0015% (± 15 PF
FREQUENCY STABILITY Vs. TEMPERATURE	See Options Below
OPERATING TEMPERATURE RANGE	See Options Below
INPUT VOLTAGE (See Note Below)	- 5.2 VDC ± 10%
INPUT CURRENT @ - 5.2 VDC	50 mA Max.
OUTPUT	10K, 10KH Compatibl
LOAD	100 Ω to - 2.0 VDC
SYMMETRY	60/40% @ 50% Leve
RISE & FALL TIMES (10% to 90% Level)	2 nS Max.
START-UP TIME	15 mS Max.

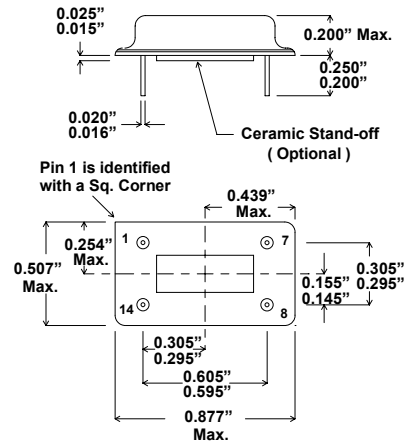

FREQUENCY STABILITY Vs. VOLTAGE	± 0.0002% (± 2 PPM) Max. (for 10% change in Voltage)
AGING @ +25 °C	± 0.0005% (± 5 PPM) / year Max.
PACKAGE, SEAL & LEAD FINISH	Conforms with the Requirements of MIL-PRF-55310

Pin Connections	
14	GND/CASE
7	-5.2 VDC
8	OUTPUT
1	N/C
All Others	MISSING

NOTE: For PECL applications, Xsis 300 Series ECL oscillators can be operated with +5 VDC ± 10% on Pin 14 and power supply return on Pin 7. The output logic levels will still be referenced to +5 VDC and the case will be at +5 VDC, however, 0.8 V peak to peak output signal can be AC or DC coupled as necessary.

Contact Xsis Engineering for special requirements such as, Output Symmetry, Start-up Time, Frequency Accuracy, Complementary Outputs, Multiple Outputs, etc.

ORDERING INFORMATION (Select from options below) :

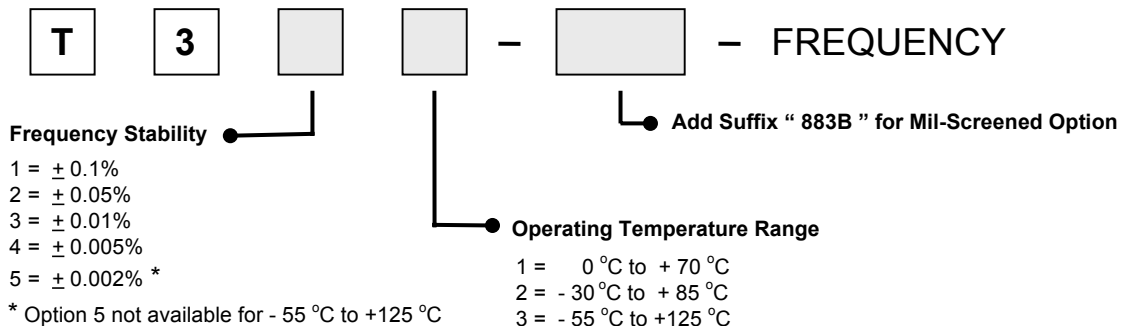

EXAMPLE: T343 - 883B - 24.000 MHz = 4 Pin Package, 10KH ECL, ± 0.005% over -55 °C to +125 °C, Mil-Screened , and 24.000 MHz