

### FEATURES

- HIGH FREQUENCY OPERATION TO 1 GHz
- LOW SUPPLY VOLTAGE: 2.2 V to 3.5 V
- LOW SUPPLY CURRENT: 5.5 mA
- AVAILABLE IN TAPE AND REEL (G08 PACKAGE)

### DESCRIPTION

The UPB587 series of devices are silicon bipolar digital prescalers which can be operated in divide-by-two, divide-by-four or divide-by-eight mode. They feature frequency response to 1 GHz, and operate from a single 3 volt supply drawing only 5.5 milliamps. The series is available in two package styles: 8 lead ceramic flat pack (UPB587B), and an 8 pin plastic mini-flat package (UPB587G). Applications include: synthesizer for DBS receiver and telecommunication applications. The low DC voltage required and power-saving current draw make them ideal for hand-held, battery-powered applications.

### TEST CIRCUIT

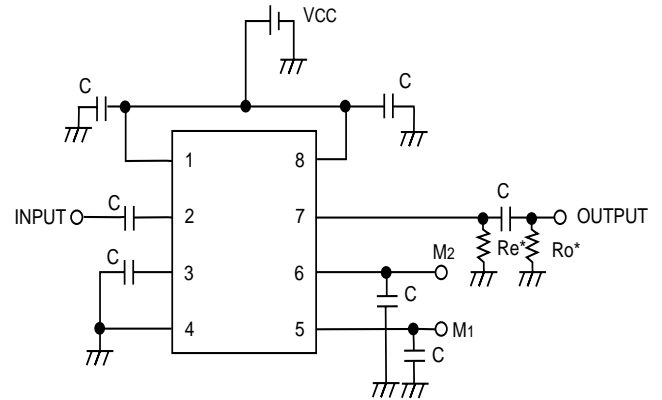

C = 2200 pF

\*Re and Ro used on test circuit as indicated below.

### BLOCK DIAGRAM

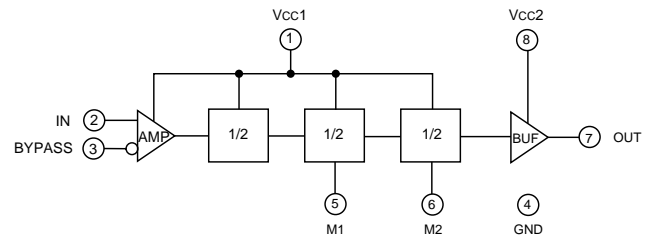

### ELECTRICAL CHARACTERISTICS<sup>1</sup> (T<sub>A</sub> = -20 to +75°C, V<sub>CC</sub> = 2.2 to 3.5 V)

PART NUMBER PACKAGE OUTLINE			UPB587B, UPB587G BF08, G08		
SYMBOLS	PARAMETERS AND CONDITIONS	UNITS	MIN	TYP	MAX
I <sub>CC</sub>	Supply Current	mA		5.5	7.5
f <sub>IN</sub>	Frequency Response at P <sub>IN</sub> = -20 to 0 dBm, Divide-by-eight	MHz	100		1000
		MHz	100		600
		MHz	100		300
	P <sub>IN</sub> = -18 to 0 dBm, Divide-by-eight	MHz	50		1000
		MHz	50		600
		MHz	50		300
P <sub>IN</sub>	Input Power at: f <sub>IN</sub> = 50 to 100 MHz	dBm	-18		0
	f <sub>IN</sub> = 100 to 300 MHz, Divide-by-two	dBm	-20		0
	f <sub>IN</sub> = 100 to 600 MHz, Divide-by-four	dBm	-20		0
	f <sub>IN</sub> = 100 to 1000 MHz, Divide-by-eight	dBm	-20		0
V <sub>O</sub>	Output Voltage, at f <sub>IN</sub> = 0.5 GHz, P <sub>IN</sub> = -10 dBm, Z <sub>O</sub> = 200 Ω	V <sub>P-P</sub>	0.1	0.3	
R <sub>TH</sub> (J-C)	Thermal Resistance, Junction to Case (UPB587B)	°C/W			50
R <sub>TH</sub> (J-A)	Thermal Resistance, Junction to Ambient (UPB587G) <sup>2</sup>	°C/W			270

#### Notes:

1. V<sub>CC1</sub> = 2.2 V to 3.5 V, V<sub>CC2</sub> = 2.2 to 3.5 V.
2. Mounted on a 5 x 5 x 0.16 mm epoxy glass circuit board.
3. To improve impedance match to a 50 Ω load, a 1.2 KΩ shunt resistor on the output line is recommended.

**ABSOLUTE MAXIMUM RATINGS<sup>1</sup>** (TA = 25°C)

SYMBOLS	PARAMETERS	UNITS	RATINGS
Vcc1, Vcc2	Supply Voltage	V	-0.5 to 4.0
VIN, VM	Input Voltage, Ratio Control Voltage	V	-0.5 to Vcc + 0.5
PIN	Input Power	dBm	+10
PT	Power Dissipation UPB587B UPB587G	W mW	1.5 (TA = +125°C) 250 (TA = +85°C)
TOP	Operating Temperature UPB587B UPB587G	°C °C	-55 to +125 -40 to +85
TSTG	Storage Temperature UPB587B UPB587G	°C °C	-65 to +200 -65 to +150

Note:

1. Operation in excess of any one of these parameters may result in permanent damage.

**RECOMMENDED OPERATING CONDITIONS**

SYMBOL	PARAMETER	UNITS	RATINGS
Vcc1, Vcc2	Supply Voltage	V	2.2 to 3.5
TOP	Operating Temperature	°C	-20 to +75

Note: Because of the high internal gain and gain compression of the UPB587, this device is prone to self-oscillation in the absence of an RF input signal. If the device will be used in an application where DC power will be applied in the absence of an RF input signal, this self-oscillation can be suppressed by any of the following means:

- \* Add a shunt resistor from the RF input line to ground. The blocking capacitor should be between the resistor and the UPB587, but physical separation should be minimized. Typically a resistor value between 50 and 100 ohms will suppress the self-oscillation.
- \* Apply a DC offset voltage of +2.0 volts to the INPUT pin. The voltage source should be isolated from the INPUT pin by a series 1000 ohm resistor.
- \* Apply a DC offset voltage of +1.0 volts to the BYPASS pin. The voltage source should be isolated from the BYPASS pin by a series 1000 ohm resistor.

All these approaches reduce the input sensitivity of the UPB587 (by as much as 3 dB for the example of a 50 ohm shunt resistor), but otherwise have no affect on the reliability or other electrical characteristics of this device.

**TYPICAL PERFORMANCE CURVES**

(TA = 25°C unless otherwise noted)

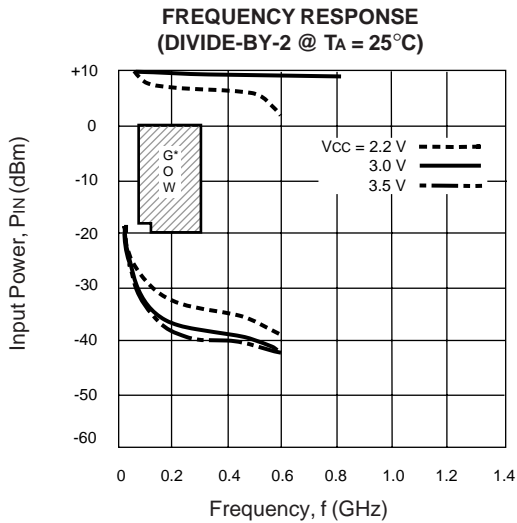

\*Guaranteed Operating Window

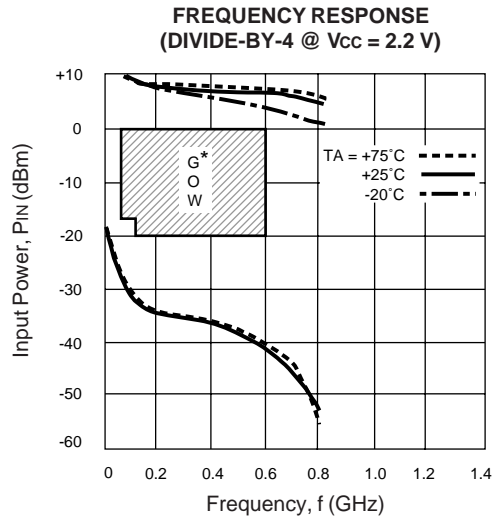
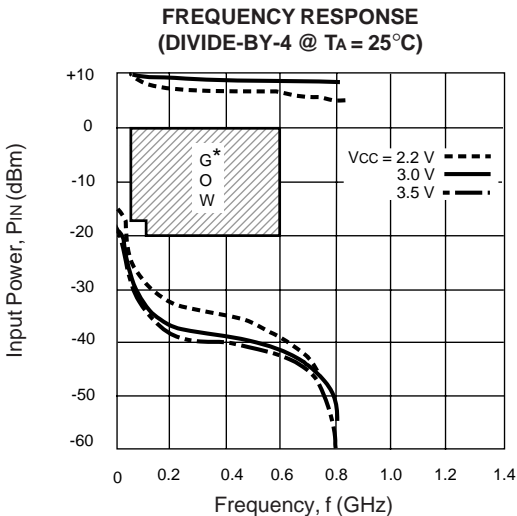
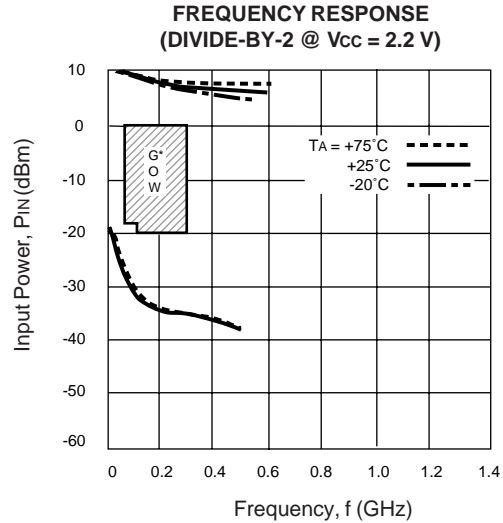

TYPICAL PERFORMANCE CURVES

FREQUENCY RESPONSE  
(DIVIDE-BY-8 @ TA = 25°C)

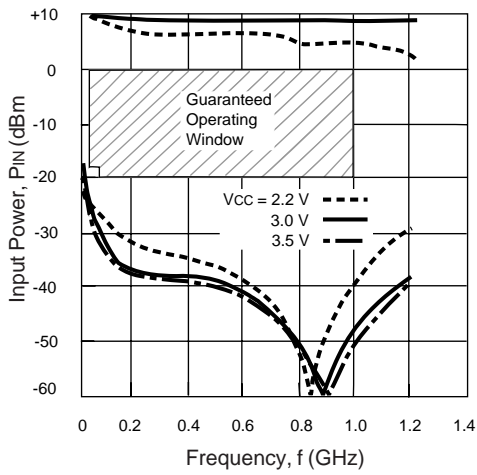

FREQUENCY RESPONSE  
(DIVIDE-BY-8 @ V<sub>CC</sub> = 2.2 V)

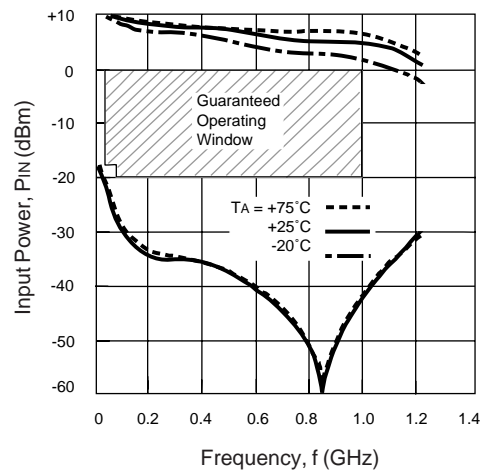

UPB587G  
OUTPUT LEVEL vs.  
FREQUENCY AND Re

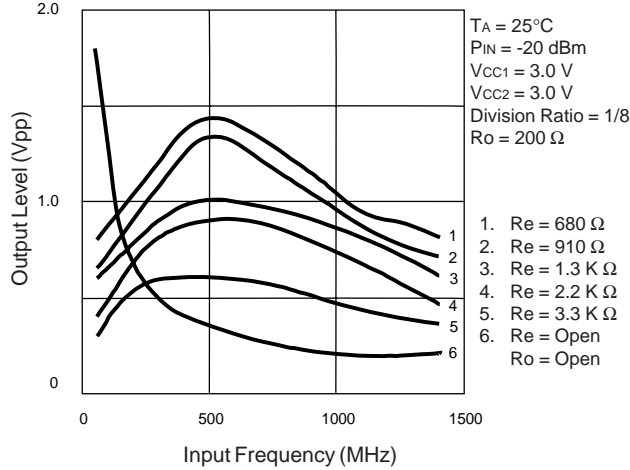

UPB587G  
OUTPUT LEVEL vs.  
FREQUENCY & SUPPLY VOLTAGE

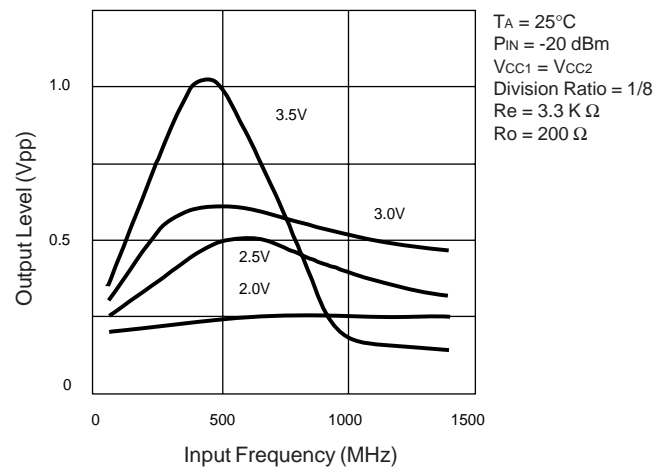

UPB587G  
OUTPUT LEVEL vs.  
FREQUENCY & DIVISION RATIO

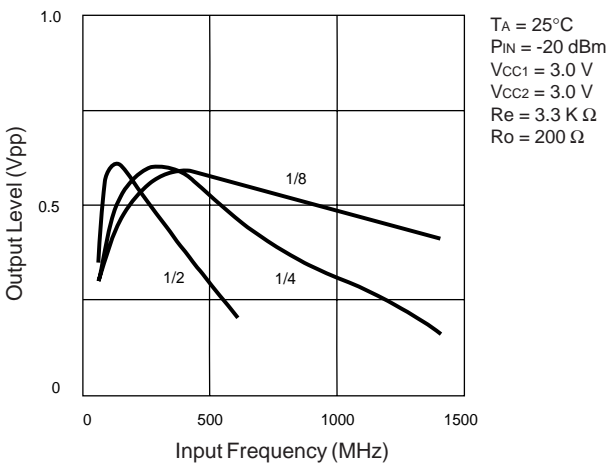

SSB PHASE NOISE vs.  
OFFSET FROM CARRIER  
f<sub>IN</sub> = 1 GHz, T<sub>A</sub> = 25°C

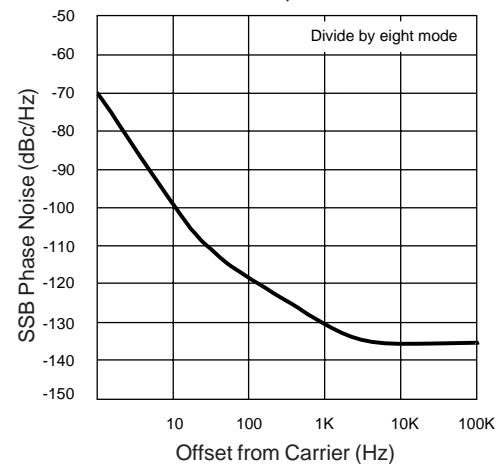

# UPB587B, UPB587G

## UPB587B INPUT AND OUTPUT S-PARAMETERS

V<sub>CC</sub> = 3.5 V, I<sub>CC</sub> = 5.5 mA, Z<sub>S</sub> = Z<sub>L</sub> = 50 Ω

### DIVIDE-BY-2 MODE

Frequency (MHz)	S <sub>11</sub>		Frequency (GHz)	S <sub>22</sub>	
	MAG	ANG		MAG	ANG
100	0.039	-106	0.10	0.597	-1
200	0.052	-109	0.20	0.619	-5
300	0.069	-112	0.30	0.623	-8
400	0.087	-115	0.40	0.634	-14
500	0.103	-118	0.50	0.636	-19

### DIVIDE-BY-4 MODE

100	0.039	-106	0.10	0.606	-1
200	0.052	-109	0.20	0.626	-2
300	0.069	-112	0.30	0.644	-6
400	0.086	-115	0.40	0.660	-12
500	0.102	-118	0.50	0.665	-19
600	0.119	-120			
700	0.135	-123			
800	0.150	-126			

### DIVIDE-BY-8 MODE

100	0.039	-106	0.10	0.606	0
200	0.052	-109	0.20	0.628	-2
300	0.069	-112	0.30	0.644	-6
400	0.086	-115	0.40	0.659	-13
500	0.102	-118	0.50	0.662	-19
600	0.119	-120			
700	0.135	-123			
800	0.150	-126			
900	0.164	-128			
1000	0.181	-130			

## UPB587G INPUT AND OUTPUT S-PARAMETERS

V<sub>CC</sub> = 3.5 V, I<sub>CC</sub> = 5.5 mA, Z<sub>S</sub> = Z<sub>L</sub> = 50 Ω

### DIVIDE-BY-TWO MODE \*

Frequency (MHz)	S <sub>11</sub>		Frequency (GHz)	S <sub>22</sub>	
	MAG	ANG		MAG	ANG
100	0.049	-107	100	0.331	9
200	0.054	-114	200	0.451	22
300	0.066	-113	300	0.480	16
400	0.079	-112	400	0.517	15
500	0.092	-111	500	0.548	13

### DIVIDE-BY-FOUR MODE \*

100	0.049	-107	100	0.377	7
200	0.055	-111	200	0.410	23
300	0.066	-112	300	0.508	22
400	0.080	-111	400	0.565	17
500	0.092	-110	500	0.599	13
600	0.106	-109			
700	0.117	-108			
800	0.130	-106			

### DIVIDE-BY-EIGHT MODE \*

100	0.049	-107	100	0.392	9
200	0.054	-113	200	0.433	21
300	0.066	-112	300	0.518	19
400	0.078	-111	400	0.569	15
500	0.091	-110	500	0.597	11
600	0.105	-109			
700	0.117	-108			
800	0.128	-106			
900	0.143	-105			
1000	0.155	-103			

\* These parameters were taken with the oscillation suppression 50 Ω resistor on the input line.

## EQUIVALENT CIRCUIT

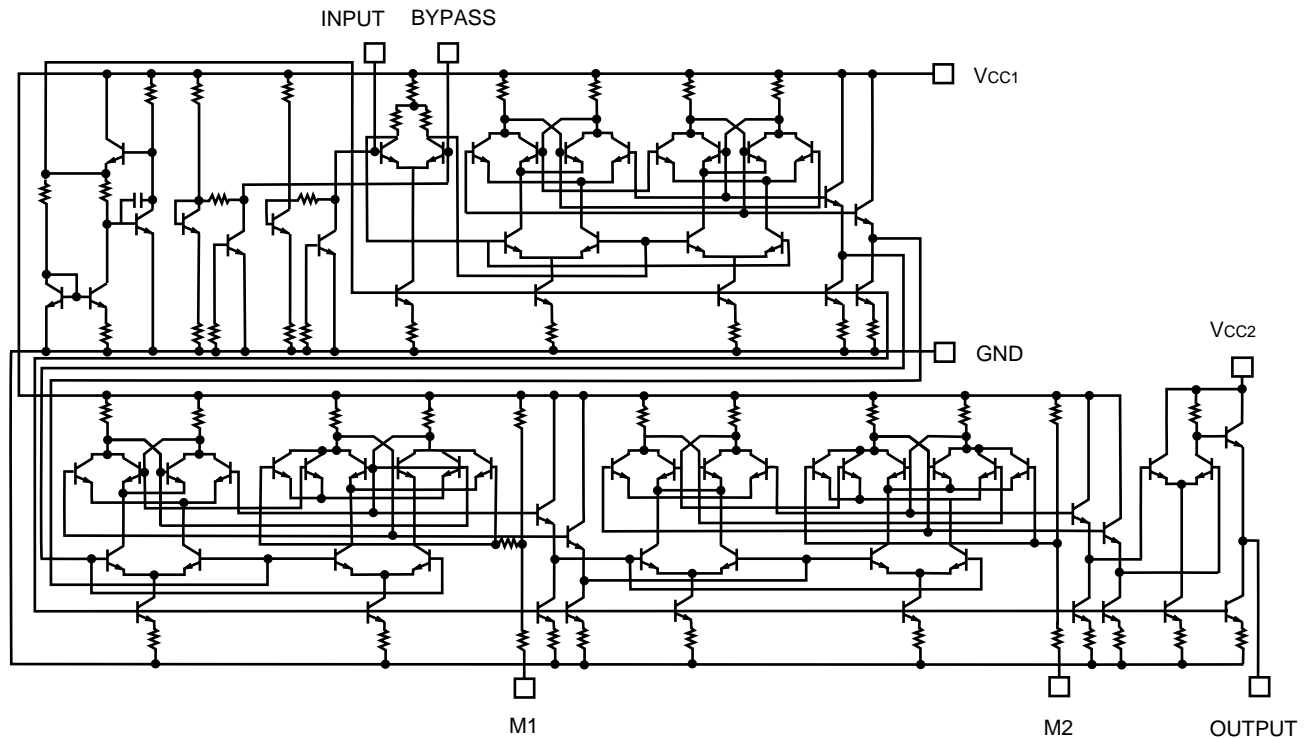

OUTLINE DIMENSIONS (Units in mm)

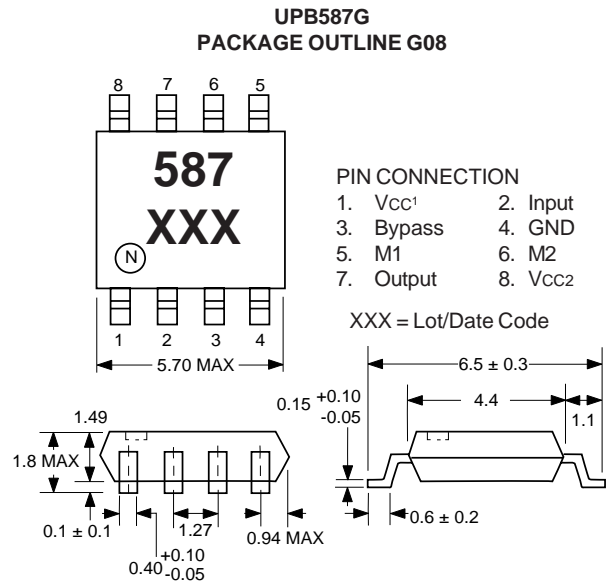
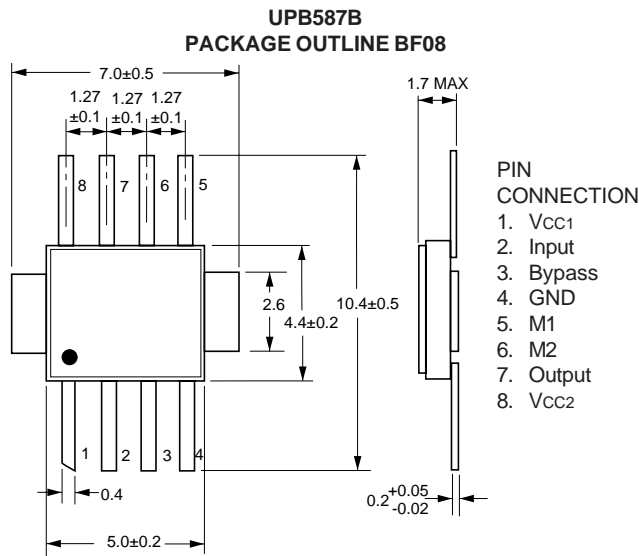

PIN DESCRIPTION

PIN NO.	SYMBOL	DESCRIPTION		
1	Vcc1	Power Supply Pin of Input Amplifier and Divider		
2	INPUT	Signal Input Pin		
3	BYPASS	Input Bypass Pin, shall be connected to ground through bypass capacitor		
4	GND	Ground Pin		
5 6	M1 M2	Division Ratio Control <sup>1</sup>		
		M1	M2	Division Ratio
		L	L	1/8
		L	H	1/4
H	H	1/2		
7	OUTPUT	Output Pin		
8	Vcc2	Power Supply of Output Buffer		

Note:

1. Control Voltages:

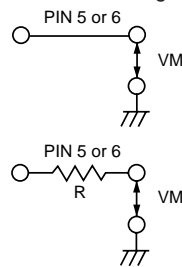

WITHOUT EXTERNAL RESISTOR

		MIN	MAX
VM	HIGH	Vcc - 0.2 V	Vcc + 0.5
	LOW	0 V	Vcc - 0.3

WITH EXTERNAL RESISTOR (R = 300 kΩ)

		MIN	MAX
VM	HIGH	Vcc	Vcc + 1.1 V
	LOW	0 V	Vcc - 0.5

ORDERING INFORMATION

PART NUMBER	QTY
UPB587G-E1	2500/Reel

EXCLUSIVE NORTH AMERICAN AGENT FOR **NEC** RF, MICROWAVE & OPTOELECTRONIC SEMICONDUCTORS

**CEL** CALIFORNIA EASTERN LABORATORIES • Headquarters • 4590 Patrick Henry Drive • Santa Clara, CA 95054-1817 • (408) 988-3500 • Telex 34-6393 • FAX (408) 988-0279  
24-Hour Fax-On-Demand: 800-390-3232 (U.S. and Canada only) • Internet: <http://WWW.CEL.COM>

DATA SUBJECT TO CHANGE WITHOUT NOTICE

PRINTED IN USA ON RECYCLED PAPER -3/97