

FEATURES

- Isolates, amplifies, & filters signals from 4-, 5, or 6-wire Linear Variable Displacement Transformers (LVDTs).
- Isolates, amplifies, & filters signals from Rotary Variable Displacement Transformers (RVDT).
- Provides an AC excitation voltage of 1V rms to 5V rms at frequencies between 1 kHz and 10kHz.
- Module circuitry can withstand 130v rms at the input screw-terminals.
- All 3B17 series modules are mix-and-match and Hot Swappable.

APPLICATIONS

- Industrial signal amplification
- Industrial signal isolation
- Industrial signal filtering

PRODUCT OVERVIEW

The 3B Series of Signal Conditioning I/o Subsystems provide a low-cost, versatile method of transferring analog transducer signals to a data acquisition, monitoring or control system without the inherent noise, non-linearity, drift and extraneous voltages. The modules are designed to directly accept analog signals from Thermocouples, RTD's, AC and DC Strain Gages, Torque Transducers, Frequency Transducers, LVDTs, millivolt or process current signals. The modules amplify, isolate, linearize and convert the transducer output signals to standardized analog inputs for high-level analog I/O subsystems. The 3B Series Subsystem consists of a 10" relay rack with universal mounting backplane and a family of plug-in (up to 16 per rack) input and output signal conditioning modules.

Eight and four channel backplanes are also available. Each backplane incorporates screw terminals for sensor inputs and current outputs and a 26-pin connector for high-level single-ended voltage outputs to the user's equipment.

The input modules feature complete signal conditioning circuitry optimized for specific sensors or analog signals and provide two simultaneous high-level analog outputs: 0 to +10V (or $\pm 10V$) and 4-20 mA (or 0-20 mA).

Rev. 0

Information furnished by Analog Devices is believed to be accurate and reliable. However, no responsibility is assumed by Analog Devices for its use, nor for any infringements of patents or other rights of third parties that may result from its use. Specifications subject to change without notice. No license is granted by implication or otherwise under any patent or patent rights of Analog Devices. Trademarks and registered trademarks are the property of their respective companies.

FUNCTIONAL BLOCK DIAGRAM

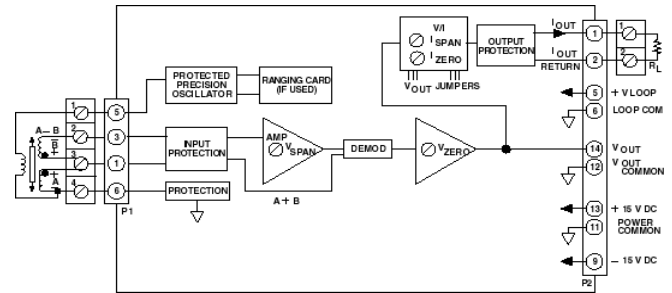

Figure 1. 3B17 Functional Block Diagram

Output modules accept 0 to +10V (or $\pm 10V$) single-ended V signals and provide an isolated 4-20 mA (or 0-20 mA) process signal. All modules feature a universal pin-out and may be readily hot-swapped under full power and interchanged without disrupting field wiring.

The Analog Devices 3B Series Signal Conditioning Subsystem is designed to easily handle signal conditioning problems in measurement and control applications. Some typical uses are in microcomputer-based data acquisition systems, programmable controllers, analog recorders, dedicated control systems, and any other applications where monitoring of temperature, pressure, flow and analog signals are required. Since each input module features two simultaneous outputs, the voltage output can be used to provide an input to a microprocessor-based data acquisition or control system while the current output can be used for analog transmission, operator interface, or an analog backup system.

Each input module is a single-channel signal conditioner which plugs into a socket on the backplane and accepts its signal from the input screw terminals. All input modules provide input protection, amplification and filtering of the input signal, accuracy of $\pm 0.1\%$, low drift of $\pm 1 \text{ uV}/^\circ\text{C}$ (low-level input modules), and feature two high-level analog outputs that are compatible with most process instrumentation. The isolated input modules also provide $\pm 1500 \text{ V}$ peak isolation.

The choice of a specific 3B module depends upon the type of input signal. Input modules are available to accept millivolt, volt, process current, thermocouple, RTD, AC and DC strain gage, frequency and LVDT inputs. The voltage output of each module is available from the system I/O connector while the current output is available on the output screw terminals.

GENERAL DESCRIPTION

The 3B17 is a wide-bandwidth single-channel signal-conditioning module which isolates, amplifies, and filters signals from 4-, 5-, or 6-wire Linear Variable Displacement Transformers (LVDTs) or Rotary Variable Displacement Transformers (RVDT). The 3B17 input module provides an AC excitation voltage of 1V rms to 5V rms at frequencies between 1 kHz and 10 kHz. All gain and zero suppression can be user-calibrated by screwdriver adjustments through the sliding door on the top of the module. Gain can vary over an extensive 256:1 range by adjusting a combination of a rotary switch and trim potentiometer. Zero suppression can vary over $\pm 5V$ from the center setting. The current output can be independently adjusted over a $\pm 5\%$ range for zero and span. In addition, the 3B17 is mix-and-match and hot-swappable with all 3B Series modules, so it can be inserted or removed from any socket in the same backplane without disrupting system power.

3B Series Custom-Ranging Program – Externally-programmable Model 3B17-00, and 3B17-D-00, enable the user to configure a special input range, excitation voltage and excitation frequency by using the optional plug-on AC1310 ranging card, which houses user-supplied resistors to determine

excitation voltage amplitude and frequency. To facilitate selecting resistors, a Windows program, 3B-CUSTOM, calculates resistor values based on the user-desired input/output ranges and AC excitation.

The 3B17 input and AC excitation output terminals are protected for up to 130V rms, protecting the computer side from damage due to field-side over-voltage faults. The LVDT input signal is amplified to give the high level output voltage. The 3B17 automatically compensates for phase errors between the primary and secondary of the LVDT or RVDT, eliminating the need for a phase adjustment and automatically rejects any residual quadrature voltages via a unique approach to error compensation which uses the sum of the two secondary winding to directly drive the demodulator. The amplitude and frequency of the AC excitation can be factory configured to meet custom needs (Model 3B17-Custom) or externally configured (Models 3B17-00 and 3B17-D-00) with the optional AC1310 plug-on custom ranging card.



Figure 2

3B17 Models Available

Model	Excitation Voltage	Excitation Frequency	Output Ranges ¹
3B17-00	Externally Programmable ²	Externally Programmable ²	-10 V to +10 V & 0 mA to 20 mA
3B17-01	3 V rms	2.5 kHz	-10 V to +10 V & 0 mA to 20 mA
3B17-02	5 V rms	5 kHz	-10 V to +10 V & 0 mA to 20 mA
3B17-03	5 V rms	7.5 kHz	-10 V to +10 V & 0 mA to 20 mA
3B17-04	1 V rms	10 kHz	-10.0 V to +10 V & 0 mA to 20 mA
3B17-Custom	*	*	*
3B17-D-00	Externally Programmable ²	Externally Programmable ²	-10 V to +10 V & 0 mA to 20 mA
3B17-D-01	3 V rms	2.5 kHz	-10 V to +10 V & 0 mA to 20 mA
3B17-D-02	5 V rms	5 kHz	-10 V to +10 V & 0 mA to 20 mA
3B17-D-03	5 V rms	7.5 kHz	-10 V to +10 V & 0 mA to 20 mA
3B17-D-04	1 V rms	10 kHz	-10 V to +10 V & 0 mA to 20 mA

¹ Output current range may be user programmed to 4 mA to 20 mA using jumper supplied.

² Requires AC1310 ranging card.

* Custom Input/Output ranges are available. Refer to configuration guide.

3B17 Specifications

(typical @ +25°C and ±15 V dc, and +24 V dc Power)

Description	Model 3B17
	Input Range
Types	4-, 5-, 6-wire LVDT or RVDT, including differential coils
Standard Range	20 mV rms to 5 V rms; See Model Table for Excitation Voltage and Frequency
Custom Excitation	V _{exc} = 1 V rms to 5 V rms V _{exc} freq. = 1 kHz to 10 kHz
	Output Range
Voltage (R _L > 2 KΩ)	-10 V to +10 V
Current (R _L = 0 to 850Ω) ¹	4 mA to 20 mA or 0 mA to 20 mA
With Input Overload	40 mA, maximum
	Accuracy²
Initial @ +25°C	±0.1% Span
Nonlinearity ²	±0.05% Span
	Stability vs. Temperature
Voltage Output	
Zero	±0.005% of Span/°C
Span	±0.01% of Span/°C
Current Output ³	
Zero	±25 ppm of Span/°C
Span	±25 ppm of Reading/°C
	LVDT Excitation⁴

Voltage	1 V rms to 5 V rms
Voltage, tolerance	±10%
Frequency	1 kHz to 10 kHz, ±15%
Drive	20 mA rms, minimum
Harmonic Distortion	< 0.5%

Span Adjustment Range	256:1
Zero Adjustment Range	±5 V

Current Output Calibration⁴

Zero and Span Adjustment Range	±5% of Span
Input Bias Current	+1 µA
Input Resistance	100 MΩ
Bandwidth⁵, -3 dB	100 Hz
Output Rise Time, 10% to 90% Span	5 ms

Input Protection, Signal and Excitation Voltage

Continuous	130 V rms maximum
Transient	ANSI/IEEE C37.90.1-1989
Voltage Output Protection	Continuous Short to Ground
Current Output Protection	130 V rms, continuous

±15 V dc Supplies

Rated Operation	±(13 V dc to 18 V dc)
Current	±65 mA plus LVDT Current ⁷
Sensitivity	±0.03% span/V

+24 V dc Loop Supply

Rated Operation	+13.5 V dc to +30 V dc
Current	+27 mA @ $I_{out} = 20$ mA
Sensitivity	±0.001% span/V

Mechanical Dimensions

3.15" x 3.395" x 0.775"
80.0 mm x 86.2 mm x 19.7 mm)

Environmental

Temperature Range	
Rated Performance	-25°C to +85°C
Storage	-55°C to +85°C
Relative Humidity, 24 hours	0 to 95% @ +60°C non-condensing
RFI Susceptibility	±0.5% Span error @ 400 MHz, 5 Watt, 3 ft

¹ For a 0 mA to 20 mA range, a typical minimum output current is 10 µA.

² Includes the combined effects of repeatability, hysteresis, and nonlinearity.

³ With respect to the voltage output.

⁴ A wide range of custom zero suppression and span is available with the 3B17-00 model, using the AC1310 ranging card.

⁵ Bandwidth can be set for up to 1/10 the excitation frequency when ordering Model 3B17-custom.

⁶ +24 V dc loop power is required for driving the current output at loads up to 850Ω. If a current output load of 400Ω or less is applied, +15 V dc is sufficient for loop power. If only voltage output is used, loop power is not required.

⁷ Typical supply current is ±40 mA per module plus ±5 mA for the LVDT drive current. To calculate supply current requirements from LVDT currents, use 75% of the LVDT rms current.

Specifications subject to change without notice.

PIN CONFIGURATIONS AND FUNCTIONAL DESCRIPTIONS

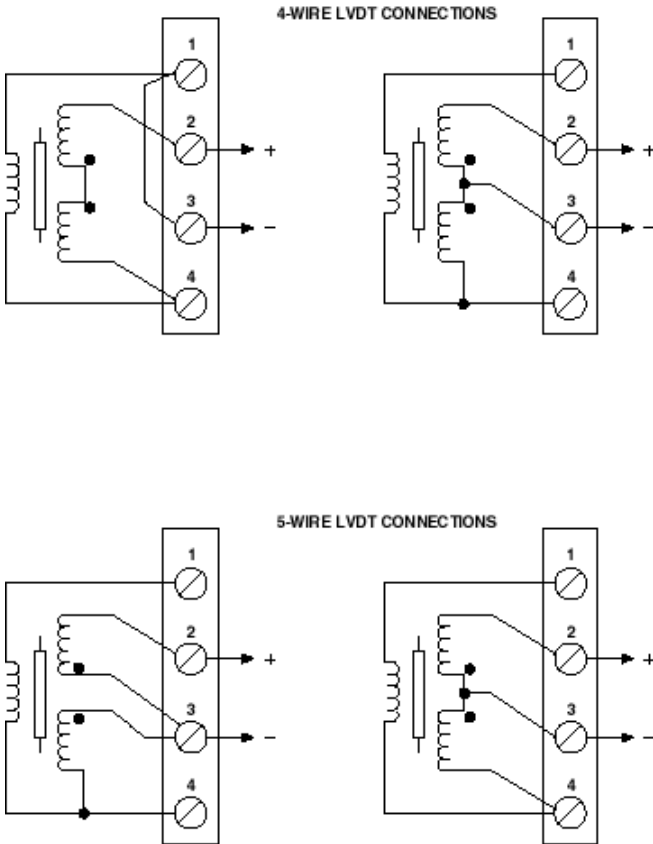

Figure 3 3B17 Input Field Connections

Table 1. Pin Function Descriptions—

Pin No.	Description
1	LO IN
2	CJC OUT
3	HI IN
4	CJC COM

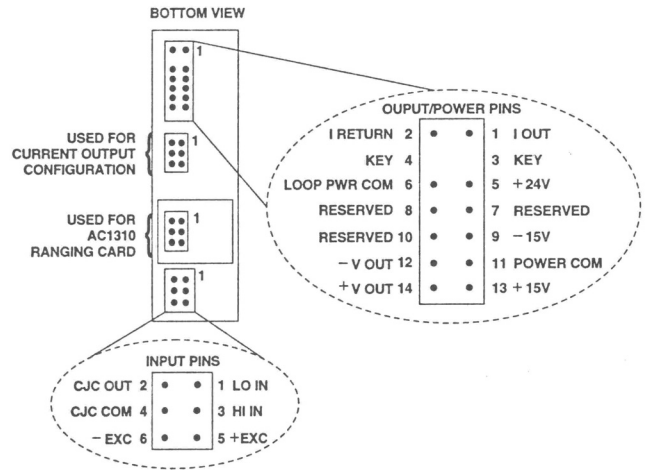

Figure 4 . Model 3B Series Module, with pin-out assignments.

ESD CAUTION

ESD (electrostatic discharge) sensitive device. Electrostatic charges as high as 4000 V readily accumulate on the human body and test equipment and can discharge without detection. Although this product features proprietary ESD protection circuitry, permanent damage may occur on devices subjected to high energy electrostatic discharges. Therefore, proper ESD precautions are recommended to avoid performance degradation or loss of functionality.



OUTLINE DIMENSIONS



Figure 5. Outline Dimensions

NOTES

NOTES