

3 Phase Bridge Modules EH150Y, EH150Q-

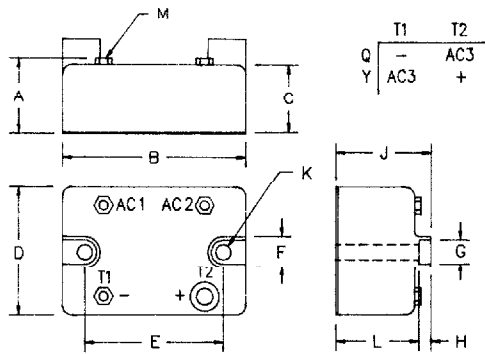

Dim.	Inches		Millimeter		Notes
	Minimum	Maximum	Minimum	Maximum	
A		1.10		27.94	
B	2.25	2.40	57.15	60.96	
C	.930	.950	23.62	24.13	
D	1.740	1.760	44.19	44.70	
E	1.883	1.887	47.82	47.92	
F	.495	.505	12.57	12.83	
G	.325	.335	8.25	8.50	
H	.215	.225	5.46	5.71	
J	1.270	1.300	32.25	33.02	
K	.198	.208	5.02	5.28	Dia.
L	1.055	1.075	26.79	27.30	
M	#10 32 TAPPED HOLES				

Note: (+) or (-) terminal 1/4-20 tapped hole.

Microsemi Catalog Number	Repetitive Peak Reverse Voltage	
EH15002Y	EH15002Q-	200
EH15004Y	EH15004Q-	400
EH15006Y	EH15006Q-	600
EH15008Y	EH15008Q-	800
EH15010Y	EH15010Q-	1000
EH15012Y	EH15012Q-	1200
EH15014Y	EH15014Q-	1400

Both Q- and Y Part Numbers are needed to complete 3 ϕ Rectification

- Maximum Surge Current 1600 Amps
- High Terminal-to-base Isolation of 2500VAC RMS
- Available to 1400 Volts
- Mounting Bolts Isolated From Power Terminals

E

Electrical Characteristics		
Maximum DC output current, 3 phase	I_o 150 Amps	$T_C = 128^\circ C, 120^\circ C$ conduction, $R_{\theta JC} = 0.7^\circ C/W$
Maximum surge current per diode	IFSM 1600 Amps	8.3ms, half sine, $T_J = 175^\circ C$
Max. I^2t for fusing	I^2t 10600 A ² s	
Max. peak forward voltage per diode	V _{FM} 1.0 Volt	I _{FM} = 50A; $T_J = 25^\circ C^*$
Max. peak reverse current per diode	I _{RM} 5 μA	V _{RRM} , $T_J = 25^\circ C$
Max. peak reverse current per diode	I _{RM} 3 mA	V _{RRM} , $T_J = 150^\circ C^*$
Minimum isolation voltage	V _{ISOL} 2500 V _{RMS}	any terminal-to-base

*Pulse test: Pulse width 300 μ sec, Duty cycle 2%

Thermal and Mechanical Characteristics		
Storage temp range	T _{STG}	-40 $^\circ C$ to + 175 $^\circ C$
Operating junction temp range	T _J	-40 $^\circ C$ to + 175 $^\circ C$
Max thermal resistance per diode	R _{θJC}	0.7 $^\circ C/W$ Junction to case
Typical thermal resistance per diode	R _{θJC}	0.5 $^\circ C/W$ Junction to case
Max mounting torque		20 inch pounds
Typical thermal resistance	R _{θCS}	0.07 $^\circ C/W$ Case to sink
Weight		6.4 ounces (182 grams) typical

Microsemi Corp.
Colorado

PH: 303-469-2161
FAX: 303-466-3775

E-71

EH150Y, EH150Q-

Figure 1
Typical Forward Characteristics - Per Diode

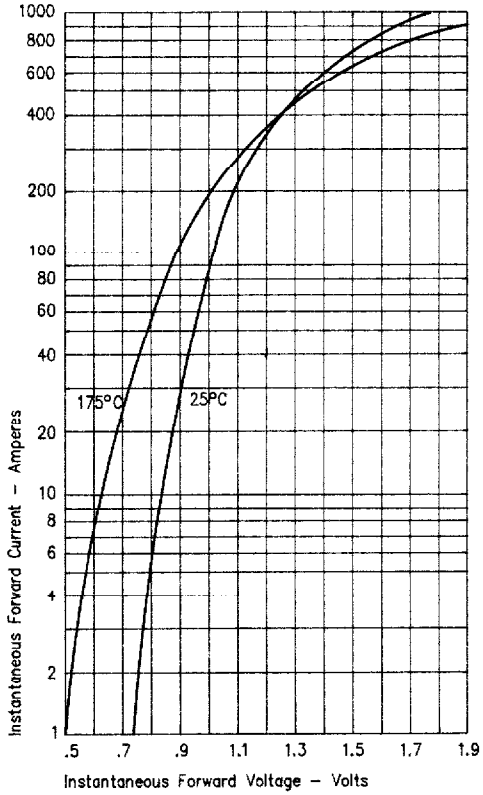

Figure 3
Maximum Nonrepetitive Surge Current - Per Diode

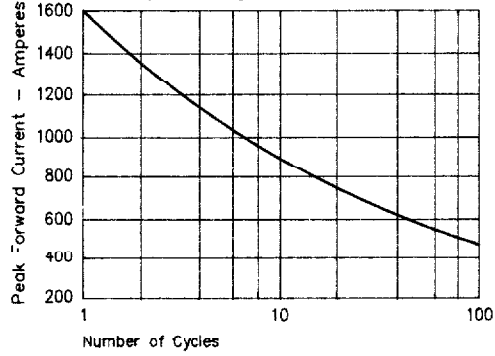

Figure 2
Forward Current Derating - Per Diode

