

# Type FCP

## Surface Mount Film Capacitors

### FCP Surface Mount Highlights:

- Capacitance Range of 100 pF to .22 $\mu$ F
- Standard EIA sizes 0603 thru 2416
- 16 and 50 Vdc Voltage Ratings
- Operating Temp. Range: -55 to 125 °C
- Capacitance Change from  
-55°C to 105°C  $\leq \pm 1.5\%$

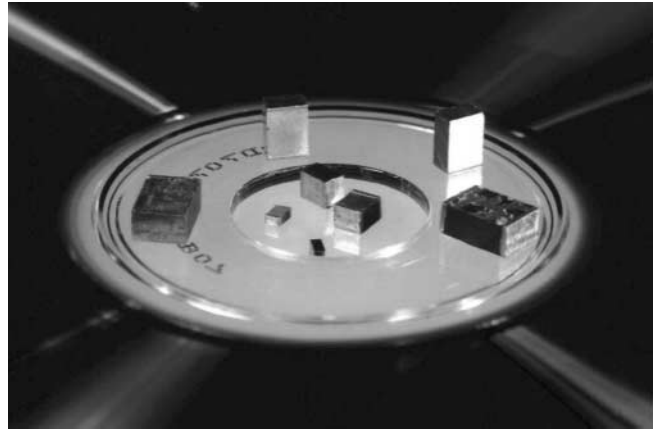

Type FCP stacked metallized polyphenylene sulfide (PPS) film capacitors offer high capacitance per unit volume, stable capacitance and D.F. over a wide temperature range, and excellent high frequency performance. Type FCP capacitors conform to standard EIA 0603, 0805, 1206, 1210, 1913 & 2416 surface mount case sizes and are packaged on tape and reel.

### Specifications

#### Nominal Capacitance Range:

100 pF to 0.22  $\mu$ F (1 kHz at  $\leq 5$  Vrms)

#### Capacitance Tolerance:

$\pm 5\%$  (J) Standard,  $\pm 2\%$  (G) Optional

#### Rated Voltage:

16 and 50 Vdc

#### Dissipation Factor (Tan $\delta$ ):

0.6% Max. (1 kHz at  $\leq 5$  Vrms)

#### Operating Temperature Range:

-55°C to +125°C

(See Voltage derating chart for .12 - .22  $\mu$ F above 105°C)

#### Dielectric Strength:

175% of rated Vdc for 5 seconds

#### Insulation Resistance:

3000 M $\Omega$  Min. at 20°C, after 60 seconds.

(16 Vdc rated, test 10 Vdc; 50 Vdc rated, test 50 Vdc)

#### Construction:

Stacked Metallized Polyphenylene Sulfide film.

#### Life Test:

Capacitors subjected to 1000 hours of maximum rated temperature and 125% of the rated voltage will not have any significant visual damage, the capacitance will be within  $\pm 2\%$  of the initial measured value, DF will be a maximum of 0.66%, and IR will be a minimum of 1000 Megohms.

#### Moisture Resistance:

Capacitors subjected to 1000 hours at 40°C and 90% - 95% RH and rated voltage will not have any significant visual damage, will withstand 1.3 times the rated voltage for one minute, the capacitance will be within  $\pm 2\%$  of the initial measured value, DF will be a maximum of 0.9%, and IR will be a minimum of 1000 Megohms.

#### Resistance to Soldering Heat:

Capacitors subjected to a 260°C reflow soldering for 5 seconds will not have any significant visual damage, dielectric strength will be as specified, the capacitance will be within  $\pm 3\%$  of the initial measured value, DF will be a maximum of 0.66%, and IR will be a minimum of 1000 Megohms.

[www.DataSheet4U.com](http://www.DataSheet4U.com)

# Type FCP

## Surface Mount Film Capacitors

### Ratings Table

Capacitance			16 Vdc		50 Vdc	
( $\mu$ F)	(nF)	(pF)	CDE Part Number	Case Code	CDE Part Number	Case Code
0.00010	0.10	100	FCP0603C101J-K1	0603	FCP0805H101J-J1	0805
0.00012	0.12	120	FCP0603C121J-K1		FCP0805H121J-J1	
0.00015	0.15	150	FCP0603C151J-K1		FCP0805H151J-J1	
0.00018	0.18	180	FCP0603C181J-K1		FCP0805H181J-J1	
0.00022	0.22	220	FCP0603C221J-K1		FCP0805H221J-J1	
0.00027	0.27	270	FCP0603C271J-K1		FCP0805H271J-J1	
0.00033	0.33	330	FCP0603C331J-K1		FCP0805H331J-J1	
0.00039	0.39	390	FCP0603C391J-K1		FCP0805H391J-J1	
0.00047	0.47	470	FCP0603C471J-K1		FCP0805H471J-J1	
0.00056	0.56	560	FCP0603C561J-K1		FCP0805H561J-J1	
0.00068	0.68	680	FCP0603C681J-K1		FCP0805H681J-J1	
0.00082	0.82	820	FCP0603C821J-K1		FCP0805H821J-J1	
0.0010	1.0	1000	FCP0603C102J-K1		FCP0805H102J-J1	
0.0012	1.2	1200	FCP0603C122J-K1		FCP0805H122J-J1	
0.0015	1.5	1500	FCP0603C152J-K1		FCP0805H152J-J1	
0.0018	1.8	1800	FCP0603C182J-K1		FCP0805H182J-J1	
0.0022	2.2	2200	FCP0603C222J-K1		FCP0805H222J-J1	
0.0027	2.7	2700	FCP0603C272J-K1	FCP0805H272J-J1		
0.0033	3.3	3300	FCP0805C332J-J1	0805	FCP1206H332J-H1	1206
0.0039	3.9	3900	FCP0805C392J-J1		FCP1206H392J-H1	
0.0047	4.7	4700	FCP0805C472J-J1		FCP1206H472J-H1	
0.0056	5.6	5600	FCP0805C562J-J1		FCP1206H562J-H1	
0.0068	6.8	6800	FCP0805C682J-J1		FCP1206H682J-H1	
0.0082	8.2	8200	FCP0805C822J-J2		FCP1206H822J-H2	
0.01	10.0	10000	FCP0805C103J-J2	FCP1206H103J-H2		
0.012	12.0	12000	FCP1206C123J-H1	1206	FCP1210H123J-G1	1210
0.015	15.0	15000	FCP1206C153J-H1		FCP1210H153J-G1	
0.018	18.0	18000	FCP1206C183J-H1		FCP1210H183J-G2	
0.022	22.0	22000	FCP1206C223J-H1		FCP1210H223J-G2	
0.027	27.0	27000	FCP1206C273J-H2		FCP1210H273J-G2	
0.033	33.0	33000	FCP1206C333J-H2		FCP1210H333J-G3	
0.039	39.0	39000	FCP1206C393J-H3		FCP1210H393J-G3	
0.047	47.0	47000	FCP1206C473J-H3	1210	FCP1913H473J-E1	1913
0.056	56.0	56000	FCP1210C563J-G2		FCP1913H563J-E2	
0.068	68.0	68000	FCP1210C683J-G2		FCP1913H683J-E2	
0.082	82.0	82000	FCP1210C823J-G3		FCP1913H823J-E4	
0.10	100.0	100000	FCP1210C104J-G3	FCP1913H104J-E3		
0.12	120	120000		FCP2416H124J-D1	2416	
0.15	150	150000		FCP2416H154J-D3		
0.18	180	180000		FCP2416H184J-D4		
0.22	220	220000		FCP2416H224J-D5		

# Type FCP

## Surface Mount Film Capacitors

### Typical Temperature Characteristics

### Typical Frequency Characteristics

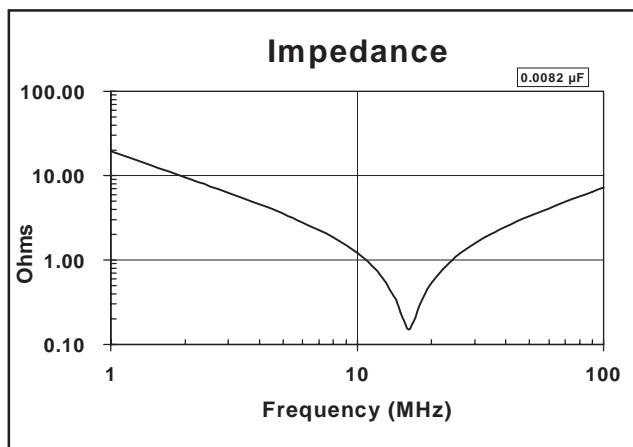
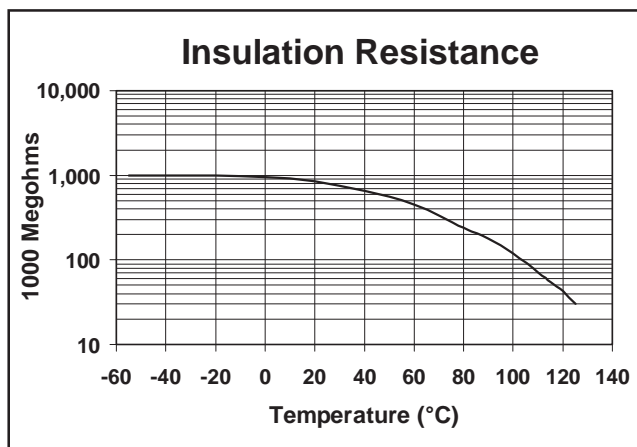
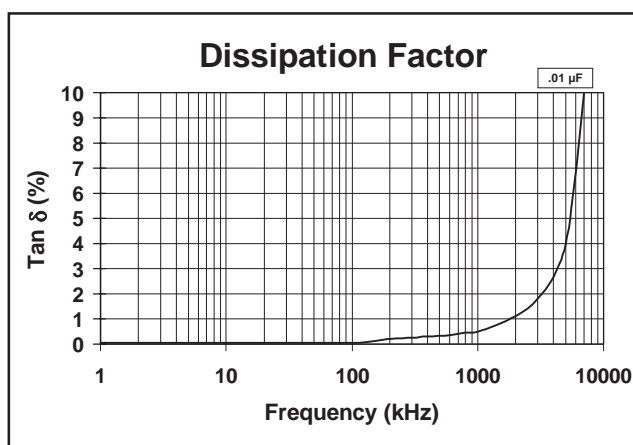
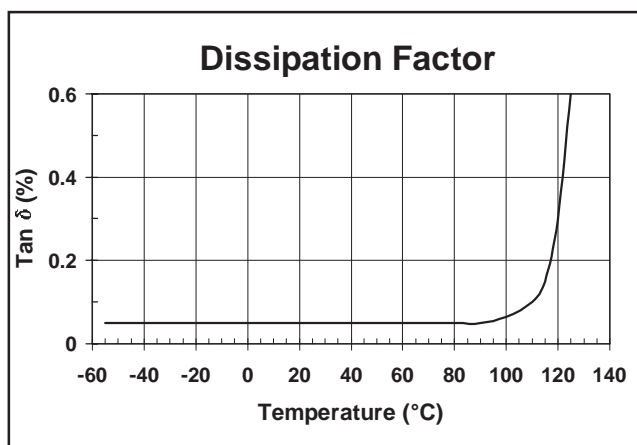
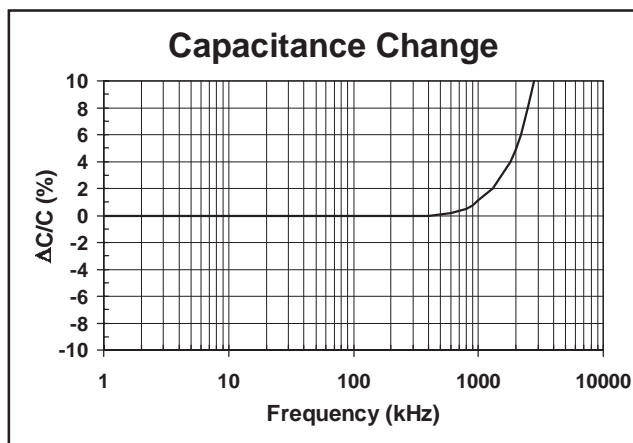
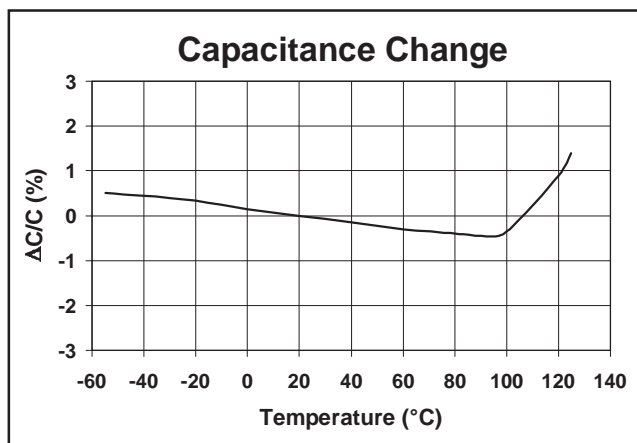

# Type FCP

## Surface Mount Film Capacitors

### Outline Dimensions

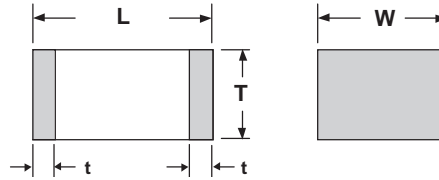

Case Size Code	Outline Dimensions (in.)				Case Size (metric)	Outline Dimensions (mm)				Packaging Code	
	L±0.008	W	T±0.008	t		L±0.2	W	T±0.2	t		
0603	0.063	0.032±0.006	0.028±0.006	0.014±0.008	1608	1.6	0.80±0.15	0.7±0.15	0.35±0.2	K1	
0805	0.079	0.049±0.008	0.035	0.018±0.010	2012	2.0	1.25±0.2	0.9	0.45±0.25	J1	
			0.043					1.1			J2
1206	0.126	0.063±0.008	0.035	0.026±0.012	3216	3.2	1.6±0.2	0.9	0.65±0.3	H1	
			0.043					1.1			H2
			0.059					1.5			H3
1210	0.126	0.098±0.008	0.043	0.026±0.012	3225	3.2	2.5±0.2	1.1	0.65±0.3	G1	
			0.059					1.5			G2
			0.083					2.1			G3
1913	0.189	0.130±0.012	0.055	0.014±0.008	4833	4.8	3.3±0.3	1.4	0.35±0.2	E1	
			0.079					2.0			E2
			0.110					2.8			E3
			0.094					2.4			E4
2416	0.236	0.161±0.012	0.071	0.014±0.008	6041	6.0	4.1±0.3	1.8	0.35±0.2	D1	
			0.094					2.4			D3
			0.110					2.8			D4
			0.126					3.2			D5

### Pulse Handling Capability

Capacitance (µF)	Voltage (Vdc)	dV/dt (volts/µsec)	Capacitance (µF)	Voltage (Vdc)	dV/dt (volts/µsec)	Capacitance (µF)	Voltage (Vdc)	dV/dt (volts/µsec)
0.0001	16	420	0.01	16	52	0.00082	50	440
0.00012	16	390	0.012	16	48	0.001	50	400
0.00015	16	350	0.015	16	43	0.0012	50	370
0.00018	16	325	0.018	16	40	0.0015	50	340
0.00022	16	295	0.022	16	37	0.0018	50	310
0.00027	16	270	0.027	16	33	0.0022	50	270
0.00033	16	245	0.033	16	31	0.0027	50	260
0.00039	16	225	0.039	16	28	0.0033	50	240
0.00047	16	205	0.047	16	26	0.0039	50	220
0.00056	16	193	0.056	16	24	0.0047	50	200
0.00068	16	175	0.068	16	22	0.0056	50	190
0.00082	16	160	0.082	16	20	0.0068	50	170
0.001	16	150	0.1	16	19	0.0082	50	160
0.0012	16	135	0.0001	50	1100	0.01	50	145
0.0015	16	123	0.00012	50	1050	0.012	50	135
0.0018	16	115	0.00015	50	940	0.015	50	120
0.0022	16	105	0.00018	50	890	0.018	50	110
0.0027	16	95	0.00022	50	800	0.022	50	100
0.0033	16	86	0.00027	50	730	0.027	50	94
0.0039	16	80	0.00033	50	690	0.033	50	86
0.0047	16	74	0.00039	50	610	0.039	50	78
0.0056	16	68	0.00047	50	580	.047 - 0.1	50	180
0.0068	16	62	0.00056	50	520	0.12 - 0.22	50	130
0.0082	16	58	0.00068	50	480			

# Type FCP

## Surface Mount Film Capacitors

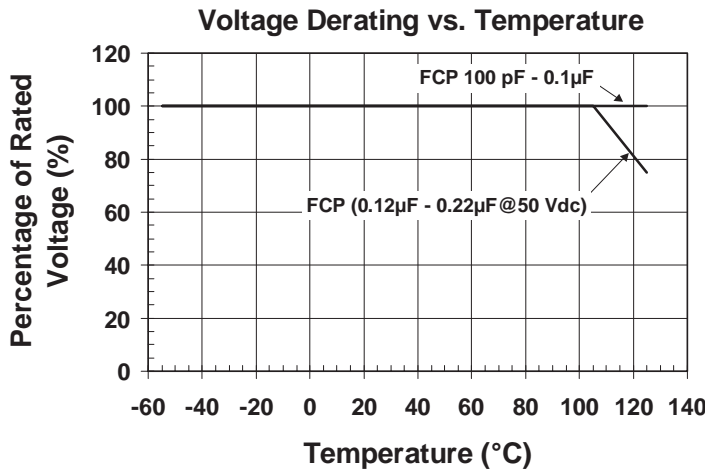

If the temperature on the surface of the capacitor is above 105°C, then the maximum voltage for FCP 50 Vdc ratings from .12 µF to .22µF must be derated linearly from full rated voltage at 105°C to 75% of the rated voltage at 125°C.

## Vrms vs. Frequency

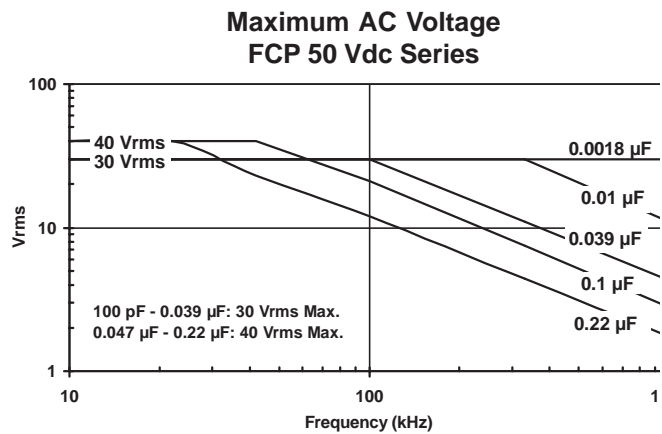
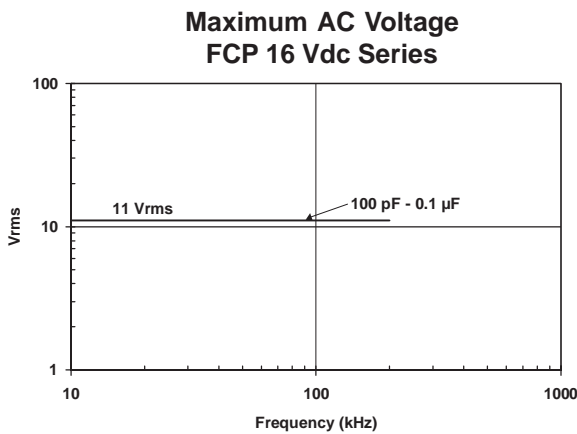

The capacitor surface temperature should not exceed 125°C.

## Typical Applications

**Resonant Circuit for Inverter: Liquid Crystal Display Panel**  
Higher efficiency in battery operated devices.

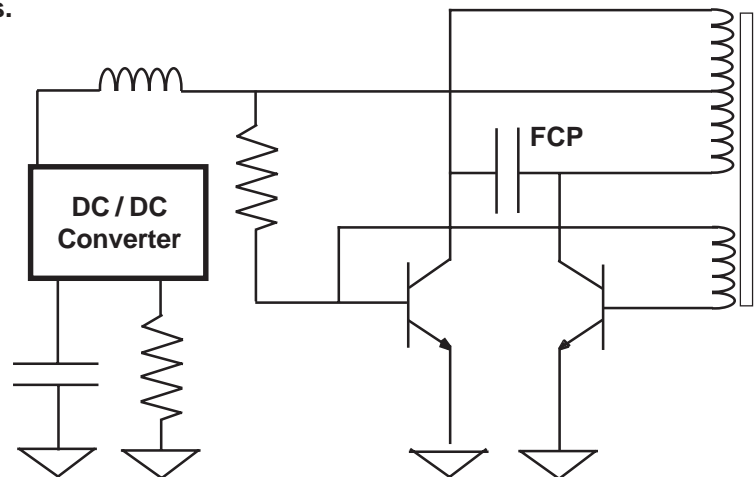
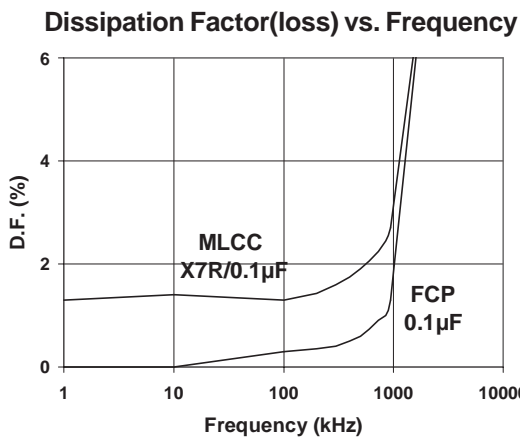

Very low losses and stable temperature characteristics make film chip capacitors the best choice for resonant circuit applications.

# Type FCP

## Surface Mount Film Capacitors

### Typical Applications

#### Filtering Capacitor for xDSL:

Impedance vs. Frequency (Typical Performance FCP Series)

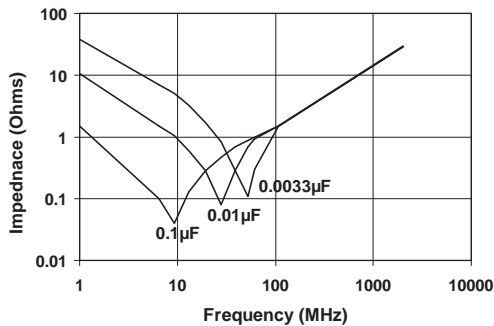

Telephone Line

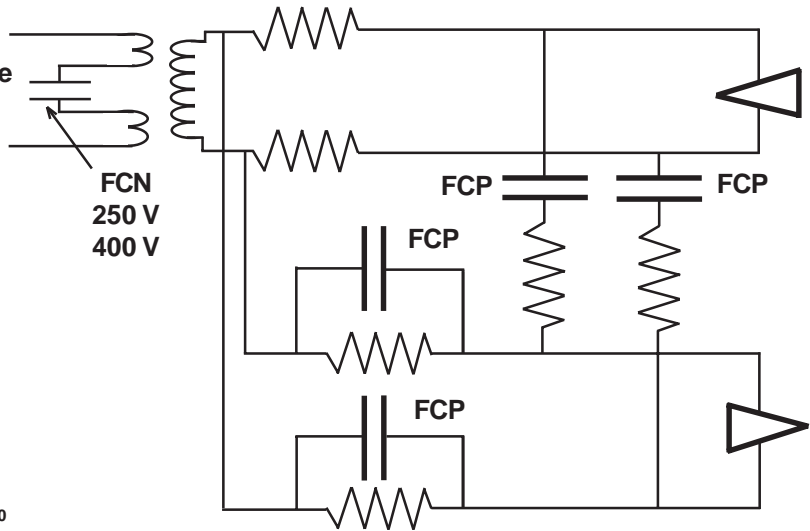

FCN  
250 V  
400 V

Capacitance Change vs. Bias Voltage

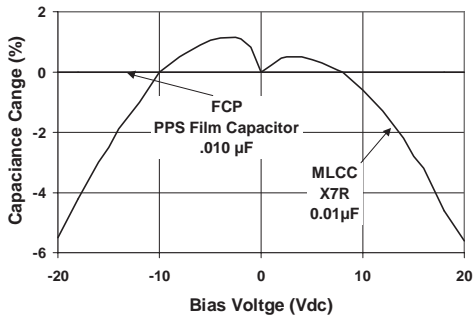

Capacitance Change vs. Temperature

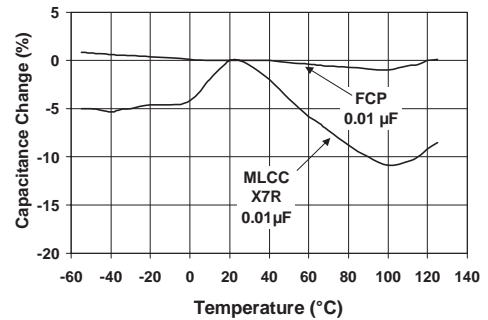

The capacitance of SMT film chips is much more stable with applied voltage and with changes in temperature than multilayer ceramic capacitors. Add in the low e.s.r. characteristics of film chips and the final result is improved performance in filter circuit applications.

#### PLL Circuit: Cellular phone, Blue Tooth, Data Communication Cards

Lock-up Time

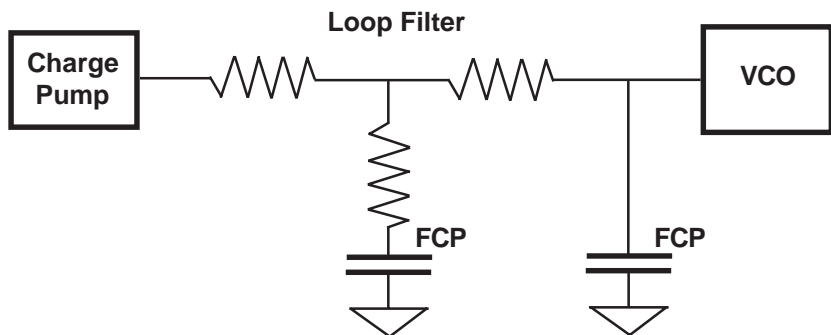
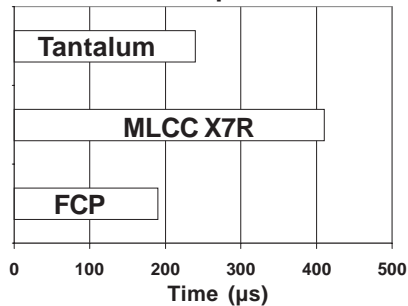

In PLL circuit applications, FCP SMT film capacitor advantages are tight tolerance on the capacitance value, stable capacitance with temperature, faster lock-up times, and no noise due to piezoelectric effects

# Application Guide, Film Chip Capacitors

## Reel Quantity and Dimensions

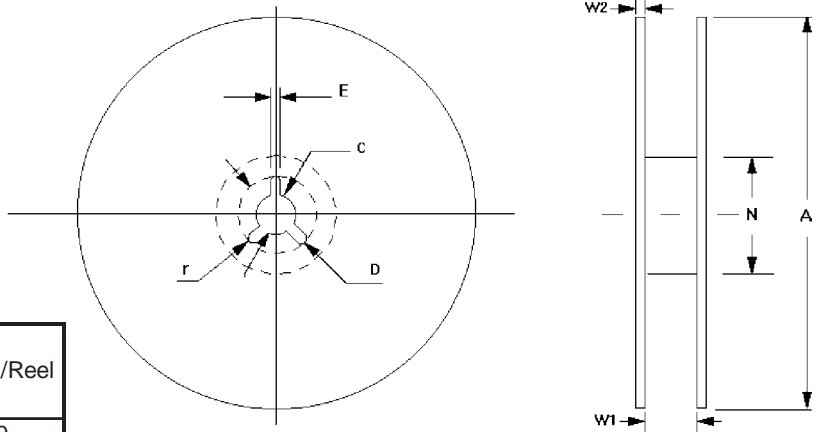

Packaging Code	Tape Width [mm]	Reel Diameter [in.(mm)]	Quantity/Reel
K1	8	7 (178)	4000
J1, J2	8	7 (178)	3000
H1, H2	8	7 (178)	3000
H3	8	7 (178)	2000
G1, G2, G3	8	7 (178)	2000
E1, E2	12	13 (330)	3000
E3, E4	12	13 (330)	2000
D1, D2	12	13 (330)	3000
D3, D4, D5	12	13 (330)	2000
B, Z	12	13 (330)	1500
U, V, X, Y	16	13 (330)	1000
S, T	24	13 (330)	750

Symbol	Reel Dimensions (mm)			
	8 mm Tape	12 mm Tape	16 mm Tape	24 mm Tape
A	178	330	330	330
C	13	13	13	13
D	21	21	21	21
E	2	2	-	-
N	60	80	80	80
r	1	1	-	-
W1	9.5	14	17.5	25.5
W2	1.2	2	-	-

## Tape Dimensions

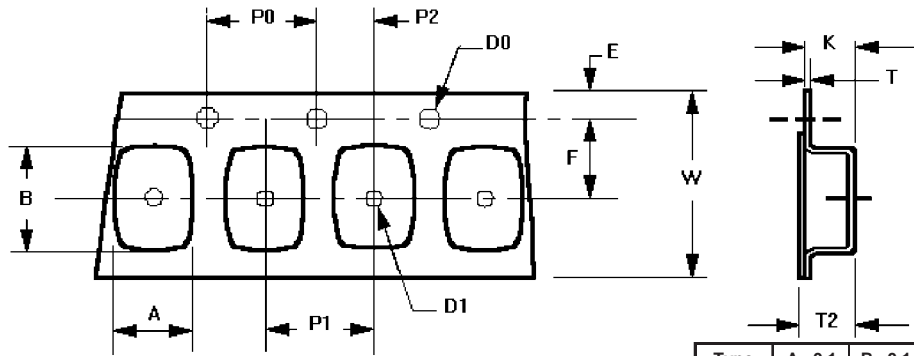

Symbol	Tape Dimensions (mm)					
	K1	J1,J2, H1,H2,H3,G1,G2,G3	E1, E2 E3, E4	D1, D2, D3, D4, D5, B, Z	U, V X, Y	S, T
W	8	8	12	12	16	24
F	3.5	3.5	5.5	5.5	7.5	11.5
E	1.75	1.75	1.75	1.75	1.75	1.75
P1	-	4	8	8	12	16
P2	2	2	2	2	2	2
P0	4	4	4	4	4	4
D0	1.5	1.5	1.5	1.5	1.5	1.5
D1	-	1	1.5	-	1.5	1.5

Type	A ±0.1	B ±0.1	T ±0.05	T2 ±0.2	K ±0.1
K1	1.0	1.85	0.2	1.1	1.0
J1	1.55	2.3	0.25	1.3	1.2
J2	1.55	2.3	0.25	1.5	1.4
H1, H2	1.9	3.5	0.25	1.5	1.4
H3	1.9	3.5	0.25	1.9	1.8
G1, G2	2.8	3.5	0.25	1.9	1.8
G3	2.8	3.5	0.25	2.5	2.4
E1	3.8	5.1	0.30	2.0	1.9
E2	3.8	5.1	0.30	2.6	2.5
E3, E4	3.8	5.1	0.30	3.4	3.5
D1	4.6	6.3	0.30	2.7	2.6
D3, D4	4.6	6.3	0.30	3.5	3.4
D5	4.6	6.3	0.30	4.6	4.5
B	5.5	6.3	0.30	5.1	5.0
Z	5.5	7.5	0.30	4.7	4.6
X, Y	6.91	8.43	0.34±.02	5.69	5.64
U, V	8.94	10.54	0.34±.02	5.8	5.75
S, T	10.8	16.0	0.36±.02	5.82	5.77

# Application Guide, Film Chip Capacitors

## Recommended Land Patterns

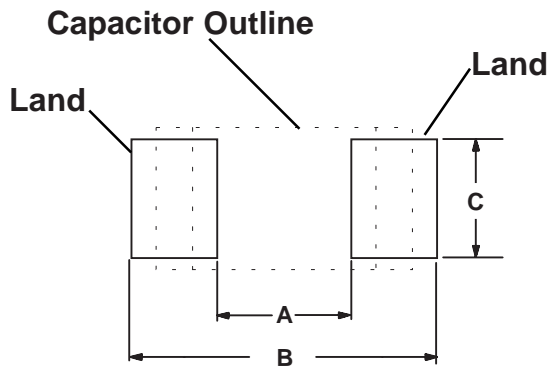

Case Size Code	Land Dimensions [in.(mm)]		
	A	B	C
0603	0.024 (0.6)	0.08 (2.0)	0.028 (0.7)
0805	0.03 (0.8)	0.09 (2.4)	0.04 (1.1)
1206	0.07 (1.8)	0.14 (3.6)	0.06 (1.4)
1210	0.07 (1.8)	0.14 (3.6)	0.09 (2.3)
1913	0.10 (2.6)	0.26 (6.6)	0.12 (3.0)
2416	0.15 (3.8)	0.31 (7.8)	0.15 (3.8)
2420	0.15 (3.8)	0.31 (7.8)	0.18 (4.6)
2820	0.18 (4.5)	0.35 (9.0)	0.18 (4.6)
2825	0.18 (4.5)	0.35 (9.0)	0.22 (5.7)
3022	0.20 (5.1)	0.38 (9.7)	0.20 (5.0)
3925	0.28 (7.2)	0.47 (11.9)	0.22 (5.7)
3931	0.28 (7.2)	0.47 (11.9)	0.28 (7.2)
6031	0.50 (12.6)	0.68 (17.3)	0.28 (7.2)
6040	0.50 (12.6)	0.68 (17.3)	0.35 (9.0)

## Soldering Information

<b>Soldering</b>		
Reflow method only, not to exceed two reflow processings. Halogen content of flux, solder paste and cleaner should be less than 0.1% for each.		
<b>Cleaning Solvent</b>		
Isopropyl alcohol		
<b>Cleaning Method</b>		
	Temperature	Time
Immersion	25°C	<5min.
Vapor	<50°C	<5min.
Ultrasonic	<50°C	<5min.
Dry the circuit board completely after cleaning.		

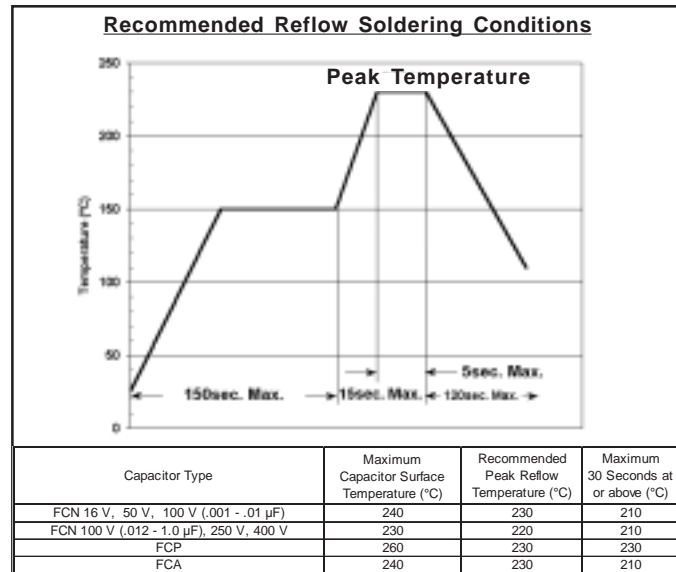

## Ordering Information

Type	Case Size	Voltage Code	Capacitance Code	Tolerance Code	Packaging Code
<b>FCN</b>	<b>1913</b>	<b>C</b>	<b>124</b>	<b>J</b>	<b>E1</b>
		C = 16 Vdc H = 50 Vdc A = 100 Vdc E = 250 Vdc G = 400 Vdc	124 = 120000 pF = .12 µF	J = 5 % K = 10 %	
<b>FCP</b>	<b>1206</b>	<b>C</b>	<b>393</b>	<b>J</b>	<b>H3</b>
		C = 16 Vdc H = 50 Vdc	393 = 39000 pF = .039 µF	J = 5 % G = 2 %	
<b>FCA</b>	<b>1206</b>	<b>A</b>	<b>105</b>	<b>M</b>	<b>H3</b>
		A = 10 Vdc C = 16 Vdc	105 = 1000000 pF = 1.0 µF	M = 20 %	

(See Reel Quantity Table for an explanation of the Packaging Code)



# Application Guide, Film Chip Capacitors

## Available Surface Mount Film Capacitor Ratings

pF Code	Capacitance			FCN					FCP		FCA	
	pF	nF	μF	16 V	50 V	100 V	250 V	400 V	16 V	50 V	10 V	16 V
101	100	0.1	0.0001									
121	120	0.12	0.00012									
151	150	0.15	0.00015									
181	180	0.18	0.00018									
221	220	0.22	0.00022									
271	270	0.27	0.00027									
331	330	0.33	0.00033									
391	390	0.39	0.00039									
471	470	0.47	0.00047									
561	560	0.56	0.00056						0603	0805		
681	680	0.68	0.00068									
821	820	0.82	0.00082									
102	1000	1	0.001									
122	1200	1.2	0.0012									
152	1500	1.5	0.0015									
182	1800	1.8	0.0018									
222	2200	2.2	0.0022			1206						
272	2700	2.7	0.0027									
332	3300	3.3	0.0033					1913				
392	3900	3.9	0.0039									
472	4700	4.7	0.0047									
562	5600	5.6	0.0056				1913		0805	1206		
682	6800	6.8	0.0068			1210						
822	8200	8.2	0.0082									
103	10000	10	0.01									
123	12000	12	0.012									
153	15000	15	0.015					2416				
183	18000	18	0.018									
223	22000	22	0.022						1206	1210		
273	27000	27	0.027									
333	33000	33	0.033			1913		2420				
393	39000	39	0.039									
473	47000	47	0.047					2820				
563	56000	56	0.056									
683	68000	68	0.068					2825				
823	82000	82	0.082		1913				1210	1913		
104	100000	100	0.1				2420	3925				0805
124	120000	120	0.12			2416						
154	150000	150	0.15	1913	2416			3931				1206
184	180000	180	0.18				2825			2416		
224	220000	220	0.22									1206
274	270000	270	0.27			2820						
334	330000	330	0.33				3925					1206
394	390000	390	0.39	2416								
474	470000	470	0.47			3022	3931					1206
564	560000	560	0.56					6031				
684	680000	680	0.68				3925					1206
824	820000	820	0.82									
105	1000000	1000	1					6040			1206	1210