

### General Description

The MIC2215 is a high performance, triple LDO voltage regulator, with each regulator capable of providing 250mA continuous output current.

Ideal for battery operated applications, the MIC2215 offers 1% initial accuracy, extremely low dropout voltage (100mV@150mA), and low ground current at light load (typically 110 $\mu$ A per regulator). Equipped with a noise bypass pin and featuring very high power supply ripple rejection (PSRR) of up to 80dB, the MIC2215 provides the lowest noise and highest efficiency solution for RF applications in portable electronics such as cellular phones and wireless LAN applications.

Equipped with TTL logic-compatible enable pins, each of the regulators in the MIC2215 can be put into a zero current off mode where the supply current is much less than 1 $\mu$ A when all the regulators are disabled. The MIC2215 is a  $\mu$ Cap design, which enables a stable output with small ceramic output capacitors, reducing both cost and required board space for output bypassing.

The MIC2215 is available in the miniature 16-pin, 4mm  $\times$  4mm MLF™ package.

All support documentation can be found on Micrel's web site at [www.micrel.com](http://www.micrel.com).

### Features

- Input voltage range: +2.25V to +5.5V
- **70dB PSRR**
- Stable with ceramic output capacitor
- High output accuracy:
  - $\pm 1.0\%$  initial accuracy
  - $\pm 2.0\%$  over temperature
- Low dropout voltage of 100mV@150mA
- Low quiescent current: 110 $\mu$ A per regulator
- Fast turn-on time: 30 $\mu$ s
- Zero off-mode current
- Thermal shutdown protection
- Current-limit protection
- Tiny 16-pin (4mm  $\times$  4mm) MLF™ package

### Applications

- Cellular phones
- PCs and peripherals
- Wireless LAN cards
- PDAs
- GPS

### Typical Application

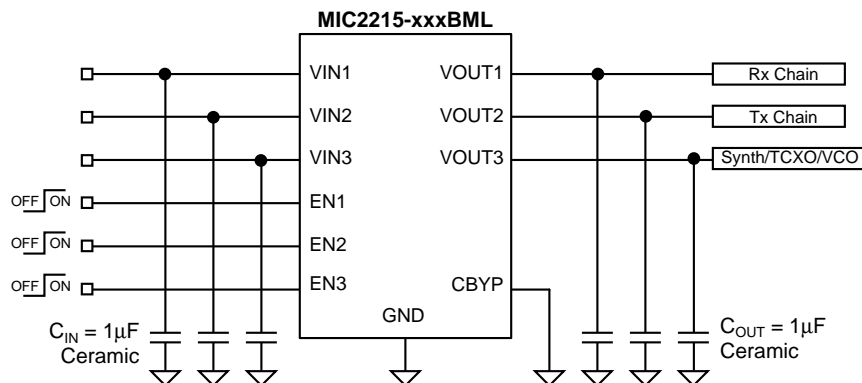

## Ordering Information

Part Number	Voltage <sup>(1)</sup> V <sub>O1</sub> /V <sub>O2</sub> /V <sub>O3</sub>	Junction Temperature Range	Package
MIC2215-PMMBML	3.0V/2.8V/2.8V	-40°C to +125°C	16-Pin MLF™
MIC2215-PPPBML	3.0V/3.0V/3.0V	-40°C to +125°C	16-Pin MLF™
MIC2215-AAABML	Adj./Adj./Adj.	-40°C to +125°C	16-Pin MLF™

**Note:**

1. For other voltage options, contact Micrel, Inc.

Voltage	Code
Adj.	A
1.5	F
1.6	W
1.8	G
1.85	D
1.9	Y
2.0	H
2.1	E
2.5	J
2.6	K
2.65	I
2.7	L
2.8	M
2.85	N
2.9	O
3.0	P
3.1	Q
3.2	R
3.3	S
3.4	T
3.5	U
3.6	V

**Table 1. Voltage Codes**

## Pin Configuration

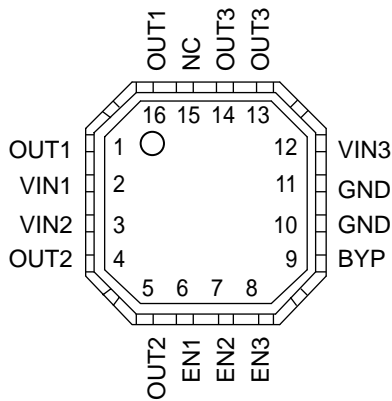

**MIC2215-xxxBML (ML)**  
(Fixed)

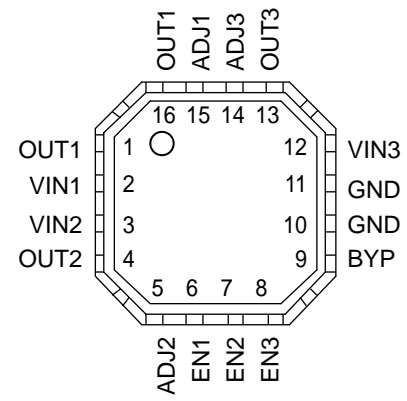

**MIC2215-AAABML (ML)**  
(Adjustable)

## Pin Description

Fixed Output	Adj. Output	Pin Number	Pin Function
VOUT1	VOUT1	1	Output voltage of regulator 1 (250mA). Connect externally to pin 16.
VIN1	VIN1	2	Supply input of regulator 1 (highest input voltage required for common circuitry).
VIN2	VIN2	3	Supply input of regulator 2.
VOUT2	VOUT2	4	Output voltage of regulator 2 (250mA). For fixed output device, connect pins 4 and 5 externally.
VOUT2	—	5	Output voltage of regulator 2 (250mA). For fixed output device, connect pins 4 and 5 externally.
—	ADJ2	5	Adjust Input. Feedback input for regulator 2.
EN1	EN1	6	Enable input to regulator 1. Enables regulator 1 output. Active high input. High = on, low = off.
EN2	EN2	7	Enable input to regulator 2. Enables regulator 2 output. Active high input. High = on, low = off.
EN3	EN3	8	Enable input to regulator 3. Enables regulator 3 output. Active high input. High = on, low = off.
CBYP	CBYP	9	Reference Bypass: Connect external 0.01 $\mu$ F to GND to reduce output noise. May be left open.
GND	GND	10	Ground.
GND	GND	11	Ground.
VIN3	VIN3	12	Supply input of regulator 3.
VOUT3	VOUT3	13	Output voltage of regulator 3 (250mA). For fixed output device, connect pins 13 and 14 externally.
VOUT3	—	14	Output voltage of regulator 3 (250mA). For fixed output device, connect pins 13 and 14 externally.
—	ADJ3	14	Adjust Input. Feedback input for regulator 3.
N/C	—	15	No Connect. Not internally connected.
—	ADJ1	15	Adjust Input. Feedback input for regulator 1.
VOUT1	VOUT1	16	Output voltage of regulator 1 (250mA). Connect externally to pin 1.
GND	GND	Exposed Pad	Ground.

**Absolute Maximum Ratings<sup>(1)</sup>**

Supply Input Voltage ( $V_{IN}$ )	0V to +7V
Enable Input Voltage ( $V_{EN}$ )	0V to +7V
Power Dissipation ( $P_D$ )	Internally Limited <sup>(3)</sup>
Junction Temperature ( $T_J$ )	-40°C to +125°C
Storage Temperature ( $T_S$ )	-65°C to 150°C
Lead Temperature (soldering, 5 sec.)	260°C

**Operating Ratings<sup>(2)</sup>**

Supply Input Voltage ( $V_{IN1}$ )	+2.25V to +5.5V
( $V_{IN2}, V_{IN3}$ )	+2.25V to $V_{IN1}$
Enable Input Voltage ( $V_{EN}$ )	0V to $V_{IN1}$
Junction Temperature ( $T_J$ )	-40°C to +125°C
Package Thermal Resistance MLF™ ( $\theta_{JA}$ )	45°C/W

**Electrical Characteristics<sup>(4)</sup>**

$V_{IN1} = V_{IN2} = V_{IN3} = V_{OUT}$  (highest nominal) +1.0V;  $C_{OUT} = 1.0\mu\text{F}$ ,  $I_{OUT} = 100\mu\text{A}$ ;  $T_J = 25^\circ\text{C}$ , **bold** values indicate -40°C to +125°C; unless noted.

Parameter	Conditions	Min	Typ	Max	Units
Output Voltage Accuracy		-1.0 <b>-2.0</b>		+1.0 <b>+2.0</b>	% %
Output Voltage Temp. Coefficient			40		ppm/C
Line Regulation	$V_{IN} = V_{OUT} + 1\text{V}$ to 5.5V		0.015	<b>0.3</b>	%/V
Load Regulation	$I_{OUT} = 100\mu\text{A}$ to 250mA		0.3	<b>0.5</b>	%
Dropout Voltage	$I_{OUT} = 100\mu\text{A}$		2		mV
	$I_{OUT} = 50\text{mA}$		32		mV
	$I_{OUT} = 100\text{mA}$		63		mV
	$I_{OUT} = 150\text{mA}$		100	<b>150</b>	mV
	$I_{OUT} = 250\text{mA}$		170	<b>275</b>	mV
Ground Current	$I_{OUT1} = I_{OUT2} = I_{OUT3} = 100\mu\text{A}$		280	<b>400</b>	$\mu\text{A}$
	$I_{OUT1} = 100\mu\text{A}$ ; $I_{OUT2}/I_{OUT3} = \text{off}$		110	<b>150</b>	$\mu\text{A}$
	$I_{OUT1} = I_{OUT2} = I_{OUT3} = 250\text{mA}$		420	<b>550</b>	$\mu\text{A}$
Quiescent Current	$V_{EN1} = V_{EN2} = V_{EN3} = 0\text{V}$		0.2	1	$\mu\text{A}$
Ripple Rejection	$V_{IN} = V_{OUT} + 1.0\text{V}$ ; $I_{OUT} = 150\text{mA}$ , $f = 0.1\text{kHz}$ to 1kHz, $C_{BYP} = 0.1\mu\text{F}$		70		dB
	$V_{IN} = V_{OUT} + 0.4\text{V}$ ; $I_{OUT} = 150\text{mA}$ , $f = 0.1\text{kHz}$ to 1kHz, $C_{BYP} = 0.1\mu\text{F}$		60		dB
	$V_{IN} = V_{OUT} + 0.2\text{V}$ ; $I_{OUT} = 150\text{mA}$ , $f = 0.1\text{kHz}$ to 1kHz, $C_{BYP} = 0.1\mu\text{F}$		45		dB
Current Limit	$V_{OUT} = 0\text{V}$ (All regulators)	<b>350</b>	700		mA
Output Voltage Noise	$C_{BYP} = 0.1\mu\text{F}$ , $f = 10\text{Hz}$ to 100kHz		30		$\mu\text{Vrms}$
Turn-On Time	$C_{BYP} = 0.01\mu\text{F}$		30	<b>100</b>	$\mu\text{s}$

**Enable Input**

Enable Input Voltage	Logic Low (Regulator shutdown)			<b>0.4</b>	V
	Logic High (Regulator enabled)	<b>1.5</b>			V
Enable Input Current	$V_{IL} < 0.4\text{V}$ (Regulator shutdown)		1.0		$\mu\text{A}$
	$V_{IH} > 1.5\text{V}$ (Regulator enabled)		0.01		$\mu\text{A}$

**Notes:**

- Exceeding maximum ratings may damage the device.
- The device is not guaranteed to work outside its operating ratings.
- The maximum allowable power dissipation of any  $T_A$  (ambient temperature) is  $P_D(\text{max}) = (T_J(\text{max}) - T_A) \div \theta_{JA}$ . Exceeding the maximum allowable power dissipation will result in excessive die temperature, and the regulator will go into thermal shutdown.
- Specification for packaged product only.

# Typical Characteristics

$T_A = +25^\circ\text{C}$ , unless otherwise noted.

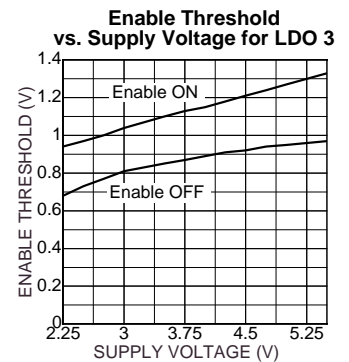
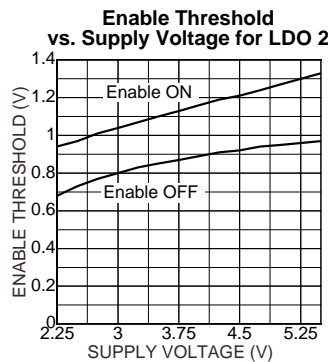
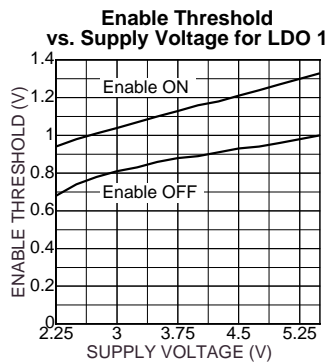
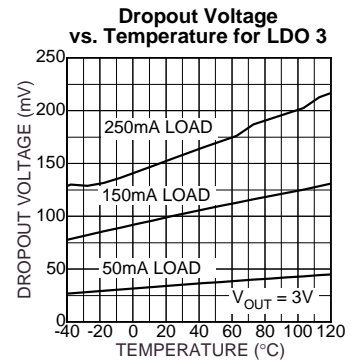
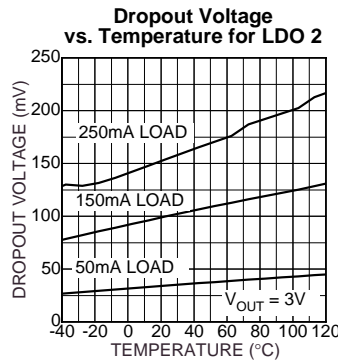
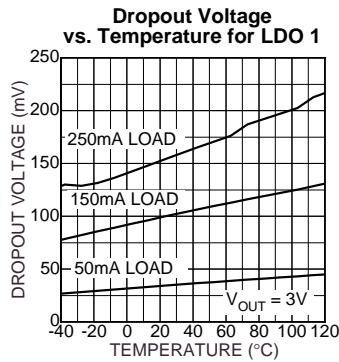
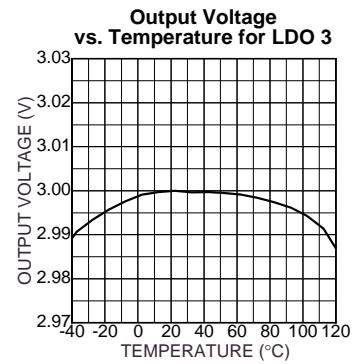
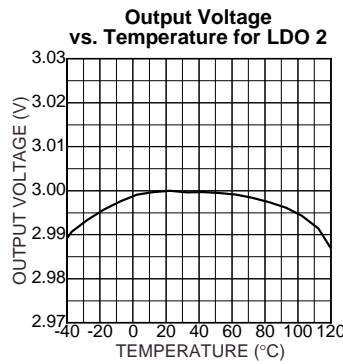
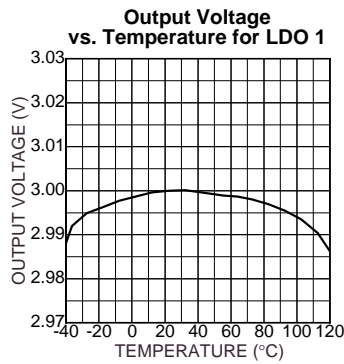
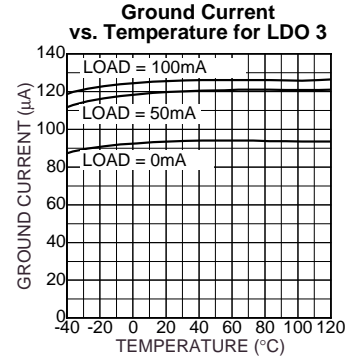
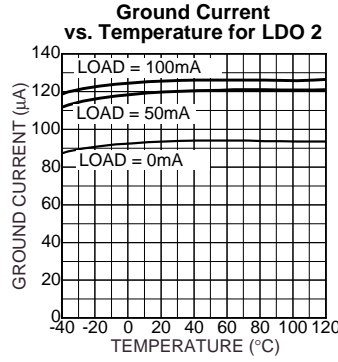
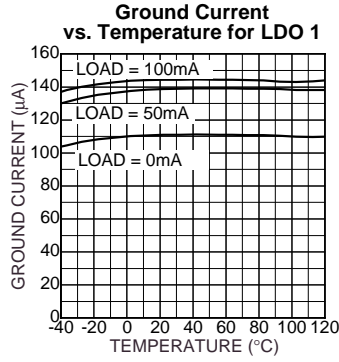

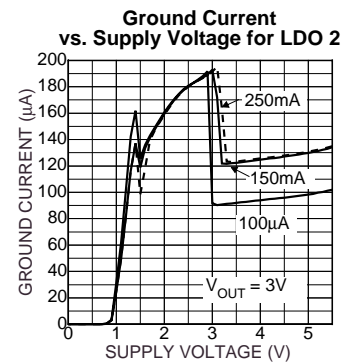
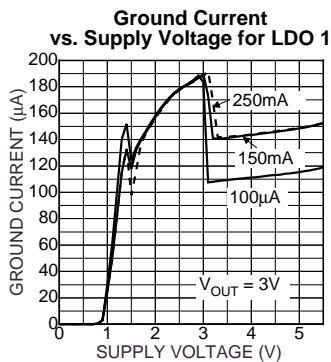
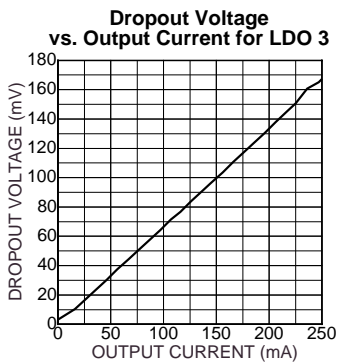
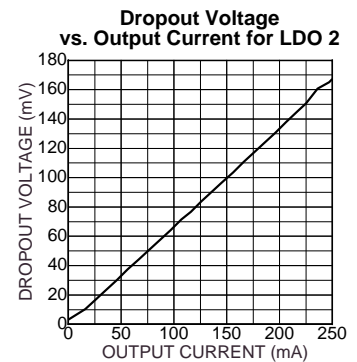
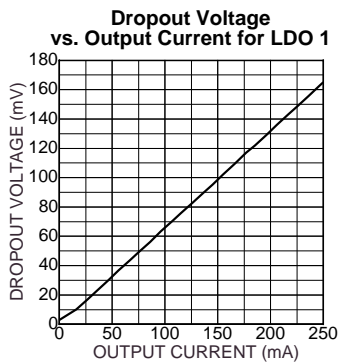
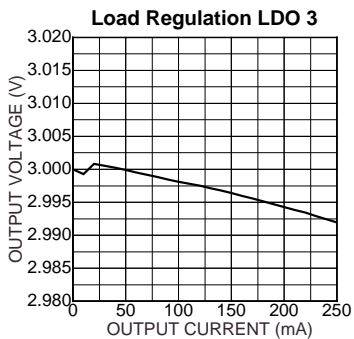
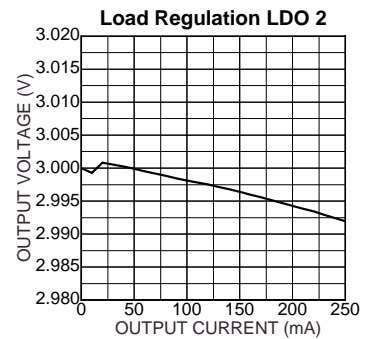
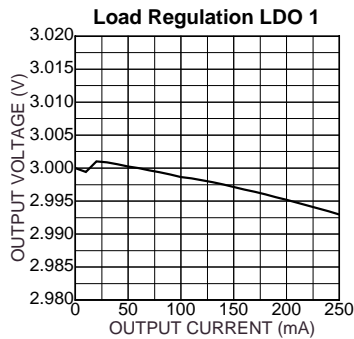
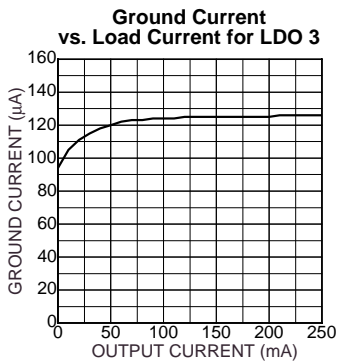
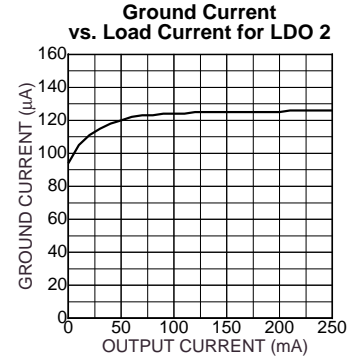
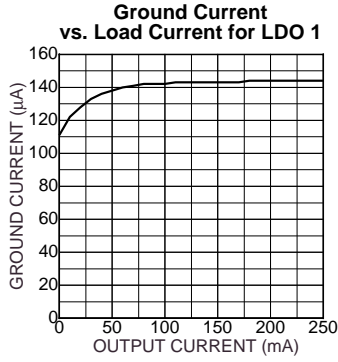
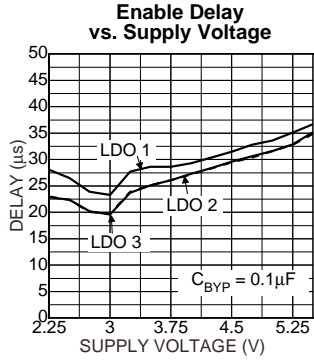

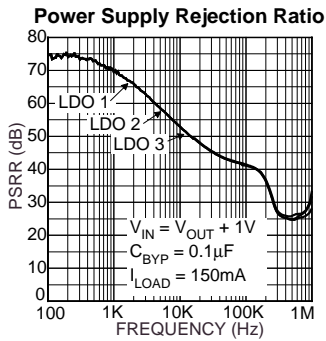
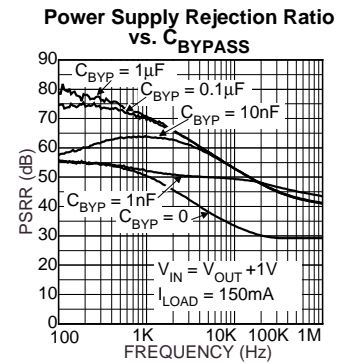
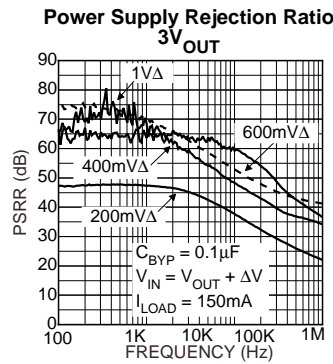
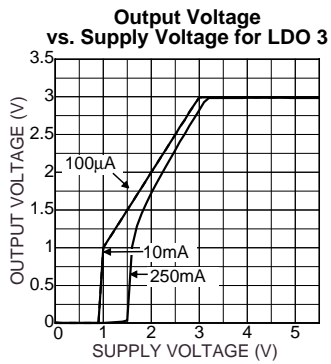
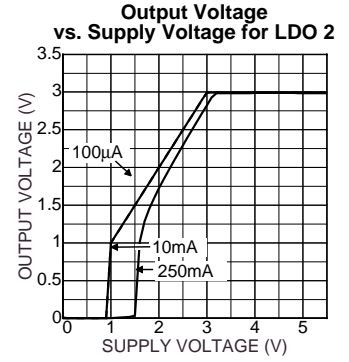
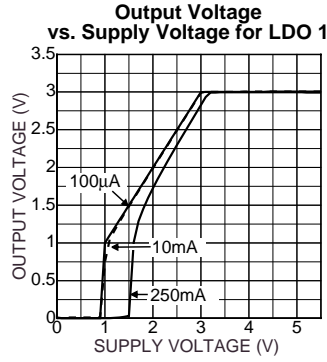
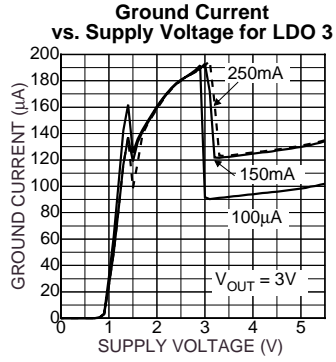

## Functional Diagram

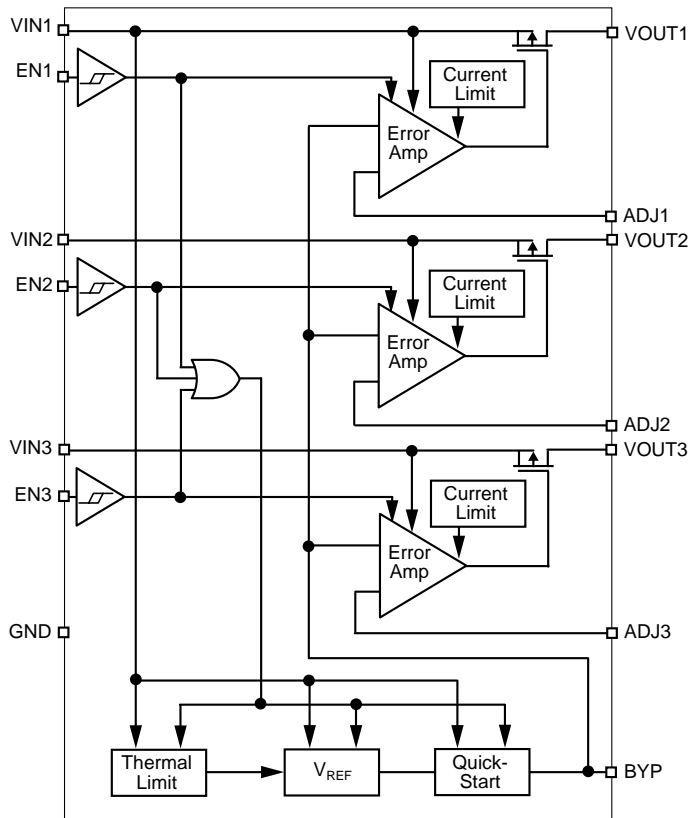

**MIC2215 Block Diagram  
(Adjustable)**

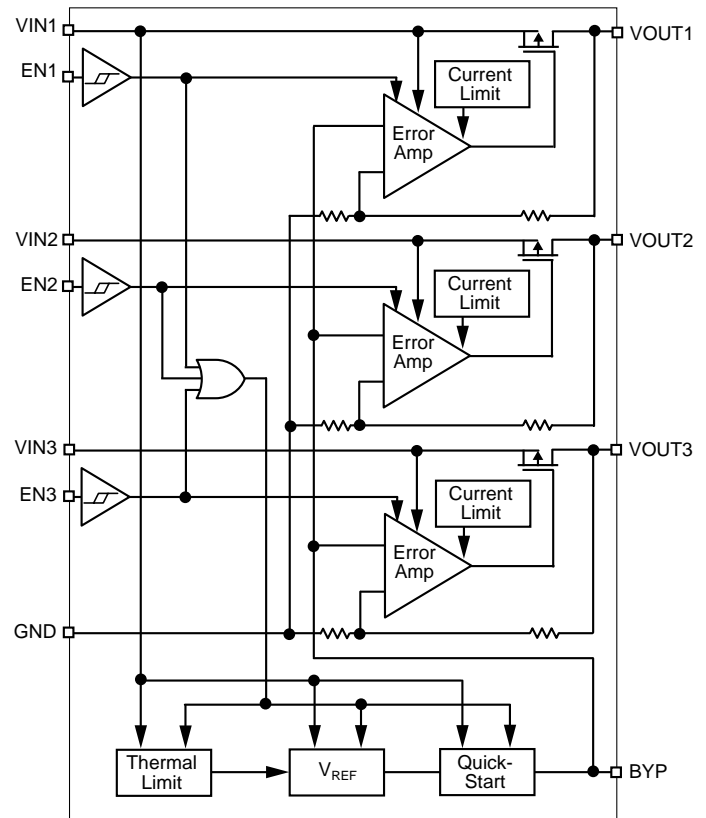

**MIC2215 Block Diagram  
(Fixed)**

## General Description

The MIC2215 is a triple, low noise CMOS LDO. Designed specifically for noise-critical applications in handheld or battery-powered devices, the MIC2215 comes equipped with a noise reduction feature to filter the output noise via an external capacitor. Other features of the MIC2215 include a separate logic compatible enable pin for each channel, current limit, thermal shutdown, and ultra-fast transient response, all within a small MLF™ package.

The MIC2215 is specifically designed to work with low-ESR ceramic capacitors, reducing the amount of board space necessary for power applications, which is critical in handheld wireless devices.



## Applications Information

### Enable/Shutdown

The MIC2215 comes with three active-high enable pins that allow control of each individual regulator to be either disabled or enabled. Forcing the enable pin low disables the respective regulator and sends it into a “zero” off-mode-current state. In this state, current consumed by the individual regulator goes nearly to zero. This is true for both regulators 2 and 3. Regulator 1’s input supply pin is also used to power the internal reference. When any regulator, either 1, 2, or 3 is enabled, an additional 20 $\mu$ A for the reference will be drawn through  $V_{IN1}$ . All three must be disabled to enter the “zero” current-off-mode-state. Forcing the enable pin high enables each respective output voltage. This part is CMOS and none of the enable pins can be left floating; a floating enable pin may cause an indeterminate state on the output.

### Input Capacitor

The MIC2215 is a high performance, high bandwidth device. Therefore, it requires a well-bypassed input supply for optimal performance. A small 0.1 $\mu$ F capacitor placed close to the input is recommended to aid in noise performance. Low-ESR ceramic capacitors provide optimal performance at a minimum of space. Additional high-frequency capacitors such as small valued NPO dielectric type capacitors help to filter out high frequency noise and are good practice in any RF-based circuit.

### Output Capacitor

The MIC2215 requires an output capacitor for stability. The design requires 1 $\mu$ F or greater on the output to maintain stability. The design is optimized for use with low-ESR ceramic chip capacitors. X7R/X5R dielectric-type ceramic capacitors are recommended because of their temperature performance. X7R-type capacitors change capacitance by 15% over their operating temperature range and are the most stable type of ceramic capacitors. Z5U and Y5V dielectric capacitors change value by as much as 50% and 60%, respectively, over their operating temperature ranges. To use a ceramic chip capacitor with Y5V dielectric, the value must be much higher than an X7R ceramic capacitor to ensure the same minimum capacitance over the equivalent operating temperature range.

### Bypass Pin

A capacitor can be placed from the noise bypass pin to ground to reduce output voltage noise. The capacitor bypasses the internal reference. There is one single internal reference shared by each output, therefore the bypassing affects each regulator. A 0.1 $\mu$ F capacitor is recommended for applications that require low-noise outputs. The bypass capacitor can be increased, further reducing noise and improving PSRR. Turn-on time increases slightly with respect to bypass capacitance.

### Internal Reference

The internal bandgap, or reference, is powered from the  $V_{IN1}$  input. Due to some of the input noise (PSRR) contributions being imposed on the bandgap, it is important to make  $V_{IN1}$  as clean as possible with good bypassing close to the input.

### Multiple Input Supplies

The MIC2215 can be used with multiple input supplies when desired. The only requirement, aside from maintaining the voltages within the operating ranges, is that  $V_{IN1}$  always remains the highest voltage potential.

### No-Load Stability

The MIC2215 will remain stable and in regulation with no load, unlike many other voltage regulators. This is especially important in CMOS RAM keep-alive applications.

### Thermal Considerations

The MIC2215 is designed to provide up to 250mA of current per channel in a very small package. Maximum power dissipation can be calculated based on the output current and the voltage drop across the part. To determine the maximum power dissipation of the package, use the junction-to-ambient thermal resistance of the device and the following basic equation:

$$P_D (\text{max}) = (T_J (\text{max}) - T_A) \div \theta_{JA}$$

$T_J (\text{max})$  is the maximum junction temperature of the die, 125°C, and  $T_A$  is the ambient operating temperature.  $\theta_{JA}$  is layout dependent; Table 2 shows examples of the junction-to-ambient thermal resistance for the MIC2215.

Package	$\theta_{JA}$ Recommended Minimum Footprint
16-Pin MLF™	43°C/W

**Table 2. MLF™ Thermal Resistance**

The actual power dissipation of the regulator circuit can be determined using the equation:

$$P_{DTOTAL} = P_{DLDO1} + P_{DLDO2} + P_{DLDO3}$$

$$P_{DLDO1} = (V_{IN1} - V_{OUT1}) \times I_{OUT1}$$

$$P_{DLDO2} = (V_{IN2} - V_{OUT2}) \times I_{OUT2}$$

$$P_{DLDO3} = (V_{IN3} - V_{OUT3}) \times I_{OUT3}$$

Substituting  $P_D (\text{max})$  for  $P_D$  and solving for the operating conditions that are critical to the application will give the maximum operating conditions for the regulator circuit. For example, when operating the MIC2215 at 60°C with a minimum footprint layout, the maximum load currents can be calculated as follows:

$$P_D (\text{max}) = (125^\circ\text{C} - 60^\circ\text{C})/43^\circ\text{C/W}$$

$$P_D (\text{max}) = 1.511\text{W}$$

The junction-to-ambient thermal resistance for the minimum footprint is 43°C/W, from Table 2. The maximum power dissipation must not be exceeded for proper operation. Using a lithium-ion battery as the supply voltage, 2.8V/250mA for channel 1, 3V/100mA for channel 2 and 2.8V/50mA for channel 3, maximum power can be calculated as follows:

$$P_{DLDO1} = (V_{IN1} - V_{OUT1}) \times I_{OUT1}$$

$$P_{DLDO1} = (4.2\text{V} - 2.8\text{V}) \times 250\text{mA}$$

$$P_{DLDO1} = 350\text{mW}$$

$$P_{DLDO2} = (V_{IN2} - V_{OUT2}) \times I_{OUT2}$$

$$P_{DLDO2} = (4.2V - 3.0V) \times 100mA$$

$$P_{DLDO2} = 120mW$$

$$P_{DLDO3} = (V_{IN3} - V_{OUT3}) \times I_{OUT3}$$

$$P_{DLDO3} = (4.2V - 2.8V) \times 50mA$$

$$P_{DLDO3} = 70mW$$

$$P_{DTOTAL} = P_{DLDO1} + P_{DLDO2} + P_{DLDO3}$$

$$P_{DTOTAL} = 350mW + 120mW + 70mW$$

$$P_{DTOTAL} = 540mW$$

The calculation shows that we are well below the maximum allowable power dissipation of 1.511W for a 60°C ambient temperature. After the maximum power dissipation has been calculated, it is always a good idea to calculate the maximum ambient temperature for a 125°C junction temperature. Calculating maximum ambient temperature as follows:

$$T_A (\text{max}) = T_J (\text{max}) - (P_D \times \theta_{JA})$$

$$T_A (\text{max}) = 125^\circ\text{C} - (540mW \times 43^\circ\text{C/W})$$

$$T_A (\text{max}) = 101^\circ\text{C}$$

For more information, please refer to the *Designing with Low-Dropout Voltage Regulators Handbook*.

### Adjustable Regulator Application

Adjustable regulators use the ratio of two resistors to multiply the reference voltage to produce the desired output voltage. The MIC2215 can be adjusted from 1.25V to (5.5V – max  $V_{DROPOUT}$ ) by using two external resistors (Figure 1). The resistors set the output voltage based on the following equation:

$$V_{OUT} = V_{REF} \left( 1 + \frac{R1}{R2} \right)$$

$$V_{REF} = 1.25V$$

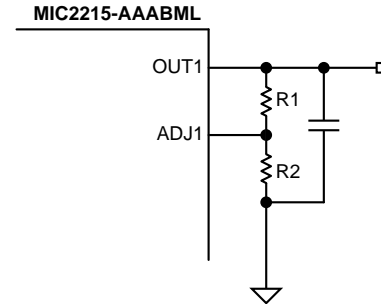
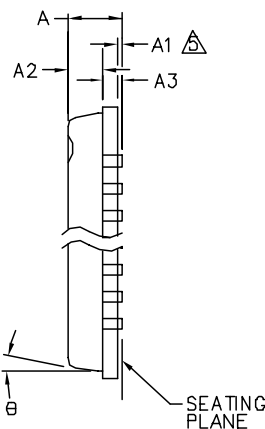
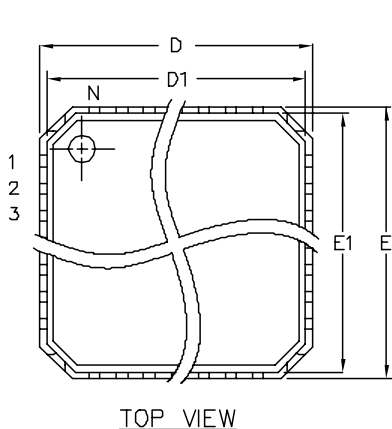
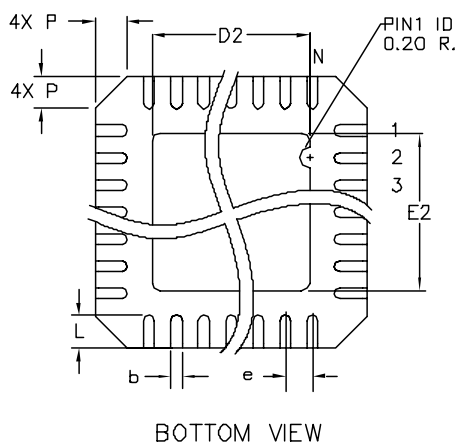

Figure 1. Adjustable Output

# Package Information



	DIMENSION (mm)		
	MIN.	NOM.	MAX.
A	-	0.85	1.00
A1	0.00	0.01	0.05
A2	-	0.65	0.80
A3	0.20 REF.		
D	4.00 BSC		
D1	3.75 BSC		
D2	2.19	2.34	2.49
E	4.00 BSC		
E1	3.75 BSC		
E2	2.19	2.34	2.49
θ	12°		
P	0.24	0.42	0.60
e	0.65 BSC		
N	16		
L	0.50	0.60	0.75
b	0.23	0.28	0.35



- NOTE:
1. ALL DIMENSIONS ARE IN MILLIMETERS.
  2. N IS THE NUMBER OF TERMINALS. THE NUMBER OF TERMINALS PER SIDE IS N/4.
  3. THE PIN#1 IDENTIFIRE MUST BE EXISTED ON THE TOP SURFACE OF PACKAGE BY USING IDENTIFICATION MARK OR OTHER FEATURE OF PACKAGE BODY.
  4. PACKAGE WARPAGE MAX 0.05mm.
- △ APPLIED FOR EXPOSED PAD AND TERMINALS.

## 16-Pin (4mm x 4mm) MLF™ (ML)

**MICREL, INC. 1849 FORTUNE DRIVE SAN JOSE, CA 95131 USA**

TEL + 1 (408) 944-0800 FAX + 1 (408) 474-1000 WEB <http://www.micrel.com>

The information furnished by Micrel in this data sheet is believed to be accurate and reliable. However, no responsibility is assumed by Micrel for its use. Micrel reserves the right to change circuitry and specifications at any time without notification to the customer.

Micrel Products are not designed or authorized for use as components in life support appliances, devices or systems where malfunction of a product can reasonably be expected to result in personal injury. Life support devices or systems are devices or systems that (a) are intended for surgical implant into the body or (b) support or sustain life, and whose failure to perform can be reasonably expected to result in a significant injury to the user. A Purchaser's use or sale of Micrel Products for use in life support appliances, devices or systems is at Purchaser's own risk and Purchaser agrees to fully indemnify Micrel for any damages resulting from such use or sale.

© 2004 Micrel, Incorporated.