

CD players, CD-ROM laser diode

RLD78MYA1

Though it is an open type package, by using a metal cap, pressing structure correspondence and protection of a laser element are enabled, and reliability is secured.

●Applications

Compact disc players
CD-ROM

●Features

- 1) $\phi 5.6$ metal shell type open package.
- 2) A laser element is protected by using a metal cap.
- 3) Interchangeability reservation with $\phi 5.6$ metal package of an industry standard.

●External dimensions (Units : mm)

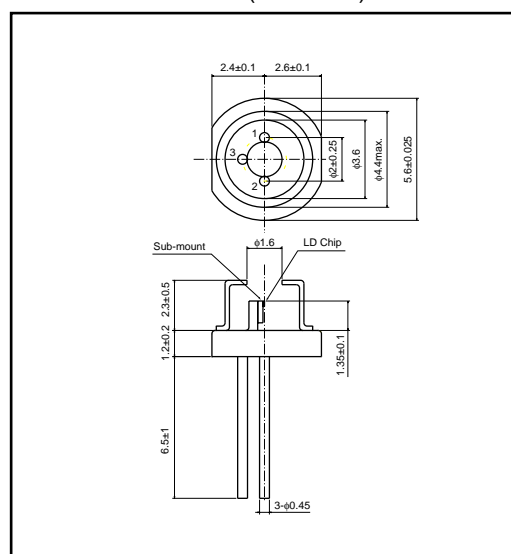

●Absolute maximum ratings (Tc=25°C)

Parameter	Symbol	Limits	Unit	
Output	P _O	5	mW	
Reverse voltage	Laser	V _R	2	V
	PIN photodiode	V _{R (PIN)}	30	V
Operating temperature	T _{opr}	-10 to +70	°C	
Storage temperature	T _{stg}	-40 to +85	°C	

Laser diodes

●Electrical and optical characteristics (Tc=25°C)

Parameter	Symbol	Min.	Typ.	Max.	Unit	Conditions
Threshold current	I _{th}	–	35	60	mA	–
Operating current	I _{op}	–	45	70	mA	P _o =3mW
Operating voltage	V _{op}	–	1.9	2.3	V	P _o =3mW
Differential efficiency	η	0.1	0.25	0.6	mW/mA	$\frac{2mW}{I(3mW)-I(1mW)}$
Monitor current	I _m	0.05	0.15	0.3	mA	P _o =3mW, V _{R(PIN)} =15V
Parallel divergence angle	θ _∥ *	8	11	15	deg	P _o =3mW
Perpendicular divergence angle	θ _⊥ *	20	37	45	deg	
Parallel deviation angle	Δφ _∥	–	–	±2	deg	
Perpendicular deviation angle	Δφ _⊥	–	–	±3	deg	
Emission point accuracy	ΔX	–	–	±100	μm	–
	ΔY					
	ΔZ					
Peak emission wavelength	λ	770	785	810	nm	P _o =3mW
Signal-to-noise ratio	S / N	60	–	–	dB	f=720kHz, Δf=10kHz

*θ_∥ and θ_⊥ are defined as the angle within which the intensity is 50% of the peak value.

●Electrical and optical characteristic curves

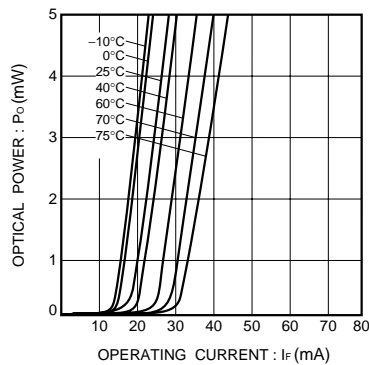

Fig.1 Optical output vs.operating current

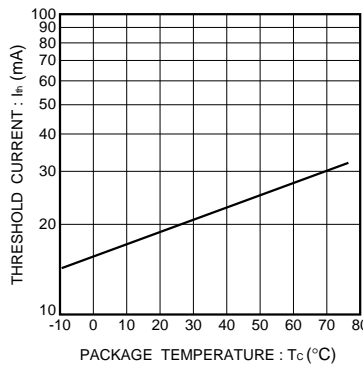

Fig.2 Dependence of threshold current on temperature

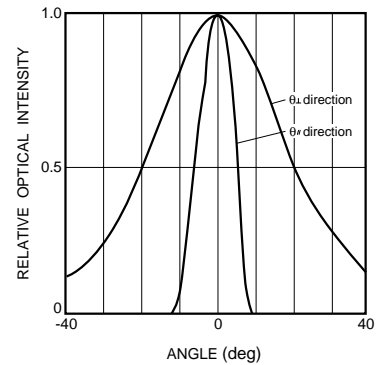

Fig.3 Far field pattern

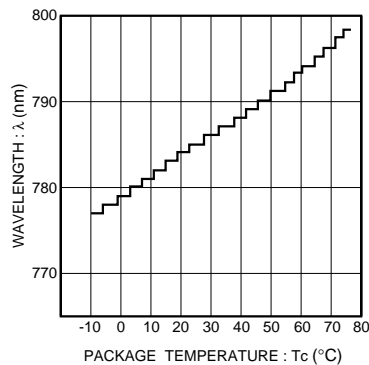

Fig.4 Dependence of wavelength on temperature

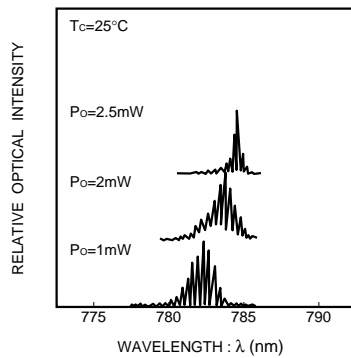

Fig.5 Dependence of emission spectrum on optical output

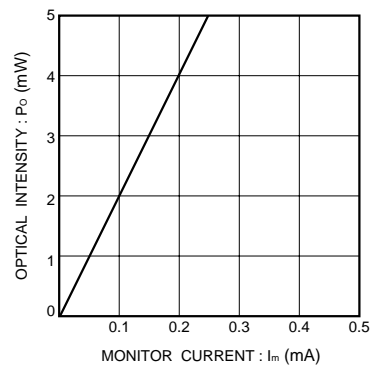

Fig.6 Monitor current vs.optical output

Laser diodes

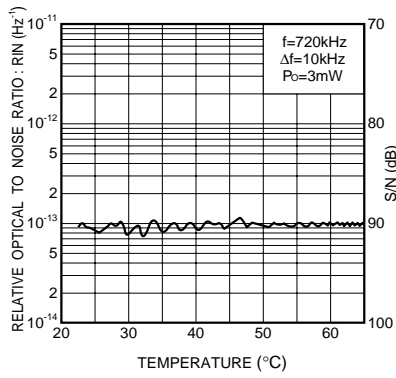

Fig.7 Temperature dependence of noise

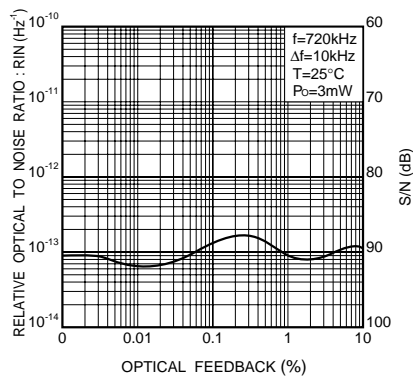

Fig.8 Dependence of noise on optical feedback

This datasheet has been download from:

www.datasheetcatalog.com

Datasheets for electronics components.