

LPC IO with 8042 KBC, Reset Generation, HWM and Multiple Serial Ports

PRODUCT FEATURES

Datasheet

- **General Features**
 - 3.3 Volt Operation (SIO Block is 5 Volt Tolerant)
 - Low Pin Count Bus (LPC) Interface
 - Programmable Wake-up Event (PME) Interface
 - PC99, PC2001 Compliant
 - ACPI 2.0 Compliant
 - Serial IRQ Interface Compatible with Serialized IRQ Support for PCI Systems
 - ISA Plug-and-Play Compatible Register Set
 - Four Address Options for Power On Configuration Port
 - System Management Interrupt (SMI)
 - 40 General Purpose I/O pins
 - 6 GPIO with VID compatible inputs
 - Support for power button on PS/2 Keyboard
 - Security Key Register (32 byte) for Device Authentication
- **Watchdog Timer**
- **Resume and Main Power Good Generator**
- **Programmable Clock Output to 16 HZ.**
- **2.88MB Super I/O Floppy Disk Controller**
 - Licensed CMOS 765B Floppy Disk Controller
 - Supports Two Floppy Drives
 - Configurable Open Drain/Push-Pull
 - Supports Vertical Recording Format
 - 16-Byte Data FIFO
 - 100% IBM® Compatibility
 - Detects All Overrun and Underrun Conditions
 - Sophisticated Power Control Circuitry (PCC) Including Multiple Powerdown Modes for Reduced Power Consumption
 - DMA Enable Logic
 - Data Rate and Drive Control Registers
 - 480 Address, Up to Eight IRQ and Four DMA Options
 - Support FDD Interface on Parallel Port Pins
- **Enhanced Digital Data Separator**
 - 2 Mbps, 1 Mbps, 500 Kbps, 300 Kbps, 250 Kbp Data Rates
 - Programmable Precompensation Modes
- **Keyboard Controller**
 - 8042 Software Compatible
 - 8 Bit Microcomputer
 - 2k Bytes of Program ROM
 - 256 Bytes of Data RAM
 - Four Open Drain Outputs Dedicated for Keyboard/Mouse Interface
 - Asynchronous Access to Two Data Registers and One Status Register
 - Supports Interrupt and Polling Access
 - 8 Bit Counter Timer
- Port 92 Support
- Fast Gate A20 and KRESET Outputs
- Phoenix Keyboard BIOS ROM
- **Multiple Serial Ports**
 - SCH3112 - 2 Full Function Serial Ports
 - SCH3114 - 4 Full Function Serial Ports
 - SCH3116 - 4 Full Function and 2 Four-Pin Serial Ports
 - High Speed NS16C550A Compatible UARTs with Send/Receive 16-Byte FIFOs
 - Supports 230k, 460k, 921k and 1.5M Baud
 - Programmable Baud Rate Generator
 - Modem Control Circuitry
 - 480 Address and 15 IRQ Options
 - Support IRQ Sharing among serial ports
 - RS485 Auto Direction Control Mode
- **Infrared Port**
 - Multiprotocol Infrared Interface
 - IrDA 1.0 Compliant
 - SHARP ASK IR
 - 480 Addresses, Up to 15 IRQ
- **Multi-Mode™ Parallel Port with ChiProtect™**
 - Standard Mode IBM PC/XT®, PC/AT®, and PS/2™ Compatible Bi-directional Parallel Port
 - Enhanced Parallel Port (EPP) Compatible - EPP 1.7 and EPP 1.9 (IEEE 1284 Compliant)
 - IEEE 1284 Compliant Enhanced Capabilities Port (ECP)
 - ChiProtect Circuitry for Protection
 - 960 Address, Up to 15 IRQ and Four DMA Options
- **Hardware Monitor**
 - Monitor Power supplies (+2.5V, +5V, +12V, V_{ccp} (processor voltage), V_{CC}, V_{bat} and V_{tr})
 - Remote Thermal Diode Sensing for Two External Temperature Measurements accurate to 1.5°C
 - Internal Ambient Temperature Measurement
 - Limit Comparison of all Monitored Values
 - Programmable Automatic FAN control based on temperature
 - nHWM_INT Pin for out-of-limit Temperature or Voltage Indication
 - Configurable offset for internal or external temperature channels
 - Thermtrip signal for over temperature indication
- **IDE Reset Output and 3 PCI Reset Buffers with Software Control Capability (SCH3112 and SCH3114 Only)**
- **Power Button Control and AC Power Failure Recovery (SCH3112 and SCH3114 Only)**
- **Industrial (+85°C to -40°C) Temperature Range**
- **128 Pin VTQFP Package**

ORDER NUMBER(S):

SCH3112I-NE FOR 128 PIN, VTQFP PACKAGE (INDUSTRIAL TEMPERATURE RANGE)

SCH3114I-NE FOR 128 PIN, VTQFP PACKAGE (INDUSTRIAL TEMPERATURE RANGE)

SCH3116I-NE FOR 128 PIN, VTQFP PACKAGE (INDUSTRIAL TEMPERATURE RANGE)

SCH3112I-NU FOR 128 PIN, VTQFP PACKAGE (LEAD-FREE, INDUSTRIAL TEMPERATURE RANGE)

SCH3114I-NU FOR 128 PIN, VTQFP PACKAGE (LEAD-FREE, INDUSTRIAL TEMPERATURE RANGE)

SCH3116I-NU FOR 128 PIN, VTQFP PACKAGE (LEAD-FREE, INDUSTRIAL TEMPERATURE RANGE)



80 Arkay Drive
Hauppauge, NY 11788
(631) 435-6000
FAX (631) 273-3123

Copyright © SMSC 2004. All rights reserved.

Circuit diagrams and other information relating to SMSC products are included as a means of illustrating typical applications. Consequently, complete information sufficient for construction purposes is not necessarily given. Although the information has been checked and is believed to be accurate, no responsibility is assumed for inaccuracies. SMSC reserves the right to make changes to specifications and product descriptions at any time without notice. Contact your local SMSC sales office to obtain the latest specifications before placing your product order. The provision of this information does not convey to the purchaser of the described semiconductor devices any licenses under any patent rights or other intellectual property rights of SMSC or others. All sales are expressly conditional on your agreement to the terms and conditions of the most recently dated version of SMSC's standard Terms of Sale Agreement dated before the date of your order (the "Terms of Sale Agreement"). The product may contain design defects or errors known as anomalies which may cause the product's functions to deviate from published specifications. Anomaly sheets are available upon request. SMSC products are not designed, intended, authorized or warranted for use in any life support or other application where product failure could cause or contribute to personal injury or severe property damage. Any and all such uses without prior written approval of an Officer of SMSC and further testing and/or modification will be fully at the risk of the customer. Copies of this document or other SMSC literature, as well as the Terms of Sale Agreement, may be obtained by visiting SMSC's website at <http://www.smisc.com>. SMSC is a registered trademark of Standard Microsystems Corporation ("SMSC"). Product names and company names are the trademarks of their respective holders.

SMSC DISCLAIMS AND EXCLUDES ANY AND ALL WARRANTIES, INCLUDING WITHOUT LIMITATION ANY AND ALL IMPLIED WARRANTIES OF MERCHANTABILITY, FITNESS FOR A PARTICULAR PURPOSE, TITLE, AND AGAINST INFRINGEMENT AND THE LIKE, AND ANY AND ALL WARRANTIES ARISING FROM ANY COURSE OF DEALING OR USAGE OF TRADE.

IN NO EVENT SHALL SMSC BE LIABLE FOR ANY DIRECT, INCIDENTAL, INDIRECT, SPECIAL, PUNITIVE, OR CONSEQUENTIAL DAMAGES; OR FOR LOST DATA, PROFITS, SAVINGS OR REVENUES OF ANY KIND; REGARDLESS OF THE FORM OF ACTION, WHETHER BASED ON CONTRACT; TORT; NEGLIGENCE OF SMSC OR OTHERS; STRICT LIABILITY; BREACH OF WARRANTY; OR OTHERWISE; WHETHER OR NOT ANY REMEDY OF BUYER IS HELD TO HAVE FAILED OF ITS ESSENTIAL PURPOSE, AND WHETHER OR NOT SMSC HAS BEEN ADVISED OF THE POSSIBILITY OF SUCH DAMAGES.

Datasheet

0.1 Reference Documents

1. *Intel Low Pin Count Specification, Revision 1.0*, September 29, 1997
2. *PCI Local Bus Specification, Revision 2.2*, December 18, 1998
3. *Advanced Configuration and Power Interface Specification, Revision 1.0b*, February 2, 1999
4. IEEE 1284 Extended Capabilities Port Protocol and ISA Standard, Rev. 1.14, July 14, 1993.
5. Hardware Description of the 8042, Intel 8 bit Embedded Controller Handbook.
6. SMSC Application Note (AN 8-8) "Keyboard and Mouse Wakeup Functionality", dated 03/23/02.



Table of Contents

0.1	Reference Documents	iii
<hr/>		
Chapter 1	General Description	1
<hr/>		
Chapter 2	Pinout	3
2.1	SCH311X Pinout Summary	4
2.2	Pin Functions	9
2.3	Buffer Description	21
<hr/>		
Chapter 3	Block Diagram	23
<hr/>		
Chapter 4	Power Functionality	25
4.1	VCC Power	25
4.2	HVTR Power	25
4.3	3 Volt Operation / 5 Volt Tolerance	25
4.4	VTR Support	25
4.4.1	Trickle Power Functionality	26
4.5	Vbat Support	27
4.6	32.768 KHz Trickle Clock Input	27
4.7	Super I/O Functions	28
4.8	Power Management Events (PME/SCI)	28
<hr/>		
Chapter 5	SIO Overview	29
5.1	Super I/O Registers	29
5.2	Host Processor Interface (LPC)	29
<hr/>		
Chapter 6	LPC Interface	31
6.1	LPC Interface Signal Definition	31
6.1.1	LPC Required Signals	31
6.1.2	LPC Optional Signals	31
6.2	Supported LPC Cycles	31
6.3	Device Specific Information	32
6.3.1	SYNC Protocol	32
6.3.2	Reset Policy	33
<hr/>		
Chapter 7	Floppy Disk Controller	35
7.1	FDC Internal Registers	35
7.1.1	Status Register A (SRA)	35
7.1.2	PS/2 Model 30 Mode	36
7.1.3	Status Register Encoding	47
7.1.4	Instruction Set	55
7.1.5	Data Transfer Commands	64
<hr/>		
Chapter 8	Serial Port (UART)	77
8.1	Infrared Interface	92
8.1.1	IR Transmit Pin	93
8.2	Interrupt Sharing	93
8.3	RS485 Auto Direction Control	95
8.4	Reduced Pin Serial Ports (SCH3116 Only)	97
<hr/>		
Chapter 9	Parallel Port	101
9.1	IBM XT/AT Compatible, Bi-Directional and EPP Modes	102

9.2	Extended Capabilities Parallel Port	108
9.3	Parallel Port Floppy Disk Controller	120
9.3.1	Buffer Types	121
9.3.2	FDC/PP Control Bits	122
<hr/>		
Chapter 10 Power Management		123
<hr/>		
Chapter 11 Serial IRQ		125
<hr/>		
Chapter 12 8042 Keyboard Controller Description		129
12.1	Keyboard Interface	129
12.2	External Keyboard and Mouse Interface	131
12.2.1	Keyboard/Mouse Swap Bit	131
12.3	Keyboard Power Management	131
12.4	Interrupts	132
12.5	Memory Configurations	132
12.6	Register Definitions	132
12.7	External Clock Signal	133
12.8	Default Reset Conditions	133
12.9	Keyboard and Mouse PME Generation	136
<hr/>		
Chapter 13 General Purpose I/O (GPIO)		139
13.1	GPIO Pins	139
13.2	Description	141
13.3	GPIO Control	148
13.4	GPIO Operation	148
13.5	GPIO PME and SMI Functionality	149
13.6	Either Edge Triggered Interrupts	150
13.7	LED Functionality	150
<hr/>		
Chapter 14 System Management Interrupt (SMI)		151
<hr/>		
Chapter 15 PME Support		153
15.1	PME Events	153
15.2	Enabling SMI Events onto the PME Pin	155
15.3	PME Function Pin Control	155
15.4	Wake on Specific Key Code	155
15.5	Wake on Specific Mouse Click	156
<hr/>		
Chapter 16 Watchdog Timer		159
<hr/>		
Chapter 17 Programmable Clock Output		161
<hr/>		
Chapter 18 Reset Generation		163
18.1	Watchdog Timer for Reset Generation	164
18.2	PWRGD_OUT Timing	165
18.3	Power Supply Voltage Scaling and Tolerances	165
<hr/>		
Chapter 19 Buffered PCI Outputs		167
19.1	Buffered PCI Outputs Interface	167
19.1.1	IDE Reset Output	167
19.1.2	nPCIRSTx Output Logic	168
<hr/>		
Chapter 20 Power Control Features		169

Datasheet

20.1	nIO_PME Pin use in Power Control	171
20.2	Front Panel Reset	171
20.3	A/C Power Failure Recovery Control (SCH3112 and SCH3114 Devices only)	172
20.3.1	PB_OUT# and PS_ON#	173
20.3.2	Power Supply Timing Diagrams	174
20.4	Resume Reset Signal Generation	175
20.5	Keyboard Power Button	175
20.5.1	Keyboard Data Format	175
20.5.2	System for Decoding Scan Code Make Bytes Received from the Keyboard	177
20.5.3	System for Decoding Scan Code Break Bytes Received from the Keyboard	178
20.6	Wake on Specific Mouse Event	181

Chapter 21 Low Battery Detection Logic 183

21.1	VBAT POR	183
21.2	Low Battery	183
21.2.1	Under Battery Power	183
21.2.2	Under VTR Power	184
21.2.3	Under VCC Power	184

Chapter 22 Battery Backed Security Key Register 185**Chapter 23 Temperature Monitoring and Fan Control** 187

23.1	Block Diagram	187
23.2	HWM Interface	187
23.3	Power Supply	188
23.4	Resetting the SCH311X Hardware Monitor Block	188
23.4.1	VTR Power-On Reset	188
23.4.2	VCC Power-On Reset	188
23.4.3	Soft Reset (Initialization)	189
23.5	Clocks	189
23.6	Input Monitoring	189
23.7	Monitoring Modes	189
23.7.1	Continuous Monitoring Mode	190
23.7.2	Cycle Monitoring Mode	191
23.8	Interrupt Status Registers	191
23.8.1	Interrupt Enable Bits	192
23.8.2	Diode Fault	194
23.9	Interrupt Signal	194
23.9.1	Interrupt Pin (nHWM_INT)	195
23.9.2	Interrupt as a PME Event	195
23.9.3	Interrupt as an SMI Event	195
23.9.4	Interrupt Event on Serial IRQ	196
23.10	Low Power Mode	196
23.11	Temperature Measurement	196
23.11.1	Internal Temperature Measurement	196
23.11.2	External Temperature Measurement	196
23.11.3	Temperature Data Format	197
23.11.4	Offset Registers	198
23.12	Thermal Zones	198
23.13	Fan Control	198
23.13.1	Limit and Configuration Registers	198
23.13.2	Device Set-Up	199
23.13.3	PWM Fan Speed Control	200
23.13.4	Operation of PWM Pin Following a Power Cycle	207
23.13.5	Active Minimum Temperature Adjustment (AMTA)	213

23.14	nTHERMTRIP	216
23.14.1	nTHERMTRIP Operation	216
23.14.2	Fan Speed Monitoring	217
23.14.3	Locked Rotor Support for Tachometer Inputs	223
23.14.4	Linking Fan Tachometers to PWMs.	223
23.15	High Frequency PWM Options	223
23.15.1	PWM Frequencies Supported	223

Chapter 24 Hardware Monitoring Register Set 225

24.1	Undefined Registers	229
24.2	Defined Registers	230
24.2.1	Register 10h: SMSC Test Register	230
24.2.2	Register 1Dh, 1Eh, 1Fh: Offset Registers	230
24.2.3	Registers 20-24h, 99-9Ah: Voltage Reading	230
24.2.4	Registers 25-27h: Temperature Reading	231
24.2.5	Registers 28-2Dh: Fan Tachometer Reading	232
24.2.6	Registers 30-32h: Current PWM Duty	233
24.2.7	Register 3Dh: Device ID	234
24.2.8	Register 3Eh: Company ID	234
24.2.9	Register 3Fh: Revision	234
24.2.10	Register 40h: Ready/Lock/Start Monitoring	235
24.2.11	Register 41h: Interrupt Status Register 1	236
24.2.12	Register 42h: Interrupt Status Register 2	238
24.2.13	Registers 44-4Dh, 9B-9Eh: Voltage Limit Registers	239
24.2.14	Registers 4E-53h: Temperature Limit Registers	241
24.2.15	Registers 54-59h: Fan Tachometer Low Limit.	242
24.2.16	Registers 5C-5Eh: PWM Configuration	242
24.2.17	Registers 5F-61h: Zone Temperature Range, PWM Frequency	244
24.2.18	Register 62h, 63h: Min/Off, PWM Ramp Rate Control	246
24.2.19	Registers 64-66h: Minimum PWM Duty Cycle.	247
24.2.20	Registers 67-69h: Zone Low Temperature Limit	248
24.2.21	Registers 6A-6Ch: Absolute Temperature Limit	249
24.2.22	Registers 6D-6Eh: Zone Hysteresis Registers	250
24.2.23	Register 70-72h: SMSC Test Register	250
24.2.24	Register 73-78h: SMSC Test Register	251
24.2.25	Register 79h: SMSC Test Register	251
24.2.26	Register 7Ch: Special Function Register.	251
24.2.27	Register 7Eh: Interrupt Enable 1 Register	252
24.2.28	Register 7Fh: Configuration Register	253
24.2.29	Register 80h: Interrupt Enable 2 Register	254
24.2.30	Register 81h: TACH_PWM Association Register	254
24.2.31	Register 82h: Interrupt Enable 3 Register	255
24.2.32	Register 83h: Interrupt Status Register 3	256
24.2.33	Registers 84h-88h: A/D Converter LSbs Registers	256
24.2.34	Registers Registers 89h: SMSC Test Register	257
24.2.35	Registers 8Ah: SMSC Test Register	257
24.2.36	Registers 8Bh: SMSC Test Register	257
24.2.37	Registers 8Ch: SMSC Test Register	257
24.2.38	Registers 8Dh: SMSC Test Register	257
24.2.39	Registers 8Eh: SMSC Test Register	258
24.2.40	Registers 90h-92h: FANTACHX Option Registers	258
24.2.41	Registers 94h-96h: PWMx Option Registers	259
24.2.42	Register 97h: SMSC Test Register	259
24.2.43	Register 98h: SMSC Test Register.	260
24.2.44	Registers 99h-9Ah: Voltage Reading Registers	260

Datasheet

24.2.45	Registers 9B-9EH: Voltage Limit Registers	260
24.2.46	Register A3h: SMSC Test Register	260
24.2.47	Register A4h: SMSC Test Register	260
24.2.48	Register A5h: Interrupt Status Register 1 - Secondary	260
24.2.49	Register A6h: Interrupt Status Register 2 - Secondary	261
24.2.50	Register A7h: Interrupt Status Register 3 - Secondary	261
24.2.51	Register ABh: TACH 1-3 Mode Register	261
24.2.52	Register ADh: SMSC Test Register	262
24.2.53	Registers AE-AFh, B3h: Top Temperature Limit Registers	262
24.2.54	Register B4h: Min Temp Adjust Temp RD1, RD2 (Zones 1 & 3)	262
24.2.55	Register B5h: Min Temp Adjust Temp and Delay AMB (Zone 2)	263
24.2.56	Register B6h: Min Temp Adjust Delay RD1, RD2 (ZONE 1 & 3) Register	263
24.2.57	Register B7h: Min Temp Adjust Enable Register	264
24.2.58	Register B8h: Top Temp Exceeded Status Register	264
24.2.59	Register BAh: SMSC Reserved Register	265
24.2.60	Register BBh: SMSC Reserved Register	265
24.2.61	Register 0BDh: SMSC Reserved Register	265
24.2.62	Register BFh: SMSC Reserved Register	265
24.2.63	Register C0h: SMSC Reserved Register	265
24.2.64	Register C1h: SMSC Reserved Register	266
24.2.65	Registers C4-C5, C9h: THERMTRIP Temperature Limit Zone Registers	266
24.2.66	Register CAh: THERMTRIP Status Register	266
24.2.67	Register CBh: THERMTRIP Output Enable Register	267
24.2.68	Register CEh: SMSC Reserved Register	267
24.2.69	Registers D1,D6,DBh: PWM Max Segment Registers	267
24.2.70	Register E0h: Enable LSbs for Auto Fan	267
24.2.71	Register FFh: SMSC Test Register	268
<hr/>		
Chapter 25	Config Registers	269
25.1	Configuration Registers	271
25.1.1	Global Config Registers	276
25.1.2	Test Registers	278
<hr/>		
Chapter 26	Runtime Register	293
26.1	Runtime Register	293
26.2	Runtime Register Description	303
<hr/>		
Chapter 27	Valid Power Modes	337
<hr/>		
Chapter 28	Operational Description	339
28.1	Maximum Guaranteed Ratings	339
28.1.1	Super I/O section (pins 3 to 112)	339
28.1.2	Hardware Monitoring Block (pins 1 and 2 and pins 113 to 128)	339
28.2	DC Electrical Characteristics	339
28.3	Capacitance Values for Pins	345
<hr/>		
Chapter 29	Timing Diagrams	347
29.1	Power Up Timing	348
29.2	Input Clock Timing	348
29.3	LPC Interface Timing	349
29.4	Floppy Disk Controller Timing	352
29.5	Parallel Port Timing	353
29.6	IR Timing	360
29.7	Serial IRQ Timing	363
29.8	UART Interface Timing	364

29.9	Keyboard/Mouse Interface Timing	364
29.10	Resume Reset Signal Generation	365
29.11	nLEDx Timing	366
29.12	PWM Outputs	366
<hr/>		
Chapter 30	Package Outline	367
<hr/>		
Appendix A	ADC Voltage Conversion	369
<hr/>		
Appendix B	Example Fan Circuits	373
<hr/>		
Appendix C	Test Mode	377
C.1	XNOR-Chain Test Mode Overview	377
C.1.1	Board Test Mode	377

List of Figures

Figure 2.1	SCH3112 Pin Diagram	3
Figure 2.2	SCH3114 Pin Diagram	5
Figure 2.3	SCH116 Pin Diagram	7
Figure 2.4	SCH3116 Summary - 6 Ports	8
Figure 3.1	SCH311X Block Diagram	23
Figure 8.1	Serial Data	80
Figure 8.2	Baud Rate Selection	88
Figure 8.3	Half Duplex Operation with Direction Control	97
Figure 8.4	Reduce Pin Serial Port Control Signal Selection	98
Figure 12.1	SCH311X Keyboard and Mouse Interface	129
Figure 12.2	Keyboard Latch	135
Figure 12.3	Mouse Latch	136
Figure 13.1	GPIO Function Illustration	149
Figure 15.1	8042 Isolation and Keyboard and Mouse Port Swap Representation	157
Figure 18.1	Reset Generation Circuit (For Illustrative Purposes Only)	164
Figure 18.2	PWRGD_OUT Timing	165
Figure 19.1	nPCIRSTx Logic	168
Figure 20.1	Power Control Block Diagram	170
Figure 20.2	nFPRST Debounce Timing	172
Figure 20.3	Power Supply during Normal Operation	174
Figure 20.4	Power Supply After Power Failure (Return to Off)	174
Figure 20.5	Power Supply After Power Failure (Return to On)	175
Figure 20.6	Sample Single-Byte Make Code	177
Figure 20.7	Sample Multi-Byte Make Code	177
Figure 20.8	Option 1: KB_PB_STS wake event fixed pulse width	179
Figure 20.9	Option 2: Assert KB_PB_STS wake event until scan code not programmed make code	179
Figure 20.10	Option 3: De-assert KB_PB_STS when scan code equal break code	180
Figure 21.1	External Battery Circuit	183
Figure 23.1	HWM Block Embedded in SCH311X	187
Figure 23.2	HWM Register Access	188
Figure 23.3	Interrupt Control	193
Figure 23.4	Automatic Fan Control Flow Diagram	202
Figure 23.5	Automatic Fan Control	204
Figure 23.6	Spin Up Reduction Enabled	205
Figure 23.7	Illustration of PWM Ramp Rate Control	207
Figure 23.8	AMTA Illustration, Adjusting Minimum Temperature	215
Figure 23.9	AMTA Interrupt Mapping	216
Figure 23.10	nTHERMTRIP Output Operation	217
Figure 23.11	PWM and Tachometer Concept	219
Figure 24.1	Fan Activity Above Fan Temp Limit	244
Figure 29.1	Power-Up Timing	348
Figure 29.2	Input Clock Timing	348
Figure 29.3	PCI Clock Timing	349
Figure 29.4	Reset Timing	349
Figure 29.5	Output Timing Measurement Conditions, LPC Signals	350
Figure 29.6	Input Timing Measurement Conditions, LPC Signals	350
Figure 29.7	I/O Write	351
Figure 29.8	I/O Read	351
Figure 29.9	DMA Request Assertion through LDRQ#	351
Figure 29.10	DMA Write (First Byte)	351
Figure 29.11	DMA Read (First Byte)	351
Figure 29.12	Floppy Disk Drive Timing (AT Mode Only)	352
Figure 29.13	EPP 1.9 Data or Address Write Cycle	353

Figure 29.14EPP 1.9 Data or Address Read Cycle.	354
Figure 29.15EPP 1.7 Data or Address Write Cycle.	355
Figure 29.16EPP 1.7 Data or Address Read Cycle.	355
Figure 29.17Parallel Port FIFO Timing	357
Figure 29.18ECP Parallel Port Forward Timing	358
Figure 29.19ECP Parallel Port Reverse Timing	359
Figure 29.20IrDA Receive Timing	360
Figure 29.21IrDA Transmit Timing	361
Figure 29.22Amplitude Shift-Keyed IR Receive Timing	362
Figure 29.23Amplitude Shift-Keyed IR Transmit Timing	363
Figure 29.24Setup and Hold Time.	363
Figure 29.25Serial Port Data	364
Figure 29.26Keyboard/Mouse Receive/Send Data Timing	364
Figure 29.27Resume Reset Sequence	365
Figure 29.28nLEDx Timing	366
Figure 29.29PWMx Output Timing	366
Figure 30.1 128 Pin VTQFP Package Outline.	367
Figure B.1 Fan Drive Circuitry for Low Frequency Option (Apply to PWM Driving Two Fans)	373
Figure B.2 Fan Drive Circuitry for Low Frequency Option (Apply to PWM Driving One Fan)	374
Figure B.3 Fan Tachometer Circuitry (Apply to Each Fan)	374
Figure B.4 Remote Diode (Apply to Remote2 Lines).	375
Figure B.5 Suggested Minimum Track Width and Spacing	375
Figure C.1 XNOR-Chain Test Structure.	377

List of Tables

Table 2.1	SCH3112 Summary - 2 Serial Ports	4
Table 2.2	SCH3114 Summary - 4 Serial Ports	6
Table 2.3	SCH311X Signal Difference Summary	8
Table 2.4	SCH311X Pin Core Functions Description (Note 2.14)	9
Table 2.5	SCH3112 Specific Signals (Note 2.15)	15
Table 2.6	SCH3114 Specific Signals (Note 2.15)	17
Table 2.7	SCH3116 Specific Signals (Note 2.15)	18
Table 2.8	Buffer Description	21
Table 5.1	Super I/O Block Addresses	29
Table 6.1	Supported LPC Cycles	31
Table 7.1	Status, Data and Control Registers	35
Table 7.2	Internal 2 Drive Decode – Normal	39
Table 7.3	Tape Select Bits	40
Table 7.4	Drive Type ID	41
Table 7.5	Precompensation Delays	42
Table 7.6	Data Rates	42
Table 7.7	DRV DEN Mapping	43
Table 7.8	Default Precompensation Delays	43
Table 7.9	FIFO Service Delay	45
Table 7.10	Status Register 0	48
Table 7.11	Status Register 1	48
Table 7.12	Status Register 2	49
Table 7.13	Status Register 3	49
Table 7.14	Description of Command Symbols	52
Table 7.15	Instruction Set	55
Table 7.16	Sector Sizes	65
Table 7.17	Effects of MT and N Bits	66
Table 7.18	Skip Bit vs. Read Data Command	66
Table 7.19	Skip Bit vs. Read Deleted Data Command	66
Table 7.20	Result Phase	67
Table 7.21	Verify Command Result Phase	68
Table 7.22	Typical Values for Formatting	70
Table 7.23	Interrupt Identification	72
Table 7.24	Drive Control Delays (ms)	72
Table 7.25	Effects of WGATE and GAP Bits	75
Table 8.1	Addressing the Serial Port	77
Table 8.2	Interrupt Control	80
Table 8.3	Serial Ports Mode Register	86
Table 8.4	Baud Rates	87
Table 8.5	register Reset	88
Table 8.6	Pin Reset	88
Table 8.7	Register Summary for an Individual UART Channel	90
Table 8.8	SCH311X IRQ Sharing Summary	94
Table 8.9	nRTS/nDTR Automatic Direction Control Options	96
Table 9.1	Parallel Port Connector	102
Table 9.2	EPP Pin Descriptions	107
Table 9.3	ECP Pin Descriptions	109
Table 9.4	ECP Register Definitions	111
Table 9.5	Mode Descriptions	111
Table 9.6	Extended Control Register (a)	115
Table 9.7	Extended Control Register (b)	116
Table 9.8	Extended Control Register (c)	116
Table 9.9	Channel/Data Commands Supported in ECP Mode	117

Table 9.10 Parallel Port Floppy Pin Out	120
Table 9.11 PP Buffer Types.	121
Table 10.1 State of Floppy Disk Drive Interface Pins in Powerdown.	123
Table 12.1 I/O Address Map	130
Table 12.2 Host Interface Flags.	130
Table 12.3 Status Register	132
Table 12.4 Resets	133
Table 13.1 GPIO Pin Functionality	139
Table 13.2 SCH311X General Purpose I/O Port Assignments	142
Table 13.3 GPIO Configuration Option	148
Table 13.4 GPIO Read/Write Behavior	149
Table 15.1 PME Interface	153
Table 15.2 PME Events	153
Table 18.1 RESGEN Strap Option	163
Table 18.2 RESGEN Programming	163
Table 18.3 PWRGD_OUT Timing	165
Table 19.1 Buffered PCI outputs Interface	167
Table 19.2 nIDE_RSTDRV Truth Table.	167
Table 19.3 nIDE_RSTDRV Timing	167
Table 20.1 Power Control Interface	169
Table 20.2 Internal PWROK Truth Table.	171
Table 20.3 Definition of APF Bits.	173
Table 20.4 Decoding Keyboard Scan Code for Make Code	178
Table 20.5 Decoding Keyboard Scan Code for Break Code	180
Table 22.1 Security Key Register Summary	185
Table 22.2 Description of Security Key Control (SKC) Register Bits[2:1]	186
Table 23.1 AVG[2:0] BIT DECODER.	190
Table 23.2 ADC Conversion Sequence.	190
Table 23.3 Temperature Data Format	197
Table 23.4 PWM Ramp Rate.	206
Table 23.5 Minimum RPM Detectable Using 3 Edges.	221
Table 23.6 Minimum RPM Detectable Using 2 Edges.	222
Table 24.1 Register Summary.	225
Table 24.2 Voltage vs. Register Reading	231
Table 24.3 Temperature vs. Register Reading	232
Table 24.4 PWM Duty vs Register Reading	234
Table 24.5 Voltage Limits vs. Register Setting	240
Table 24.6 Temperature Limits vs. Register Settings	241
Table 24.7 Fan Zone Setting	243
Table 24.8 Fan Spin-Up Register	244
Table 24.9 PWM Frequency Selection	245
Table 24.10 Register Setting vs. Temperature Range	245
Table 24.11 PWM output below Limit depending on value of Off/Min	246
Table 24.12 PWM Ramp Rate Control.	247
Table 24.13 PWM Duty vs. Register Setting	248
Table 24.14 Temperature Limit vs. Register Setting	248
Table 24.15 Absolute Limit vs. Register Setting.	249
Table 24.16 Hysteresis Settings.	250
Table 24.17 AVG[2:0] BIT DECODER	252
Table 24.18 Programming Options for the PWMx_n[1:0] Bits	268
Table 25.1 SYSOPT Strap Option Configuration Address Select	269
Table 25.2 SCH311X Logical Device Summary	271
Table 25.3 Configuration Register Summary.	272
Table 25.4 Chip-Level (Global) Configuration Registers	276
Table 25.5 Test Register Summary	278

Datasheet

Table 25.6 Logical Device Registers	279
Table 25.7 Base I/O Range for Logical Devices	281
Table 25.8 Primary Interrupt Select Register.	283
Table 25.9 DMA Channel Select	283
Table 25.10 Floppy Disk Controller, Logical Device 0 [Logical Device Number = 0X00]	285
Table 25.11 Parallel Port, Logical Device 3 [Logical Device Number = 0x03]	286
Table 25.12 Serial Port 1, Logical Device 4 [Logical Device Number = 0X04]	286
Table 25.13 Serial Port 2, Logical Device 5 [Logical Device Number = 0X05].	287
Table 25.14 KYBD, Logical Device 7 [Logical Device Number = 0X07].	288
Table 25.15 Logical Device A [Logical Device Number = 0X0A]	288
Table 25.16 Serial Port 3, Logical Device B [Logical Device Number = 0X0B]	289
Table 25.17 Serial Port 4, Logical Device C [Logical Device Number = 0X0C]	290
Table 25.18 Serial Port 5, Logical Device D [Logical Device Number = 0X0D]	290
Table 25.19 Serial Port 6, Logical Device E [Logical Device Number = 0X0E]	291
Table 26.1 SCH311X Runtime Register Summary	293
Table 26.2 Runtime Register POR Summary	297
Table 26.3 Detailed Runtime Register Description	303
Table 27.1 Valid Power States	337
Table 28.1 Buffer Operational Ratings	339
Table 28.2 Capacitance $T_A = 25$; $f_c = 1\text{MHz}$; $V_{CC} = 3.3\text{V} \pm 10\%$	345
Table 29.1 Resume Reset Timing	365
Table 30.1 128 Pin VTQFP Package Parameters.	367
Table A.1 Analog-to-Digital Voltage Conversions for Hardware Monitoring Block.	369
Table C.1 Toggling Inputs in Descending Order	379
Table C.2 Toggling Inputs in Ascending Order	379



Chapter 1 General Description

The SCH3112/SCH3114/SCH3116 Product Family is a 3.3V (Super I/O Block is 5V tolerant) PC99/PC2001 compliant Super I/O controller with an LPC interface. The SCH3112/SCH3114/SCH3116 Product Family also includes Hardware Monitoring capabilities, enhanced Security features, Power Control logic and Motherboard Glue logic.

The SCH3112/SCH3114/SCH3116 Product Family's hardware monitoring capability includes temperature, voltage and fan speed monitoring. It has the ability to alert the system of out-of-limit conditions and automatically control the speeds of multiple fans. There are four analog inputs for monitoring external voltages of +5V, +2.5V, +12V and V_{ccp} (core processor voltage), as well as internal monitoring of the SIO's VCC, VTR, and V_{bat} power supplies. The SCH3112/SCH3114/SCH3116 Product Family includes support for monitoring two external temperatures via thermal diode inputs and an internal sensor for measuring ambient temperature. The nHWM_INT pin is implemented to indicate out-of-limit temperature, voltage, and FANTACH conditions. The hardware monitoring block of the SCH3112/SCH3114/SCH3116 Product Family is accessible via the LPC bus. The same interrupt event reported on the nHWM_INT pin also creates PME wakeup events. A separate THERMTRIP output is available, which generates a pulse output on a programmed over temperature condition. This can be used to generate an reset or shutdown indicator to the system.

The hardware monitoring capability also has programmable automatic FAN control. Three fan tachometer inputs and three pulse width modulator (PWM) outputs are available.

The Motherboard Glue logic includes various power management and system logic including generation of nRSMRST, a programmable Clock output, and reset generation. The reset generation includes a watchdog timer which can be used to generate a reset pulse. The width of this pulse is selectable via an external strapping option.

The SCH3112/SCH3114/SCH3116 Product Family incorporates complete legacy Super I/O functionality including an 8042 based keyboard and mouse controller, an IEEE 1284, EPP, and ECP compatible parallel port, multiple serial ports, one IrDA 1.0 infrared ports, and a floppy disk controller with SMSC's true CMOS 765B core and enhanced digital data separator, The true CMOS 765B core provides 100% compatibility with IBM PC/XT and PC/AT architectures and is software and register compatible with SMSC's proprietary 82077AA core. System related functionality, which offers flexibility to the system designer, General Purpose I/O control functions, and control of two LED's.

The serial ports are fully functional NS16550 compatible UARTs that support data rates up to 1.5 Mbps. There are four, 8 pin Serial Ports and two, 4pin Serial Ports. The reduced pin serial ports have selectable input and output controls. The Serial Ports contain programmable direction control, which will automatically Drive nRTS when the Output Buffer is loaded, then Drive nRTS when the Output Buffer is Empty.

The SCH3112/SCH3114/SCH3116 Product Family is ACPI 1.0/2.0 compatible and therefore supports multiple low power-down modes. It incorporates sophisticated power control circuitry (PCC), which includes support for keyboard.

The SCH3112/SCH3114/SCH3116 Product Family supports the ISA Plug-and-Play Standard register set (Version 1.0a). The I/O Address, DMA Channel and hardware IRQ of each logical device in the SCH3112/SCH3114/SCH3116 Product Family may be reprogrammed through the internal configuration registers. There are up to 480 (960 - Parallel Port) I/O address location options, a Serialized IRQ interface, and Three DMA channels.

Table 1.1 Device Specific Summary

FUNCTION	SCH3112	SCH3114	SCH3116
LPC Bus Interface	YES	YES	YES
Legacy functional Blocks (Note 1.1)	YES	YES	YES
Floppy on Parallel Port Option	YES	YES	YES
Reset Generator	YES	YES	YES
Serial Ports	2	4	6 (Note 1.2)
Programmable Clock Output	YES	YES	YES
IDE / PCI Reset Outputs	YES	YES	NO
Power Button / AC Fail Support	YES	YES	NO
GPIOs	40	40	40
GPIO with VID Compatible Inputs	6	6	6
Dedicated GPIOs	16	0	0
Hardware Monitor	YES	YES	YES

Note 1.1 Legacy Blocks include floppy disk, parallel port, watchdog timer and keyboard controller

Note 1.2 2 of the 6 serial ports have 4 pin interfaces

Chapter 2 Pinout

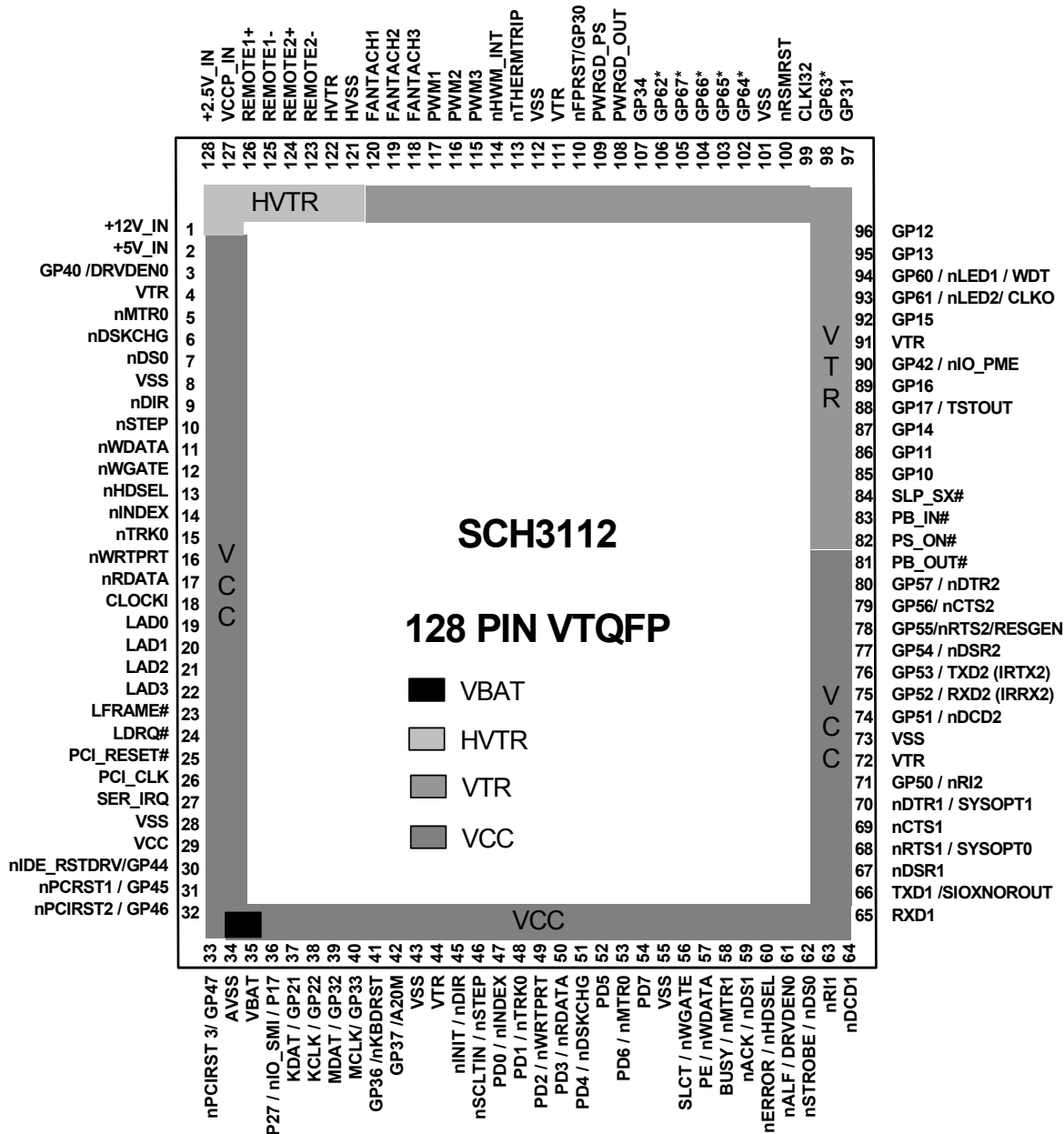

Note:
 SYSOPT1 Pin 68
 SYSOPT0 Pin 70 and
 RESGEN Pin 78 are only sampled during power on configuration

Figure 2.1 SCH3112 Pin Diagram

2.1 SCH311X Pinout Summary

Table 2.1 SCH3112 Summary - 2 Serial Ports

PIN #	NAME	PIN #	NAME	PIN #	NAME	PIN #	NAME
1	+12V_IN	33	nPCIRST3 / GP47	65	RXD1	97	GP31
2	+5V_IN	34	AVSS	66	TXD1/ SIO_XNOR_OUT	98	GP63*
3	GP40 / DRVDE0	35	VBAT	67	nDSR1	99	CLKI32
4	VTR	36	GP27/nIO_SMI/P1 7	68	nRTS1/SYSOPT0	100	nRSMRST
5	nMTR0	37	KDAT/GP21	69	nCTS1	101	VSS
6	nDSKCHG	38	KCLK/GP22	70	nDTR1/SYSOPT1	102	GP64*
7	nDS0	39	MDAT/GP32	71	GP50 / nRI2	103	GP65*
8	VSS	40	MCLK/GP33	72	VTR	104	GP66*
9	nDIR	41	GP36/nKBDRST	73	VSS	105	GP67*
10	nSTEP	42	GP37/A20M	74	GP51 / nDCD2	106	GP62*
11	nWDATA	43	VSS	75	GP52 / RXD2(IRRX2)	107	GP34
12	nWGATE	44	VTR	76	GP53 / TXD2(IRTX2)	108	PWRGD_OUT
13	nHSEL	45	nINIT / nDIR	77	GP54 / nDSR2	109	PWRGD_PS
14	nINDEX	46	nSLCTIN / nSTEP	78	GP55 / nRTS2 / REGEN	110	nFPRST / GP30
15	nTRK0	47	PD0 / nINDEX	79	GP56 / nCTS2	111	VTR
16	nWRTPRT	48	PD1 / nTRK0	80	GP 57 / nDTR2	112	VSS
17	nRDATA	49	PD2 / nWRTPRT	81	PB_OUT#	113	nTHERMTRIP
18	CLOCKI	50	PD3 / nRDATA	82	PS_ON#	114	nHWM_INT
19	LAD0	51	PD4 / nDSKCHG	83	PB_IN#	115	PWM3
20	LAD1	52	PD5	84	SLP_SX#	116	PWM2
21	LAD2	53	PD6 / nMTR0	85	GP10	117	PWM1
22	LAD3	54	PD7	86	GP11	118	FANTACH3
23	LFRAME#	55	VSS	87	GP14	119	FANTACH2
24	LDRQ#	56	SLCT / nWGATE	88	GP17	120	FANTACH1
25	PCI_RESET#	57	PE / nWDATA	89	GP16	121	HVSS
26	PCI_CLK	58	BUSY / nMTR1	90	GP42/nIO_PME_	122	HVTR
27	SER_IRQ	59	nACK / nDS1	91	VTR	123	REMOTE2-
28	VSS	60	nERROR / nHSEL	92	GP15	124	REMOTE2+
29	VCC	61	nALF / DRVDE0	93	GP61/nLED2/CLK O	125	REMOTE1-
30	nIDE_RSTDRV / GP44	62	nSTROBE / nDS0	94	GP60/nLED1/WD T	126	REMOTE1+
31	nPCIRST1 / GP45	63	nRI1	95	GP13	127	VCCP_IN
32	nPCIRST2 / GP46	64	nDCD1	96	GP12	128	+2.5V_IN

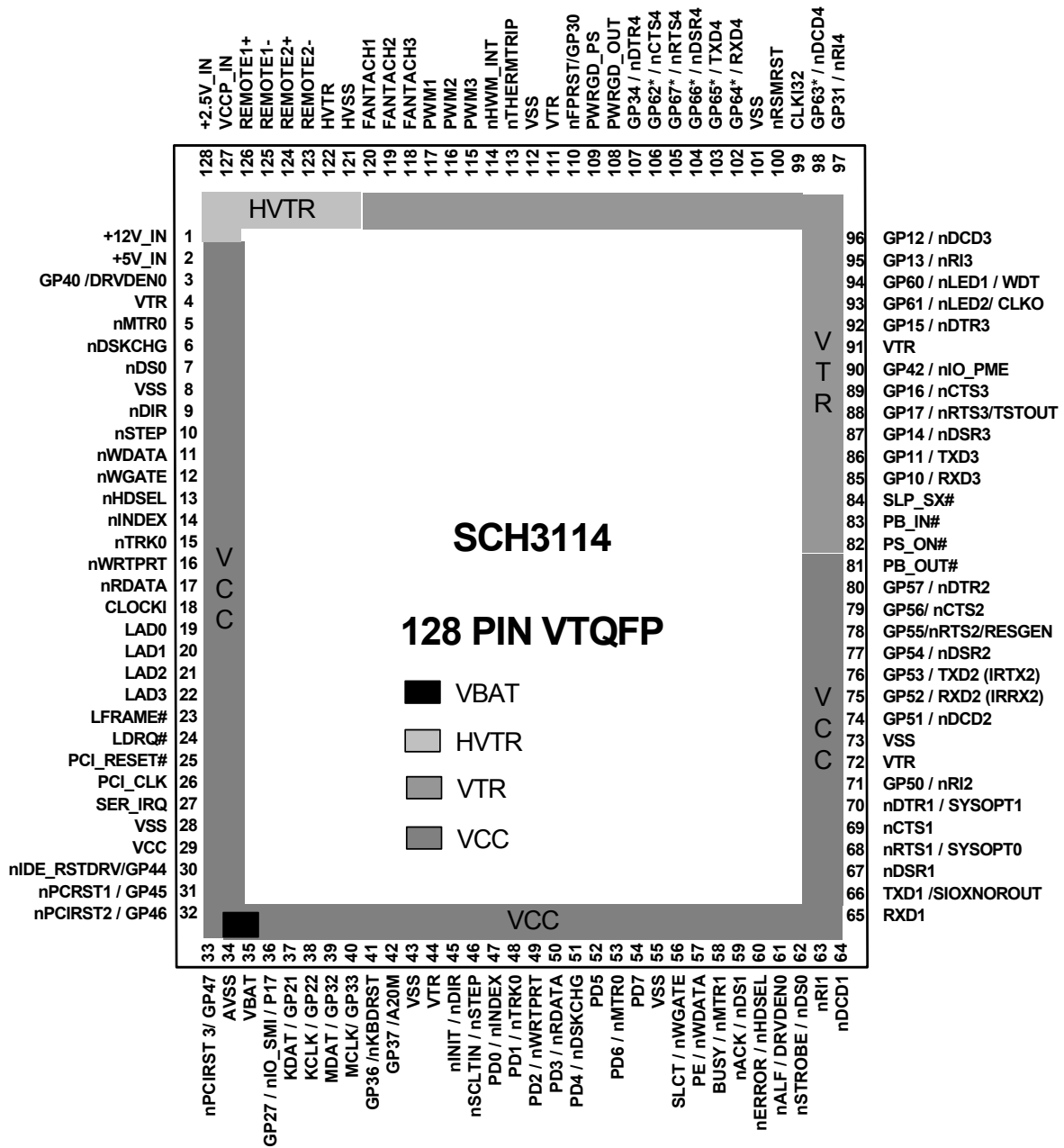

Note:
 SYSOPT1 Pin 68
 SYSOPT0 Pin 70 and
 REGEN Pin 78 are only sampled during power on configuration

Figure 2.2 SCH3114 Pin Diagram

Table 2.2 SCH3114 Summary - 4 Serial Ports

PIN #	NAME	PIN #	NAME	PIN #	NAME	PIN #	NAME
1	+12V_IN	33	nPCIRST3 / GP47	65	RXD1	97	GP31 / nRI4
2	+5V_IN	34	AVSS	66	TXD1/ SIO XNOR_OUT	98	GP63* / nDCD4
3	GP40/DRV DEN0	35	VBAT	67	nDSR1	99	CLKI32
4	VTR	36	GP27/nIO_SMI/P17	68	nRTS1/SYSOPT0	100	nRSMRST
5	nMTR0	37	KDAT/GP21	69	nCTS1	101	VSS
6	nDSKCHG	38	KCLK/GP22	70	nDTR1/SYSOPT1	102	GP64* / RXD4
7	nDS0	39	MDAT/GP32	71	GP50 / nRI2	103	GP65* / TXD4
8	VSS	40	MCLK/GP33	72	VTR	104	GP66* / nDSR4
9	nDIR	41	GP36/nKBDRST	73	VSS	105	GP67* / nRTS4
10	nSTEP	42	GP37/A20M	74	GP51 / nDCD2	106	GP62* / nCTS4
11	nWDATA	43	VSS	75	GP52 / RXD2(IRR2)	107	GP34 / nDTR4
12	nWGATE	44	VTR	76	GP53 / TXD2(IRT2)	108	PWRGD_OUT
13	nHDSEL	45	nINIT / nDIR	77	GP54 / nDSR2	109	PWRGD_PS
14	nINDEX	46	nSLCTIN / nSTEP	78	GP55 / nRTS2 / RESGEN	110	nFPRST / GP30
15	nTRK0	47	PD0 / nINDEX	79	GP56 / nCTS2	111	VTR
16	nWRTPRT	48	PD1 / nTRK0	80	GP 57 / nDTR2	112	VSS
17	nRDATA	49	PD2 / nWRTPRT	81	PB_OUT#	113	nTHERMTRIP
18	CLOCKI	50	PD3 / nRDATA	82	PS_ON#	114	nHWM_INT
19	LAD0	51	PD4 / nDSKCHG	83	PB_IN#	115	PWM3
20	LAD1	52	PD5	84	SLP_SX#	116	PWM2
21	LAD2	53	PD6 / nMTR0	85	GP10/RXD3	117	PWM1
22	LAD3	54	PD7	86	GP11 / TXD3	118	FANTACH3
23	LFRAME#	55	VSS	87	GP14 / nDSR3	119	FANTACH2
24	LDRQ#	56	SLCT / nWGATE	88	GP17 / nRTS3	120	FANTACH1
25	PCI_RESET#	57	PE / nWDATA	89	GP16 / nCTS3	121	HVSS
26	PCI_CLK	58	BUSY / nMTR1	90	GP42/nIO_PME_	122	HVTR
27	SER_IRQ	59	nACK / nDS1	91	VTR	123	REMOTE2-
28	VSS	60	nERROR / nHDSEL	92	GP15 / nDTR3	124	REMOTE2+
29	VCC	61	nALF / DRV DEN0	93	GP61/nLED2/CLK O	125	REMOTE1-
30	nIDE_RSTDRV / GP44	62	nSTROBE / nDS0	94	GP60/nLED1/WD T	126	REMOTE1+
31	nPCIRST1 / GP45	63	nRI1	95	GP13 / nRI3	127	VCCP_IN
32	nPCIRST2 / GP46	64	nDCD1	96	GP12 / nDCD3	128	+2.5V_IN

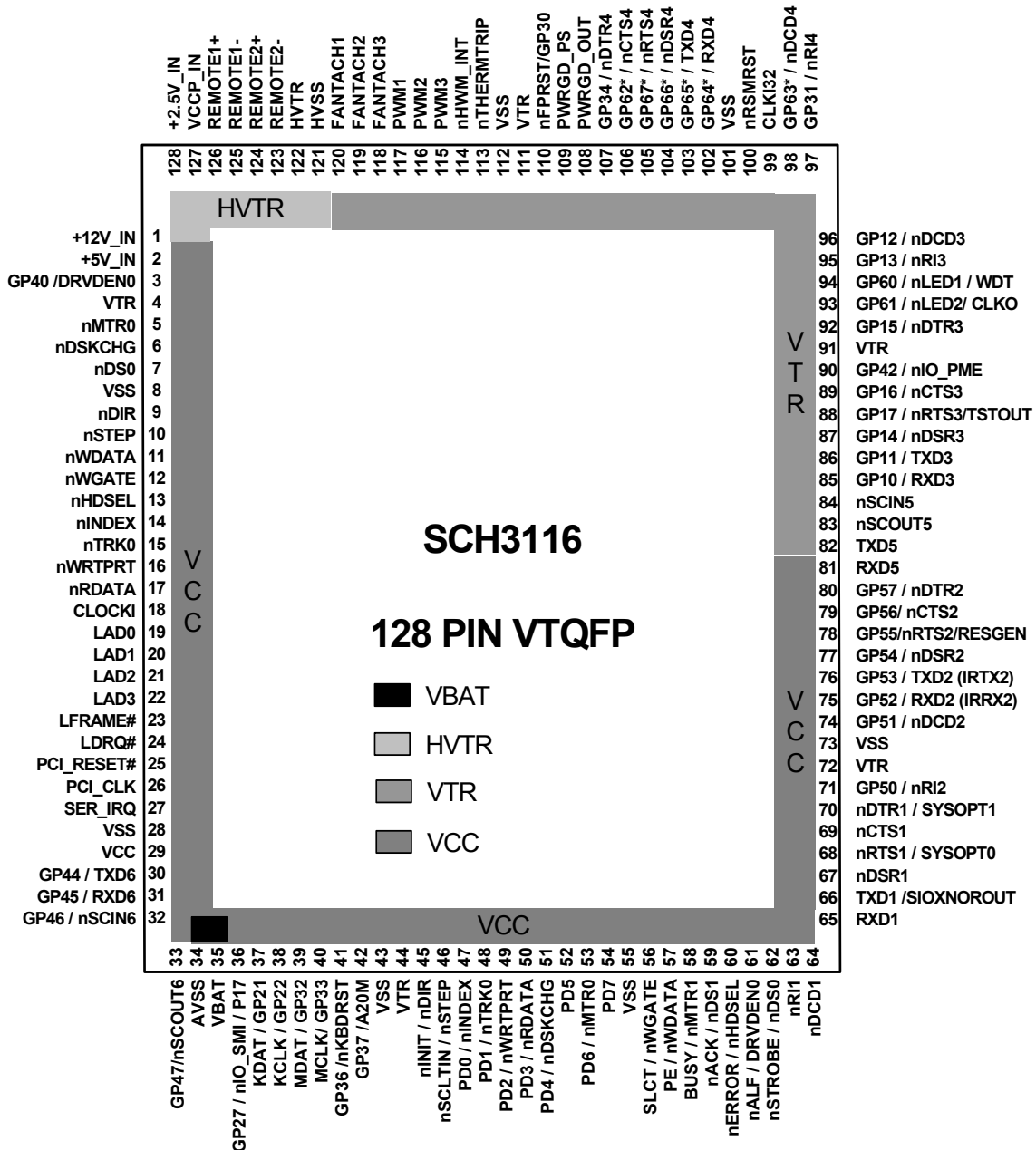

Note:
 SYSOPT1 Pin 68
 SYSOPT0 Pin 70 and
 RESGEN Pin 78 are only sampled during power on configuration

Figure 2.3 SCH116 Pin Diagram

Figure 2.4 SCH3116 Summary - 6 Ports

PIN #	NAME	PIN #	NAME	PIN #	NAME	PIN #	NAME
1	+12V_IN	33	GP47 / nSCOUT6	65	RXD1	97	GP31 / nRI4
2	+5V_IN	34	AVSS	66	TXD1/ SIO_XNOR_OUT	98	GP63* / nDCD4
3	GP40/DRV DEN 0	35	VBAT	67	nDSR1	99	CLKI32
4	VTR	36	GP27/nIO_SMI/P1 7	68	nRTS1/SYSOPT0	100	nRSMRST
5	nMTR0	37	KDAT/GP21	69	nCTS1	101	VSS
6	nDSKCHG	38	KCLK/GP22	70	nDTR1/SYSOPT1	102	GP64* / RXD4
7	nDS0	39	MDAT/GP32	71	GP50 / nRI2	103	GP65* / TXD4
8	VSS	40	MCLK/GP33	72	VTR	104	GP66* / nDSR4
9	nDIR	41	GP36/nKBDRST	73	VSS	105	GP67* / nRTS4
10	nSTEP	42	GP37/A20M	74	GP51 / nDCD2	106	GP62* / nCTS4
11	nWDATA	43	VSS	75	GP52 / RXD2(IRR2)	107	GP34 / nDTR4
12	nWGATE	44	VTR	76	GP53 / TXD2(IRT2)	108	PWRGD_OUT
13	nHDSSEL	45	nINIT / nDIR	77	GP54 / nDSR2	109	PWRGD_PS
14	nINDEX	46	nSLCTIN / nSTEP	78	GP55 / nRTS2 / REGEN	110	nFPRST / GP30
15	nTRK0	47	PD0 / nINDEX	79	GP56 / nCTS2	111	VTR
16	nWRTPRT	48	PD1 / nTRK0	80	GP 57 / nDTR2	112	VSS
17	nRDATA	49	PD2 / nWRTPRT	81	RXD5	113	nTHERMTRIP
18	CLOCKI	50	PD3 / nRDATA	82	TXD5	114	nHWM_INT
19	LAD0	51	PD4 / nDSKCHG	83	nSCOUT5	115	PWM3
20	LAD1	52	PD5	84	nSCIN5	116	PWM2
21	LAD2	53	PD6 / nMTR0	85	GP10/RXD3	117	PWM1
22	LAD3	54	PD7	86	GP11 / TXD3	118	FANTACH3
23	LFRAME#	55	VSS	87	GP14 / nDSR3	119	FANTACH2
24	LDRQ#	56	SLCT / nWGATE	88	GP17 / nRTS3	120	FANTACH1
25	PCI_RESET#	57	PE / nWDATA	89	GP16 / nCTS3	121	HVSS
26	PCI_CLK	58	BUSY / nMTR1	90	GP42/nIO_PME_	122	HVTR
27	SER_IRQ	59	nACK / nDS1	91	VTR	123	REMOTE2-
28	VSS	60	nERROR / nHDSSEL	92	GP15 / nDTR3	124	REMOTE2+
29	VCC	61	nALF / DRV DEN0	93	GP61/nLED2/CLK O	125	REMOTE1-
30	GP44 / TXD6	62	nSTROBE / nDS0	94	GP60/nLED1/WD T	126	REMOTE1+
31	GP45 / RXD6	63	nRI1	95	GP13 / nRI3	127	VCCP_IN
32	GP46 / nSCIN6	64	nDCD1	96	GP12 / nDCD3	128	+2.5V_IN

Table 2.3 SCH311X Signal Difference Summary

PIN #	SCH3112	SCH3114	SCH3116
30	nIDE_RSTDRV / GP44	nIDE_RSTDRV / GP44	GP44 / TXD6
31	nPCIRST1 / GP45	nPCIRST1 / GP45	GP45 / RXD6

Table 2.3 SCH311X Signal Difference Summary (continued)

PIN #	SCH3112	SCH3114	SCH3116
32	nPCIRST2 / GP46	nPCIRST2 / GP46	GP46 / nSCIN6
33	nPCIRST3 / GP47	nPCIRST3 / GP47	GP47 / nSCOUT6
81	PB_OUT#	PB_OUT#	RXD5
82	PS_ON#	PS_ON#	TXD5
83	PB_IN#	PB_IN#	nSCOUT5
84	SLP_SX#	SLP_SX#	nSCIN5
85	GP10	GP10/RXD3	GP10/RXD3
86	GP11	GP11/TXD3	GP11/TXD3
87	GP14	GP14/nDSR3	GP14/nDSR3
88	GP17	GP17/nRTS3	GP17/nRTS3
89	GP16	GP16/nCTS3	GP16/nCTS3
92	GP15	GP15/nDTR3	GP15/nDTR3
95	GP13	GP13/nRI3	GP13/nRI3
96	GP12	GP12/nDCD3	GP12/nDCD3
97	GP31	GP31 / nRI4	GP31 / nRI4
98	GP63*	GP63* / nDCD4	GP63* / nDCD4
102	GP64*	GP64* / RXD4	GP64* / RXD4
103	GP65*	GP65* / TXD4	GP65* / TXD4
104	GP66*	GP66* /nDSR4	GP66* /nDSR4
105	GP67*	GP67* / nRTS4	GP67* / nRTS4
106	GP62*	GP62* /nCTS4	GP62* /nCTS4
107	GP34	GP34 / nDTR4	GP34 / nDTR4

2.2 Pin Functions

The SCH311X family of devices have the same basic pinout for legacy functions, as shown in [Table 2.5](#). The pin descriptions for the SCH3112 is shown in [Table 2.6](#). Signals specific to the SCH3114 are shown in [Table 2.7](#). Signals specific to the SCH3116 are shown in [Table 2.8](#).

Table 2.4 SCH311X Pin Core Functions Description (Note 2.14)

PIN	NOTE	NAME	DESCRIPTION	VCC POWER PLANE	VTR-POWER PLANE	VCC=0 OPERATION (Note 2.16)	BUFFER MODES (Note 2.1)
POWER PINS (16)							
29	2.3 , 2.4	VCC	+3.3 Volt Supply Voltage				

Table 2.4 SCH311X Pin Core Functions Description (Note 2.14) (continued)

PIN	NOTE	NAME	DESCRIPTION	VCC POWER PLANE	VTR-POWER PLANE	VCC=0 OPERATION (Note 2.16)	BUFFER MODES (Note 2.1)
4,44,72,91,111	2.3, 2.4	VTR	+3.3 Volt Standby Supply Voltage				
35	2.8	VBAT	+3.0 Volt Battery Supply)				
8,28,43,55,73,101,112		VSS	Ground				
34		AVSS	Analog Ground				
122	2.3	HVTR	Analog Power. +3.3V VTR pin dedicated to the Hardware Monitoring block. HVTR is powered by +3.3V Standby power VTR.				
123	2.3	HVSS	Analog Ground. Internally connected to all of the Hardware Monitoring Block circuitry.				
CLOCK PINS (2)							
99		CLKI32	32.768kHz Trickle Clock Input		CLKI32	No Gate	IS
18		CLOCKI	14.318MHz Clock Input	CLOCKI			IS
LPC INTERFACE (9)							
19-22		LAD[3:0]	Multiplexed Command Address and Data	LAD[3:0]		GATE/ Hi-Z	PCI_IO
23		LFRAME#	Frame signal. Indicates start of new cycle and termination of broken cycle	LFRAME#		GATE	PCI_I
24		LDRQ#	Encoded DMA Request	LDRQ#		GATE/Hi-Z	PCI_O
25		PCI_RESET#	PCI Reset	PCI_RESET#		NO GATE	PCI_I
26		PCI_CLK	PCI Clock	PCI_CLK		GATE	PCI_ICLK
27		SER_IRQ	Serial IRQ	SER_IRQ		GATE / Hi-Z	PCI_IO
FDD INTERFACE (13)							
3	2.9	GP40/DRVDEN0	General Purpose I/O /Drive Density Select 0	GP40/DRVDEN0	GP40	GP40 NO GATE / HI-Z	(I/O12/OD12)/ (O12/OD12)

Datasheet

Table 2.4 SCH311X Pin Core Functions Description (Note 2.14) (continued)

PIN	NOTE	NAME	DESCRIPTION	VCC POWER PLANE	VTR-POWER PLANE	VCC=0 OPERATION (Note 2.16)	BUFFER MODES (Note 2.1)
5		nMTR0	Motor On 0	nMTR0		Hi-Z	(O12/OD12)
6		nDSKCHG	Disk Change	nDSKCHG		GATE	IS
7		nDS0	Drive Select 0	nDS0		HI-Z	(O12/OD12)
9		nDIR	Step Direction	nDIR		HI-Z	(O12/OD12)
10		nSTEP	Step Pulse	nSTEP		HI-Z	(O12/OD12)
11		nWDATA	Write Disk Data	nWDATA		HI-Z	(O12/OD12)
12		nWGATE	Write Gate	nWGATE		HI-Z	(O12/OD12)
13		nHDSEL	Head Select	nHDSEL		HI-Z	(O12/OD12)
14		nINDEX	Index Pulse Input	nINDEX		GATE	IS
15		nTRK0	Track 0	nTRK0		GATE	IS
16		nWRTPRT	Write Protected	nWRTPRT		GATE	IS
17		nRDATA	Read Disk Data	nRDATA		GATE	IS
SERIAL PORT 1 INTERFACE (8)							
65		RXD1	Receive Data 1	RXD1		GATE	IS
66		TXD1 /SIO XNOR_OUTPUT	Transmit Data 1 / XNOR-Chain test mode Output for SIO block	TXD1 /SIO XNOR_OUTPUT		HI-Z	O12/O12
67		nDSR1	Data Set Ready 1	nDSR1		GATE	I
68	2.7	nRTS1/ SYSOPT0	Request to Send 1/ SYSOPT (Configuration Port Base Address Control)	nRTS1/ SYSOPT0		GATE/ Hi-Z	OP14/I
69		nCTS1	Clear to Send 1	nCTS1		GATE	I
70		nDTR1 / SYSOPT1	Data Terminal Ready 1	nDTR1 / SYSOPT1		GATE/ Hi-Z	O6
63	2.9	nRI1	Ring Indicator 1		nRI1	GATE	IS
64		nDCD1	Data Carrier Detect 1	nDCD1		GATE	I
SERIAL PORT 2 INTERFACE (8)							

Table 2.4 SCH311X Pin Core Functions Description (Note 2.14) (continued)

PIN	NOTE	NAME	DESCRIPTION	VCC POWER PLANE	VTR-POWER PLANE	VCC=0 OPERATION (Note 2.16)	BUFFER MODES (Note 2.1)
71	2.9	GP50 / nRI2	Ring Indicator 2	GP50	nRI2	NO GATE/ HI-Z	I/ IOD8
74	2.9	GP51 / nDCD2	Data Carrier Detect 2	GP51 / nDCD2		NO GATE/ HI-Z	I
75	2.9	GP52 / RXD2 (IRRX)	Receive Data 2 (IRRX)	GP52 / RXD2 (IRRX)		NO GATE/ HI-Z	IS
76	2.11, 2.9	GP53 / TXD2 (IRTX)	Transmit Data 2 (IRTX)	GP53 / TXD2 (IRTX)		NO GATE/ HI-Z	O12
77	2.9	GP54 / nDSR2	Data Set Ready 2	GP54 / nDSR2		NO GATE/ HI-Z	I
78	2.9	GP55 / nRTS2 / RESGEN	Request to Send 2 / Reset Generator Pulse Width Strap Option	GP55 / nRTS2 / RESGEN		NO GATE/ HI-Z	OP14 / I
79	2.9	GP56 / nCTS2	Clear to Send 2	GP56 / nCTS2		NO GATE/ HI-Z	I
80	2.9	GP57 / nDTR2	Data Terminal Ready 2	GP57 / nDTR2		NO GATE/ HI-Z	O6
SHARED PARALLEL PORT / FDC INTRERFACE (17)							
45	2.12	nINIT / nDIR	Initiate Output	nINIT / nDIR		GATE / HI-Z	(OD14/OP14)
46	2.12	nSLCTIN / nSTEP	Printer Select Input	nSLCTIN / nSTEP		GATE / HI-Z	(OD14/OP14)
47	2.12	PD0 / nINDEX	Port Data 0	PD0 / nINDEX		GATE / HI-Z	IOP14
48	2.12	PD1 / nTRK0	Port Data 1	PD1 / nTRK0		GATE / HI-Z	IOP14
49	2.12	PD2 / nWRTPRT	Port Data 2	PD2 / nWRTPRT		GATE / HI-Z	IOP14
50	2.12	PD3 / nRDATA	Port Data 3	PD3 / nRDATA		GATE / HI-Z	IOP14
51	2.12	PD4 / nDSKCHG	Port Data 4	PD4 / nDSKCHG		GATE / HI-Z	IOP14
52	2.12	PD5	Port Data 5	PD5		GATE / HI-Z	IOP14
53	2.12	PD6 / nMTR0	Port Data 6	PD6 / nMTR0		GATE / HI-Z	IOP14
54	2.12	PD7	Port Data 7	PD7		GATE / HI-Z	IOP14

Datasheet

Table 2.4 SCH311X Pin Core Functions Description (Note 2.14) (continued)

PIN	NOTE	NAME	DESCRIPTION	VCC POWER PLANE	VTR-POWER PLANE	VCC=0 OPERATION (Note 2.16)	BUFFER MODES (Note 2.1)
56	2.12	SLCT / nWGATE	Printer Selected Status	SLCT / nWGATE		GATE / HI-Z	I
57	2.12	PE / nWDATA	Paper End	PE / nWDATA		GATE / HI-Z	I
58	2.12	BUSY / nMTR1	Busy	BUSY / nMTR1		GATE / HI-Z	I
59	2.12	nACK / nDS1	Acknowledge	nACK / nDS1		GATE / HI-Z	I
60	2.12	nERROR / nHDSEL	Error	nERROR / nHDSEL		GATE / HI-Z	I
61	2.12	nALF / DRVDE N0	Autofeed Output	nALF / DRVDE N0		GATE / HI-Z	(OD14/OP14)
62	2.12	nSTROB E / nDS0	Strobe Output	nSTROB E / nDS0		GATE / HI-Z	(OD14/OP14)
KEYBOARD/MOUSE INTERFACE (6)							
37	2.9	KDAT/GP 21	Keyboard Data I/O General Purpose I/O	KDAT/GP 21		NO GATE / HI-Z	(I/OD16)/ (I/O16/OD16)
38	2.9	KCLK/GP 22	Keyboard Clock I/O General Purpose I/O	KCLK/GP 22		NO GATE / HI-Z	I/OD16)/ (I/O16/OD16)
39	2.9	MDAT/GP 32	Mouse Data I/O /General Purpose I/O	MDAT/GP 32		NO GATE / HI-Z	(I/OD16) /(I/O16/OD16)
40	2.9	MCLK/GP 33	Mouse Clock I/O /General Purpose I/O	MCLK/GP 33		NO GATE / HI-Z	(I/O16/OD16) /(I/OD16)
41	2.6	GP36/ nKBDRS T	General Purpose I/O. GPIO can be configured as an Open-Drain Output. Keyboard Reset Open- Drain Output (Note 10)	GP36/ nKBDRST		NO GATE / HI-Z	(I/O8/OD8) /OD8
42	2.6	GP37/ A20M	General Purpose I/O. GPIO can be configured as an Open-Drain Output. Gate A20 Open-Drain Output (Note 10)	GP37/ A20M		NO GATE / HI-Z	(I/O8/OD8) /OD8
MISCELLANEOUS PINS (5)							

Table 2.4 SCH311X Pin Core Functions Description (Note 2.14) (continued)

PIN	NOTE	NAME	DESCRIPTION	VCC POWER PLANE	VTR-POWER PLANE	VCC=0 OPERATION (Note 2.16)	BUFFER MODES (Note 2.1)
90		GP42/ nIO_PME	General Purpose I/O. Power Management Event Output. This active low Power Management Event signal allows this device to request wake-up in either S3 or S5 and below.		GP42/ nIO_PME	NO GATE	((I/O12/OD12) (O12/OD12))
94	2.8, 2.9	GP60 /nLED1 /WDT	General Purpose I/O /nLED1 Watchdog Timer Output		GP60 /nLED1 /WDT	NO GATE	((I/O12/OD12) (O12/OD12) (O12/OD12))
110		nFPRST / GP30	Front Panel Reset / General Purpose IO		nFPRST / GP30	NO GATE	ISPU_400 /
109		PWRGD_ PS	Power Good Input from Power Supply		PWRGD_ _PS	NO GATE	ISPU_400
108		PWRGD_ OUT	Power Good Output – Open Drain		PWRGD_ _OUT	NO GATE	OD8
100		nRSMRS T	Resume Reset Output		nRSMRS T	NO GATE	O8
93	2.8, 2.9	GP61 /nLED2 / CLKO	General Purpose I/O /nLED2 / Programmable Clock Output		GP61 /nLED2 / CLKO	NO GATE	((I/O12/OD12) (O12/OD12))
36	2.9	GP27 /nIO_SMI /P17	General Purpose I/O /System Mgt. Interrupt /8042 P17 I/O	GP27 /nIO_SMI /P17	GP27	/ HI-Z	((I/O12/OD12) (O12/OD12) (I/O12/OD12))
HARDWARE MONITORING BLOCK (23)							
114		nHWM_I NT	Interrupt output for Hardware monitor		nHWM_I NT		OD8
2	2.10	+5V_IN	Analog input for +5V	HVTR			I _{AN}
128	2.10	+2.5_IN	Analog input for +2.5V	HVTR			I _{AN}
127	2.10	VCCP_IN	Analog input for +V _{ccp} (processor voltage: 1.5 V nominal).	HVTR			I _{AN}
1	2.10	+12V_IN	Analog input for +12V	HVTR			I _{AN}
125		REMOTE 1-	This is the negative Analog input (current sink) from the remote thermal diode 1.	HVTR			I _{AND-}

Datasheet

Table 2.4 SCH311X Pin Core Functions Description (Note 2.14) (continued)

PIN	NOTE	NAME	DESCRIPTION	VCC POWER PLANE	VTR-POWER PLANE	VCC=0 OPERATION (Note 2.16)	BUFFER MODES (Note 2.1)
126		REMOTE 1+	This is the positive input (current source) from the remote thermal diode 1.	HVTR			I _{AND+}
123		REMOTE 2-	This is the negative Analog input (current sink) from the remote thermal diode 2.	HVTR			I _{AND-}
124		REMOTE 2+	This is the positive input (current source) from the remote thermal diode 2.	HVTR			I _{AND+}
117		PWM1	Fan Speed Control 1 Output.		PWM1		OD8
118		PWM2	Fan Speed Control 2 Output		PWM2		OD8
119		PWM3	Fan Speed Control 3Output		PWM3		OD8
113		nTHERM TRIP	Thermtrip output		nTHERM TRIP		OD_PH
120		FANTAC H1	Tachometer Input 1 for monitoring a fan.		FANTAC H1		I _M
121		FANTAC H2	Tachometer Input 2 for monitoring a fan.		FANTAC H2		I _M
122		FANTAC H3	Tachometer Input 4 for monitoring a fan.		FANTAC H3		I _M

Table 2.5 SCH3112 Specific Signals (Note 2.15)

PIN	NOTE	NAME	DESCRIPTION	VCC POWER PLANE	VTR POWER PLANE	VCC=0 OPERATION (Note 2.16)	BUFFER MODES (Note 2.1)
RESET OUTPUTS							
33	2.13	nPCIRST3 / GP47	PCI Reset output 3 GPIO with schmidt trigger input		GP47 / nPCIRST 3	NO GATE	(IO8/IOD8)
32	2.13	nPCIRST2 / GP46	PCI Reset output 2 GPIO with schmidt trigger input		nPCIRST 2	NO GATE	(IO8/IOD8)
31	2.13	nPCIRST1 / GP45	PCI Reset output1 GPIO with schmidt trigger input		GP45 / nPCIRST 1	NO GATE	(IO8/IOD8)
30	2.13	nIDE_RST DRV / GP44	IDE Reset output GPIO with schmidt trigger input		GP44 / nIDE_RS TDRV	NO GATE	(IO8/IOD8)
GLUE LOGIC							

Table 2.5 SCH3112 Specific Signals (Note 2.15) (continued)

PIN	NOTE	NAME	DESCRIPTION	VCC POWER PLANE	VTR POWER PLANE	VCC=0 OPERATION (Note 2.16)	BUFFER MODES (Note 2.1)
83		PB_IN# /	Power Button In is used to detect a power button event /		PB_IN#		I/ (O8/OD8)
84	2.9	SLP_SX#	Sx Sleep State Input Pin. /		SLP_SX#	NO GATE	I/ I
81		PB_OUT#	Power Button Out/		PB_OUT #	NO GATE	(O8/OD8) IS
82		PS_ON#	Power supply On/		PS_ON#	NO GATE	OD8 / (O12)
GPIO							
95	2.9	GP13	GPIO		GP13	NO GATE	I/ IO8
96	2.9	GP12	GPIO		GP12	NO GATE	I
85	2.9	GP10	GPIO	GP10		HI-Z	IS
86	2.11, 2.9	GP11	GPIO		GP11	NO GATE	O12
87	2.9	GP14	GPIO		GP14	NO GATE	I
88	2.9	GP17 //	GPIO /	GP17			OP14 / I
89	2.9	GP16	GPIO	GP16			I
92	2.9	GP15	GPIO	GP15			O6
97	2.9	GP31	GPIO		GP31	NO GATE	I
98	2.9	GP63*	GPIO with I_VID buffer Input		GP63*	NO GATE	I
102	2.9	GP64*	GPIO with I_VID buffer Input		GP64*	NO GATE	IS
103	2.11, 2.9	GP65*	GPIO with I_VID buffer Input		GP65*	NO GATE	O12
104	2.9	GP66*	GPIO with I_VID buffer Input		GP66*	NO GATE	I
105	2.9	GP67*	GPIO with I_VID buffer Input		GP67*	NO GATE	OP14 / I
106	2.9	GP62*	GPIO with I_VID buffer Input		GP62*	NO GATE	I
107	2.9	GP34	GPIO		GP34	NO GATE	O6

Datasheet

Table 2.6 SCH3114 Specific Signals (Note 2.15)

PIN	NOTE	NAME	DESCRIPTION	VCC POWER PLANE	VTR-POWER PLANE	VCC=0 OPERATION (Note 2.16)	BUFFER MODES (Note 2.1)
33	2.13	nPCIRST3 / GP47	PCI Reset output 3 GPIO with schmidt trigger input		GP47 / nPCIRST3	NO GATE	(IO8/IOD8)
32	2.13	nPCIRST2 / GP46	PCI Reset output 2 GPIO with schmidt trigger input		nPCIRST2	NO GATE	(IO8/IOD8)
31	2.13	nPCIRST1 / GP45	PCI Reset output1 GPIO with schmidt trigger input		GP45 / nPCIRST1	NO GATE	(IO8/IOD8)
30	2.13	nIDE_RST DRV / GP44	IDE Reset output GPIO with schmidt trigger input		GP44 / nIDE_RSTDRV	NO GATE	(IO8/IOD8)
GLUE LOGIC							
83		PB_IN# /	Power Button In is used to detect a power button event /		PB_IN#	NO GATE	I/ (O8/OD8)
84	2.9	SLP_SX#	Sx Sleep State Input Pin. /		SLP_SX#	NO GATE	I/ I
81		PB_OUT#	Power Button Out/		PB_OUT#	NO GATE	(O8/OD8) IS
82		PS_ON#	Power supply On/		PS_ON#	NO GATE	OD8 / (O12)
SERIAL PORT 3 INTERFACE (8)							
95	2.9	GP13 / nRI3	GPIO / Ring Indicator 3		GP13 / nRI3	NO GATE	I/ IO8
96	2.9	GP12 / nDCD3	GPIO / Data Carrier Detect 3	nDCD3	GP12	NO GATE	I
85	2.9	GP10 / RXD3	GPIO / Receive Data 3	GP10 / RXD3		/ HI-Z	IS
86	2.11, 2.9	GP11 / TXD3	GPIO / Transmit Data 3	TXD3	GP11	/ HI-Z	O12
87	2.9	GP14 / nDSR3	GPIO / Data Set Ready 3	nDSR3	GP14	NO GATE	I
88	2.9	GP17 / nRTS3/	GPIO / Request to Send 3	GP17 / nRTS3/		/ HI-Z	OP14 / I
89	2.9	GP16 / nCTS3	GPIO / Clear to Send 3	GP16 / nCTS3		/ HI-Z	I
92	2.9	GP15 / nDTR3	GPIO / Data Terminal Ready 3	GP15 / nDTR3		/ HI-Z	O6
SERIAL PORT 4 INTERFACE (8)							

Table 2.6 SCH3114 Specific Signals (Note 2.15) (continued)

PIN	NOTE	NAME	DESCRIPTION	VCC POWER PLANE	VTR-POWER PLANE	VCC=0 OPERATION (Note 2.16)	BUFFER MODES (Note 2.1)
97	2.9	GP31 / nRI4	GPIO / Ring Indicator 4		GP31 / nRI4	NO GATE	I
98	2.9	GP63* / nDCD4	GPIO with I_VID buffer Input / Data Carrier Detect 4	nDCD4	GP63*	NO GATE	I
102	2.9	GP64* / RXD4	GPIO with I_VID buffer Input / Receive Data 4	RXD4	GP64*	NO GATE	IS
103	2.11, 2.9	GP65* / TXD4	GPIO with I_VID buffer Input / Transmit Data 4	TXD4	GP65*	/ HI-Z	O12
104	2.9	GP66* / nDSR4	GPIO with I_VID buffer Input / Data Set Ready 4	nDSR4	GP66*	NO GATE	I
105	2.9	GP67* / nRTS4	GPIO with I_VID buffer Input / Request to Send 4	nRTS4	GP67*	/ HI-Z	OP14 / I
106	2.9	GP62* / nCTS4	GPIO with I_VID buffer Input / Clear to Send 4	nCTS4	GP62*	NO GATE	I
107	2.9	GP34 / nDTR4	GPIO / Data Terminal Ready 4	nDTR4	GP34	/ HI-Z	O6

Table 2.7 SCH3116 Specific Signals (Note 2.15)

PIN	NOTE	NAME	DESCRIPTION	VCC POWER PLANE	VTR-POWER PLANE	VCC=0 OPERATION (Note 2.16)	BUFFER MODES (Note 2.1)
SERIAL PORT 6 I/F							
33	2.13	GP47 / nSCOUT6	GPIO with schmidt trigger input Serial Port 6 output control	nSCOUT6	GP47 /	HI-Z	(IO8/IOD8)
32	2.13	GP46 / nSCIN6	GPIO with schmidt trigger input Serial Port 6 input Control		GP46 / nSCIN6	NO GATE	(IO8/IOD8)
31	2.13	GP45 / RXD6	GPIO with schmidt trigger input Receive serial port 6	RXD6	GATE	PG	(IO8/IOD8)
30	2.13	GP44 / TXD6	GPIO with schmidt trigger input Serial Port 6 Transmit	TXD6	GP44	NO GATE/ HI-Z	(IO8/IOD8)
SERIAL PORT 5 I/F							

Datasheet

Table 2.7 SCH3116 Specific Signals (Note 2.15) (continued)

PIN	NOTE	NAME	DESCRIPTION	VCC POWER PLANE	VTR-POWER PLANE	VCC=0 OPERATION (Note 2.16)	BUFFER MODES (Note 2.1)
83		nSCOUT5	Serial Port 5 out control	nSCOUT5		/ HI-Z	I/ (O8/OD8)
84	2.9	nSCIN5	Serial Port 5 input Control		nSCIN5	NO GATE	I/ I
81		RXD5	Receive 5	RXD5		GATE	(O8/OD8) IS
82		TXD5	Serial Port 5 Transmit	TXD5		NOGATE / HI-Z	OD8 / (O12)
SERIAL PORT 3 INTERFACE (8)							
95	2.9	GP13 / nRI3	GPIO / Ring Indicator 3		GP13 / nRI3	NO GATE	I/ IO8
96	2.9	GP12 / nDCD3	GPIO / Data Carrier Detect 3	nDCD3	GP12	NO GATE	I
85	2.9	GP10 / RXD3	GPIO / Receive Data 3	GP10 / RXD3		/ HI-Z	IS
86	2.11, 2.9	GP11 / TXD3	GPIO / Transmit Data 3	TXD3	GP11	/ HI-Z	O12
87	2.9	GP14 / nDSR3	GPIO / Data Set Ready 3	nDSR3	GP14	NO GATE	I
88	2.9	GP17 / nRTS3/	GPIO / Request to Send 3	GP17 / nRTS3/		/ HI-Z	OP14 / I
89	2.9	GP16 / nCTS3	GPIO / Clear to Send 3	GP16 / nCTS3		/ HI-Z	I
92	2.9	GP15 / nDTR3	GPIO / Data Terminal Ready 3	GP15 / nDTR3		/ HI-Z	O6
SERIAL PORT 4 INTERFACE (8)							
97	2.9	GP31 / nRI4	GPIO / Ring Indicator 4		GP31 / nRI4	NO GATE	I
98	2.9	GP63* / nDCD4	GPIO with I_VID buffer Input / Data Carrier Detect 4	nDCD4	GP63*	NO GATE	I
102	2.9	GP64* / RXD4	GPIO with I_VID buffer Input / Receive Data 4	RXD4	GP64*	NO GATE	IS
103	2.11, 2.9	GP65* / TXD4	GPIO with I_VID buffer Input / Transmit Data 4	TXD4	GP65*	/ HI-Z	O12
104	2.9	GP66* / nDSR4	GPIO with I_VID buffer Input / Data Set Ready 4	nDSR4	GP66*	NO GATE	I

Table 2.7 SCH3116 Specific Signals (Note 2.15) (continued)

PIN	NOTE	NAME	DESCRIPTION	VCC POWER PLANE	VTR-POWER PLANE	VCC=0 OPERATION (Note 2.1 6)	BUFFER MODES (Note 2.1)
105	2.9	GP67* / nRTS4	GPIO with I_VID buffer Input / Request to Send 4	nRTS4	GP67*	/ HI-Z	OP14 / I
106	2.9	GP62* / nCTS4	GPIO with I_VID buffer Input / Clear to Send 4	nCTS4	GP62*	NO GATE	I
107	2.9	GP34 / nDTR4	GPIO / Data Terminal Ready 4	nDTR4	GP34	/ HI-Z	O6

Note: The “n” as the first letter of a signal name or the “#” as the suffix of a signal name indicates an “Active Low” signal.

Note 2.1 Buffer types per function on multiplexed pins are separated by a slash “/”. Buffer types in parenthesis represent multiple buffer types for a single pin function.

Note 2.2 Pins that have input buffers must always be held to either a logical low or a logical high state when powered. Bi-directional buses that may be trisected should have either weak external pull-ups or pull-downs to hold the pins in a logic state (i.e., logic states are VCC or ground).

Note 2.3 VCC and VSS pins are for Super I/O Blocks. HVTR and HVSS are dedicated for the Hardware Monitoring Block.

Note 2.4 VTR can be connected to VCC if no wake-up functionality is required.

Note 2.5 The Over Current Sense Pin requires an external pull-up (30ua pull-up is suggested).

Note 2.6 External pull-ups must be placed on the nKBDRST and A20M pins. These pins are GPIOs that are inputs after an initial power-up (VTR POR). If the nKBDRST and A20M functions are to be used, the system must ensure that these pins are high.

Note 2.7 The nRTS1/SYSOPT0 pin requires an external pull-down resistor to put the base I/O address for configuration at 0x02E. An external pull-up resistor is required to move the base I/O address for configuration to 0x04E.

Note 2.8 The LED pins are powered by VTR so that the LEDs can be controlled when the part is under VTR power.

Note 2.9 This pin is an input into the wake-up logic that is powered by VTR. In the case of a ring indicator for a serial port, or a GPIO it will also go to VCC powered logic. This logic must be disabled when VCC=0.

Note 2.10 This analog input is backdrive protected. Although HVTR is powered by VTR, it is possible that monitored power supplies may be powered when HVTR is off.

Note 2.11 The GP53/TXD2(IRTX) pin defaults to the GPIO input function on a VTR POR and presents a tristate impedance. When VCC=0 the pin is tristate. If GP53 function is selected and VCC is power is applied, the pin reflects the current state of GP53. The GP53/TXD2(IRTX) pin is tristate when it is configured for the TXD2 (IRTX) function under various conditions detailed in [Section 8.1.1, "IR Transmit Pin," on page 93](#).

Note 2.12 These pins are multiplexed internally with the FDC I/F. When the FDC on PP mode is selected, the PP port alternate functions are used for the FDC I/F.

Datasheet

Note 2.13 The reset glue logic is only available in SCH3112, SCH3114. The serial port is only available in the SCH3116. In all the SCH311X family, GP44 -47 have schmidt trigger inputs.

Note 2.14 The pins listed here are pins used in all of the SCH311X devices.

Note 2.15 The pins listed here represent addition functionality to those pins listed in [Table 2.5](#).

Note 2.16 All logic is powered by VTR. Vcc on pin 29 is used as an indication of the presence of the VCC rail being active. All logic that requires VCC power only, is enabled only when the VCC rail is active.

User's Note:

Open-drain pins should be pulled-up externally to supply shown in the power well column. All other pins are driven under the power well shown.

- NOMENCLATURE:

No Gate indicates that the pin is not protected, or affected by VCC=0 operation

Gate indicates that the pin is protected as an input (if required) or set to a HI-Z state as an output (if required)

In these columns, information is given in order of pin function: e.g. 1st pin function / 2nd pin function

2.3 Buffer Description

[Table 2.8](#) lists the buffers that are used in this device. A complete description of these buffers can be found in TBD.

Table 2.8 Buffer Description

BUFFER	DESCRIPTION
I	Input TTL Compatible - Super I/O Block.
IL	Input, Low Leakage Current.
I _M	Input - Hardware Monitoring Block.
I _{AN}	Analog Input, Hardware Monitoring Block.
I _{ANP}	Back Bias Protected Analog Input, Hardware Monitoring Block.
I _{AND-}	Remote Thermal Diode (current sink) Negative Input
I _{AND+}	Remote Thermal Diode (current source) Positive Input
IS	Input with Schmitt Trigger.
I_VID	Input. See DC Characteristics Section.
I _M OD3	Input/Output (Open Drain), 3mA sink.
I _M O3	Input/Output, 3mA sink, 3mA source.
O6	Output, 6mA sink, 3mA source.
O8	Output, 8mA sink, 4mA source.
OD8	Open Drain Output, 8mA sink.
IO8	Input/Output, 8mA sink, 4mA source.
IOD8	Input/Open Drain Output, 8mA sink, 4mA source.

Table 2.8 Buffer Description (continued)

BUFFER	DESCRIPTION
IS/O8	Input with Schmitt Trigger/Output, 8mA sink, 4mA source.
O12	Output, 12mA sink, 6mA source.
OD12	Open Drain Output, 12mA sink.
OD4	Open Drain Output, 4mA sink.
IO12	Input/Output, 12mA sink, 6mA source.
IOD12	Input/Open Drain Output, 12mA sink, 6mA source.
OD14	Open Drain Output, 14mA sink.
OP14	Output, 14mA sink, 14mA source.
OD_PH	Input/Output (Open Drain), See DC Electrical Characteristics on page 339
IOP14	Input/Output, 14mA sink, 14mA source. Backdrive protected.
IO16	Input/Output 16mA sink.
IOD16	Input/Output (Open Drain), 16mA sink.
PCI_IO	Input/Output. These pins must meet the PCI 3.3V AC and DC Characteristics. (Note 1)
PCI_O	Output. These pins must meet the PCI 3.3V AC and DC Characteristics.
PCI_I	Input. These pins must meet the PCI 3.3V AC and DC Characteristics.
PCI_ICLK	Clock Input. These pins must meet the PCI 3.3V AC and DC Characteristics and timing.
nSW	n Channel Switch ($R_{on} \sim 25$ Ohms)
ISPU_400	Input with 400mV Schmitt Trigger and 30uA Integrated Pull-Up.
ISPU	Input with Schmitt Trigger and Integrated Pull-Up.

Note 2.17 See the “PCI Local Bus Specification,” Revision 2.1, Section 4.2.2.

Note 2.18 See the “PCI Local Bus Specification,” Revision 2.1, Section 4.2.2 and 4.2.3.

Chapter 3 Block Diagram

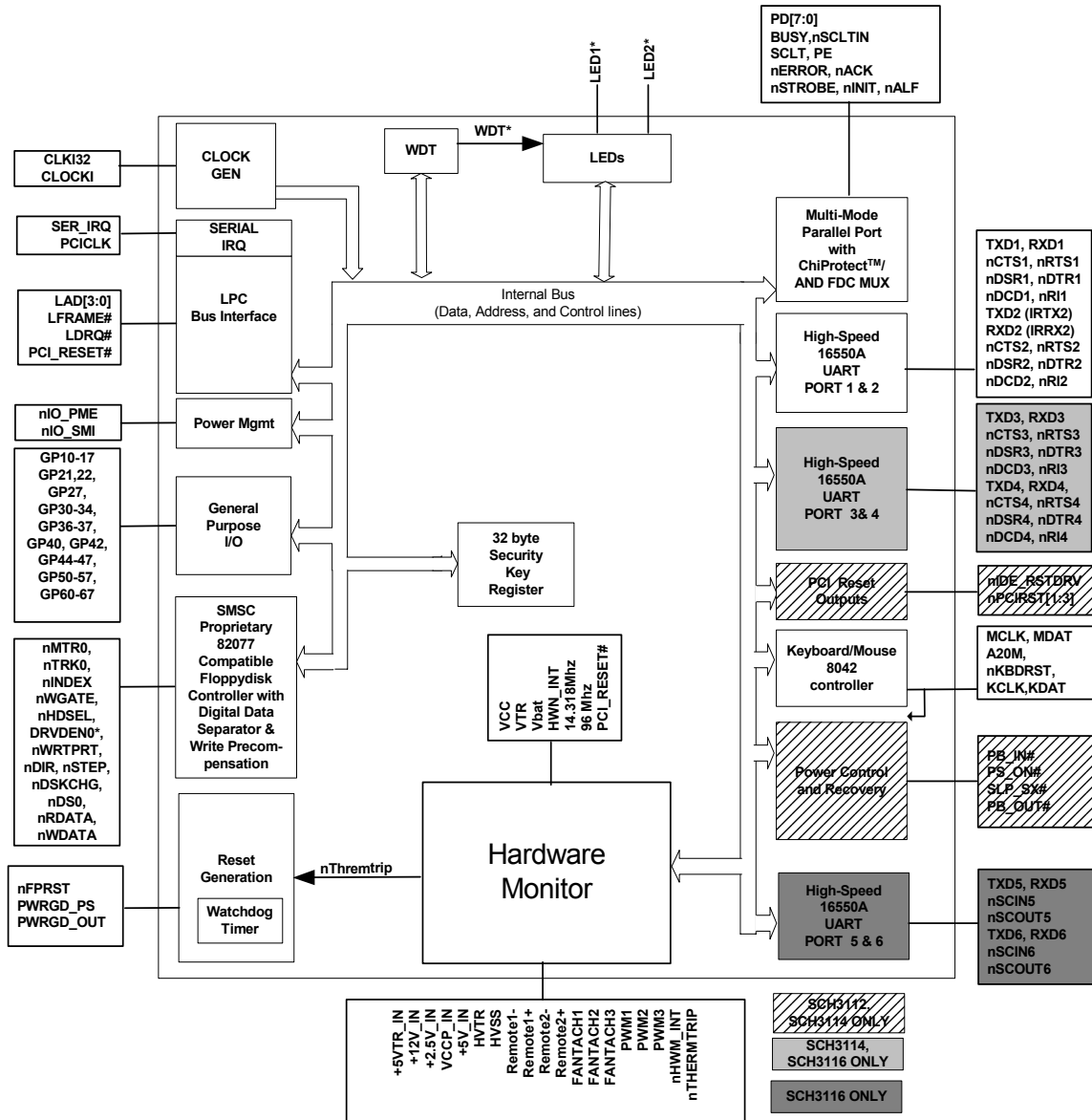

Figure 3.1 SCH311X Block Diagram



Chapter 4 Power Functionality

The SCH311X has five power planes: VCC, HVTR, VREF, VTR, and Vbat.

4.1 VCC Power

The SCH311X is a 3.3 Volt part. The VCC supply is 3.3 Volts (nominal). VCC is the main power supply for the Super I/O Block. See [Section 28.2, "DC Electrical Characteristics," on page 339](#).

4.2 HVTR Power

The SCH311X is family of 3.3 Volt devices. The HVTR supply is 3.3 Volts (nominal). HVTR is a dedicated power supply for the Hardware Monitoring Block. HVTR is connected to the VTR suspend well. See [Section 28.2, "DC Electrical Characteristics," on page 339](#).

Note: The hardware monitoring logic is powered by HVTR, but only operational when VCC is on. The hardware monitoring block is connected to the suspend well to retain the programmed configuration through a sleep cycle.

4.3 3 Volt Operation / 5 Volt Tolerance

The SCH311X is a 3.3-Volt part. It is intended solely for 3.3V applications. Non-LPC bus pins are 5V tolerant; that is, the operating input voltage is 5.5V Max, and the I/O buffer output pads are backdrive protected (they do not impose a load on any external VCC powered circuitry). The 5V tolerant pins are applicable to the Super I/O Block only.

The LPC interface pins are 3.3 V only. These signals meet PCI DC specifications for 3.3V signaling. These pins are:

- LAD[3:0]
- LFRAME#
- LDRQ#

The input voltage for all other pins is 5.5V max. These pins include all non-LPC Bus pins and the following pins in the Super I/O Block:

- PCI_RESET#
- PCI_CLK
- SER_IRQ
- nIO_PME

The Hardware Monitoring Block digital pins are 3.3V only.

4.4 VTR Support

The SCH311X requires a trickle supply (VTR) to provide sleep current for the programmable wake-up events in the PME interface when VCC is removed. The VTR supply is 3.3 Volts (nominal). See [Chapter 28, "Operational Description," on page 339](#). The maximum VTR current that is required depends on the functions that are used in the part. See [Chapter 28, "Operational Description," on page 339](#).

If the SCH311X is not intended to provide wake-up capabilities on standby current, VTR can be connected to VCC. VTR powers the IR interface, the PME configuration registers, and the PME interface. The VTR pin generates a VTR Power-on-Reset signal to initialize these components. If VTR is to be used for programmable wake-up events when VCC is removed, VTR must be at its full

minimum potential at least 10 ms before Vcc begins a power-on cycle. Note that under all circumstances, the hardware monitoring HVTR must be driven as the same source as VTR.

4.4.1 Trickle Power Functionality

When the SCH311X is running under VTR only (VCC removed), PME wakeup events are active and (if enabled) able to assert the nIO_PME pin active low. (See PME_STS1.)

The following requirements apply to all I/O pins that are specified to be 5 volt tolerant.

- I/O buffers that are wake-up event compatible are powered by VCC. Under VTR power (VCC=0), these pins may only be configured as inputs. These pins have input buffers into the wakeup logic that are powered by VTR.
- I/O buffers that may be configured as either push-pull or open drain under VTR power (VCC=0), are powered by VTR. This means, at a minimum, they will source their specified current from VTR even when VCC is present.

The GPIOs that are used for PME wakeup as input are GP21-GP22, GP27, GP32, GP33, GP50-GP57, GP60, GP61 (See PME_STS1.) These GPIOs function as follows (with the exception of GP60 and GP61 - see below):

- Buffers are powered by VCC, but in the absence of VCC they are backdrive protected (they do not impose a load on any external VTR powered circuitry). They are wakeup compatible as inputs under VTR power. These pins have input buffers into the wakeup logic that are powered by VTR.

All GPIOs listed above are PME wakeup as a GPIO (or alternate function).

GP32 and GP33 revert to their non-inverting GPIO input function when VCC is removed from the part.

The other GPIOs function as follows:

GP36, GP37 and GP40:

- Buffers are powered by VCC. In the absence of VCC they are backdrive protected. These pins do not have input buffers into the wakeup logic that are powered by VTR, and are not used for wakeup.

GP42, GP60 and GP61:

- Buffers powered by VTR. GP42 are the nIO_PME pin which is active under VTR. GP60 and GP61 have LED as the alternate function and the logic is able to control the pin under VTR.

The following list summarizes the blocks, registers and pins that are powered by VTR.

- PME interface block
- PME runtime register block (includes all PME, SMI, GPIO, Fan and other miscellaneous registers)
- Digital logic in the Hardware Monitoring block
- "Wake on Specific Key" logic
- LED control logic
- Watchdog Timer
- Power Recovery Logic
- Pins for PME Wakeup:
 - GP42/nIO_PME (output, buffer powered by VTR)
 - CLOCKI32 (input, buffer powered by VTR)
 - nRI1 (input)
 - GP50/nRI2 (input)
 - GP52/RXD2(IRRX) (input)
 - KDAT/GP21 (input)
 - MDAT/GP32 (input)

Datasheet

GPIOs (GP21-GP22, GP27, GP32, GP33, GP50-GP57, GP60, GP61) – all input-only except GP60, GP61. See below.

- Other Pins
 - GP60/LED1 (output, buffer powered by VTR)
 - GP61/LED2 (output, buffer powered by VTR)
 - nRSMRST
 - PWRGD_PS
 - PB_IN#
 - PB_OUT#
 - PS_ON#
 - nFPRST
 - SLP_SX#
 - PWRGD_OUT

4.5 Vbat Support

Vbat is a battery generated power supply that is needed to support the power recovery logic. The power recovery logic is used to restore power to the system in the event of a power failure. Power may be returned to the system by a keyboard power button, the main power button, or by the power recovery logic following an unexpected power failure.

The Vbat supply is 3.0 Volts (nominal). See [Chapter 28, "Operational Description," on page 339](#).

The following Runtime Registers are powered by Vbat:

- Bank 2 of the Runtime Register block used for the 32kbyte Security Key register
- PME_EN7 at offset 10h
- PWR_REC Register at offset 49h
- PS_ON Register at offset 4Ah
- PS_ON Previous State Register at offset 53h
- DBLCLICK register at offset 5Bh
- Keyboard Scan Code – Make Byte 1 at offset 5Fh
- Keyboard Scan Code – Make Byte 2 at offset 60h
- Keyboard Scan Code – Break Byte 1 at offset 61h
- Keyboard Scan Code – Break Byte 2 at offset 62h
- Keyboard Scan Code – Break Byte 3 at offset 63h
- Keyboard PWRBTN/SPEKEY at offset 64h

Note: All Vbat powered pins and registers are powered by VTR when VTR power is on and are battery backed-up when VTR is removed.

4.6 32.768 KHz Trickle Clock Input

The SCH311X utilizes a 32.768 KHz trickle input to supply a clock signal for the WDT, LED blink, Power Recovery Logic, and wake on specific key function.

Indication of 32KHZ Clock

There is a bit to indicate whether or not the 32KHz clock input is connected to the SCH311X. This bit is located at bit 0 of the CLOCKI32 register at 0xF0 in Logical Device A. This register is powered by VTR and reset on a VTR POR.

Bit[0] (CLK32_PRSN) is defined as follows:

0=32KHz clock is connected to the CLKI32 pin (default)

1=32KHz clock is not connected to the CLKI32 pin (pin is grounded).

Bit 0 controls the source of the 32KHz (nominal) clock for the LED blink logic and the “wake on specific key” logic. When the external 32KHz clock is connected, that will be the source for the fan, LED and “wake on specific key” logic. When the external 32KHz clock is not connected, an internal 32KHz clock source will be derived from the 14MHz clock for the LED and “wake on specific key” logic.

The following functions will not work under VTR power (VCC removed) if the external 32KHz clock is not connected. These functions will work under VCC power even if the external 32 KHz clock is not connected.

- Wake on specific key
- LED blink
- Power Recovery Logic
- WDT
- Front Panel Reset with Input Debounce, Power Supply Gate, and CPU Powergood Signal Generation

4.7 Super I/O Functions

The maximum VTR current, I_{TR} , is given with all outputs open (not loaded), and all inputs in a fixed state (i.e., 0V or 3.3V). The total maximum current for the part is the unloaded value PLUS the maximum current sourced by the pin that is driven by VTR. The super I/O pins that are powered by VTR are as follows: GP42/nIO_PME, GP60/LED1, GP61/LED2, PWRGD_OUT, and CLKI32. These pins, if configured as push-pull outputs, will source a minimum of 6mA at 2.4V when driving.

The maximum VCC current, I_{CC} , is given with all outputs open (not loaded) and all inputs in a fixed state (i.e., 0V or 3.3V).

The maximum Vbat current, I_{bat} , is given with all outputs open (not loaded) and all inputs in a fixed state (i.e., 0V or 3.3V).

4.8 Power Management Events (PME/SCI)

The SCH311X offers support for Power Management Events (PMEs), also referred to as System Control Interrupt (SCI) events. The terms PME and SCI are used synonymously throughout this document to refer to the indication of an event to the chipset via the assertion of the nIO_PME output signal. See the [Chapter 15, "PME Support," on page 153](#) section.

Chapter 5 SIO Overview

The SCH311X is a Super I/O Device with hardware monitoring. The Super I/O features are implemented as logical devices accessible through the LPC interface. The Super I/O blocks are powered by VCC, VTR, or Vbat. The Hardware Monitoring block is powered by HVTR and is accessible via the LPC interface. The following chapters define each of the functional blocks implemented in the SCH311X, their corresponding registers, and physical characteristics.

This chapter offers an introduction into the Super I/O functional blocks, registers and host interface. Details regarding the hardware monitoring block are defined in later chapters. The block diagram in PME_STS1 further details the layout of the device. Note that the Super I/O registers are implemented as typical Plug-and-Play components.

5.1 Super I/O Registers

The address map, shown below in [Table 5.1](#) shows the addresses of the different blocks of the Super I/O immediately after power up. The base addresses of all the Super I/O Logical Blocks, including the configuration register block, can be moved or relocated via the configuration registers.

Note: Some addresses are used to access more than one register.

5.2 Host Processor Interface (LPC)

The host processor communicates with the Super I/O features in the SCH311X through a series of read/write registers via the LPC interface. The port addresses for these registers are shown in [Table 5.1, "Super I/O Block Addresses"](#). Register access is accomplished through I/O cycles or DMA transfers. All registers are 8 bits wide.

Table 5.1 Super I/O Block Addresses

ADDRESS	BLOCK NAME	LOGICAL DEVICE	NOTES
Base+(0-5) and +(7)	Floppy Disk	0	
na	Reserved	1	(Note 5.5)
na	Reserved	2	(Note 5.5)
Base+(0-3) Base+(0-7) Base+(0-3), +(400-402) Base+(0-7), +(400-402)	Parallel Port SPP EPP ECP ECP+EPP+SPP	3	
Base+(0-7)	Serial Port Com 1	4	
Base+(0-7)	Serial Port Com 2	5	
na	Reserved	6	
60, 64	KYBD	7	
na	Reserved	8,9	
Base1 + (0-7F) Base2 + (0-1F)	Runtime Registers Security Key Registers	A	(Note 5.2)
Base+(0-7)	Serial Port Com 3	B	(Note 5.3)

Table 5.1 Super I/O Block Addresses (continued)

ADDRESS	BLOCK NAME	LOGICAL DEVICE	NOTES
Base+(0-7)	Serial Port Com 4	C	Note 5.3
Base+(0-7)	Serial Port Com 5	D	Note 5.3 , Note 5.4
Base+(0-7)	Serial Port Com 6	E	Note 5.3 , Note 5.4
na	Reserved	F	
Base + (0-1)	Configuration		(Note 5.1)

Note 5.1 Refer to the configuration register descriptions for setting the base address.

Note 5.2 Logical Device A is referred to as the Runtime Register block at Base1 or PME Block and may be used interchangeably throughout this document.

Note 5.3 Reserved in SCH3112 Device

Note 5.4 Reserved in SCH3114 Device

Note 5.5 na = not applicable

Chapter 6 LPC Interface

6.1 LPC Interface Signal Definition

The signals implemented for the LPC bus interface are described in the tables below. LPC bus signals use PCI 33MHz electrical signal characteristics.

6.1.1 LPC Required Signals

SIGNAL NAME	TYPE	DESCRIPTION
LAD[3:0]	I/O	LPC address/data bus. Multiplexed command, address and data bus.
LFRAME#	Input	Frame signal. Indicates start of new cycle and termination of broken cycle
PCI_RESET#	Input	PCI Reset. Used as LPC Interface Reset. Same functionality as RST_DRV but active low 3.3V.
PCI_CLK	Input	PCI Clock.

6.1.2 LPC Optional Signals

SIGNAL NAME	TYPE	DESCRIPTION	COMMENT
LDRQ#	Output	Encoded DMA/Bus Master request for the LPC interface.	Implemented
SER_IRQ	I/O	Serial IRQ.	Implemented
CLKRUN#	OD	Clock Run	Not Implemented
nIO_PME	OD	Same as the PME# or Power Mgt Event signal. Allows the SCH311X to request wakeup in S3 and below.	Implemented
LPCPD#	I	Power down - Indicates that the device should prepare for LPC I/F shutdown	Not Implemented
LSMI#	OD	Only need for SMI# generation on I/O instruction for retry.	Not Implemented

6.2 Supported LPC Cycles

Table 6.1 summarizes the cycle types are supported by the SCH311X. All other cycle types are ignored.

Table 6.1 Supported LPC Cycles

CYCLE TYPE	TRANSFER SIZE	COMMENT
I/O Write	1 Byte	Supported
I/O Read	1 Byte	Supported
Memory Write	1 Byte	Not Supported
Memory Read	1 Byte	Not Supported

Table 6.1 Supported LPC Cycles (continued)

CYCLE TYPE	TRANSFER SIZE	COMMENT
DMA Write	1 Byte	Supported
DMA Write	2 Byte	Supported
DMA Write	4 Byte	Not Supported
DMA Read	1 Byte	Supported
DMA Read	2 Byte	Supported
DMA Read	4 Byte	Not Supported
Bus Master Memory Write	1 Byte	Not Supported
Bus Master Memory Write	2 Byte	Not Supported
Bus Master Memory Write	4 Byte	Not Supported
Bus Master Memory Read	1 Byte	Not Supported
Bus Master Memory Read	2 Byte	Not Supported
Bus Master Memory Read	4 Byte	Not Supported
Bus Master I/O Write	1 Byte	Not Supported
Bus Master I/O Write	2 Byte	Not Supported
Bus Master I/O Write	4 Byte	Not Supported
Bus Master I/O Read	1 Byte	Not Supported
Bus Master I/O Read	2 Byte	Not Supported
Bus Master I/O Read	4 Byte	Not Supported

6.3 Device Specific Information

The LPC interface conforms to the “*Low Pin Count (LPC) Interface Specification*”. The following section will review any implementation specific information for this device.

6.3.1 SYNC Protocol

The SYNC pattern is used to add wait states. For read cycles, the SCH311X immediately drives the SYNC pattern upon recognizing the cycle. The host immediately drives the sync pattern for write cycles. If the SCH311X needs to assert wait states, it does so by driving 0101 or 0110 on LAD[3:0] until it is ready, at which point it will drive 0000 or 1001. The SCH311X will choose to assert 0101 or 0110, but not switch between the two patterns.

The data (or wait state SYNC) will immediately follow the 0000 or 1001 value. The SYNC value of 0101 is intended to be used for normal wait states, wherein the cycle will complete within a few clocks. The SCH311X uses a SYNC of 0101 for all wait states in a DMA transfer.

The SYNC value of 0110 is intended to be used where the number of wait states is large. This is provided for EPP cycles, where the number of wait states could be quite large (>1 microsecond). However, the SCH311X uses a SYNC of 0110 for all wait states in an I/O transfer.

The SYNC value is driven within 3 clocks.

Datasheet

6.3.2 Reset Policy

The following rules govern the reset policy:

- When PCI_RESET# goes inactive (high), the PCI clock is assumed to have been running for 100usec prior to the removal of the reset signal, so that everything is stable. This is the same reset active time after clock is stable that is used for the PCI bus.
- When PCI_RESET# goes active (low):
 1. The host drives the LFRAME# signal high, tristates the LAD[3:0] signals, and ignores the LDRQ# signal.
 2. The SCH311X ignores LFRAME#, tristates the LAD[3:0] pins and drives the LDRQ# signal inactive (high).



Chapter 7 Floppy Disk Controller

The Floppy Disk controller (FDC) provides the interface between a host microprocessor and the floppy disk drives. The FDC integrates the functions of the Formatter/Controller, Digital Data Separator, Write Precompensation and Data Rate Selection logic for an IBM XT/AT compatible FDC. The true CMOS 765B core guarantees 100% IBM PC XT/AT compatibility in addition to providing data overflow and underflow protection. SCH311X supports a single floppy disk drive.

The FDC is compatible to the 82077AA using SMSC's proprietary floppy disk controller core.

7.1 FDC Internal Registers

The Floppy Disk Controller contains eight internal registers which facilitate the interfacing between the host microprocessor and the disk drive. [Table 7.1](#) shows the addresses required to access these registers. Registers other than the ones shown are not supported. The rest of the description assumes that the primary addresses have been selected.

(Shown with base addresses of 3F0 and 370)

Table 7.1 Status, Data and Control Registers

PRIMARY ADDRESS	SECONDARY ADDRESS	R/W	REGISTER
3F0	370	R	Status Register A (SRA)
3F1	371	R	Status Register B (SRB)
3F2	372	R/W	Digital Output Register (DOR)
3F3	373	R/W	Tape Drive Register (TDR)
3F4	374	R	Main Status Register (MSR)
3F4	374	W	Data Rate Select Register (DSR)
3F5	375	R/W	Data (FIFO)
3F6	376		Reserved
3F7	377	R	Digital Input Register (DIR)
3F7	377	W	Configuration Control Register (CCR)

7.1.1 Status Register A (SRA)

Address 3F0 READ ONLY

This register is read-only and monitors the state of the internal interrupt signal and several disk interface pins in PS/2 and Model 30 modes. The SRA can be accessed at any time when in PS/2 mode. In the PC/AT mode the data bus pins D0 – D7 are held in a high impedance state for a read of address 3F0.

PS/2 MODE

	7	6	5	4	3	2	1	0
	INT PENDING	nDRV2	STEP	nTRK0	HDSEL	nINDX	nWP	DIR
RESET COND.	0	1	0	N/A	0	N/A	N/A	0

Bit 0 DIRECTION

Active high status indicating the direction of head movement. A logic “1” indicates inward direction; a logic “0” indicates outward direction.

Bit 1 nWRITE PROTECT

Active low status of the WRITE PROTECT disk interface input. A logic “0” indicates that the disk is write protected.

Bit 2 nINDEX

Active low status of the INDEX disk interface input.

Bit 3 HEAD SELECT

Active high status of the HDSEL disk interface input. A logic “1” selects side 1 and a logic “0” selects side 0.

Bit 4 nTRACK 0

Active low status of the TRK0 disk interface input.

Bit 5 STEP

Active high status of the STEP output disk interface output pin.

Bit 6 nDRV2

This function is not supported. This bit is always read as “1”.

Bit 7 INTERRUPT PENDING

Active high bit indicating the state of the Floppy Disk Interrupt output.

7.1.2 PS/2 Model 30 Mode

	7	6	5	4	3	2	1	0
	INT PENDING	DRQ	STEP F/F	TRK0	nHDSEL	INDX	WP	nDIR
RESET COND.	0	0	0	N/A	1	N/A	N/A	1

Bit 0 DIRECTION

Active low status indicating the direction of head movement. A logic “0” indicates inward direction; a logic “1” indicates outward direction.

Bit 1 WRITE PROTECT

Active high status of the WRITE PROTECT disk interface input. A logic “1” indicates that the disk is write protected.

Bit 2 INDEX

Active high status of the INDEX disk interface input.

Bit 3 HEAD SELECT

Active low status of the HDSEL disk interface input. A logic “0” selects side 1 and a logic “1” selects side 0.

Datasheet**Bit 4 TRACK 0**

Active high status of the TRK0 disk interface input.

Bit 5 STEP

Active high status of the latched STEP disk interface output pin. This bit is latched with the STEP output going active, and is cleared with a read from the DIR register, or with a hardware or software reset.

Bit 6 DMA REQUEST

Active high status of the DMA request pending.

Bit 7 INTERRUPT PENDING

Active high bit indicating the state of the Floppy Disk Interrupt.

STATUS REGISTER B (SRB)**Address 3F1 READ ONLY**

This register is read-only and monitors the state of several disk interface pins in PS/2 and Model 30 modes. The SRB can be accessed at any time when in PS/2 mode. In the PC/AT mode the data bus pins D0 – D7 are held in a high impedance state for a read of address 3F1.

PS/2 MODE

	7	6	5	4	3	2	1	0
	Reserved	Reserved	DRIVE SELO	WDATA TOGGLE	RDATA TOGGLE	WGATE	Reserved	MOT EN0
RESET COND.	1	1	0	0	0	0	0	0

Bit 0 MOTOR ENABLE 0

Active high status of the MTR0 disk interface output pin. This bit is low after a hardware reset and unaffected by a software reset.

Bit 1 Reserved

Reserved will return a zero (0) when read. This bit is low after a hardware reset and unaffected by a software reset.

Bit 2 WRITE GATE

Active high status of the WGATE disk interface output.

Bit 3 READ DATA TOGGLE

Every inactive edge of the RDATA input causes this bit to change state.

Bit 4 WRITE DATA TOGGLE

Every inactive edge of the WDATA input causes this bit to change state.

Bit 5 DRIVE SELECT 0

Reflects the status of the Drive Select 0 bit of the DOR (address 3F2 bit 0). This bit is cleared after a hardware reset and it is unaffected by a software reset.

Bit 6 RESERVED

Always read as a logic “1”.

Bit 7 RESERVED

Always read as a logic “1”.

PS/2 MODEL 30 MODE

	7	6	5	4	3	2	1	0
	nDRV2	nDS1	nDS0	WDATA F/F	RDATA F/F	WGATE F/F	nDS3	nDS2
RESET COND.	N/A	1	1	0	0	0	1	1

Bit 0 nDRIVE SELECT 2

The DS2 disk interface is not supported.

Bit 1 nDRIVE SELECT 3

The DS3 disk interface is not supported.

Bit 2 WRITE GATE

Active high status of the latched WGATE output signal. This bit is latched by the active going edge of WGATE and is cleared by the read of the DIR register.

Bit 3 READ DATA

Active high status of the latched RDATA output signal. This bit is latched by the inactive going edge of RDATA and is cleared by the read of the DIR register.

Bit 4 WRITE DATA

Active high status of the latched WDATA output signal. This bit is latched by the inactive going edge of WDATA and is cleared by the read of the DIR register. This bit is not gated with WGATE.

Bit 5 nDRIVE SELECT 0

Active low status of the DS0 disk interface output.

Bit 6 nDRIVE SELECT 1

The DS 1 disk interface is not supported.

Bit 7 nDRV2

Active low status of the DRV2 disk interface input. Note: This function is not supported.

DIGITAL OUTPUT REGISTER (DOR)
Address 3F2 READ/WRITE

The DOR controls the drive select and motor enables of the disk interface outputs. It also contains the enable for the DMA logic and a software reset bit. The contents of the DOR are unaffected by a software reset. The DOR can be written to at any time.

Datasheet

	7	6	5	4	3	2	1	0
	MOT EN3	MOT EN2	MOT EN1	MOT EN0	DMAEN	nRESET	DRIVE SEL1	DRIVE SEL0
RESET COND.	0	0	0	0	0	0	0	0

Bit 0 and 1 DRIVE SELECT

These two bits are binary encoded for the drive selects, thereby allowing only one drive to be selected at one time. For proper device operation, they must be programmed to 0b00.

Bit 2 nRESET

A logic "0" written to this bit resets the Floppy disk controller. This reset will remain active until a logic "1" is written to this bit. This software reset does not affect the DSR and CCR registers, nor does it affect the other bits of the DOR register. The minimum reset duration required is 100ns, therefore toggling this bit by consecutive writes to this register is a valid method of issuing a software reset.

Bit 3 DMAEN

PC/AT and Model 30 Mode:

Writing this bit to logic "1" will enable the DMA and interrupt functions. This bit being a logic "0" will disable the DMA and interrupt functions. This bit is a logic "0" after a reset and in these modes.

PS/2 Mode: In this mode the DMA and interrupt functions are always enabled. During a reset, this bit will be cleared to a logic "0".

Bit 4 MOTOR ENABLE 0

This bit controls the MTR0 disk interface output. A logic "1" in this bit will cause the output pin to go active.

Bit 5 MOTOR ENABLE 1

The MTR1 disk interface output is not support in the LPC5M262. For proper device operation this bit must be programmed with a zero (0).

DRIVE	DOR VALUE
0	1CH

Table 7.2 Internal 2 Drive Decode – Normal

DIGITAL OUTPUT REGISTER			DRIVE SELECT OUTPUTS (ACTIVE LOW)	MOTOR ON OUTPUTS (ACTIVE LOW)
Bit 4	Bit1	Bit 0	nDS0	nMTR0
1	0	0	0	nBIT 4
X	1	0	1	nBIT 4
X	X	1	1	nBIT 4

Bit 6 MOTOR ENABLE 2

The MTR2 disk interface output is not supported in the SCH311X.

Bit 7 MOTOR ENABLE 3

The MTR3 disk interface output is not supported in the SCH311X.

TAPE DRIVE REGISTER (TDR)
Address 3F3 READ/WRITE

The Tape Drive Register (TDR) is included for 82077 software compatibility and allows the user to assign tape support to a particular drive during initialization. Any future references to that drive automatically invokes tape support. The TDR Tape Select bits TDR.[1:0] determine the tape drive number. [Table 7.3](#) illustrates the Tape Select Bit encoding. Note that drive 0 is the boot device and cannot be assigned tape support. The remaining Tape Drive Register bits TDR.[7:2] are tristated when read. The TDR is unaffected by a software reset.

Table 7.3 Tape Select Bits

TAPE SEL1 (TDR.1)	TAPE SEL0 (TDR.0)	DRIVE SELECTED
0	0	None
0	1	1 (not supported)
1	0	2 (not supported)
1	1	3 (not supported)

APPLICATION NOTE: Note that in this device since only drive 0 is supported, the tape sel0/1 bits must be set to 0b00 for proper operation.

NORMAL FLOPPY MODE

Normal mode. Register 3F3 contains only bits 0 and 1. When this register is read, bits 2 – 7 are '0'

Note only drive 0 is supported.

	DB7	DB6	DB5	DB4	DB3	DB2	DB1	DB0
REG 3F3	0	0	0	0	0	0	tape sel1	tape sel0

ENHANCED FLOPPY MODE 2 (OS2)

Register 3F3 for Enhanced Floppy Mode 2 operation.

Note only drive 0 is supported

	DB7	DB6	DB5	DB4	DB3	DB2	DB1	DB0
REG 3F3	Reserved	Reserved	Drive Type ID		Floppy Boot Drive		tape sel1	tape sel0

Table 7.4 Drive Type ID

DIGITAL OUTPUT REGISTER		REGISTER 3F3 – DRIVE TYPE ID	
Bit 1	Bit 0	Bit 5	Bit 4
0	0	L0-CRF2 – B1	L0-CRF2 – B0
0	1	L0-CRF2 – B3	L0-CRF2 – B2
1	0	L0-CRF2 – B5	L0-CRF2 – B4
1	1	L0-CRF2 – B7	L0-CRF2 – B6

Note: L0-CRF2-Bx = Logical Device 0, Configuration Register F2, Bit x.

DATA RATE SELECT REGISTER (DSR)

Address 3F4 WRITE ONLY

This register is write only. It is used to program the data rate, amount of write precompensation, power down status, and software reset. The data rate is programmed using the Configuration Control Register (CCR) not the DSR, for PC/AT and PS/2 Model 30.

	7	6	5	4	3	2	1	0
	S/W RESET	POWER DOWN	0	PRE- COMP2	PRE- COMP1	PRE- COMP0	DRATE SEL1	DRATE SEL0
RESET COND.	0	0	0	0	0	0	1	0

This register is write only. It is used to program the data rate, amount of write precompensation, power down status, and software reset. The data rate is programmed using the Configuration Control Register (CCR) not the DSR, for PC/AT and PS/2 Model 30.

Other applications can set the data rate in the DSR. The data rate of the floppy controller is the most recent write of either the DSR or CCR. The DSR is unaffected by a software reset. A hardware reset will set the DSR to 02H, which corresponds to the default precompensation setting and 250 Kbps.

Bit 0 and 1 DATA RATE SELECT

These bits control the data rate of the floppy controller. See [Table 7.6](#) for the settings corresponding to the individual data rates. The data rate select bits are unaffected by a software reset, and are set to 250 Kbps after a hardware reset.

Bit 2 through 4 PRECOMPENSATION SELECT

These three bits select the value of write precompensation that will be applied to the WDATA output signal. [Table 7.5](#) shows the precompensation values for the combination of these bits settings. Track 0 is the default starting track number to start precompensation. This starting track number can be changed by the configure command.

Table 7.5 Precompensation Delays

PRECOMP 432	PRECOMPENSATION DELAY (NSEC)	
	<2Mbps	2Mbps
111	0.00	0
001	41.67	20.8
010	83.34	41.7
011	125.00	62.5
100	166.67	83.3
101	208.33	104.2
110	250.00	125
000	Default	Default

Default: See [Table 7.8 on page 43](#).

Bit 5 UNDEFINED

Should be written as a logic "0".

Bit 6 LOW POWER

A logic "1" written to this bit will put the floppy controller into manual low power mode. The floppy controller clock and data separator circuits will be turned off. The controller will come out of manual low power mode after a software reset or access to the Data Register or Main Status Register.

Bit 7 SOFTWARE RESET

This active high bit has the same function as the DOR RESET (DOR bit 2) except that this bit is self clearing.

Note: The DSR is Shadowed in the Floppy Data Rate Select Shadow Register, located at the offset 0x1F in the runtime register block Separator circuits will be turned off. The controller will come out of manual low power.

Table 7.6 Data Rates

DRIVE RATE		DATA RATE		DATA RATE		DENSEL	DRATE(1)	
DRT1	DRT0	SEL1	SEL0	MFM	FM		1	0
0	0	1	1	1Meg	---	1	1	1
0	0	0	0	500	250	1	0	0
0	0	0	1	300	150	0	0	1
0	0	1	0	250	125	0	1	0
0	1	1	1	1Meg	---	1	1	1
0	1	0	0	500	250	1	0	0
0	1	0	1	500	250	0	0	1
0	1	1	0	250	125	0	1	0
1	0	1	1	1Meg	---	1	1	1
1	0	0	0	500	250	1	0	0
1	0	0	1	2Meg	---	0	0	1

Datasheet

Table 7.6 Data Rates (continued)

DRIVE RATE		DATA RATE		DATA RATE		DENSEL	DRATE(1)	
1	0	1	0	250	125	0	1	0

Drive Rate Table (Recommended) 00 = 360K, 1.2M, 720K, 1.44M and 2.88M Vertical Format

01 = 3-Mode Drive

10 = 2 Meg Tape

Note: The DRATE and DENSEL values are mapped onto the DRVDEN pins.

Table 7.7 DRVDEN Mapping

DT1	DT0	DRVDEN1 (1)	DRVDEN0 (1)	DRIVE TYPE
0	0	DRATE0	DENSEL	4/2/1 MB 3.5" 2/1 MB 5.25" FDDS 2/1.6/1 MB 3.5" (3-MODE)
1	0	DRATE0	DRATE1	
0	1	DRATE0	nDENSEL	PS/2
1	1	DRATE1	DRATE0	

Table 7.8 Default Precompensation Delays

DATA RATE	PRECOMPENSATION DELAYS
2 Mbps 1 Mbps 500 Kbps 300 Kbps 250 Kbps	20.8 ns 41.67 ns 125 ns 125 ns 125 ns

MAIN STATUS REGISTER**Address 3F4 READ ONLY**

The Main Status Register is a read-only register and indicates the status of the disk controller. The Main Status Register can be read at any time. The MSR indicates when the disk controller is ready to receive data via the Data Register. It should be read before each byte transferring to or from the data register except in DMA mode. No delay is required when reading the MSR after a data transfer.

7	6	5	4	3	2	1	0
RQM	DIO	NON DMA	CMD BUSY	Reserved	Reserved	Reserved	DRV0 BUSY

Bit 0 DRV0 BUSY

This bit is set to 1 when a drive is in the seek portion of a command, including implied and overlapped seeks and re calibrates.

BIT 1 RESERVED

Reserved - read returns 0

Bit 4 COMMAND BUSY

This bit is set to a 1 when a command is in progress. This bit will go active after the command byte has been accepted and goes inactive at the end of the results phase. If there is no result phase (Seek, Re calibrate commands), this bit is returned to a 0 after the last command byte.

Bit 5 NON-DMA

Reserved, read '0'. This part does not support non-DMA mode.

Bit 6 DIO

Indicates the direction of a data transfer once a RQM is set. A 1 indicates a read and a 0 indicates a write is required.

Bit 7 RQM

Indicates that the host can transfer data if set to a 1. No access is permitted if set to a 0.

DATA REGISTER (FIFO)**Address 3F5 READ/WRITE**

All command parameter information, disk data and result status are transferred between the host processor and the floppy disk controller through the Data Register.

Data transfers are governed by the RQM and DIO bits in the Main Status Register.

The Data Register defaults to FIFO disabled mode after any form of reset. This maintains PC/AT hardware compatibility. The default values can be changed through the Configure command (enable full FIFO operation with threshold control). The advantage of the FIFO is that it allows the system a larger DMA latency without causing a disk error. [Table 7.9](#) gives several examples of the delays with a FIFO.

The data is based upon the following formula:

$$\text{DELAY} = \text{Fifo Threshold \#} \times \text{DATA RATE} \times 8 - 1.5 \mu\text{s}$$

At the start of a command, the FIFO action is always disabled and command parameters must be sent based upon the RQM and DIO bit settings. As the command execution phase is entered, the FIFO is cleared of any data to ensure that invalid data is not transferred.

An overrun or underrun will terminate the current command and the transfer of data. Disk writes will complete the current sector by generating a 00 pattern and valid CRC. Reads require the host to remove the remaining data so that the result phase may be entered.

Table 7.9 FIFO Service Delay

FIFO THRESHOLD EXAMPLES	MAXIMUM DELAY TO SERVICING AT 2 MBPS DATA RATE
1 byte 2 bytes 8 bytes 15 bytes	1 x 4 μ S - 1.5 μ S = 2.5 μ S 2 x 4 μ S - 1.5 μ S = 6.5 μ S 8 x 4 μ S - 1.5 μ S = 30.5 μ S 15 x 4 μ S - 1.5 μ S = 58.5 μ S
FIFO THRESHOLD EXAMPLES	MAXIMUM DELAY TO SERVICING AT 1 MBPS DATA RATE
1 byte 2 bytes 8 bytes 15 bytes	1 x 8 μ S - 1.5 μ S = 6.5 μ S 2 x 8 μ S - 1.5 μ S = 14.5 μ S 8 x 8 μ S - 1.5 μ S = 62.5 μ S 15 x 8 μ S - 1.5 μ S = 118.5 μ S
FIFO THRESHOLD EXAMPLES	MAXIMUM DELAY TO SERVICING AT 500 Kbps DATA RATE
1 byte 2 bytes 8 bytes 15 bytes	1 x 16 μ S - 1.5 μ S = 14.5 μ S 2 x 16 μ S - 1.5 μ S = 30.5 μ S 8 x 16 μ S - 1.5 μ S = 126.5 μ S 15 x 16 μ S - 1.5 μ S = 238.5 μ S

DIGITAL INPUT REGISTER (DIR)**Address 3F7 READ ONLY**

This register is read-only in all modes.

PC-AT MODE

	7	6	5	4	3	2	1	0
	DSK CHG	0	0	0	0	0	0	0
RESET COND.	N/A	N/A	N/A	N/A	N/A	N/A	N/A	N/A

Bit 0 – 6 UNDEFINED

The data bus outputs D0 – 6 are read as '0'.

Bit 7 DSKCHG

This bit monitors the pin of the same name and reflects the opposite value seen on the disk cable or the value programmed in the Force Disk Change Register (see the Runtime Register at offset 0x1E).

PS/2 MODE

	7	6	5	4	3	2	1	0
	DSK CHG	1	1	1	1	DRATE SEL1	DRATE SEL0	nHIGH DENS
RESET COND.	N/A	N/A	N/A	N/A	N/A	N/A	N/A	1

Bit 0 nHIGH DENS

This bit is low whenever the 500 Kbps or 1 Mbps data rates are selected, and high when 250 Kbps and 300 Kbps are selected.

Bits 1 – 2 DATA RATE SELECT

These bits control the data rate of the floppy controller. See [Table 7.6 on page 42](#) for the settings corresponding to the individual data rates. The data rate select bits are unaffected by a software reset, and are set to 250 Kbps after a hardware reset.

Bits 3 – 6 UNDEFINED

Always read as a logic “1”

Bit 7 DSKCHG

This bit monitors the pin of the same name and reflects the opposite value seen on the disk cable or the value programmed in the Force Disk Change Register (see Runtime Register at offset 0x1E).

MODEL 30 MODE

	7	6	5	4	3	2	1	0
	DSK CHG	0	0	0	DMAEN	NOPREC	DRATE SEL1	DRATE SEL0
RESET COND.	N/A	0	0	0	0	0	1	0

Bits 0 – 1 DATA RATE SELECT

These bits control the data rate of the floppy controller. See [Table 7.6](#) for the settings corresponding to the individual data rates. The data rate select bits are unaffected by a software reset, and are set to 250 Kbps after a hardware reset.

Bit 2 NOPREC

This bit reflects the value of NOPREC bit set in the CCR register.

Bit 3 DMAEN

This bit reflects the value of DMAEN bit set in the DOR register bit 3.

Bits 4 – 6 UNDEFINED

Always read as a logic “0”

Bit 7 DSKCHG

This bit monitors the pin of the same name and reflects the opposite value seen on the disk cable or the value programmed in the Force Disk Change Register (see Runtime Register at offset 0x1E).

Datasheet

7.1.2.1 Configuration Control Register (CCR)

Address 3F7 WRITE ONLY

PC/AT AND PS/2 MODES

	7	6	5	4	3	2	1	0
	0	0	0	0	0	0	DRATE SEL1	DRATE SEL0
RESET COND.	N/A	N/A	N/A	N/A	N/A	N/A	1	0

Bit 0 and 1 DATA RATE SELECT 0 and 1

These bits determine the data rate of the floppy controller. See [Table 7.6 on page 42](#) for the appropriate values.

Bit 2 – 7 RESERVED

Should be set to a logical “0”

PS/2 MODEL 30 MODE

	7	6	5	4	3	2	1	0
	0	0	0	0	0	NOPREC	DRATE SEL1	DRATE SEL0
RESET COND.	N/A	N/A	N/A	N/A	N/A	N/A	1	0

Bit 0 and 1 DATA RATE SELECT 0 and 1

These bits determine the data rate of the floppy controller. See [Table 7.6 on page 42](#) for the appropriate values.

Bit 2 NO PRECOMPENSATION

This bit can be set by software, but it has no functionality. It can be read by bit 2 of the DSR when in Model 30 register mode. Unaffected by software reset.

Bit 3 – 7 RESERVED

Should be set to a logical “0”

[Table 7.7 on page 43](#) shows the state of the DENSEL pin. The DENSEL pin is set high after a hardware reset and is unaffected by the DOR and the DSR resets.

7.1.3 Status Register Encoding

During the Result Phase of certain commands, the Data Register contains data bytes that give the status of the command just executed.

Table 7.10 Status Register 0

BIT NO.	SYMBOL	NAME	DESCRIPTION
7,6	IC	Interrupt Code	00 - Normal termination of command. The specified command was properly executed and completed without error. 01 - Abnormal termination of command. Command execution was started, but was not successfully completed. 10 - Invalid command. The requested command could not be executed. 11 - Abnormal termination caused by Polling.
5	SE	Seek End	The FDC completed a Seek, Relative Seek or Recalibrate command (used during a Sense Interrupt Command).
4	EC	Equipment Check	The TRK0 pin failed to become a "1" after: 1. 80 step pulses in the Recalibrate command. 2. The Relative Seek command caused the FDC to step outward beyond Track 0.
3			Unused. This bit is always "0".
2	H	Head Address	The current head address.
1,0	DS1,0	Drive Select	The current selected drive.

Table 7.11 Status Register 1

BIT NO.	SYMBOL	NAME	DESCRIPTION
7	EN	End of Cylinder	The FDC tried to access a sector beyond the final sector of the track (255D). Will be set if TC is not issued after Read or Write Data command.
6			Unused. This bit is always "0".
5	DE	Data Error	The FDC detected a CRC error in either the ID field or the data field of a sector.
4	OR	Overflow/ Underrun	Becomes set if the FDC does not receive CPU or DMA service within the required time interval, resulting in data overrun or underrun.
3			Unused. This bit is always "0".
2	ND	No Data	Any one of the following: 1. Read Data, Read Deleted Data command - the FDC did not find the specified sector. 2. Read ID command - the FDC cannot read the ID field without an error. 3. Read A Track command - the FDC cannot find the proper sector sequence.
1	NW	Not Writable	WP pin became a "1" while the FDC is executing a Write Data, Write Deleted Data, or Format A Track command.

Datasheet

Table 7.11 Status Register 1 (continued)

BIT NO.	SYMBOL	NAME	DESCRIPTION
0	MA	Missing Address Mark	Any one of the following: 1. The FDC did not detect an ID address mark at the specified track after encountering the index pulse from the nINDEX pin twice. 2. The FDC cannot detect a data address mark or a deleted data address mark on the specified track.

Table 7.12 Status Register 2

BIT NO.	SYMBOL	NAME	DESCRIPTION
7			Unused. This bit is always "0".
6	CM	Control Mark	Any one of the following: Read Data command - the FDC encountered a deleted data address mark. Read Deleted Data command - the FDC encountered a data address mark.
5	DD	Data Error in Data Field	The FDC detected a CRC error in the data field.
4	WC	Wrong Cylinder	The track address from the sector ID field is different from the track address maintained inside the FDC.
3			Unused. This bit is always "0".
2			Unused. This bit is always "0".
1	BC	Bad Cylinder	The track address from the sector ID field is different from the track address maintained inside the FDC and is equal to FF hex, which indicates a bad track with a hard error according to the IBM soft-sectored format.
0	MD	Missing Data Address Mark	The FDC cannot detect a data address mark or a deleted data address mark.

Table 7.13 Status Register 3

BIT NO.	SYMBOL	NAME	DESCRIPTION
7			Unused. This bit is always "0".
6	WP	Write Protected	Indicates the status of the WRTprt pin.
5			Unused. This bit is always "1".
4	T0	Track 0	Indicates the status of the TRK0 pin.
3			Unused. This bit is always "1".
2	HD	Head Address	Indicates the status of the HDSEL pin.
1,0	DS1,0	Drive Select	Indicates the status of the DS1, DS0 pins.

RESET

There are three sources of system reset on the FDC: the PCI_RESET# pin, a reset generated via a bit in the DOR, and a reset generated via a bit in the DSR. At power on, a Power On Reset initializes the FDC. All resets take the FDC out of the power down state.

All operations are terminated upon a PCI_RESET#, and the FDC enters an idle state. A reset while a disk write is in progress will corrupt the data and CRC.

On exiting the reset state, various internal registers are cleared, including the Configure command information, and the FDC waits for a new command. Drive polling will start unless disabled by a new Configure command.

PCI_RESET# Pin (Hardware Reset)

The PCI_RESET# pin is a global reset and clears all registers except those programmed by the Specify command. The DOR reset bit is enabled and must be cleared by the host to exit the reset state.

DOR Reset vs. DSR Reset (Software Reset)

These two resets are functionally the same. Both will reset the FDC core, which affects drive status information and the FIFO circuits. The DSR reset clears itself automatically while the DOR reset requires the host to manually clear it. DOR reset has precedence over the DSR reset. The DOR reset is set automatically upon a pin reset. The user must manually clear this reset bit in the DOR to exit the reset state.

MODES OF OPERATION

The FDC has three modes of operation, PC/AT mode, PS/2 mode and Model 30 mode. These are determined by the state of the Interface Mode bits in LD0-CRF0[3,2].

PC/AT Mode

The PC/AT register set is enabled, the DMA enable bit of the DOR becomes valid (controls the interrupt and DMA functions), and DENSEL is an active high signal.

PS/2 Mode

This mode supports the PS/2 models 50/60/80 configuration and register set. The DMA bit of the DOR becomes a “don’t care”. The DMA and interrupt functions are always enabled, and DENSEL is active low.

Model 30 mode

This mode supports PS/2 Model 30 configuration and register set. The DMA enable bit of the DOR becomes valid (controls the interrupt and DMA functions), and DENSEL is active low.

DMA TRANSFERS

DMA transfers are enabled with the Specify command and are initiated by the FDC by activating a DMA request cycle. DMA read, write and verify cycles are supported. The FDC supports two DMA transfer modes: Single Transfer and Burst Transfer. Burst mode is enabled via Logical Device 0-CRF0-Bit[1] (LD0-CRF0[1]).

CONTROLLER PHASES

For simplicity, command handling in the FDC can be divided into three phases: Command, Execution, and Result. Each phase is described in the following sections.

Command Phase

After a reset, the FDC enters the command phase and is ready to accept a command from the host. For each of the commands, a defined set of command code bytes and parameter bytes has to be written to the FDC before the command phase is complete. (Please refer to [Table 7.14 on page 52](#) for the command set descriptions). These bytes of data must be transferred in the order prescribed.

Datasheet

Before writing to the FDC, the host must examine the RQM and DIO bits of the Main Status Register. RQM and DIO must be equal to “1” and “0” respectively before command bytes may be written. RQM is set false by the FDC after each write cycle until the received byte is processed. The FDC asserts RQM again to request each parameter byte of the command unless an illegal command condition is detected. After the last parameter byte is received, RQM remains “0” and the FDC automatically enters the next phase as defined by the command definition.

The FIFO is disabled during the command phase to provide for the proper handling of the “Invalid Command” condition.

EXECUTION PHASE

All data transfers to or from the FDC occur during the execution phase, which can proceed in DMA mode as indicated in the Specify command.

After a reset, the FIFO is disabled. Each data byte is transferred by a read/write or DMA cycle depending on the DMA mode. The Configure command can enable the FIFO and set the FIFO threshold value.

The following paragraphs detail the operation of the FIFO automatic direction control. In these descriptions, <threshold> is defined as the number of bytes available to the FDC when service is requested from the host and ranges from 1 to 16. The parameter FIFOTHR, which the user programs, is one less and ranges from 0 to 15.

A low threshold value (i.e. 2) results in longer periods of time between service requests, but requires faster servicing of the request for both read and write cases. The host reads (writes) from (to) the FIFO until empty (full), then the transfer request goes inactive. The host must be very responsive to the service request. This is the desired case for use with a “fast” system.

A high value of threshold (i.e. 12) is used with a “sluggish” system by affording a long latency period after a service request, but results in more frequent service requests.

Non-DMA Mode – Transfers from the FIFO to the Host

This part does not support non-DMA mode.

Non-DMA Mode – Transfers from the Host to the FIFO

This part does not support non-DMA mode.

DMA Mode – Transfers from the FIFO to the Host

The FDC generates a DMA request cycle when the FIFO contains (16 - <threshold>) bytes, or the last byte of a full sector transfer has been placed in the FIFO. The DMA controller must respond to the request by reading data from the FIFO. The FDC will deactivate the DMA request when the FIFO becomes empty by generating the proper sync for the data transfer.

DMA Mode – Transfers from the Host to the FIFO.

The FDC generates a DMA request cycle when entering the execution phase of the data transfer commands. The DMA controller must respond by placing data in the FIFO. The DMA request remains active until the FIFO becomes full. The DMA request cycle is reasserted when the FIFO has <threshold> bytes remaining in the FIFO. The FDC will terminate the DMA cycle after a TC, indicating that no more data is required.

DATA TRANSFER TERMINATION

The FDC supports terminal count explicitly through the TC pin and implicitly through the underrun/overflow and end-of-track (EOT) functions. For full sector transfers, the EOT parameter can define the last sector to be transferred in a single or multi-sector transfer.

If the last sector to be transferred is a partial sector, the host can stop transferring the data in mid-sector, and the FDC will continue to complete the sector as if a TC cycle was received. The only difference between these implicit functions and TC cycle is that they return “abnormal termination” result status. Such status indications can be ignored if they were expected.

Note that when the host is sending data to the FIFO of the FDC, the internal sector count will be complete when the FDC reads the last byte from its side of the FIFO. There may be a delay in the removal of the transfer request signal of up to the time taken for the FDC to read the last 16 bytes from the FIFO. The host must tolerate this delay.

RESULT PHASE

The generation of the interrupt determines the beginning of the result phase. For each of the commands, a defined set of result bytes has to be read from the FDC before the result phase is complete. These bytes of data must be read out for another command to start.

RQM and DIO must both equal "1" before the result bytes may be read. After all the result bytes have been read, the RQM and DIO bits switch to "1" and "0" respectively, and the CB bit is cleared, indicating that the FDC is ready to accept the next command.

COMMAND SET/DESCRIPTIONS

Commands can be written whenever the FDC is in the command phase. Each command has a unique set of needed parameters and status results. The FDC checks to see that the first byte is a valid command and, if valid, proceeds with the command. If it is invalid, an interrupt is issued. The user sends a Sense Interrupt Status command which returns an invalid command error. Refer to [Table 7.14](#) for explanations of the various symbols used. [Table 7.15](#) lists the required parameters and the results associated with each command that the FDC is capable of performing.

Table 7.14 Description of Command Symbols

SYMBOL	NAME	DESCRIPTION
C	Cylinder Address	The currently selected address; 0 to 255.
D	Data Pattern	The pattern to be written in each sector data field during formatting.
D0, D1	Drive Select 0-1	Designates which drives are perpendicular drives on the Perpendicular Mode Command. A "1" indicates a perpendicular drive.
DIR	Direction Control	If this bit is 0, then the head will step out from the spindle during a relative seek. If set to a 1, the head will step in toward the spindle.
DS0, DS1	Disk Drive Select	00 Drive 0 selected 01 not allowed 1x not allowed
DTL	Special Sector Size	By setting N to zero (00), DTL may be used to control the number of bytes transferred in disk read/write commands. The sector size (N = 0) is set to 128. If the actual sector (on the diskette) is larger than DTL, the remainder of the actual sector is read but is not passed to the host during read commands; during write commands, the remainder of the actual sector is written with all zero bytes. The CRC check code is calculated with the actual sector. When N is not zero, DTL has no meaning and should be set to FF HEX.
EC	Enable Count	When this bit is "1" the "DTL" parameter of the Verify command becomes SC (number of sectors per track).
EFIFO	Enable FIFO	This active low bit when a 0, enables the FIFO. A "1" disables the FIFO (default).
EIS	Enable Implied Seek	When set, a seek operation will be performed before executing any read or write command that requires the C parameter in the command phase. A "0" disables the implied seek.
EOT	End of Track	The final sector number of the current track.
GAP		Alters Gap 2 length when using Perpendicular Mode.
GPL	Gap Length	The Gap 3 size. (Gap 3 is the space between sectors excluding the VCO synchronization field).

Table 7.14 Description of Command Symbols (continued)

SYMBOL	NAME	DESCRIPTION
H/HDS	Head Address	Selected head: 0 or 1 (disk side 0 or 1) as encoded in the sector ID field.
HLT	Head Load Time	The time interval that FDC waits after loading the head and before initializing a read or write operation. Refer to the Specify command for actual delays.
HUT	Head Unload Time	The time interval from the end of the execution phase (of a read or write command) until the head is unloaded. Refer to the Specify command for actual delays.
LOCK		Lock defines whether EFIFO, FIFOTHR, and PRETRK parameters of the CONFIGURE COMMAND can be reset to their default values by a "software Reset". (A reset caused by writing to the appropriate bits of either the DSR or DOR)
MFM	MFM/FM Mode Selector	A one selects the double density (MFM) mode. A zero selects single density (FM) mode.
MT	Multi-Track Selector	When set, this flag selects the multi-track operating mode. In this mode, the FDC treats a complete cylinder under head 0 and 1 as a single track. The FDC operates as this expanded track started at the first sector under head 0 and ended at the last sector under head 1. With this flag set, a multitrack read or write operation will automatically continue to the first sector under head 1 when the FDC finishes operating on the last sector under head 0.
N	Sector Size Code	This specifies the number of bytes in a sector. If this parameter is "00", then the sector size is 128 bytes. The number of bytes transferred is determined by the DTL parameter. Otherwise the sector size is (2 raised to the "N'th" power) times 128. All values up to "07" hex are allowable. "07" would equal a sector size of 16k. It is the user's responsibility to not select combinations that are not possible with the drive. N SECTOR SIZE 00 128 Bytes 01 256 Bytes 02 512 Bytes 03 1024 Bytes ... 07 16K Bytes ...
NCN	New Cylinder Number	The desired cylinder number.
ND	Non-DMA Mode Flag	Write '0'. This part does not support non-DMA mode.
OW	Overwrite	The bits D0-D3 of the Perpendicular Mode Command can only be modified if OW is set to 1. OW is defined in the Lock command.
PCN	Present Cylinder Number	The current position of the head at the completion of Sense Interrupt Status command.
POLL	Polling Disable	When set, the internal polling routine is disabled. When clear, polling is enabled.
PRETRK	Precompensation Start Track Number	Programmable from track 00 to FFh.
R	Sector Address	The sector number to be read or written. In multi-sector transfers, this parameter specifies the sector number of the first sector to be read or written.
RCN	Relative Cylinder Number	Relative cylinder offset from present cylinder as used by the Relative Seek command.
SC	Number of Sectors Per Track	The number of sectors per track to be initialized by the Format command. The number of sectors per track to be verified during a Verify command when EC is set.

Table 7.14 Description of Command Symbols (continued)

SYMBOL	NAME	DESCRIPTION
SK	Skip Flag	When set to 1, sectors containing a deleted data address mark will automatically be skipped during the execution of Read Data. If Read Deleted is executed, only sectors with a deleted address mark will be accessed. When set to "0", the sector is read or written the same as the read and write commands.
SRT	Step Rate Interval	The time interval between step pulses issued by the FDC. Programmable from 0.5 to 8 milliseconds in increments of 0.5 ms at the 1 Mbit data rate. Refer to the SPECIFY command for actual delays.
ST0 ST1 ST2 ST3	Status 0 Status 1 Status 2 Status 3	Registers within the FDC which store status information after a command has been executed. This status information is available to the host during the result phase after command execution.
WGATE	Write Gate	Alters timing of WE to allow for pre-erase loads in perpendicular drives.

Datasheet

7.1.4 Instruction Set**Table 7.15 Instruction Set**

READ DATA										
PHASE	R/W	DATA BUS								REMARKS
		D7	D6	D5	D4	D3	D2	D1	D0	
Command	W	MT	MFM	SK	0	0	1	1	0	Command Codes
	W	0	0	0	0	0	HDS	DS 1	DS 0	
	W	C								Sector ID information prior to Command execution.
	W	H								
	W	R								
	W	N								
	W	EOT								
	W	GPL								
	W	DTL								
Execution										Data transfer between the FDD and system.
Result	R	ST0								Status information after Command execution.
	R	ST1								
	R	ST2								
	R	C								Sector ID information after Command execution.
	R	H								
	R	R								
	R	N								

READ DELETED DATA										
PHASE	R/W	DATA BUS								REMARKS
		D7	D6	D5	D4	D3	D2	D1	D0	
Command	W	MT	MFM	SK	0	1	1	0	0	Command Codes
	W	0	0	0	0	0	HDS	DS1	DS0	

READ DELETED DATA										
PHASE	R/W	DATA BUS								REMARKS
		D7	D6	D5	D4	D3	D2	D1	D0	
	W	C								Sector ID information prior to Command execution.
	W	H								
	W	R								
	W	N								
	W	EOT								
	W	GPL								
	W	DTL								
Execution										Data transfer between the FDD and system.
Result	R	ST0								Status information after Command execution.
	R	ST1								
	R	ST2								
	R	C								Sector ID information after Command execution.
	R	H								
	R	R								
	R	N								

WRITE DATA										
PHASE	R/W	DATA BUS								REMARKS
		D7	D6	D5	D4	D3	D2	D1	D0	
Command	W	MT	MFM	0	0	0	1	0	1	Command Codes
	W	0	0	0	0	0	HDS	DS1	DS0	
	W	C								Sector ID information prior to Command execution.
	W	H								
	W	R								
	W	N								
	W	EOT								

Datasheet

WRITE DATA										
PHASE	R/W	DATA BUS								REMARKS
		D7	D6	D5	D4	D3	D2	D1	D0	
	W	GPL								
	W	DTL								
Execution										Data transfer between the FDD and system.
Result	R	ST0								Status information after Command execution.
	R	ST1								
	R	ST2								
	R	C								Sector ID information after Command execution.
	R	H								
	R	R								
	R	N								

WRITE DELETED DATA										
PHASE	R/W	DATA BUS								REMARKS
		D7	D6	D5	D4	D3	D2	D1	D0	
Command	W	MT	MFM	0	0	1	0	0	1	Command Codes
	W	0	0	0	0	0	HDS	DS1	DS0	
	W	C								Sector ID information prior to Command execution.
	W	H								
	W	R								
	W	N								
	W	EOT								
	W	GPL								
	W	DTL								
Execution										Data transfer between the FDD and system.
Result	R	ST0								Status information after Command execution.
	R	ST1								

WRITE DELETED DATA										
PHASE	R/W	DATA BUS								REMARKS
		D7	D6	D5	D4	D3	D2	D1	D0	
	R	ST2								
	R	C								Sector ID information after Command execution.
	R	H								
	R	R								
	R	N								

READ A TRACK										
PHASE	R/W	DATA BUS								REMARKS
		D7	D6	D5	D4	D3	D2	D1	D0	
Command	W	0	MFM	0	0	0	0	1	0	Command Codes
	W	0	0	0	0	0	HDS	DS1	DS0	
	W	C								Sector ID information prior to Command execution.
	W	H								
	W	R								
	W	N								
	W	EOT								
	W	GPL								
	W	DTL								
Execution										Data transfer between the FDD and system. FDC reads all of cylinders' contents from index hole to EOT.
Result	R	ST0								Status information after Command execution.
	R	ST1								
	R	ST2								
	R	C								Sector ID information after Command execution.
	R	H								
	R	R								

Datasheet

READ A TRACK										
PHASE	R/W	DATA BUS								REMARKS
		D7	D6	D5	D4	D3	D2	D1	D0	
	R	N								

READ A TRACK										
PHASE	R/W	DATA BUS								REMARKS
		D7	D6	D5	D4	D3	D2	D1	D0	
Command	W	MT	MFM	SK	1	0	1	1	0	Command Codes
	W	EC	0	0	0	0	HDS	DS1	DS0	
	W	C								Sector ID information prior to Command execution.
	W	H								
	W	R								
	W	N								
	W	EOT								
	W	GPL								
	W	DTL/SC								
Execution										No data transfer takes place.
Result	R	ST0								Status information after Command execution.
	R	ST1								
	R	ST2								
	R	C								Sector ID information after Command execution.
	R	H								
	R	R								
	R	N								

VERSION										
PHASE	R/W	DATA BUS								REMARKS
		D7	D6	D5	D4	D3	D2	D1	D0	
Command	W	0	0	0	1	0	0	0	0	Command Code
Result	R	1	0	0	1	0	0	0	0	Enhanced Controller

FORMAT A TRACK										
PHASE	R/W	DATA BUS								REMARKS
		D7	D6	D5	D4	D3	D2	D1	D0	
Command	W	0	MFM	0	0	1	1	0	1	Command Codes
	W	0	0	0	0	0	HDS	DS1	DS0	
	W	N								Bytes/Sector
	W	SC								Sectors/Cylinder
	W	GPL								Gap 3
	W	D								Filler Byte
Execution for Each Sector Repeat:	W	C								Input Sector Parameters
	W	H								
	W	R								
	W	N								
										FDC formats an entire cylinder
Result	R	ST0								Status information after Command execution
	R	ST1								
	R	ST2								
	R	Undefined								
	R	Undefined								
	R	Undefined								
	R	Undefined								

Datasheet

RECALIBRATE										
PHASE	R/W	DATA BUS								REMARKS
		D7	D6	D5	D4	D3	D2	D1	D0	
Command	W	0	0	0	0	0	1	1	1	Command Codes
	W	0	0	0	0	0	0	DS1	DS0	
Execution										Head retracted to Track 0 Interrupt.

SENSE INTERRUPT STATUS										
PHASE	R/W	DATA BUS								REMARKS
		D7	D6	D5	D4	D3	D2	D1	D0	
Command	W	0	0	0	0	1	0	0	0	Command Codes
Result	R	ST0								Status information at the end of each seek operation.
	R	PCN								

SPECIFY										
PHASE	R/W	DATA BUS								REMARKS
		D7	D6	D5	D4	D3	D2	D1	D0	
Command	W	0	0	0	0	0	0	1	1	Command Codes
	W	SRT				HUT				
	W	HLT							ND	

SENSE DRIVE STATUS										
PHASE	R/W	DATA BUS								REMARKS
		D7	D6	D5	D4	D3	D2	D1	D0	
Command	W	0	0	0	0	0	1	0	0	Command Codes
	W	0	0	0	0	0	HDS	DS1	DS0	
Result	R	ST3								Status information about FDD

SEEK										
PHASE	R/W	DATA BUS								REMARKS
		D7	D6	D5	D4	D3	D2	D1	D0	
Command	W	0	0	0	0	1	1	1	1	Command Codes
	W	0	0	0	0	0	HDS	DS1	DS0	
	W	NCN								
Execution										Head positioned over proper cylinder on diskette.

CONFIGURE										
PHASE	R/W	DATA BUS								REMARKS
		D7	D6	D5	D4	D3	D2	D1	D0	
Command	W	0	0	0	1	0	0	1	1	Configure Information
	W	0	0	0	0	0	0	0	0	
	W	0	EIS	EFIFO	POLL	FIFOTHR				
Execution	W	PRETRK								

RELATIVE SEEK										
PHASE	R/W	DATA BUS								REMARKS
		D7	D6	D5	D4	D3	D2	D1	D0	
Command	W	1	DIR	0	0	1	1	1	1	
	W	0	0	0	0	0	HDS	DS1	DS0	
	W	RCN								

DUMPREG										
PHASE	R/W	DATA BUS								REMARKS
		D7	D6	D5	D4	D3	D2	D1	D0	
Command	W	0	0	0	0	1	1	1	0	*Note: Registers placed in FIFO

Datasheet

DUMPREG										
PHASE	R/W	DATA BUS								REMARKS
		D7	D6	D5	D4	D3	D2	D1	D0	
Execution										
Result	R	PCN-Drive 0								
	R	PCN-Drive 1								
	R	PCN-Drive 2								
	R	PCN-Drive 3								
	R	SRT				HUT				
	R	HLT							ND	
	R	SC/EOT								
	R	LOCK	0	D3	D2	D1	D0	GAP	WGATE	
	R	0	EIS	EFIFO	POLL	FIFOTHR				
	R	PRETRK								

READ ID										
PHASE	R/W	DATA BUS								REMARKS
		D7	D6	D5	D4	D3	D2	D1	D0	
Command	W	0	MFM	0	0	1	0	1	0	Commands
	W	0	0	0	0	0	HDS	DS1	DS0	
Execution										The first correct ID information on the Cylinder is stored in Data Register
Result	R	ST0								Status information after Command execution. Disk status after the Command has completed.
	R	ST1								
	R	ST2								
	R	C								
	R	H								
	R	R								
	R	N								

PERPENDICULAR MODE										
		DATA BUS								
PHASE	R/W	D7	D6	D5	D4	D3	D2	D1	D0	REMARKS
Command	W	0	0	0	1	0	0	1	0	Command Codes
		OW	0	D3	D2	D1	D0	GAP	WGATE	

INVALID CODES										
		DATA BUS								
PHASE	R/W	D7	D6	D5	D4	D3	D2	D1	D0	REMARKS
Command	W	Invalid Codes								Invalid Command Codes (NoOp – FDC goes into Standby State)
Result	R	ST0								ST0 = 80H

LOCK										
		DATA BUS								
PHASE	R/W	D7	D6	D5	D4	D3	D2	D1	D0	REMARKS
Command	W	LOCK	0	0	1	0	1	0	0	Command Codes
Result	R	0	0	0	LOCK	0	0	0	0	

SC is returned if the last command that was issued was the Format command. EOT is returned if the last command was a Read or Write.

Note: These bits are used internally only. They are not reflected in the Drive Select pins. It is the user's responsibility to maintain correspondence between these bits and the Drive Select pins (DOR).

7.1.5 Data Transfer Commands

All of the Read Data, Write Data and Verify type commands use the same parameter bytes and return the same results information, the only difference being the coding of bits 0-4 in the first byte.

An implied seek will be executed if the feature was enabled by the Configure command. This seek is completely transparent to the user. The Drive Busy bit for the drive will go active in the Main Status Register during the seek portion of the command. If the seek portion fails, it is reflected in the results status normally returned for a Read/Write Data command. Status Register 0 (ST0) would contain the error code and C would contain the cylinder on which the seek failed.

Datasheet**READ DATA**

A set of nine (9) bytes is required to place the FDC in the Read Data Mode. After the Read Data command has been issued, the FDC loads the head (if it is in the unloaded state), waits the specified head settling time (defined in the Specify command), and begins reading ID Address Marks and ID fields. When the sector address read off the diskette matches with the sector address specified in the command, the FDC reads the sector's data field and transfers the data to the FIFO.

After completion of the read operation from the current sector, the sector address is incremented by one and the data from the next logical sector is read and output via the FIFO. This continuous read function is called "Multi-Sector Read Operation". Upon receipt of the TC cycle, or an implied TC (FIFO overrun/underrun), the FDC stops sending data but will continue to read data from the current sector, check the CRC bytes, and at the end of the sector, terminate the Read Data Command.

N determines the number of bytes per sector (see [Table 7.16](#)). If N is set to zero, the sector size is set to 128. The DTL value determines the number of bytes to be transferred. If DTL is less than 128, the FDC transfers the specified number of bytes to the host. For reads, it continues to read the entire 128-byte sector and checks for CRC errors. For writes, it completes the 128-byte sector by filling in zeros. If N is not set to 00 Hex, DTL should be set to FF Hex and has no impact on the number of bytes transferred.

Table 7.16 Sector Sizes

N	SECTOR SIZE
00	128 bytes
01	256 bytes
02	512 bytes
03	1024 bytes
..	...
07	16 Kbytes

The amount of data which can be handled with a single command to the FDC depends upon MT (multi-track) and N (number of bytes/sector).

The Multi-Track function (MT) allows the FDC to read data from both sides of the diskette. For a particular cylinder, data will be transferred starting at Sector 1, Side 0 and completing the last sector of the same track at Side 1.

If the host terminates a read or write operation in the FDC, the ID information in the result phase is dependent upon the state of the MT bit and EOT byte. Refer to [Table 7.17](#).

At the completion of the Read Data command, the head is not unloaded until after the Head Unload Time Interval (specified in the Specify command) has elapsed. If the host issues another command before the head unloads, then the head settling time may be saved between subsequent reads.

If the FDC detects a pulse on the nINDEX pin twice without finding the specified sector (meaning that the diskette's index hole passes through index detect logic in the drive twice), the FDC sets the IC code in Status Register 0 to "01" indicating abnormal termination, sets the ND bit in Status Register 1 to "1" indicating a sector not found, and terminates the Read Data Command.

After reading the ID and Data Fields in each sector, the FDC checks the CRC bytes. If a CRC error occurs in the ID or data field, the FDC sets the IC code in Status Register 0 to "01" indicating abnormal termination, sets the DE bit flag in Status Register 1 to "1", sets the DD bit in Status Register 2 to "1" if CRC is incorrect in the ID field, and terminates the Read Data Command. [Table 7.18](#) describes the effect of the SK bit on the Read Data command execution and results. Except where noted in [Table 7.18](#), the C or R value of the sector address is automatically incremented (see [Table 7.20 on page 67](#)).

Table 7.17 Effects of MT and N Bits

MT	N	MAXIMUM TRANSFER CAPACITY	FINAL SECTOR READ FROM DISK
0	1	256 x 26 = 6,656	26 at side 0 or 1
1	1	256 x 52 = 13,312	26 at side 1
0	2	512 x 15 = 7,680	15 at side 0 or 1
1	2	512 x 30 = 15,360	15 at side 1
0	3	1024 x 8 = 8,192	8 at side 0 or 1
1	3	1024 x 16 = 16,384	16 at side 1

Table 7.18 Skip Bit vs. Read Data Command

SK BIT VALUE	DATA ADDRESS MARK TYPE ENCOUNTERED	RESULTS		
		SECTOR READ?	CM BIT OF ST2 SET?	DESCRIPTION OF RESULTS
0	Normal Data	Yes	No	Normal termination. Address not incremented. Next sector not searched for. Normal termination. Sector not read ("skipped").
0	Deleted Data	Yes	Yes	
1	Normal Data	Yes	No	
1	Deleted Data	No	Yes	

READ DELETED DATA

This command is the same as the Read Data command, only it operates on sectors that contain a Deleted Data Address Mark at the beginning of a Data Field.

[Table 7.19](#) describes the effect of the SK bit on the Read Deleted Data command execution and results. Except where noted in [Table 7.19](#), the C or R value of the sector address is automatically incremented (see [Table 7.20](#)).

Table 7.19 Skip Bit vs. Read Deleted Data Command

SK BIT VALUE	DATA ADDRESS MARK TYPE ENCOUNTERED	RESULTS		
		SECTOR READ?	CM BIT OF ST2 SET?	DESCRIPTION OF RESULTS
0	Normal Data	Yes	Yes	Address not incremented. Next sector not searched for. Normal termination. Sector not read ("skipped"). Normal termination.
0	Deleted Data	Yes	No	
1	Normal Data	No	Yes	
1	Deleted Data	Yes	No	

Datasheet**READ A TRACK**

This command is similar to the Read Data command except that the entire data field is read continuously from each of the sectors of a track. Immediately after encountering a pulse on the nINDEX pin, the FDC starts to read all data fields on the track as continuous blocks of data without regard to logical sector numbers. If the FDC finds an error in the ID or DATA CRC check bytes, it continues to read data from the track and sets the appropriate error bits at the end of the command. The FDC compares the ID information read from each sector with the specified value in the command and sets the ND flag of Status Register 1 to a "1" if there no comparison. Multi-track or skip operations are not allowed with this command. The MT and SK bits (bits D7 and D5 of the first command byte respectively) should always be set to "0".

This command terminates when the EOT specified number of sectors has not been read. If the FDC does not find an ID Address Mark on the diskette after the second occurrence of a pulse on the nINDEX pin, then it sets the IC code in Status Register 0 to "01" (abnormal termination), sets the MA bit in Status Register 1 to "1", and terminates the command.

Table 7.20 Result Phase

MT	HEAD	FINAL SECTOR TRANSFERRED TO	ID INFORMATION AT RESULT PHASE			
			C	H	R	N
		HOST	C	H	R	N
0	0	Less than EOT	NC	NC	R + 1	NC
		Equal to EOT	C + 1	NC	01	NC
	1	Less than EOT	NC	NC	R + 1	NC
		Equal to EOT	C + 1	NC	01	NC
1	0	Less than EOT	NC	NC	R + 1	NC
		Equal to EOT	NC	LSB	01	NC
	1	Less than EOT	NC	NC	R + 1	NC
		Equal to EOT	C + 1	LSB	01	NC

NC: No Change, the same value as the one at the beginning of command execution.

LSB: Least Significant Bit, the LSB of H is complemented.

WRITE DATA

After the Write Data command has been issued, the FDC loads the head (if it is in the unloaded state), waits the specified head load time if unloaded (defined in the Specify command), and begins reading ID fields. When the sector address read from the diskette matches the sector address specified in the command, the FDC reads the data from the host via the FIFO and writes it to the sector's data field.

After writing data into the current sector, the FDC computes the CRC value and writes it into the CRC field at the end of the sector transfer. The Sector Number stored in "R" is incremented by one, and the FDC continues writing to the next data field. The FDC continues this "Multi-Sector Write Operation". Upon receipt of a terminal count signal or if a FIFO over/under run occurs while a data field is being written, then the remainder of the data field is filled with zeros. The FDC reads the ID field of each sector and checks the CRC bytes. If it detects a CRC error in one of the ID fields, it sets the IC code in Status Register 0 to "01" (abnormal termination), sets the DE bit of Status Register 1 to "1", and terminates the Write Data command.

The Write Data command operates in much the same manner as the Read Data command. The following items are the same. Please refer to the Read Data Command for details:

Transfer Capacity

EN (End of Cylinder) bit

ND (No Data) bit

Head Load, Unload Time Interval

ID information when the host terminates the command

Definition of DTL when N = 0 and when N does not = 0

WRITE DELETED DATA

This command is almost the same as the Write Data command except that a Deleted Data Address Mark is written at the beginning of the Data Field instead of the normal Data Address Mark. This command is typically used to mark a bad sector containing an error on the floppy disk.

Verify

The Verify command is used to verify the data stored on a disk. This command acts exactly like a Read Data command except that no data is transferred to the host. Data is read from the disk and CRC is computed and checked against the previously-stored value.

Because data is not transferred to the host, the TC cycle cannot be used to terminate this command. By setting the EC bit to "1", an implicit TC will be issued to the FDC. This implicit TC will occur when the SC value has decremented to 0 (an SC value of 0 will verify 256 sectors). This command can also be terminated by setting the EC bit to "0" and the EOT value equal to the final sector to be checked. If EC is set to "0", DTL/SC should be programmed to 0FFH. Refer to [Table 7.20 on page 67](#) and [Table 7.21 on page 68](#) for information concerning the values of MT and EC versus SC and EOT value.

Definitions:

Sectors Per Side = Number of formatted sectors per each side of the disk.

Sectors Remaining = Number of formatted sectors left which can be read, including side 1 of the disk if MT is set to "1".

Table 7.21 Verify Command Result Phase

MT	EC	SC/EOT VALUE	TERMINATION RESULT
0	0	SC = DTL EOT <= # Sectors Per Side	Success Termination Result Phase Valid
0	0	SC = DTL EOT > # Sectors Per Side	Unsuccessful Termination Result Phase Invalid
0	1	SC <= # Sectors Remaining AND EOT <= # Sectors Per Side	Successful Termination Result Phase Valid
0	1	SC > # Sectors Remaining OR EOT > # Sectors Per Side	Unsuccessful Termination Result Phase Invalid
1	0	SC = DTL EOT <= # Sectors Per Side	Successful Termination Result Phase Valid
1	0	SC = DTL EOT > # Sectors Per Side	Unsuccessful Termination Result Phase Invalid
1	1	SC <= # Sectors Remaining AND EOT <= # Sectors Per Side	Successful Termination Result Phase Valid
1	1	SC > # Sectors Remaining OR EOT > # Sectors Per Side	Unsuccessful Termination Result Phase Invalid

Datasheet

Note: If MT is set to “1” and the SC value is greater than the number of remaining formatted sectors on Side 0, verifying will continue on Side 1 of the disk.

FORMAT A TRACK

The Format command allows an entire track to be formatted. After a pulse from the nINDEX pin is detected, the FDC starts writing data on the disk including gaps, address marks, ID fields, and data fields per the IBM System 34 or 3740 format (MFM or FM respectively). The particular values that will be written to the gap and data field are controlled by the values programmed into N, SC, GPL, and D which are specified by the host during the command phase. The data field of the sector is filled with the data byte specified by D. The ID field for each sector is supplied by the host; that is, four data bytes per sector are needed by the FDC for C, H, R, and N (cylinder, head, sector number and sector size respectively).

After formatting each sector, the host must send new values for C, H, R and N to the FDC for the next sector on the track. The R value (sector number) is the only value that must be changed by the host after each sector is formatted. This allows the disk to be formatted with nonsequential sector addresses (interleaving). This incrementing and formatting continues for the whole track until the FDC encounters a pulse on the nINDEX pin again and it terminates the command.

[Table 7.22 on page 70](#) contains typical values for gap fields which are dependent upon the size of the sector and the number of sectors on each track. Actual values can vary due to drive electronics.

FORMAT FIELDS																		
SYSTEM 34 (DOUBLE DENSITY) FORMAT																		
GAP 4a 80x 4E	SYN C 12x 00	IAM		GA P1 50x 4E	SYN C 12x 00	IDA M	C Y L	H D	S E C	N O	C R C	GA P2 22x 4E	SYN C 12x 00	DAT A AM	DA TA	C R C	GA P3	GAP 4b
		3 x C 2	F C			3 x A 1								3 x A 1	F B F 8			
SYSTEM 3740 (SINGLE DENSITY) FORMAT																		
GAP 4a 40x FF	SYN C 6x 00	IAM		GA P1 26x FF	SYN C 6x 00	IDA M	C Y L	H D	S E C	N O	C R C	GA P2 11x FF	SYN C 6x 00	DAT A AM	DA TA	C R C	GA P3	GAP 4b
		FC				FE								FB or F8				
PERPENDICULAR FORMAT																		
GAP 4a 80x 4E	SYN C 12x 00	IAM		GA P1 50x 4E	SYN C 12x 00	IDA M	C Y L	H D	S E C	N O	C R C	GA P2 41x 4E	SYN C 12x 00	DAT A AM	DA TA	C R C	GA P3	GAP 4b
		3 x C 2	F C			3 x A 1								3 x A 1	F B F 8			

Table 7.22 Typical Values for Formatting

	FORMAT	SECTOR SIZE	N	SC	GPL1	GPL2
5.25" Drives	FM	128	00	12	07	09
		128	00	10	10	19
		512	02	08	18	30
		1024	03	04	46	87
		2048	04	02	C8	FF
		4096	05	01	C8	FF
				
	MFM	256	01	12	0A	0C
		256	01	10	20	32
		512*	02	09	2A	50
		1024	03	04	80	F0
		2048	04	02	C8	FF
		4096	05	01	C8	FF
				
3.5" Drives	FM	128	0	0F	07	1B
		256	1	09	0F	2A
		512	2	05	1B	3A
3.5" Drives	MFM	256	1	0F	0E	36
		512**	2	09	1B	54
		1024	3	05	35	74
GPL1 = suggested GPL values in Read and Write commands to avoid splice point between data field and ID field of contiguous sections. GPL2 = suggested GPL value in Format A Track command. *PC/AT values (typical) **PS/2 values (typical). Applies with 1.0 MB and 2.0 MB drives. Note: All values except sector size are in hex.						

CONTROL COMMANDS

Control commands differ from the other commands in that no data transfer takes place. Three commands generate an interrupt when complete: Read ID, Re calibrate, and Seek. The other control commands do not generate an interrupt.

Read ID

The Read ID command is used to find the present position of the recording heads. The FDC stores the values from the first ID field it is able to read into its registers. If the FDC does not find an ID address mark on the diskette after the second occurrence of a pulse on the nINDEX pin, it then sets the IC code in Status Register 0 to "01" (abnormal termination), sets the MA bit in Status Register 1 to "1", and terminates the command.

The following commands will generate an interrupt upon completion. They do not return any result bytes. It is highly recommended that control commands be followed by the Sense Interrupt Status command. Otherwise, valuable interrupt status information will be lost.

Recalibrate

This command causes the read/write head within the FDC to retract to the track 0 position. The FDC clears the contents of the PCN counter and checks the status of the nTRK0 pin from the FDD. As long as the nTRK0 pin is low, the DIR pin remains 0 and step pulses are issued. When the nTRK0 pin goes high, the SE bit in Status Register 0 is set to "1" and the command is terminated. If the nTRK0 pin is still low after 79 step pulses have been issued, the FDC sets the SE and the EC bits of Status Register 0 to "1" and terminates the command. Disks capable of handling more than 80 tracks per side may require more than one Recalibrate command to return the head back to physical Track 0.

Datasheet

The Recalibrate command does not have a result phase. The Sense Interrupt Status command must be issued after the Recalibrate command to effectively terminate it and to provide verification of the head position (PCN). During the command phase of the recalibrate operation, the FDC is in the BUSY state, but during the execution phase it is in a NON-BUSY state. At this time, another Recalibrate command may be issued, and in this manner parallel Recalibrate operations may be done on up to four drives at once. Upon power up, the software must issue a Recalibrate command to properly initialize all drives and the controller.

Seek

The read/write head within the drive is moved from track to track under the control of the Seek command. The FDC compares the PCN, which is the current head position, with the NCN and performs the following operation if there is a difference:

- PCN < NCN: Direction signal to drive set to "1" (step in) and issues step pulses.
- PCN > NCN: Direction signal to drive set to "0" (step out) and issues step pulses.

The rate at which step pulses are issued is controlled by SRT (Stepping Rate Time) in the Specify command. After each step pulse is issued, NCN is compared against PCN, and when NCN = PCN the SE bit in Status Register 0 is set to "1" and the command is terminated. During the command phase of the seek or recalibrate operation, the FDC is in the BUSY state, but during the execution phase it is in the NON-BUSY state. At this time, another Seek or Recalibrate command may be issued, and in this manner, parallel seek operations may be done on up to four drives at once.

Note that if implied seek is not enabled, the read and write commands should be preceded by:

1. Seek command - Step to the proper track
2. Sense Interrupt Status command - Terminate the Seek command
3. Read ID - Verify head is on proper track
4. Issue Read/Write command.

The Seek command does not have a result phase. Therefore, it is highly recommended that the Sense Interrupt Status command is issued after the Seek command to terminate it and to provide verification of the head position (PCN). The H bit (Head Address) in ST0 will always return to a "0". When exiting POWERDOWN mode, the FDC clears the PCN value and the status information to zero. Prior to issuing the POWERDOWN command, it is highly recommended that the user service all pending interrupts through the Sense Interrupt Status command.

SENSE INTERRUPT STATUS

An interrupt signal is generated by the FDC for one of the following reasons:

1. Upon entering the Result Phase of:
 - a. Read Data command
 - b. Read A Track command
 - c. Read ID command
 - d. Read Deleted Data command
 - e. Write Data command
 - f. Format A Track command
 - g. Write Deleted Data command
 - h. Verify command
2. End of Seek, Relative Seek, or Recalibrate command

The Sense Interrupt Status command resets the interrupt signal and, via the IC code and SE bit of Status Register 0, identifies the cause of the interrupt.

Table 7.23 Interrupt Identification

SE	IC	INTERRUPT DUE TO
0	11	Polling
1	00	Normal termination of Seek or Recalibrate command
		Abnormal termination of Seek or Recalibrate command
1	01	

The Seek, Relative Seek, and Recalibrate commands have no result phase. The Sense Interrupt Status command must be issued immediately after these commands to terminate them and to provide verification of the head position (PCN). The H (Head Address) bit in ST0 will always return a "0". If a Sense Interrupt Status is not issued, the drive will continue to be BUSY and may affect the operation of the next command.

SENSE DRIVE STATUS

Sense Drive Status obtains drive status information. It has no execution phase and goes directly to the result phase from the command phase. Status Register 3 contains the drive status information.

Specify

The Specify command sets the initial values for each of the three internal times. The HUT (Head Unload Time) defines the time from the end of the execution phase of one of the read/write commands to the head unload state. The SRT (Step Rate Time) defines the time interval between adjacent step pulses. Note that the spacing between the first and second step pulses may be shorter than the remaining step pulses. The HLT (Head Load Time) defines the time between when the Head Load signal goes high and the read/write operation starts. The values change with the data rate speed selection and are documented in [Table 7.24](#). The values are the same for MFM and FM.

DMA operation is selected by the ND bit. When ND is "0", the DMA mode is selected. This part does not support non-DMA mode. In DMA mode, data transfers are signaled by the DMA request cycles.

Configure

The Configure command is issued to select the special features of the FDC. A Configure command need not be issued if the default values of the FDC meet the system requirements.

Table 7.24 Drive Control Delays (ms)

	HUT					SRT				
	2M	1M	500K	300K	250K	2M	1M	500K	300K	250K
0	64	128	256	426	512	4	8	16	26.7	32
1	4	8	16	26.7	32	3.75	7.5	15	25	30
.
E	56	112	224	373	448	0.5	1	2	3.33	4
F	60	120	240	400	480	0.25	0.5	1	1.67	2

Datasheet

	HLT				
	2M	1M	500K	300K	250K
00	64	128	256	426	512
01	0.5	1	2	3.3	4
02	1	2	4	6.7	8
..
7F	63	126	252	420	504
7F	63.5	127	254	423	508

Configure Default Values:

EIS - No Implied Seeks

EFIFO - FIFO Disabled

POLL - Polling Enabled

FIFOTHR - FIFO Threshold Set to 1 Byte

PRETRK - Pre-Compensation Set to Track 0

EIS - Enable Implied Seek. When set to "1", the FDC will perform a Seek operation before executing a read or write command. Defaults to no implied seek.

EFIFO - A "1" disables the FIFO (default). This means data transfers are asked for on a byte-by-byte basis. Defaults to "1", FIFO disabled. The threshold defaults to "1".

POLL - Disable polling of the drives. Defaults to "0", polling enabled. When enabled, a single interrupt is generated after a reset. No polling is performed while the drive head is loaded and the head unload delay has not expired.

FIFOTHR - The FIFO threshold in the execution phase of read or write commands. This is programmable from 1 to 16 bytes. Defaults to one byte. A "00" selects one byte; "0F" selects 16 bytes.

PRETRK - Pre-Compensation Start Track Number. Programmable from track 0 to 255. Defaults to track 0. A "00" selects track 0; "FF" selects track 255.

Version

The Version command checks to see if the controller is an enhanced type or the older type (765A). A value of 90 H is returned as the result byte.

Relative Seek

The command is coded the same as for Seek, except for the MSB of the first byte and the DIR bit.

DIR Head Step Direction Control

RCN Relative Cylinder Number that determines how many tracks to step the head in or out from the current track number.

DIR	ACTION
0	Step Head Out
1	Step Head In

The Relative Seek command differs from the Seek command in that it steps the head the absolute number of tracks specified in the command instead of making a comparison against an internal

register. The Seek command is good for drives that support a maximum of 256 tracks. Relative Seeks cannot be overlapped with other Relative Seeks. Only one Relative Seek can be active at a time. Relative Seeks may be overlapped with Seeks and Recalibrates. Bit 4 of Status Register 0 (EC) will be set if Relative Seek attempts to step outward beyond Track 0.

As an example, assume that a floppy drive has 300 usable tracks. The host needs to read track 300 and the head is on any track (0-255). If a Seek command is issued, the head will stop at track 255. If a Relative Seek command is issued, the FDC will move the head the specified number of tracks, regardless of the internal cylinder position register (but will increment the register). If the head was on track 40 (D), the maximum track that the FDC could position the head on using Relative Seek will be 295 (D), the initial track + 255 (D). The maximum count that the head can be moved with a single Relative Seek command is 255 (D).

The internal register, PCN, will overflow as the cylinder number crosses track 255 and will contain 39 (D). The resulting PCN value is thus $(RCN + PCN) \bmod 256$. Functionally, the FDC starts counting from 0 again as the track number goes above 255 (D). It is the user's responsibility to compensate FDC functions (precompensation track number) when accessing tracks greater than 255. The FDC does not keep track that it is working in an "extended track area" (greater than 255). Any command issued will use the current PCN value except for the Recalibrate command, which only looks for the TRACK0 signal. Recalibrate will return an error if the head is farther than 79 due to its limitation of issuing a maximum of 80 step pulses. The user simply needs to issue a second Recalibrate command. The Seek command and implied seeks will function correctly within the 44 (D) track (299-255) area of the "extended track area". It is the user's responsibility not to issue a new track position that will exceed the maximum track that is present in the extended area.

To return to the standard floppy range (0-255) of tracks, a Relative Seek should be issued to cross the track 255 boundary.

A Relative Seek can be used instead of the normal Seek, but the host is required to calculate the difference between the current head location and the new (target) head location. This may require the host to issue a Read ID command to ensure that the head is physically on the track that software assumes it to be. Different FDC commands will return different cylinder results which may be difficult to keep track of with software without the Read ID command.

PERPENDICULAR MODE

The Perpendicular Mode command should be issued prior to executing Read/Write/Format commands that access a disk drive with perpendicular recording capability. With this command, the length of the Gap2 field and VCO enable timing can be altered to accommodate the unique requirements of these drives. [Table 7.25 on page 75](#) describes the effects of the WGATE and GAP bits for the Perpendicular Mode command. Upon a reset, the FDC will default to the conventional mode (WGATE = 0, GAP = 0).

Selection of the 500 Kbps and 1 Mbps perpendicular modes is independent of the actual data rate selected in the Data Rate Select Register. The user must ensure that these two data rates remain consistent.

The Gap2 and VCO timing requirements for perpendicular recording type drives are dictated by the design of the read/write head. In the design of this head, a pre-erase head precedes the normal read/write head by a distance of 200 micrometers. This works out to about 38 bytes at a 1 Mbps recording density. Whenever the write head is enabled by the Write Gate signal, the pre-erase head is also activated at the same time. Thus, when the write head is initially turned on, flux transitions recorded on the media for the first 38 bytes will not be preconditioned with the pre-erase head since it has not yet been activated. To accommodate this head activation and deactivation time, the Gap2 field is expanded to a length of 41 bytes. The Format Fields table illustrates the change in the Gap2 field size for the perpendicular format.

On the read back by the FDC, the controller must begin synchronization at the beginning of the sync field. For the conventional mode, the internal PLL VCO is enabled (VCOEN) approximately 24 bytes from the start of the Gap2 field. But, when the controller operates in the 1 Mbps perpendicular mode (WGATE = 1, GAP = 1), VCOEN goes active after 43 bytes to accommodate the increased Gap2 field size. For both cases, an approximate two-byte cushion is maintained from the beginning of the sync field for the purposes of avoiding write splices in the presence of motor speed variation.

Datasheet

For the Write Data case, the FDC activates Write Gate at the beginning of the sync field under the conventional mode. The controller then writes a new sync field, data address mark, data field, and CRC. With the pre-erase head of the perpendicular drive, the write head must be activated in the Gap2 field to insure a proper write of the new sync field. For the 1 Mbps perpendicular mode (WGATE = 1, GAP = 1), 38 bytes will be written in the Gap2 space. Since the bit density is proportional to the data rate, 19 bytes will be written in the Gap2 field for the 500 Kbps perpendicular mode (WGATE = 1, GAP = 0).

It should be noted that none of the alterations in Gap2 size, VCO timing, or Write Gate timing affect normal program flow. The information provided here is just for background purposes and is not needed for normal operation. Once the Perpendicular Mode command is invoked, FDC software behavior from the user standpoint is unchanged.

The perpendicular mode command is enhanced to allow specific drives to be designated Perpendicular recording drives. This enhancement allows data transfers between Conventional and Perpendicular drives without having to issue Perpendicular mode commands between the accesses of the different drive types, nor having to change write pre-compensation values.

When both GAP and WGATE bits of the PERPENDICULAR MODE COMMAND are both programmed to “0” (Conventional mode), then D0, D1, D2, D3, and D4 can be programmed independently to “1” for that drive to be set automatically to Perpendicular mode. In this mode the following set of conditions also apply:

- The GAP2 written to a perpendicular drive during a write operation will depend upon the programmed data rate.
- The write pre-compensation given to a perpendicular mode drive will be 0ns.
- For D0-D3 programmed to “0” for conventional mode drives any data written will be at the currently programmed write pre-compensation.

Note: Bits D0-D3 can only be overwritten when OW is programmed as a “1”. If either GAP or WGATE is a “1” then D0-D3 are ignored.

Software and hardware resets have the following effect on the PERPENDICULAR MODE COMMAND:

1. “Software” resets (via the DOR or DSR registers) will only clear GAP and WGATE bits to “0”. D0-D3 are unaffected and retain their previous value.
2. “Hardware” resets will clear all bits (GAP, WGATE and D0-D3) to “0”, i.e all conventional mode.

Table 7.25 Effects of WGATE and GAP Bits

WGATE	GAP	MODE	LENGTH OF GAP2 FORMAT FIELD	PORTION OF GAP 2 WRITTEN BY WRITE DATA OPERATION
0	0	Conventional	22 Bytes	0 Bytes
0	1	Perpendicular (500 Kbps)	22 Bytes	19 Bytes
1	0	Reserved (Conventional)	22 Bytes	0 Bytes
1	1	Perpendicular (1 Mbps)	41 Bytes	38 Bytes

Lock

In order to protect systems with long DMA latencies against older application software that can disable the FIFO the LOCK Command has been added. This command should only be used by the FDC routines, and application software should refrain from using it. If an application calls for the FIFO to be disabled then the CONFIGURE command should be used.

The LOCK command defines whether the EFIFO, FIFOTHR, and PRETRK parameters of the CONFIGURE command can be RESET by the DOR and DSR registers. When the LOCK bit is set to

logic “1” all subsequent “software RESETS by the DOR and DSR registers will not change the previously set parameters to their default values. All “hardware” RESET from the PCI_RESET# pin will set the LOCK bit to logic “0” and return the EFIFO, FIFOTHR, and PRETRK to their default values. A status byte is returned immediately after issuing a LOCK command. This byte reflects the value of the LOCK bit set by the command byte.

Enhanced Dumpreg

The DUMPREG command is designed to support system run-time diagnostics and application software development and debug. To accommodate the LOCK command and the enhanced PERPENDICULAR MODE command the eighth byte of the DUMPREG command has been modified to contain the additional data from these two commands.

COMPATIBILITY

The SCH311X was designed with software compatibility in mind. It is a fully backwards-compatible solution with the older generation 765A/B disk controllers. The FDC also implements on-board registers for compatibility with the PS/2, as well as PC/AT and PC/XT, floppy disk controller subsystems. After a hardware reset of the FDC, all registers, functions and enhancements default to a PC/AT, PS/2 or PS/2 Model 30 compatible operating mode, depending on how the IDENT and MFM bits are configured by the system BIOS.

Chapter 8 Serial Port (UART)

The SCH3112 incorporates two full function UARTs. The SCH3114 incorporates four full function UARTs. The SCH3116 incorporates four full function UARTs, and two, 4 pin UARTs. They are compatible with the NS16450, the 16450 ACE registers and the NS16C550A. The UARTS perform serial-to-parallel conversion on received characters and parallel-to-serial conversion on transmit characters. The data rates are independently programmable from 460.8K baud down to 50 baud. The character options are programmable for 1 start; 1, 1.5 or 2 stop bits; even, odd, sticky or no parity; and prioritized interrupts. The UARTs each contain a programmable baud rate generator that is capable of dividing the input clock or crystal by a number from 1 to 65535. The UARTs are also capable of supporting the MIDI data rate. Refer to the Configuration Registers for information on disabling, power down and changing the base address of the UARTs. The interrupt from a UART is enabled by programming OUT2 of that UART to a logic "1". OUT2 being a logic "0" disables that UART's interrupt. The second UART also supports IrDA, HP-SIR and ASK-IR modes of operation.

Register Description

Addressing of the accessible registers of the Serial Port is shown below. The base addresses of the serial ports are defined by the configuration registers (see [Chapter 25, "Config Registers," on page 269](#)). The Serial Port registers are located at sequentially increasing addresses above these base addresses. The register set of the UARTS are described below.

Table 8.1 Addressing the Serial Port

DLAB*	A2	A1	A0	REGISTER NAME
0	0	0	0	Receive Buffer (read)
0	0	0	0	Transmit Buffer (write)
0	0	0	1	Interrupt Enable (read/write)
X	0	1	0	Interrupt Identification (read)
X	0	1	0	FIFO Control (write)
X	0	1	1	Line Control (read/write)
X	1	0	0	Modem Control (read/write)
X	1	0	1	Line Status (read/write)
X	1	1	0	Modem Status (read/write)
X	1	1	1	Scratchpad (read/write)
1	0	0	0	Divisor LSB (read/write)
1	0	0	1	Divisor MSB (read/write)

Note: *DLAB is Bit 7 of the Line Control Register

The following section describes the operation of the registers.

RECEIVE BUFFER REGISTER (RB)

Address Offset = 0H, DLAB = 0, READ ONLY

This register holds the received incoming data byte. Bit 0 is the least significant bit, which is transmitted and received first. Received data is double buffered; this uses an additional shift register

to receive the serial data stream and convert it to a parallel 8 bit word which is transferred to the Receive Buffer register. The shift register is not accessible.

TRANSMIT BUFFER REGISTER (TB)

Address Offset = 0H, DLAB = 0, WRITE ONLY

This register contains the data byte to be transmitted. The transmit buffer is double buffered, utilizing an additional shift register (not accessible) to convert the 8 bit data word to a serial format. This shift register is loaded from the Transmit Buffer when the transmission of the previous byte is complete.

INTERRUPT ENABLE REGISTER (IER)

Address Offset = 1H, DLAB = 0, READ/WRITE

The lower four bits of this register control the enables of the five interrupt sources of the Serial Port interrupt. It is possible to totally disable the interrupt system by resetting bits 0 through 3 of this register. Similarly, setting the appropriate bits of this register to a high, selected interrupts can be enabled. Disabling the interrupt system inhibits the Interrupt Identification Register and disables any Serial Port interrupt out of the SCH311X. All other system functions operate in their normal manner, including the Line Status and MODEM Status Registers. The contents of the Interrupt Enable Register are described below.

Bit 0

This bit enables the Received Data Available Interrupt (and timeout interrupts in the FIFO mode) when set to logic "1".

Bit 1

This bit enables the Transmitter Holding Register Empty Interrupt when set to logic "1".

Bit 2

This bit enables the Received Line Status Interrupt when set to logic "1". The error sources causing the interrupt are Overrun, Parity, Framing and Break. The Line Status Register must be read to determine the source.

Bit 3

This bit enables the MODEM Status Interrupt when set to logic "1". This is caused when one of the Modem Status Register bits changes state.

Bits 4 through 7

These bits are always logic "0".

FIFO CONTROL REGISTER (FCR)

Address Offset = 2H, DLAB = X, WRITE

This is a write only register at the same location as the IIR. This register is used to enable and clear the FIFOs, set the RCVR FIFO trigger level. Note: DMA is not supported. The UART1 and UART2 FCRs are shadowed in the UART1 FIFO Control Shadow Register (runtime register at offset 0x20) and UART2 FIFO Control Shadow Register (runtime register at offset 0x21).

Bit 0

Setting this bit to a logic "1" enables both the XMIT and RCVR FIFOs. Clearing this bit to a logic "0" disables both the XMIT and RCVR FIFOs and clears all bytes from both FIFOs. When changing from FIFO Mode to non-FIFO (16450) mode, data is automatically cleared from the FIFOs. This bit must be a 1 when other bits in this register are written to or they will not be properly programmed.

Datasheet**Bit 1**

Setting this bit to a logic “1” clears all bytes in the RCVR FIFO and resets its counter logic to 0. The shift register is not cleared. This bit is self-clearing.

Bit 2

Setting this bit to a logic “1” clears all bytes in the XMIT FIFO and resets its counter logic to 0. The shift register is not cleared. This bit is self-clearing.

Bit 3

Writing to this bit has no effect on the operation of the UART. The RXRDY and TXRDY pins are not available on this chip.

Bit 4,5

Reserved

Bit 6,7

These bits are used to set the Trigger Level For The Rcvr Fifo Interrupt.

INTERRUPT IDENTIFICATION REGISTER (IIR)

Address Offset = 2H, DLAB = X, READ

By accessing this register, the host CPU can determine the highest priority interrupt and its source. Four levels of priority interrupt exist. They are in descending order of priority:

1. Receiver Line Status (highest priority)
2. Received Data Ready
3. Transmitter Holding Register Empty
4. MODEM Status (lowest priority)

Information indicating that a prioritized interrupt is pending and the source of that interrupt is stored in the Interrupt Identification Register (refer to [Table 8.2 on page 80](#)). When the CPU accesses the IIR, the Serial Port freezes all interrupts and indicates the highest priority pending interrupt to the CPU. During this CPU access, even if the Serial Port records new interrupts, the current indication does not change until access is completed. The contents of the IIR are described below.

Bit 0

This bit can be used in either a hardwired prioritized or polled environment to indicate whether an interrupt is pending. When bit 0 is a logic “0”, an interrupt is pending and the contents of the IIR may be used as a pointer to the appropriate internal service routine. When bit 0 is a logic “1”, no interrupt is pending.

Bits 1 and 2

These two bits of the IIR are used to identify the highest priority interrupt pending as indicated by the Interrupt Control Table ([Table 8.2](#)).

Bit 3

In non-FIFO mode, this bit is a logic “0”. In FIFO mode this bit is set along with bit 2 when a timeout interrupt is pending.

Bits 4 and 5

These bits of the IIR are always logic “0”.

Bits 6 and 7

These two bits are set when the FIFO CONTROL Register bit 0 equals 1.

BIT 7	BIT 6	RCVR FIFO TRIGGER LEVEL (BYTES)
0	0	1
0	1	4
1	0	8
1	1	14

Table 8.2 Interrupt Control

FIFO MODE ONLY	INTERRUPT IDENTIFICATION REGISTER			INTERRUPT SET AND RESET FUNCTIONS				
	BIT 3	BIT 2	BIT 1	BIT 0	PRIORITY LEVEL	INTERRUPT TYPE	INTERRUPT SOURCE	INTERRUPT RESET CONTROL
	0	0	0	1	-	None	None	-
	0	1	1	0	Highest	Receiver Line Status	Overrun Error, Parity Error, Framing Error or Break Interrupt	Reading the Line Status Register
	0	1	0	0	Second	Received Data Available	Receiver Data Available	Read Receiver Buffer or the FIFO drops below the trigger level.
	1	1	0	0	Second	Character Timeout Indication	No Characters Have Been Removed From or Input to the RCVR FIFO during the last 4 Char times and there is at least 1 char in it during this time	Reading the Receiver Buffer Register
	0	0	1	0	Third	Transmitter Holding Register Empty	Transmitter Holding Register Empty	Reading the IIR Register (if Source of Interrupt) or Writing the Transmitter Holding Register
	0	0	0	0	Fourth	MODEM Status	Clear to Send or Data Set Ready or Ring Indicator or Data Carrier Detect	Reading the MODEM Status Register

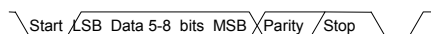
LINE CONTROL REGISTER (LCR)
Address Offset = 3H, DLAB = 0, READ/WRITE

Figure 8.1 Serial Data

Datasheet

This register contains the format information of the serial line. The bit definitions are:

Bits 0 and 1

These two bits specify the number of bits in each transmitted or received serial character. The encoding of bits 0 and 1 is as follows:

The Start, Stop and Parity bits are not included in the word length.

BIT 1	BIT 0	WORD LENGTH
0	0	5 Bits
0	1	6 Bits
1	0	7 Bits
1	1	8 Bits

Bit 2

This bit specifies the number of stop bits in each transmitted or received serial character. The following table summarizes the information.

BIT 2	WORD LENGTH	NUMBER OF STOP BITS
0	--	1
1	5 bits	1.5
1	6 bits	2
1	7 bits	2
1	8 bits	2

Note: The receiver will ignore all stop bits beyond the first, regardless of the number used in transmitting.

Bit 3

Parity Enable bit. When bit 3 is a logic "1", a parity bit is generated (transmit data) or checked (receive data) between the last data word bit and the first stop bit of the serial data. (The parity bit is used to generate an even or odd number of 1s when the data word bits and the parity bit are summed).

Bit 4

Even Parity Select bit. When bit 3 is a logic "1" and bit 4 is a logic "0", an odd number of logic "1"s is transmitted or checked in the data word bits and the parity bit. When bit 3 is a logic "1" and bit 4 is a logic "1" an even number of bits is transmitted and checked.

Bit 5

This bit is the Stick Parity bit. When parity is enabled it is used in conjunction with bit 4 to select Mark or Space Parity. When LCR bits 3, 4 and 5 are 1 the Parity bit is transmitted and checked as a 0 (Space Parity). If bits 3 and 5 are 1 and bit 4 is a 0, then the Parity bit is transmitted and checked as 1 (Mark Parity). If bit 5 is 0 Stick Parity is disabled.

Bit 6

Set Break Control bit. When bit 6 is a logic "1", the transmit data output (TXD) is forced to the Spacing or logic "0" state and remains there (until reset by a low level bit 6) regardless of other transmitter activity. This feature enables the Serial Port to alert a terminal in a communications system.

Bit 7

Divisor Latch Access bit (DLAB). It must be set high (logic “1”) to access the Divisor Latches of the Baud Rate Generator during read or write operations. It must be set low (logic “0”) to access the Receiver Buffer Register, the Transmitter Holding Register, or the Interrupt Enable Register.

MODEM CONTROL REGISTER (MCR)

Address Offset = 4H, DLAB = X, READ/WRITE

This 8 bit register controls the interface with the MODEM or data set (or device emulating a MODEM). The contents of the MODEM control register are described below.

Bit 0

This bit controls the Data Terminal Ready (nDTR) output. When bit 0 is set to a logic “1”, the nDTR output is forced to a logic “0”. When bit 0 is a logic “0”, the nDTR output is forced to a logic “1”.

Bit 1

This bit controls the Request To Send (nRTS) output. Bit 1 affects the nRTS output in a manner identical to that described above for bit 0.

Bit 2

This bit controls the Output 1 (OUT1) bit. This bit does not have an output pin and can only be read or written by the CPU.

Bit 3

Output 2 (OUT2). This bit is used to enable an UART interrupt. When OUT2 is a logic “0”, the serial port interrupt output is forced to a high impedance state - disabled. When OUT2 is a logic “1”, the serial port interrupt outputs are enabled.

Bit 4

This bit provides the loopback feature for diagnostic testing of the Serial Port. When bit 4 is set to logic “1”, the following occur:

1. The TXD is set to the Marking State (logic “1”).
2. The receiver Serial Input (RXD) is disconnected.
3. The output of the Transmitter Shift Register is “looped back” into the Receiver Shift Register input.
4. All MODEM Control inputs (nCTS, nDSR, nRI and nDCD) are disconnected.
5. The four MODEM Control outputs (nDTR, nRTS, OUT1 and OUT2) are internally connected to the four MODEM Control inputs (nDSR, nCTS, RI, DCD).
6. The Modem Control output pins are forced inactive high.
7. Data that is transmitted is immediately received.

This feature allows the processor to verify the transmit and receive data paths of the Serial Port. In the diagnostic mode, the receiver and the transmitter interrupts are fully operational. The MODEM Control Interrupts are also operational but the interrupts’ sources are now the lower four bits of the MODEM Control Register instead of the MODEM Control inputs. The interrupts are still controlled by the Interrupt Enable Register.

Bits 5 through 7

These bits are permanently set to logic zero.

Datasheet**LINE STATUS REGISTER (LSR)****Address Offset = 5H, DLAB = X, READ/WRITE****Bit 0**

Data Ready (DR). It is set to a logic “1” whenever a complete incoming character has been received and transferred into the Receiver Buffer Register or the FIFO. Bit 0 is reset to a logic “0” by reading all of the data in the Receive Buffer Register or the FIFO.

Bit 1

Overrun Error (OE). Bit 1 indicates that data in the Receiver Buffer Register was not read before the next character was transferred into the register, thereby destroying the previous character. In FIFO mode, an overrun error will occur only when the FIFO is full and the next character has been completely received in the shift register, the character in the shift register is overwritten but not transferred to the FIFO. The OE indicator is set to a logic “1” immediately upon detection of an overrun condition, and reset whenever the Line Status Register is read.

Bit 2

Parity Error (PE). Bit 2 indicates that the received data character does not have the correct even or odd parity, as selected by the even parity select bit. The PE is set to a logic “1” upon detection of a parity error and is reset to a logic “0” whenever the Line Status Register is read. In the FIFO mode this error is associated with the particular character in the FIFO it applies to. This error is indicated when the associated character is at the top of the FIFO.

Bit 3

Framing Error (FE). Bit 3 indicates that the received character did not have a valid stop bit. Bit 3 is set to a logic “1” whenever the stop bit following the last data bit or parity bit is detected as a zero bit (Spacing level). The FE is reset to a logic “0” whenever the Line Status Register is read. In the FIFO mode this error is associated with the particular character in the FIFO it applies to. This error is indicated when the associated character is at the top of the FIFO. The Serial Port will try to resynchronize after a framing error. To do this, it assumes that the framing error was due to the next start bit, so it samples this ‘start’ bit twice and then takes in the ‘data’.

Bit 4

Break Interrupt (BI). Bit 4 is set to a logic “1” whenever the received data input is held in the Spacing state (logic “0”) for longer than a full word transmission time (that is, the total time of the start bit + data bits + parity bits + stop bits). The BI is reset after the CPU reads the contents of the Line Status Register. In the FIFO mode this error is associated with the particular character in the FIFO it applies to. This error is indicated when the associated character is at the top of the FIFO. When break occurs only one zero character is loaded into the FIFO. Restarting after a break is received, requires the serial data (RXD) to be logic “1” for at least ½ bit time.

Note: Bits 1 through 4 are the error conditions that produce a Receiver Line Status Interrupt whenever any of the corresponding conditions are detected and the interrupt is enabled.

Bit 5

Transmitter Holding Register Empty (THRE). Bit 5 indicates that the Serial Port is ready to accept a new character for transmission. In addition, this bit causes the Serial Port to issue an interrupt when the Transmitter Holding Register interrupt enable is set high. The THRE bit is set to a logic “1” when a character is transferred from the Transmitter Holding Register into the Transmitter Shift Register. The bit is reset to logic “0” whenever the CPU loads the Transmitter Holding Register. In the FIFO mode this bit is set when the XMIT FIFO is empty, it is cleared when at least 1 byte is written to the XMIT FIFO. Bit 5 is a read only bit.

Bit 6

Transmitter Empty (TEMT). Bit 6 is set to a logic “1” whenever the Transmitter Holding Register (THR) and Transmitter Shift Register (TSR) are both empty. It is reset to logic “0” whenever either the THR

or TSR contains a data character. Bit 6 is a read only bit. In the FIFO mode this bit is set whenever the THR and TSR are both empty,

Bit 7

This bit is permanently set to logic "0" in the 450 mode. In the FIFO mode, this bit is set to a logic "1" when there is at least one parity error, framing error or break indication in the FIFO. This bit is cleared when the LSR is read if there are no subsequent errors in the FIFO.

MODEM STATUS REGISTER (MSR)

Address Offset = 6H, DLAB = X, READ/WRITE

This 8 bit register provides the current state of the control lines from the MODEM (or peripheral device). In addition to this current state information, four bits of the MODEM Status Register (MSR) provide change information. These bits are set to logic "1" whenever a control input from the MODEM changes state. They are reset to logic "0" whenever the MODEM Status Register is read.

Bit 0

Delta Clear To Send (DCTS). Bit 0 indicates that the nCTS input to the chip has changed state since the last time the MSR was read.

Bit 1

Delta Data Set Ready (DDSR). Bit 1 indicates that the nDSR input has changed state since the last time the MSR was read.

Bit 2

Trailing Edge of Ring Indicator (TERI). Bit 2 indicates that the nRI input has changed from logic "0" to logic "1".

Bit 3

Delta Data Carrier Detect (DDCD). Bit 3 indicates that the nDCD input to the chip has changed state.

Note: Whenever bit 0, 1, 2, or 3 is set to a logic "1", a MODEM Status Interrupt is generated.

Bit 4

This bit is the complement of the Clear To Send (nCTS) input. If bit 4 of the MCR is set to logic "1", this bit is equivalent to nRTS in the MCR.

Bit 5

This bit is the complement of the Data Set Ready (nDSR) input. If bit 4 of the MCR is set to logic "1", this bit is equivalent to DTR in the MCR.

Bit 6

This bit is the complement of the Ring Indicator (nRI) input. If bit 4 of the MCR is set to logic "1", this bit is equivalent to OUT1 in the MCR.

Bit 7

This bit is the complement of the Data Carrier Detect (nDCD) input. If bit 4 of the MCR is set to logic "1", this bit is equivalent to OUT2 in the MCR.

SCRATCHPAD REGISTER (SCR)

Address Offset =7H, DLAB =X, READ/WRITE

This 8 bit read/write register has no effect on the operation of the Serial Port. It is intended as a scratchpad register to be used by the programmer to hold data temporarily.

Datasheet**PROGRAMMABLE BAUD RATE GENERATOR (AND DIVISOR LATCHES DLH, DLL)**

The Serial Port contains a programmable Baud Rate Generator that is capable of dividing the internal PLL clock by any divisor from 1 to 65535. The internal PLL clock is divided down to generate a 1.8462MHz frequency for Baud Rates less than 38.4k, a 1.8432MHz frequency for 115.2k, a 3.6864MHz frequency for 230.4k and a 7.3728MHz frequency for 460.8k. This output frequency of the Baud Rate Generator is 16x the Baud rate. Two 8 bit latches store the divisor in 16 bit binary format. These Divisor Latches must be loaded during initialization in order to insure desired operation of the Baud Rate Generator. Upon loading either of the Divisor Latches, a 16 bit Baud counter is immediately loaded. This prevents long counts on initial load. If a 0 is loaded into the BRG registers the output divides the clock by the number 3. If a 1 is loaded the output is the inverse of the input oscillator. If a two is loaded the output is a divide by 2 signal with a 50% duty cycle. If a 3 or greater is loaded the output is low for 2 bits and high for the remainder of the count. The input clock to the BRG is a 1.8462 MHz clock.

[Table 8.4 on page 87](#) shows the baud rates possible.

EFFECT OF THE RESET ON THE REGISTER FILE

The Reset Function (details the effect of the Reset input on each of the registers of the Serial Port.

FIFO INTERRUPT MODE OPERATION

When the RCVR FIFO and receiver interrupts are enabled (FCR bit 0 = "1", IER bit 0 = "1"), RCVR interrupts occur as follows:

- The receive data available interrupt will be issued when the FIFO has reached its programmed trigger level; it is cleared as soon as the FIFO drops below its programmed trigger level.
- The IIR receive data available indication also occurs when the FIFO trigger level is reached. It is cleared when the FIFO drops below the trigger level.
- The receiver line status interrupt (IIR=06H), has higher priority than the received data available (IIR=04H) interrupt.
- The data ready bit (LSR bit 0) is set as soon as a character is transferred from the shift register to the RCVR FIFO. It is reset when the FIFO is empty.

When RCVR FIFO and receiver interrupts are enabled, RCVR FIFO timeout interrupts occur as follows:

- A FIFO timeout interrupt occurs if all the following conditions exist:

At least one character is in the FIFO.

The most recent serial character received was longer than 4 continuous character times ago. (If 2 stop bits are programmed, the second one is included in this time delay).

The most recent CPU read of the FIFO was longer than 4 continuous character times ago.

This will cause a maximum character received to interrupt issued delay of 160 msec at 300 BAUD with a 12-bit character.

- Character times are calculated by using the RCLK input for a clock signal (this makes the delay proportional to the baud rate).
- When a timeout interrupt has occurred it is cleared and the timer reset when the CPU reads one character from the RCVR FIFO.
- When a timeout interrupt has not occurred the timeout timer is reset after a new character is received or after the CPU reads the RCVR FIFO.

When the XMIT FIFO and transmitter interrupts are enabled (FCR bit 0 = "1", IER bit 1 = "1"), XMIT interrupts occur as follows:

- The transmitter holding register interrupt (02H) occurs when the XMIT FIFO is empty; it is cleared as soon as the transmitter holding register is written to (1 of 16 characters may be written to the XMIT FIFO while servicing this interrupt) or the IIR is read.

- The transmitter FIFO empty indications will be delayed 1 character time minus the last stop bit time whenever the following occurs: THRE=1 and there have not been at least two bytes at the same time in the transmitter FIFO since the last THRE=1. The transmitter interrupt after changing FCR0 will be immediate, if it is enabled.

Character timeout and RCVR FIFO trigger level interrupts have the same priority as the current received data available interrupt; XMIT FIFO empty has the same priority as the current transmitter holding register empty interrupt.

FIFO POLLED MODE OPERATION

With FCR bit 0 = "1" resetting IER bits 0, 1, 2 or 3 or all to zero puts the UART in the FIFO Polled Mode of operation. Since the RCVR and XMITTER are controlled separately, either one or both can be in the polled mode of operation. In this mode, the user's program will check RCVR and XMITTER status via the LSR. LSR definitions for the FIFO Polled Mode are as follows:

Bit 0=1 as long as there is one byte in the RCVR FIFO.

Bits 1 to 4 specify which error(s) have occurred. Character error status is handled the same way as when in the interrupt mode, the IIR is not affected since EIR bit 2=0.

Bit 5 indicates when the XMIT FIFO is empty.

Bit 6 indicates that both the XMIT FIFO and shift register are empty.

Bit 7 indicates whether there are any errors in the RCVR FIFO.

There is no trigger level reached or timeout condition indicated in the FIFO Polled Mode, however, the RCVR and XMIT FIFOs are still fully capable of holding characters.

FREQUENCY SELECTION

Each Serial Port mode register (at offset 0xF0 in Logical devices 0x4, 0x5, 0xB - 0xE) the frequency is selected as shown in [Table 8.3](#).

Table 8.3 Serial Ports Mode Register

Serial Port 1-6 Mode Register Default = 0x00 on VCC POR, VTR POR and PCI RESET	0xF0 R/W In all of the SP Logical Devices	Bit[0] MIDI Mode = 0 MIDI support disabled (default) = 1 MIDI support enabled Bit[1] High Speed = 0 High Speed Disabled (default) = 1 High Speed Enabled Bit [3:2] Enhanced Frequency Select = 00 Standard Mode (default) = 01 Select 921K = 10 Select 1.5M = 11 Reserved Bit[7:4] Refer to Section 8.2, "Interrupt Sharing" for more detail.
---	--	--

[Figure 8.2](#) illustrates the effect of programming bits[3:0] of the Mode register (at offset 0xF0 in the respective logical device) on the Baud rate. [Table 8.4](#) summarizes this functionality.

Table 8.4 Baud Rates

DESIRED BAUD RATE	DIVISOR USED TO GENERATE 16X CLOCK	PERCENT ERROR DIFFERENCE BETWEEN DESIRED AND ACTUAL Note 8.2	MIDI MODE BIT[0]	HIGH SPEED BIT BIT[1]	ENHANCED FREQUENCY SELECT BIT[3:2]
50	2304	0.001	0	0	00
75	1536	-	0	0	00
110	1047	-	0	0	00
134.5	857	0.004	0	0	00
150	768	-	0	0	00
300	384	-	0	0	00
600	192	-	0	0	00
1200	96	-	0	0	00
1800	64	-	0	0	00
2000	58	0.005	0	0	00
2400	48	-	0	0	00
3600	32	-	0	0	00
4800	24	-	0	0	00
7200	16	-	0	0	00
9600	12	-	0	0	00
19200	6	-	0	0	00
38400	3	0.030	0	0	00
57600	2	0.16	0	0	00
115200	1	0.16	0	0	00
230400	2	0.16	0	1	00
460800	1	0.16	0	1	00
921600	1	0.16	0	1	01
1500000	1	0.16	0	0	1X
31250 (Note 8.1)	4	0.16	1	0	00

Note 8.1 31250 KHz is the MIDI frequency. It is possible to program other baud rates when the MIDI bit is set by changing the divisor register, but the device will not be midi compliant.

Note 8.2 The percentage error for all baud rates, except where indicated otherwise, is 0.2%.

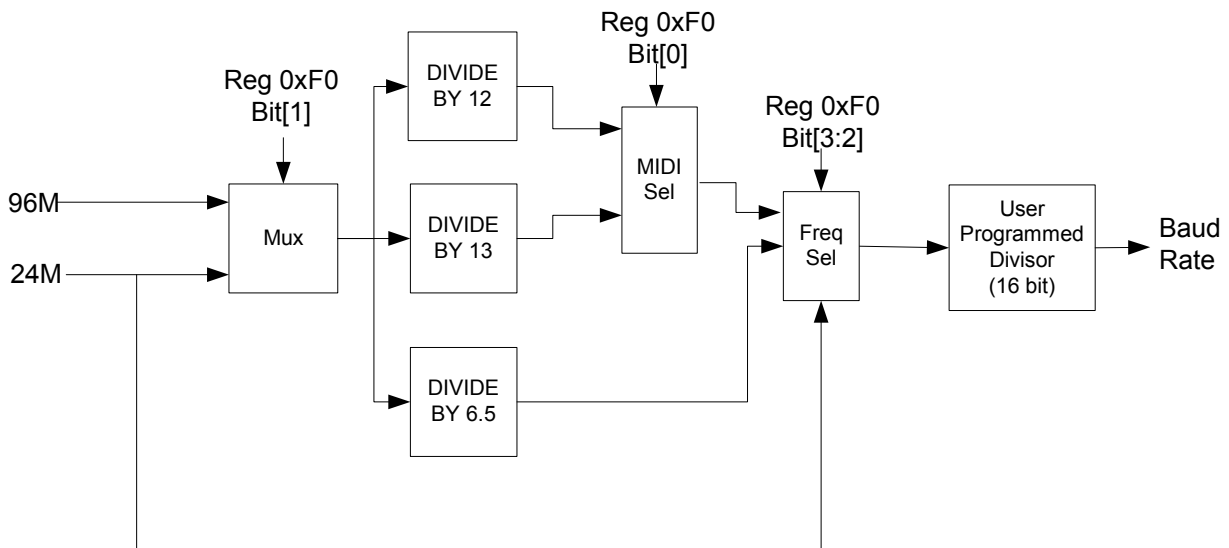
Figure 8.2 Baud Rate Selection
Table 8.5 register Reset

REGISTER BIT	RESET CONTROL	RESET STATE
Interrupt Enable Register	RESET	All bits low
Interrupt Identification Reg.	RESET	Bit 0 is high; Bits 1 - 7 low
FIFO Control	RESET	All bits low
Line Control Reg.	RESET	All bits low
MODEM Control Reg.	RESET	All bits low
Line Status Reg.	RESET	All bits low except 5, 6 high
MODEM Status Reg.	RESET	Bits 0 - 3 low; Bits 4 - 7 input
INTRPT (RCVR errs)	RESET/Read LSR	Low
INTRPT (RCVR Data Ready)	RESET/Read RBR	Low
INTRPT (THRE)	RESET/Read IIR/Write THR	Low
RCVR FIFO	RESET/ FCR1*FCR0/_FCR0	All Bits Low
XMIT FIFO	RESET/ FCR1*FCR0/_FCR0	All Bits Low

Table 8.6 Pin Reset

PIN SIGNAL	RESET CONTROL	RESET STATE
TXDn	RESET	High-Z (Note 8.3)
nRTSx	RESET	High-Z (Note 8.3)
nDTRx	RESET	High-Z (Note 8.3)

Datasheet

Note 8.3 Serial ports 1 and 2 may be placed in the powerdown mode by clearing the associated activate bit located at CR30 or by clearing the associated power bit located in the Power Control register at CR22. Serial ports 3,4,5,6 (if available) may be placed in the powerdown mode by clearing the associated activate bit located at CR30. When in the powerdown mode, the serial port outputs are tristated. In cases where the serial port is multiplexed as an alternate function, the corresponding output will only be tristated if the serial port is the selected alternate function.

Table 8.7 Register Summary for an Individual UART Channel

REGISTER ADDRESS (Note 8.4)	REGISTER NAME	REGISTER SYMBOL	BIT 7	BIT 6	BIT 5	BIT 4	BIT 3	BIT 2	BIT 1	BIT 0
ADDR = 0 DLAB = 0	Receive Buffer Register (Read Only)	RBR	Data Bit 7	Data Bit 6	Data Bit 5	Data Bit 4	Data Bit 3	Data Bit 2	Data Bit 1	Data Bit 0 (Note 8.5)
ADDR = 0 DLAB = 0	Transmitter Holding Register (Write Only)	THR	Data Bit 7	Data Bit 6	Data Bit 5	Data Bit 4	Data Bit 3	Data Bit 2	Data Bit 1	Data Bit 0
ADDR = 1 DLAB = 0	Interrupt Enable Register	IER	0	0	0	0	Enable MODEM Status Interrupt (EMSI)	Enable Receiver Line Status Interrupt (ELSI)	Enable Transmitter Holding Register Empty Interrupt (ETHREI)	Enable Received Data Available Interrupt (ERDAI)
ADDR = 2	Interrupt Ident. Register (Read Only)	IIR	FIFOs Enabled (Note 8.9)	FIFOs Enabled (Note 6)	0	0	Interrupt ID Bit (Note 8.9)	Interrupt ID Bit	Interrupt ID Bit	"0" if Interrupt Pending
ADDR = 2	FIFO Control Register (Write Only)	FCR (Note 8.11)	RCVR Trigger MSB	RCVR Trigger LSB	Reserved	Reserved	DMA Mode Select (Note 8.10)	XMIT FIFO Reset	RCVR FIFO Reset	FIFO Enable
ADDR = 3	Line Control Register	LCR	Divisor Latch Access Bit (DLAB)	Set Break	Stick Parity	Even Parity Select (EPS)	Parity Enable (PEN)	Number of Stop Bits (STB)	Word Length Select Bit 1 (WLS1)	Word Length Select Bit 0 (WLS0)
ADDR = 4	MODEM Control Register	MCR	0	0	0	Loop	OUT2 (Note 8.7)	OUT1 (Note 8.7)	Request to Send (RTS)	Data Terminal Ready (DTR)
ADDR = 5	Line Status Register	LSR	Error in RCVR FIFO (Note 8.9)	Transmitter Empty (TEMPT) (Note 8.6)	Transmitter Holding Register (THRE)	Break Interrupt (BI)	Framing Error (FE)	Parity Error (PE)	Overrun Error (OE)	Data Ready (DR)

Table 8.7 Register Summary for an Individual UART Channel (continued)

REGISTER ADDRESS (Note 8.4)	REGISTER NAME	REGISTER SYMBOL	BIT 7	BIT 6	BIT 5	BIT 4	BIT 3	BIT 2	BIT 1	BIT 0
ADDR = 6	MODEM Status Register	MSR	Data Carrier Detect (DCD)	Ring Indicator (RI)	Data Set Ready (DSR)	Clear to Send (CTS)	Delta Data Carrier Detect (DDCD)	Trailing Edge Ring Indicator (TERI)	Delta Data Set Ready (DDSR)	Delta Clear to Send (DCTS)
ADDR = 7	Scratch Register (Note 8.8)	SCR	Bit 7	Bit 6	Bit 5	Bit 4	Bit 3	Bit 2	Bit 1	Bit 0
ADDR = 0 DLAB = 1	Divisor Latch (LS)	DDL	Bit 7	Bit 6	Bit 5	Bit 4	Bit 3	Bit 2	Bit 1	Bit 0
ADDR = 1 DLAB = 1	Divisor Latch (MS)	DLM	Bit 15	Bit 14	Bit 13	Bit 12	Bit 11	Bit 10	Bit 9	Bit 8
<p>Note 8.4 DLAB is Bit 7 of the Line Control Register (ADDR = 3).</p> <p>Note 8.5 Bit 0 is the least significant bit. It is the first bit serially transmitted or received.</p> <p>Note 8.6 When operating in the XT mode, this bit will be set any time that the transmitter shift register is empty.</p> <p>Note 8.7 This bit no longer has a pin associated with it.</p> <p>Note 8.8 When operating in the XT mode, this register is not available.</p> <p>Note 8.9 These bits are always zero in the non-FIFO mode.</p> <p>Note 8.10 Writing a one to this bit has no effect. DMA modes are not supported in this chip.</p> <p>Note 8.11 The UARTs FCR's are shadowed UART FIFO Control Shadow Registers. See Chapter 26, Runtime Register for more details.</p>										

NOTES ON SERIAL PORT OPERATION

FIFO Mode Operation:

General

The RCVR FIFO will hold up to 16 bytes regardless of which trigger level is selected.

TX AND RX FIFO OPERATION

The Tx portion of the UART transmits data through TXD as soon as the CPU loads a byte into the Tx FIFO. **The UART will prevent loads to the Tx FIFO if it currently holds 16 characters.** Loading to the Tx FIFO will again be enabled as soon as the next character is transferred to the Tx shift register. These capabilities account for the largely autonomous operation of the Tx.

The UART starts the above operations typically with a Tx interrupt. The chip issues a Tx interrupt whenever the Tx FIFO is empty and the Tx interrupt is enabled, except in the following instance. Assume that the Tx FIFO is empty and the CPU starts to load it. When the first byte enters the FIFO the Tx FIFO empty interrupt will transition from active to inactive. Depending on the execution speed of the service routine software, the UART may be able to transfer this byte from the FIFO to the shift register before the CPU loads another byte. If this happens, the Tx FIFO will be empty again and typically the UART's interrupt line would transition to the active state. This could cause a system with an interrupt control unit to record a Tx FIFO empty condition, even though the CPU is currently servicing that interrupt. **Therefore, after the first byte has been loaded into the FIFO the UART will wait one serial character transmission time before issuing a new Tx FIFO empty interrupt. This one character Tx interrupt delay will remain active until at least two bytes have been loaded into the FIFO, concurrently. When the Tx FIFO empties after this condition, the Tx interrupt will be activated without a one character delay.**

Rx support functions and operation are quite different from those described for the transmitter. The Rx FIFO receives data until the number of bytes in the FIFO equals the selected interrupt trigger level. At that time if Rx interrupts are enabled, the UART will issue an interrupt to the CPU. The Rx FIFO will continue to store bytes until it holds 16 of them. It will not accept any more data when it is full. Any more data entering the Rx shift register will set the Overrun Error flag. Normally, the FIFO depth and the programmable trigger levels will give the CPU ample time to empty the Rx FIFO before an overrun occurs.

One side-effect of having a Rx FIFO is that the selected interrupt trigger level may be above the data level in the FIFO. This could occur when data at the end of the block contains fewer bytes than the trigger level. No interrupt would be issued to the CPU and the data would remain in the UART. **To prevent the software from having to check for this situation the chip incorporates a timeout interrupt.**

The timeout interrupt is activated when there is a least one byte in the Rx FIFO, and neither the CPU nor the Rx shift register has accessed the Rx FIFO within 4 character times of the last byte. The timeout interrupt is cleared or reset when the CPU reads the Rx FIFO or another character enters it.

These FIFO related features allow optimization of CPU/UART transactions and are especially useful given the higher baud rate capability (256 kbaud).

TXD2 PIN

The TXD2 signal is located on the GP53/TXD2(IRTx) pin. The operation of this pin following a power cycle is defined in [Section 8.1.1, "IR Transmit Pin," on page 93](#).

8.1 Infrared Interface

The infrared interface provides a two-way wireless communications port using infrared as a transmission medium. Two IR implementations have been provided for the second UART in this chip (logical device 5), IrDA and Amplitude Shift Keyed IR. The IR transmission can use the standard UART2 TXD2 and RXD2 pins. These can be selected through the configuration registers.

Datasheet

IrDA 1.0 allows serial communication at baud rates up to 115.2 kbps. Each word is sent serially beginning with a zero value start bit. A zero is signaled by sending a single IR pulse at the beginning of the serial bit time. A one is signaled by sending no IR pulse during the bit time. Please refer to the AC timing for the parameters of these pulses and the IrDA waveform.

The Amplitude Shift Keyed IR allows asynchronous serial communication at baud rates up to 19.2K Baud. Each word is sent serially beginning with a zero value start bit. A zero is signaled by sending a 500KHz waveform for the duration of the serial bit time. A one is signaled by sending no transmission during the bit time. Please refer to the AC timing for the parameters of the ASK-IR waveform.

If the Half Duplex option is chosen, there is a time-out when the direction of the transmission is changed. This time-out starts at the last bit transferred during a transmission and blocks the receiver input until the timeout expires. If the transmit buffer is loaded with more data before the time-out expires, the timer is restarted after the new byte is transmitted. If data is loaded into the transmit buffer while a character is being received, the transmission will not start until the time-out expires after the last receive bit has been received. If the start bit of another character is received during this time-out, the timer is restarted after the new character is received. The IR half duplex time-out is programmable via CRF2 in Logical Device 5. This register allows the time-out to be programmed to any value between 0 and 10msec in 100usec increments.

The following figure shows the block diagram of the IR components in the SCH311X:

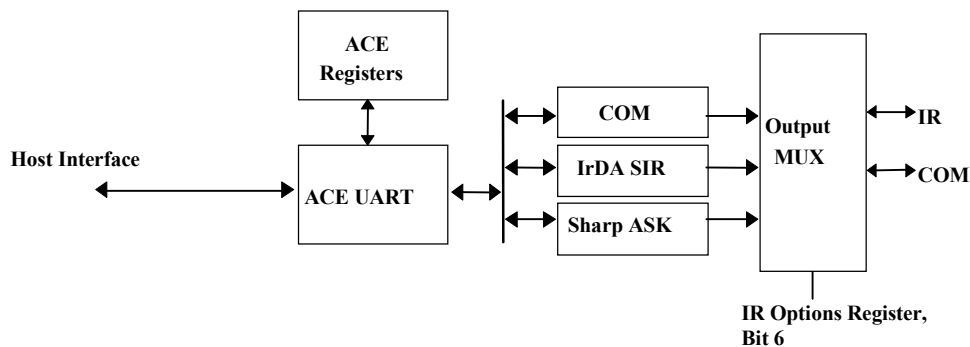

8.1.1 IR Transmit Pin

The following description describes the state of the GP53/TXD2(IRTX) pin following a power cycle.

GP53/TXD2(IRTX) Pin. This pin defaults to the GPIO input function on a VTR POR.

The GP53/TXD2(IRTX) pin will be tristate following a VCC POR, VTR POR, Soft Reset, or PCI Reset when it is configured for the TXD2 (IRTX) function. It will remain tristate until the UART is powered. Once the UART is powered, the state of the pin will be determined by the UART block. If VCC>2.4V and GP53 function is selected the pin will reflect the current state of GP53.

Note: External hardware should be implemented to protect the transceiver when the IRTX2 pin is tristated.

8.2 Interrupt Sharing

Multiple sharing options are available are for the SCH311X devices. Sharing an interrupt requires the following:

1. Configure the UART to be the generator to the desired IRQ.
2. Configure other shared UARTs to use No IRQ selected.
3. Set the desired share IRQ bit.

APPLICATION NOTE: If both UARTs are configured to use different IRQs and the share IRQ bit is set, then both of the UART IRQs will assert when either UART generates an interrupt.

Table 8.8, summarizes the various IRQ sharing configurations. In this table, the following nomenclature is used:

- N/A - not applicable
- NS - port not shared
- S12 - uart 1 and uart 2 share an IRQ
- S34 - uart 3 and uart 4 share an IRQ
- S56 - uart 5 and uart 6 share an IRQ
- S1234 - UARTS 1,2,3,4 share the same IRQ
- S1256 - UARTS 1,2,5,6 share the same IRQ
- S3456 - UARTS 3,4,5,6 share the same IRQ
- S123456 - all uarts share the same IRQ

Table 8.8 SCH311X IRQ Sharing Summary

DEVICE	SP1 MODE REG (0XF0) BIT6 ALL SHARE BIT Table 25.1 2 on page 286	SP1 MODE REG (0XF0) BIT7 SP12 SHARE BIT Table 25.1 2 on page 286	SP3 MODE REG (0XF0) BIT7 SP34 SHARE BIT Table 25.1 6 on page 289	SP5 MODE REG (0XF0) BIT7 SP56 SHARE BIT Table 25.1 8 on page 290	SP1	SP2	SP3	SP4	SP5	SP6
SCH3112	0	0	N/A	N/A	NS	NS	N/A	N/A	N/A	N/A
	0	1	N/A	N/A	S12	S12	N/A	N/A	N/A	N/A
	1	0	N/A	N/A	NS	NS	N/A	N/A	N/A	N/A
	1	1	N/A	N/A	S12	S12	N/A	N/A	N/A	N/A
SCH3114	0	0	0	N/A	NS	NS	NS	NS	N/A	N/A
	0	1	0	N/A	S12	S12	NS	NS	N/A	N/A
	0	0	1	N/A	NS	NS	S34	S34	N/A	N/A
	0	1	1	N/A	S12	S12	S34	S34	N/A	N/A
	1	0	0	N/A	NS	NS	NS	NS	N/A	N/A
	1	1	0	N/A	S12	S12	NS	NS	N/A	N/A
	1	0	1	N/A	NS	NS	S34	S34	N/A	N/A
1	1	1	N/A	S12 34	S12 34	S12 34	S12 34	N/A	N/A	

Table 8.8 SCH311X IRQ Sharing Summary (continued)

DEVICE	SP1 MODE REG (0XF0) BIT6 ALL SHARE BIT Table 25.1 2 on page 286	SP1 MODE REG (0XF0) BIT7 SP12 SHARE BIT Table 25.1 2 on page 286	SP3 MODE REG (0XF0) BIT7 SP34 SHARE BIT Table 25.1 6 on page 289	SP5 MODE REG (0XF0) BIT7 SP56 SHARE BIT Table 25.1 8 on page 290	SP1	SP2	SP3	SP4	SP5	SP6
SCH3116	0	0	0	0	NS	NS	NS	NS	NS	NS
	0	1	0	0	S12	S12	NS	NS	NS	NS
	0	0	1	0	NS	NS	S34	S34	NS	NS
	0	1	1	0	S12	S12	S34	S34	NS	NS
	0	0	0	1	NS	NS	NS	NS	S56	S56
	0	1	0	1	S12	S12	NS	NS	S56	S56
	0	0	1	1	NS	NS	S34	S34	S56	S56
	0	1	1	1	S12	S12	S34	S34	S56	S56
	1	0	0	0	NS	NS	NS	NS	NS	NS
	1	1	0	0	S12	S12	NS	NS	NS	NS
	1	0	1	0	NS	NS	S34	S34	NS	NS
	1	1	1	0	S12 34	S12 34	S12 34	S12 34	NS	NS
	1	0	0	1	NS	NS	NS	NS	S56	S56
	1	1	0	1	S12 56	S12 56	NS	NS	S12 56	S12 56
	1	0	1	1	NS	NS	S34 56	S34 56	S34 56	S34 56
	1	1	1	1	S12 345 6	S12 345 6	S12 345 6	S12 345 6	S12 345 6	S12 345 6

8.3 RS485 Auto Direction Control

The purpose of this function is to save the effort to deal with direction control in software. A direction control signal (usually nRTS) is used to tristate the transmitter when no other data is available, so that other nodes can use the shared lines. It is preferred to have this function on all six serial ports.

This will affect the nRTS and nDTR signals for each serial port in the device. Each serial port will have the following additional characteristics:

- An option register for the serial port in the runtime registers with following bits:

An enable bit to turn on/off the direction control

An enable bit to select which bit nRTS or nDTR, of the serial port is affected.

A bit to select the polarity - high or low, that the selected signal is driven to when the output buffer of the corresponding serial port is empty or full.

- When automatic direction control is enabled, the device monitors the local output buffer for not empty and empty conditions. If enabled, the direction control will force the nRTS or nDTR signal (selected via programming) to the desired polarity under the empty or not empty condition. [Table 8.9](#) summarizes the possible programming states.
- Automatic Direction Control of the serial ports is only valid when the FIFO is enabled.
- The multi-function GPIO pins do not automatically set the direction when selected as serial port pins.
- The high speed baud rates will only work if the MSB of the MS divisor is set.

Table 8.9 nRTS/nDTR Automatic Direction Control Options

LOCAL TX BUFFER STATE	FLOW COUNT EN BIT	NRTS/NDTR SEL BIT	POLARITY SEL BIT	NRTS	NDTR
X	0	X	X	N/A	N/A
empty	1	1	0	0	N/A
empty	1	1	1	1	N/A
not empty	1	1	0	1	N/A
not empty	1	1	1	0	N/A
empty	1	0	0	N/A	0
empty	1	0	1	N/A	1
not empty	1	0	0	N/A	1
not empty	1	0	1	N/A	0

Note: Note that N/A indicates the signal is not affected under these conditions and maintains normal operation.

A typical application using HW automatic direction control is shown in the following [Figure 8.3 on page 97](#). In this figure the nRTS signal is used to control direction.

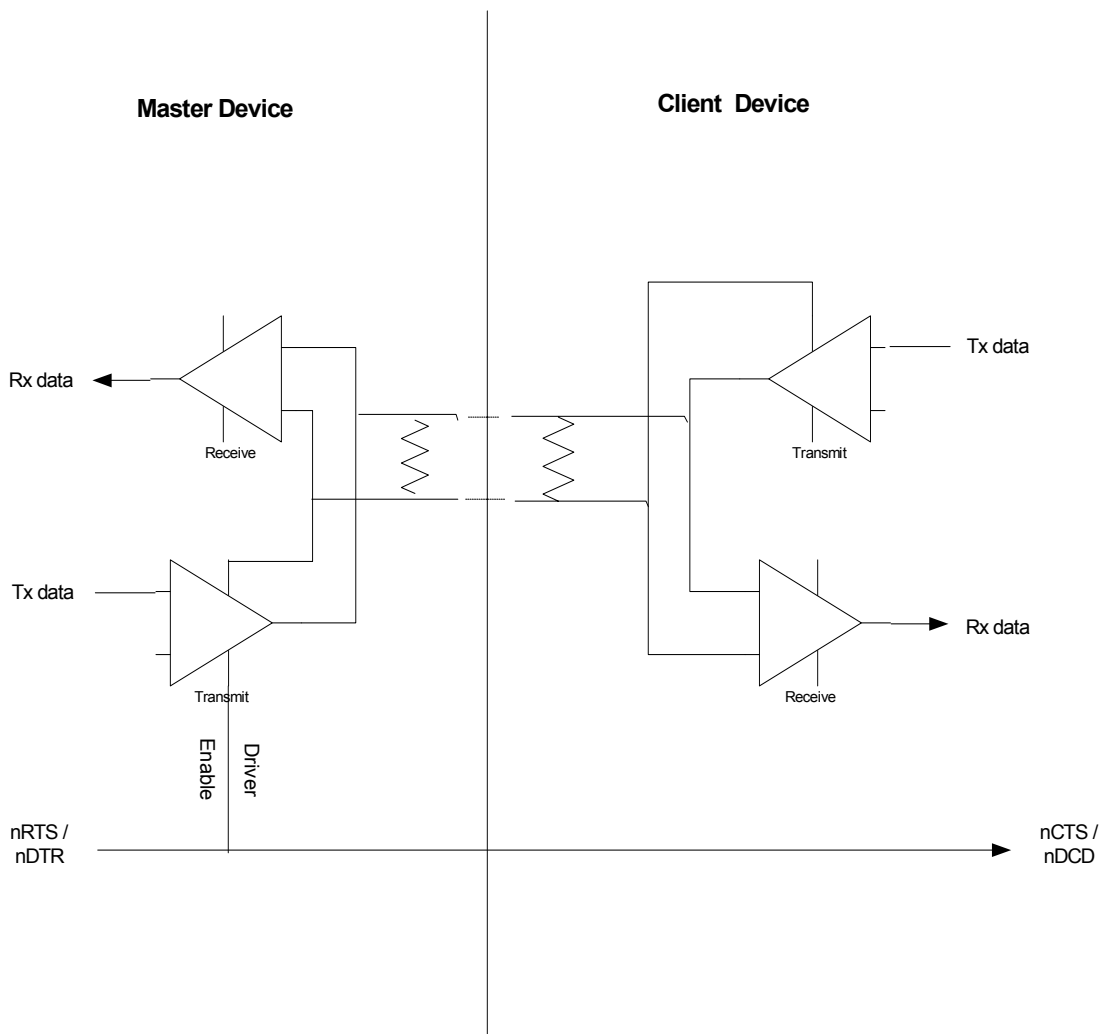

Figure 8.3 Half Duplex Operation with Direction Control

More detail on the programming of the autodirection control can be found in [Chapter 26, "Runtime Register," on page 293](#). SP12 is the option register for Serial Port 1 and 2. SP34 is the option register for Serial Port 3 and 4. SP5 is the option register for Serial Port 5. SP6 is the option register for Serial Port 6.

8.4 Reduced Pin Serial Ports (SCH3116 Only)

The SCH3116 contains two, 4 pin serial ports (5/6), which will have multiplexed control signals. For each 4 pin port, there is a transmit, receive, input control and output control. The selection of the input and output control is done via a bit in the SP5/6 option register. [Figure 8.4](#) illustrates the how programming these bits selects the corresponding control signals.

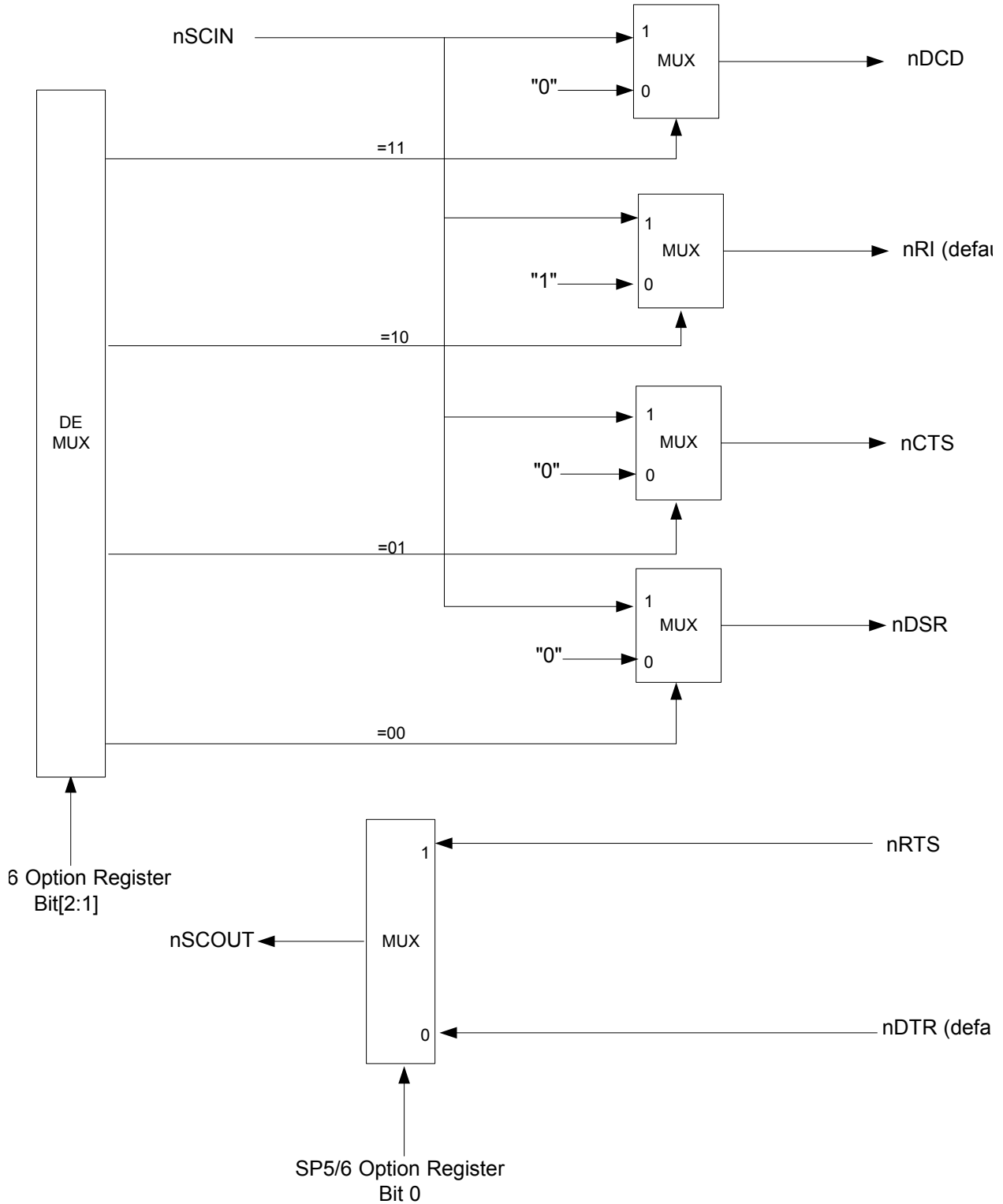

Figure 8.4 Reduce Pin Serial Port Control Signal Selection

For SP5, the port signals are nRTS5, nDTR5, nSCOUT5 and nSCIN5. The nSCOUT5 signal may be either nRTS5 or nDTR5, selected via an SP5 option bit in a register.



Datasheet

The nSCIN5 signal may be either the nDSR5, nCTS5, nRI5 or nDCD5 signals, as selected via a bit in the SP5 option register.

For SP6, the nSCOUT6 signal may be either nRTS6 or nDTR6, selected via SP6 option bit. The nSCIN6 signal may be either the nDSR6, nCTS6, nRI6 or nDCD6 signals, as selected via a bit in the SP6 option register. The programming for the SP5 and SP6 Option register is given in [Chapter 26, "Runtime Register," on page 293](#).



Datasheet

Chapter 9 Parallel Port

The SCH311X incorporates an IBM XT/AT compatible parallel port. This supports the optional PS/2 type bi-directional parallel port (SPP), the Enhanced Parallel Port (EPP) and the Extended Capabilities Port (ECP) parallel port modes. Refer to the Configuration Registers for information on disabling, power-down, changing the base address of the parallel port, and selecting the mode of operation.

The parallel port also incorporates SMSC's ChiProtect circuitry, which prevents possible damage to the parallel port due to printer power-up.

The functionality of the Parallel Port is achieved through the use of eight addressable ports, with their associated registers and control gating. The control and data port are read/write by the CPU, the status port is read/write in the EPP mode. The address map of the Parallel Port is shown below:

DATA PORT	BASE ADDRESS + 00H
STATUS PORT	BASE ADDRESS + 01H
CONTROL PORT	BASE ADDRESS + 02H
EPP ADDR PORT	BASE ADDRESS + 03H
EPP DATA PORT 0	BASE ADDRESS + 04H
EPP DATA PORT 1	BASE ADDRESS + 05H
EPP DATA PORT 2	BASE ADDRESS + 06H
EPP DATA PORT 3	BASE ADDRESS + 07H

The bit map of these registers is:

	D0	D1	D2	D3	D4	D5	D6	D7	NOTE
DATA PORT	PD0	PD1	PD2	PD3	PD4	PD5	PD6	PD7	1
STATUS PORT	TMOUT	0	0	nERR	SLCT	PE	nACK	nBUSY	1
CONTROL PORT	STROBE	AUTOFD	nINIT	SLC	IRQE	PCD	0	0	1
EPP ADDR PORT	PD0	PD1	PD2	PD3	PD4	PD5	PD6	PD7	2
EPP DATA PORT 0	PD0	PD1	PD2	PD3	PD4	PD5	PD6	PD7	2
EPP DATA PORT 1	PD0	PD1	PD2	PD3	PD4	PD5	PD6	PD7	2
EPP DATA PORT 2	PD0	PD1	PD2	PD3	PD4	PD5	PD6	PD7	2
EPP DATA PORT 3	PD0	PD1	PD2	PD3	PD4	PD5	PD6	PD7	2

Notes:

1. These registers are available in all modes.
2. These registers are only available in EPP mode.

Table 9.1 Parallel Port Connector

HOST CONNECTOR	PIN NUMBER	STANDARD	EPP	ECP
1	83	nSTROBE	nWrite	nStrobe
2-9	68-75	PD<0:7>	PData<0:7>	PData<0:7>
10	80	nACK	Intr	nAck
11	79	BUSY	nWait	Busy, PeriphAck(3)
12	78	PE	(User Defined)	PError, nAckReverse (3)
13	77	SLCT	(User Defined)	Select
14	82	nALF	nDataStb	nAutoFd, HostAck(3)
15	81	nERROR	(User Defined)	nFault (1) nPeriphRequest (3)
16	66	nINIT	nRESET	nInit(1) nReverseRqst(3)
17	67	nSLCTIN	nAddrstrb	nSelectIn(1,3)

(1) = Compatible Mode
(3) = High Speed Mode

Note: For the cable interconnection required for ECP support and the Slave Connector pin numbers, refer to the *IEEE 1284 Extended Capabilities Port Protocol and ISA Standard, Rev. 1.14*, July 14, 1993. This document is available from Microsoft.

9.1 IBM XT/AT Compatible, Bi-Directional and EPP Modes

DATA PORT

ADDRESS OFFSET = 00H

The Data Port is located at an offset of '00H' from the base address. The data register is cleared at initialization by RESET. During a WRITE operation, the Data Register latches the contents of the internal data bus. The contents of this register are buffered (non inverting) and output onto the PD0 - PD7 ports. During a READ operation in SPP mode, PD0 - PD7 ports are buffered (not latched) and output to the host CPU.

STATUS PORT

ADDRESS OFFSET = 01H

The Status Port is located at an offset of '01H' from the base address. The contents of this register are latched for the duration of a read cycle. The bits of the Status Port are defined as follows:

Bit 0 TMOUT - TIME OUT

This bit is valid in EPP mode only and indicates that a 10 usec time out has occurred on the EPP bus. A logic 0 means that no time out error has occurred; a logic 1 means that a time out error has been detected. This bit is cleared by a RESET. If the TIMEOUT_SELECT bit (bit 4 of the Parallel Port Mode Register 2, 0xF1 in Logical Device 3 Configuration Registers) is '0', writing a one to this bit clears the TMOUT status bit. Writing a zero to this bit has no effect. If the TIMEOUT_SELECT bit (bit 4 of the

Datasheet

Parallel Port Mode Register 2, 0xF1 in Logical Device 3 Configuration Registers) is '1', the TMOUT bit is cleared on the trailing edge of a read of the EPP Status Register.

Bits 1, 2 - are not implemented as register bits, during a read of the Printer Status Register these bits are a low level.

Bit 3 nERR – nERROR

The level on the nERROR input is read by the CPU as bit 3 of the Printer Status Register. A logic 0 means an error has been detected; a logic 1 means no error has been detected.

Bit 4 SLT - Printer Selected Status

The level on the SLCT input is read by the CPU as bit 4 of the Printer Status Register. A logic 1 means the printer is on line; a logic 0 means it is not selected.

Bit 5 PE - Paper End

The level on the PE input is read by the CPU as bit 5 of the Printer Status Register. A logic 1 indicates a paper end; a logic 0 indicates the presence of paper.

Bit 6 nACK - Acknowledge

The level on the nACK input is read by the CPU as bit 6 of the Printer Status Register. A logic 0 means that the printer has received a character and can now accept another. A logic 1 means that it is still processing the last character or has not received the data.

Bit 7 nBUSY - nBUSY

The complement of the level on the BUSY input is read by the CPU as bit 7 of the Printer Status Register. A logic 0 in this bit means that the printer is busy and cannot accept a new character. A logic 1 means that it is ready to accept the next character.

CONTROL PORT**ADDRESS OFFSET = 02H**

The Control Port is located at an offset of '02H' from the base address. The Control Register is initialized by the RESET input, bits 0 to 5 only being affected; bits 6 and 7 are hard wired low.

Bit 0 STROBE - Strobe

This bit is inverted and output onto the nSTROBE output.

Bit 1 AUTOFD - Autofeed

This bit is inverted and output onto the nAutoFd output. A logic 1 causes the printer to generate a line feed after each line is printed. A logic 0 means no autofeed.

Bit 2 nINIT - Initiate Output

This bit is output onto the nINIT output without inversion.

Bit 3 SLCTIN - Printer Select Input

This bit is inverted and output onto the nSLCTIN output. A logic 1 on this bit selects the printer; a logic 0 means the printer is not selected.

Bit 4 IRQE - Interrupt Request Enable

The interrupt request enable bit when set to a high level may be used to enable interrupt requests from the Parallel Port to the CPU. An interrupt request is generated on the IRQ port by a positive going nACK input. When the IRQE bit is programmed low the IRQ is disabled.

Bit 5 PCD - PARALLEL CONTROL DIRECTION

Parallel Control Direction is not valid in printer mode. In printer mode, the direction is always out regardless of the state of this bit. In bi-directional, EPP or ECP mode, a logic 0 means that the printer port is in output mode (write); a logic 1 means that the printer port is in input mode (read).

Bits 6 and 7 during a read are a low level, and cannot be written.

EPP ADDRESS PORT**ADDRESS OFFSET = 03H**

The EPP Address Port is located at an offset of '03H' from the base address. The address register is cleared at initialization by RESET. During a WRITE operation, the contents of the internal data bus DB0-DB7 are buffered (non inverting) and output onto the PD0 - PD7 ports. An LPC I/O write cycle causes an EPP ADDRESS WRITE cycle to be performed, during which the data is latched for the duration of the EPP write cycle. During a READ operation, PD0 - PD7 ports are read. An LPC I/O read cycle causes an EPP ADDRESS READ cycle to be performed and the data output to the host CPU, the deassertion of ADDRSTB latches the PData for the duration of the read cycle. This register is only available in EPP mode.

EPP DATA PORT 0**ADDRESS OFFSET = 04H**

The EPP Data Port 0 is located at an offset of '04H' from the base address. The data register is cleared at initialization by RESET. During a WRITE operation, the contents of the internal data bus DB0-DB7 are buffered (non inverting) and output onto the PD0 - PD7 ports. An LPC I/O write cycle causes an EPP DATA WRITE cycle to be performed, during which the data is latched for the duration of the EPP write cycle. During a READ operation, PD0 - PD7 ports are read. An LPC I/O read cycle causes an EPP READ cycle to be performed and the data output to the host CPU, the deassertion of DATASTB latches the PData for the duration of the read cycle. This register is only available in EPP mode.

EPP DATA PORT 1**ADDRESS OFFSET = 05H**

The EPP Data Port 1 is located at an offset of '05H' from the base address. Refer to EPP DATA PORT 0 for a description of operation. This register is only available in EPP mode.

EPP DATA PORT 2**ADDRESS OFFSET = 06H**

The EPP Data Port 2 is located at an offset of '06H' from the base address. Refer to EPP DATA PORT 0 for a description of operation. This register is only available in EPP mode.

EPP DATA PORT 3**ADDRESS OFFSET = 07H**

The EPP Data Port 3 is located at an offset of '07H' from the base address. Refer to EPP DATA PORT 0 for a description of operation. This register is only available in EPP mode.

EPP 1.9 OPERATION

When the EPP mode is selected in the configuration register, the standard and bi-directional modes are also available. If no EPP Read, Write or Address cycle is currently executing, then the PDx bus is in the standard or bi-directional mode, and all output signals (STROBE, AUTOFD, INIT) are as set by the SPP Control Port and direction is controlled by PCD of the Control port.

In EPP mode, the system timing is closely coupled to the EPP timing. For this reason, a watchdog timer is required to prevent system lockup. The timer indicates if more than 10usec have elapsed from

Datasheet

the start of the EPP cycle to nWAIT being deasserted (after command). If a time-out occurs, the current EPP cycle is aborted and the time-out condition is indicated in Status bit 0.

During an EPP cycle, if STROBE is active, it overrides the EPP write signal forcing the PDx bus to always be in a write mode and the nWRITE signal to always be asserted.

SOFTWARE CONSTRAINTS

Before an EPP cycle is executed, the software must ensure that the control register bit PCD is a logic "0" (i.e., a 04H or 05H should be written to the Control port). If the user leaves PCD as a logic "1", and attempts to perform an EPP write, the chip is unable to perform the write (because PCD is a logic "1") and will appear to perform an EPP read on the parallel bus, no error is indicated.

EPP 1.9 WRITE

The timing for a write operation (address or data) is shown in timing diagram EPP Write Data or Address cycle. The chip inserts wait states into the LPC I/O write cycle until it has been determined that the write cycle can complete. The write cycle can complete under the following circumstances:

- If the EPP bus is not ready (nWAIT is active low) when nDATASTB or nADDRSTB goes active then the write can complete when nWAIT goes inactive high.
- If the EPP bus is ready (nWAIT is inactive high) then the chip must wait for it to go active low before changing the state of nDATASTB, nWRITE or nADDRSTB. The write can complete once nWAIT is determined inactive.

Write Sequence of operation

1. The host initiates an I/O write cycle to the selected EPP register.
2. If WAIT is not asserted, the chip must wait until WAIT is asserted.
3. The chip places address or data on PData bus, clears PDIR, and asserts nWRITE.
4. Chip asserts nDATASTB or nADDRSTRB indicating that PData bus contains valid information, and the WRITE signal is valid.
5. Peripheral deasserts nWAIT, indicating that any setup requirements have been satisfied and the chip may begin the termination phase of the cycle.
- 6.
- a. The chip deasserts nDATASTB or nADDRSTRB, this marks the beginning of the termination phase. If it has not already done so, the peripheral should latch the information byte now.
- b. The chip latches the data from the internal data bus for the PData bus and drives the sync that indicates that no more wait states are required followed by the TAR to complete the write cycle.
7. Peripheral asserts nWAIT, indicating to the host that any hold time requirements have been satisfied and acknowledging the termination of the cycle.
8. Chip may modify nWRITE and nPDATA in preparation for the next cycle.

EPP 1.9 READ

The timing for a read operation (data) is shown in timing diagram EPP Read Data cycle. The chip inserts wait states into the LPC I/O read cycle until it has been determined that the read cycle can complete. The read cycle can complete under the following circumstances:

- If the EPP bus is not ready (nWAIT is active low) when nDATASTB goes active then the read can complete when nWAIT goes inactive high.
- If the EPP bus is ready (nWAIT is inactive high) then the chip must wait for it to go active low before changing the state of nWRITE or before nDATASTB goes active. The read can complete once nWAIT is determined inactive.

Read Sequence of Operation

1. The host initiates an I/O read cycle to the selected EPP register.
2. If WAIT is not asserted, the chip must wait until WAIT is asserted.

3. The chip tri-states the PData bus and deasserts nWRITE.
4. Chip asserts nDATASTB or nADDRSTRB indicating that PData bus is tri-stated, PDIR is set and the nWRITE signal is valid.
5. Peripheral drives PData bus valid.
6. Peripheral deasserts nWAIT, indicating that PData is valid and the chip may begin the termination phase of the cycle.
7.
 - a. The chip latches the data from the PData bus for the internal data bus and deasserts nDATASTB or nADDRSTRB. This marks the beginning of the termination phase.
 - b. The chip drives the sync that indicates that no more wait states are required and drives valid data onto the LAD[3:0] signals, followed by the TAR to complete the read cycle.
8. Peripheral tri-states the PData bus and asserts nWAIT, indicating to the host that the PData bus is tri-stated.
9. Chip may modify nWRITE, PDIR and nPDATA in preparation for the next cycle.

EPP 1.7 OPERATION

When the EPP 1.7 mode is selected in the configuration register, the standard and bi-directional modes are also available. If no EPP Read, Write or Address cycle is currently executing, then the PDx bus is in the standard or bi-directional mode, and all output signals (STROBE, AUTOFD, INIT) are as set by the SPP Control Port and direction is controlled by PCD of the Control port.

In EPP mode, the system timing is closely coupled to the EPP timing. For this reason, a watchdog timer is required to prevent system lockup. The timer indicates if more than 10usec have elapsed from the start of the EPP cycle to the end of the cycle. If a time-out occurs, the current EPP cycle is aborted and the time-out condition is indicated in Status bit 0.

SOFTWARE CONSTRAINTS

Before an EPP cycle is executed, the software must ensure that the control register bits D0, D1 and D3 are set to zero. Also, bit D5 (PCD) is a logic "0" for an EPP write or a logic "1" for an EPP read.

EPP 1.7 WRITE

The timing for a write operation (address or data) is shown in timing diagram EPP 1.7 Write Data or Address cycle. The chip inserts wait states into the I/O write cycle when nWAIT is active low during the EPP cycle. This can be used to extend the cycle time. The write cycle can complete when nWAIT is inactive high.

Write Sequence of Operation

- The host sets PDIR bit in the control register to a logic "0". This asserts nWRITE.
- The host initiates an I/O write cycle to the selected EPP register.
- The chip places address or data on PData bus.
- Chip asserts nDATASTB or nADDRSTRB indicating that PData bus contains valid information, and the WRITE signal is valid.
- If nWAIT is asserted, the chip inserts wait states into I/O write cycle until the peripheral deasserts nWAIT or a time-out occurs.
- The chip drives the final sync, deasserts nDATASTB or nADDRSTRB and latches the data from the internal data bus for the PData bus.
- Chip may modify nWRITE, PDIR and nPDATA in preparation of the next cycle.

EPP 1.7 READ

The timing for a read operation (data) is shown in timing diagram EPP 1.7 Read Data cycle. The chip inserts wait states into the I/O read cycle when nWAIT is active low during the EPP cycle. This can be used to extend the cycle time. The read cycle can complete when nWAIT is inactive high.

Datasheet**Read Sequence of Operation**

- The host sets PDIR bit in the control register to a logic “1”. This deasserts nWRITE and tri-states the PData bus.
- The host initiates an I/O read cycle to the selected EPP register.
- Chip asserts nDATASTB or nADDRSTRB indicating that PData bus is tri-stated, PDIR is set and the nWRITE signal is valid.
- If nWAIT is asserted, the chip inserts wait states into the I/O read cycle until the peripheral deasserts nWAIT or a time-out occurs.
- The Peripheral drives PData bus valid.
- The Peripheral deasserts nWAIT, indicating that PData is valid and the chip may begin the termination phase of the cycle.
- The chip drives the final sync and deasserts nDATASTB or nADDRSTRB.
- Peripheral tri-states the PData bus.
- Chip may modify nWRITE, PDIR and nPDATA in preparation of the next cycle.

Table 9.2 EPP Pin Descriptions

EPP SIGNAL	EPP NAME	TYPE	EPP DESCRIPTION
nWRITE	nWrite	O	This signal is active low. It denotes a write operation.
PD<0:7>	Address/Data	I/O	Bi-directional EPP byte wide address and data bus.
INTR	Interrupt	I	This signal is active high and positive edge triggered. (Pass through with no inversion, Same as SPP).
nWAIT	nWait	I	This signal is active low. It is driven inactive as a positive acknowledgement from the device that the transfer of data is completed. It is driven active as an indication that the device is ready for the next transfer.
nDATASTB	nData Strobe	O	This signal is active low. It is used to denote data read or write operation.
nRESET	nReset	O	This signal is active low. When driven active, the EPP device is reset to its initial operational mode.
nADDRSTB	Address Strobe	O	This signal is active low. It is used to denote address read or write operation.
PE	Paper End	I	Same as SPP mode.
SLCT	Printer Selected Status	I	Same as SPP mode.
nERR	Error	I	Same as SPP mode.
Notes:			
1. SPP and EPP can use 1 common register.			
2. nWrite is the only EPP output that can be over-riden by SPP control port during an EPP cycle. For correct EPP read cycles, PCD is required to be a low.			

9.2 Extended Capabilities Parallel Port

ECP provides a number of advantages, some of which are listed below. The individual features are explained in greater detail in the remainder of this section.

High performance half-duplex forward and reverse channel Interlocked handshake, for fast reliable transfer
 Optional single byte RLE compression for improved throughput (64:1)
 Channel addressing for low-cost peripherals
 Maintains link and data layer separation
 Permits the use of active output drivers
 permits the use of adaptive signal timing
 Peer-to-peer capability.

VOCABULARY

The following terms are used in this document:

- assert: When a signal asserts it transitions to a "true" state, when a signal deasserts it transitions to a "false" state.
- forward: Host to Peripheral communication.
- reverse: Peripheral to Host communication
- Pword: A port word; equal in size to the width of the LPC interface. For this implementation, PWord is always 8 bits.
- 1 A high level.
- 0 A low level.

These terms may be considered synonymous:

PeriphClk, nAck

HostAck, nAutoFd

PeriphAck, Busy

nPeriphRequest, nFault

nReverseRequest, nInit

nAckReverse, PError

Xflag, Select

ECPMode, nSelectIn

HostClk, nStrobe

Reference Document: *IEEE 1284 Extended Capabilities Port Protocol and ISA Interface Standard*, Rev 1.14, July 14, 1993. This document is available from Microsoft.

The bit map of the Extended Parallel Port registers is:

	D7	D6	D5	D4	D3	D2	D1	D0	NOTE
data	PD7	PD6	PD5	PD4	PD3	PD2	PD1	PD0	
ecpAFifo	Addr/RLE	Address or RLE field							2
dscr	nBusy	nAck	PError	Select	nFault	0	0	0	1
dcr	0	0	Direction	ackIntEn	SelectIn	nInit	autofd	strobe	1
cFifo	Parallel Port Data FIFO								2

Datasheet

	D7	D6	D5	D4	D3	D2	D1	D0	NOTE
ecpDFifo	ECP Data FIFO								2
tFifo	Test FIFO								2
cnfgA	0	0	0	1	0	0	0	0	
cnfgB	compress	intrValue	Parallel Port IRQ			Parallel Port DMA			
ecr	MODE			nErrIntrE n	dmaEn	service Intr	full	empty	

Notes:

1. These registers are available in all modes.
2. All FIFOs use one common 16 byte FIFO.
3. The ECP Parallel Port Config Reg B reflects the IRQ and DMA channel selected by the Configuration Registers.

ECP IMPLEMENTATION STANDARD

This specification describes the standard interface to the Extended Capabilities Port (ECP). All LPC devices supporting ECP must meet the requirements contained in this section or the port will not be supported by Microsoft. For a description of the ECP Protocol, please refer to the *IEEE 1284 Extended Capabilities Port Protocol and ISA Interface Standard, Rev. 1.14*, July 14, 1993. This document is available from Microsoft.

Description

The port is software and hardware compatible with existing parallel ports so that it may be used as a standard LPT port if ECP is not required. The port is designed to be simple and requires a small number of gates to implement. It does not do any "protocol" negotiation, rather it provides an automatic high burst-bandwidth channel that supports DMA for ECP in both the forward and reverse directions.

Small FIFOs are employed in both forward and reverse directions to smooth data flow and improve the maximum bandwidth requirement. The size of the FIFO is 16 bytes deep. The port supports an automatic handshake for the standard parallel port to improve compatibility mode transfer speed.

The port also supports run length encoded (RLE) decompression (required) in hardware. Compression is accomplished by counting identical bytes and transmitting an RLE byte that indicates how many times the next byte is to be repeated. Decompression simply intercepts the RLE byte and repeats the following byte the specified number of times. Hardware support for compression is optional.

Table 9.3 ECP Pin Descriptions

NAME	TYPE	DESCRIPTION
nStrobe	O	During write operations nStrobe registers data or address into the slave on the asserting edge (handshakes with Busy).
PData 7:0	I/O	Contains address or data or RLE data.
nAck	I	Indicates valid data driven by the peripheral when asserted. This signal handshakes with nAutoFd in reverse.
PeriphAck (Busy)	I	This signal deasserts to indicate that the peripheral can accept data. This signal handshakes with nStrobe in the forward direction. In the reverse direction this signal indicates whether the data lines contain ECP command information or data. The peripheral uses this signal to automatic direction control in the forward direction. It is an "interlocked" handshake with nStrobe. PeriphAck also provides command information in the reverse direction.

Table 9.3 ECP Pin Descriptions (continued)

NAME	TYPE	DESCRIPTION
PError (nAckReverse)	I	Used to acknowledge a change in the direction the transfer (asserted = forward). The peripheral drives this signal low to acknowledge nReverseRequest. It is an "interlocked" handshake with nReverseRequest. The host relies upon nAckReverse to determine when it is permitted to drive the data bus.
Select	I	Indicates printer on line.
nAutoFd (HostAck)	O	Requests a byte of data from the peripheral when asserted, handshaking with nAck in the reverse direction. In the forward direction this signal indicates whether the data lines contain ECP address or data. The host drives this signal to automatic direction control in the reverse direction. It is an "interlocked" handshake with nAck. HostAck also provides command information in the forward phase.
nFault (nPeriphRequest)	I	Generates an error interrupt when asserted. This signal provides a mechanism for peer-to-peer communication. This signal is valid only in the forward direction. During ECP Mode the peripheral is permitted (but not required) to drive this pin low to request a reverse transfer. The request is merely a "hint" to the host; the host has ultimate control over the transfer direction. This signal would be typically used to generate an interrupt to the host CPU.
nInit	O	Sets the transfer direction (asserted = reverse, deasserted = forward). This pin is driven low to place the channel in the reverse direction. The peripheral is only allowed to drive the bi-directional data bus while in ECP Mode and HostAck is low and nSelectIn is high.
nSelectIn	O	Always deasserted in ECP mode.

REGISTER DEFINITIONS

The register definitions are based on the standard IBM addresses for LPT. All of the standard printer ports are supported. The additional registers attach to an upper bit decode of the standard LPT port definition to avoid conflict with standard ISA devices. The port is equivalent to a generic parallel port interface and may be operated in that mode. The port registers vary depending on the mode field in the ecr. [Table 9.4](#) lists these dependencies. Operation of the devices in modes other than those specified is undefined.

Table 9.4 ECP Register Definitions

NAME	ADDRESS (NOTE 1)	ECP MODES	FUNCTION
data	+000h R/W	000-001	Data Register
ecpAFifo	+000h R/W	011	ECP FIFO (Address)
dsr	+001h R/W	All	Status Register
dcr	+002h R/W	All	Control Register
cFifo	+400h R/W	010	Parallel Port Data FIFO
ecpDFifo	+400h R/W	011	ECP FIFO (DATA)
tFifo	+400h R/W	110	Test FIFO
cnfgA	+400h R	111	Configuration Register A
cnfgB	+401h R/W	111	Configuration Register B
ecr	+402h R/W	All	Extended Control Register
Notes:			
1. These addresses are added to the parallel port base address as selected by configuration register or jumpers.			
2. All addresses are qualified with AEN. Refer to the AEN pin definition.			

Table 9.5 Mode Descriptions

MODE	DESCRIPTION*
000	SPP mode
001	PS/2 Parallel Port mode
010	Parallel Port Data FIFO mode
011	ECP Parallel Port mode
100	EPP mode (If this option is enabled in the configuration registers)
101	Reserved
110	Test mode
111	Configuration mode
*Refer to ECR Register Description	

DATA AND ECPAFIFO PORT**ADDRESS OFFSET = 00H**

Modes 000 and 001 (Data Port)

The Data Port is located at an offset of '00H' from the base address. The data register is cleared at initialization by RESET. During a WRITE operation, the Data Register latches the contents of the data bus. The contents of this register are buffered (non inverting) and output onto the PD0 - PD7 ports. During a READ operation, PD0 - PD7 ports are read and output to the host CPU.

Mode 011 (ECP FIFO - Address/RLE)

A data byte written to this address is placed in the FIFO and tagged as an ECP Address/RLE. The hardware at the ECP port transmits this byte to the peripheral automatically. The operation of this register is only defined for the forward direction (direction is 0). Refer to PME_STS1, located in PME_STS1 of this data sheet.

DEVICE STATUS REGISTER (DSR)**ADDRESS OFFSET = 01H**

The Status Port is located at an offset of '01H' from the base address. Bits0 - 2 are not implemented as register bits, during a read of the Printer Status Register these bits are a low level. The bits of the Status Port are defined as follows:

Bit 3 nFault

The level on the nFault input is read by the CPU as bit 3 of the Device Status Register.

Bit 4 Select

The level on the Select input is read by the CPU as bit 4 of the Device Status Register.

Bit 5 PError

The level on the PError input is read by the CPU as bit 5 of the Device Status Register. Printer Status Register.

Bit 6 nAck

The level on the nAck input is read by the CPU as bit 6 of the Device Status Register.

Bit 7 nBusy

The complement of the level on the BUSY input is read by the CPU as bit 7 of the Device Status Register.

DEVICE CONTROL REGISTER (DCR)**ADDRESS OFFSET = 02H**

The Control Register is located at an offset of '02H' from the base address. The Control Register is initialized to zero by the RESET input, bits 0 to 5 only being affected; bits 6 and 7 are hard wired low.

Bit 0 STROBE - STROBE

This bit is inverted and output onto the nSTROBE output.

Bit 1 AUTOFD - AUTOFEED

This bit is inverted and output onto the nAutoFd output. A logic 1 causes the printer to generate a line feed after each line is printed. A logic 0 means no autofeed.

Bit 2 nINIT - INITIATE OUTPUT

This bit is output onto the nINIT output without inversion.

Bit 3 SELECTIN

This bit is inverted and output onto the nSLCTIN output. A logic 1 on this bit selects the printer; a logic 0 means the printer is not selected.

Bit 4 ackIntEn - INTERRUPT REQUEST ENABLE

The interrupt request enable bit when set to a high level may be used to enable interrupt requests from the Parallel Port to the CPU due to a low to high transition on the nACK input. Refer to the description of the interrupt under Operation, Interrupts.

Datasheet**Bit 5 DIRECTION**

If mode=000 or mode=010, this bit has no effect and the direction is always out regardless of the state of this bit. In all other modes, Direction is valid and a logic 0 means that the printer port is in output mode (write); a logic 1 means that the printer port is in input mode (read).

Bits 6 and 7 during a read are a low level, and cannot be written.

cFifo (Parallel Port Data FIFO)

ADDRESS OFFSET = 400h

Mode = 010

Bytes written or DMAed from the system to this FIFO are transmitted by a hardware handshake to the peripheral using the standard parallel port protocol. Transfers to the FIFO are byte aligned. This mode is only defined for the forward direction.

ecpDFifo (ECP Data FIFO)

ADDRESS OFFSET = 400H

Mode = 011

Bytes written or DMAed from the system to this FIFO, when the direction bit is 0, are transmitted by a hardware handshake to the peripheral using the ECP parallel port protocol. Transfers to the FIFO are byte aligned.

Data bytes from the peripheral are read under automatic hardware handshake from ECP into this FIFO when the direction bit is 1. Reads or DMAs from the FIFO will return bytes of ECP data to the system.

tFifo (Test FIFO Mode)

ADDRESS OFFSET = 400H

Mode = 110

Data bytes may be read, written or DMAed to or from the system to this FIFO in any direction. Data in the tFIFO will not be transmitted to the parallel port lines using a hardware protocol handshake. However, data in the tFIFO may be displayed on the parallel port data lines.

The tFIFO will not stall when overwritten or underrun. If an attempt is made to write data to a full tFIFO, the new data is not accepted into the tFIFO. If an attempt is made to read data from an empty tFIFO, the last data byte is re-read again. The full and empty bits must always keep track of the correct FIFO state. The tFIFO will transfer data at the maximum ISA rate so that software may generate performance metrics.

The FIFO size and interrupt threshold can be determined by writing bytes to the FIFO and checking the full and serviceIntr bits.

The writeIntrThreshold can be determined by starting with a full tFIFO, setting the direction bit to 0 and emptying it a byte at a time until serviceIntr is set. This may generate a spurious interrupt, but will indicate that the threshold has been reached.

The readIntrThreshold can be determined by setting the direction bit to 1 and filling the empty tFIFO a byte at a time until serviceIntr is set. This may generate a spurious interrupt, but will indicate that the threshold has been reached.

Data bytes are always read from the head of tFIFO regardless of the value of the direction bit. For example if 44h, 33h, 22h is written to the FIFO, then reading the tFIFO will return 44h, 33h, 22h in the same order as was written.

cnfgA (Configuration Register A)

ADDRESS OFFSET = 400H

Mode = 111

This register is a read only register. When read, 10H is returned. This indicates to the system that this is an 8-bit implementation. (PWord = 1 byte)

cnfgB (Configuration Register B)

ADDRESS OFFSET = 401H

Mode = 111

Bit 7 compress

This bit is read only. During a read it is a low level. This means that this chip does not support hardware RLE compression. It does support hardware de-compression.

Bit 6 intrValue

Returns the value of the interrupt to determine possible conflicts.

Bit [5:3] Parallel Port IRQ (read-only)

to [Table 9.7 on page 116](#).

Bits [2:0] Parallel Port DMA (read-only)

to [Table 9.8 on page 116](#).

ecr (Extended Control Register)

ADDRESS OFFSET = 402H

Mode = all

This register controls the extended ECP parallel port functions.

Bits 7,6,5

These bits are Read/Write and select the Mode.

Bit 4 nErrIntrEn

Read/Write (Valid only in ECP Mode)

1: Disables the interrupt generated on the asserting edge of nFault.

0: Enables an interrupt pulse on the high to low edge of nFault. Note that an interrupt will be generated if nFault is asserted (interrupting) and this bit is written from a 1 to a 0. This prevents interrupts from being lost in the time between the read of the ecr and the write of the ecr.

Bit 3 dmaEn

Read/Write

1: Enables DMA (DMA starts when serviceIntr is 0).

0: Disables DMA unconditionally.

Bit 2 serviceIntr

Read/Write

1: Disables DMA and all of the service interrupts.

Datasheet

0: Enables one of the following 3 cases of interrupts. Once one of the 3 service interrupts has occurred serviceIntr bit shall be set to a 1 by hardware. It must be reset to 0 to re-enable the interrupts. Writing this bit to a 1 will not cause an interrupt.

case dmaEn=1:

During DMA (this bit is set to a 1 when terminal count is reached).

case dmaEn=0 direction=0:

This bit shall be set to 1 whenever there are writeIntrThreshold or more bytes free in the FIFO.

case dmaEn=0 direction=1:

This bit shall be set to 1 whenever there are readIntrThreshold or more valid bytes to be read from the FIFO.

Bit 1 full

Read only

1: The FIFO cannot accept another byte or the FIFO is completely full.

0: The FIFO has at least 1 free byte.

Bit 0 empty

Read only

1: The FIFO is completely empty.

0: The FIFO contains at least 1 byte of data.

Table 9.6 Extended Control Register (a)

R/W	MODE
000:	Standard Parallel Port Mode. In this mode the FIFO is reset and common drain drivers are used on the control lines (nStrobe, nAutoFd, nIntr and nSelectIn). Setting the direction bit will not tri-state the output drivers in this mode.
001:	PS/2 Parallel Port Mode. Same as above except that direction may be used to tri-state the data lines and reading the data register returns the value on the data lines and not the value in the data register. All drivers have active pull-ups (push-pull).
010:	Parallel Port FIFO Mode. This is the same as 000 except that bytes are written or DMAed to the FIFO. FIFO data is automatically transmitted using the standard parallel port protocol. Note that this mode is only useful when direction is 0. All drivers have active pull-ups (push-pull).
011:	ECP Parallel Port Mode. In the forward direction (direction is 0) bytes placed into the ecpDFifo and bytes written to the ecpAFifo are placed in a single FIFO and transmitted automatically to the peripheral using ECP Protocol. In the reverse direction (direction is 1) bytes are moved from the ECP parallel port and packed into bytes in the ecpDFifo. All drivers have active pull-ups (push-pull).
100:	Selects EPP Mode: In this mode, EPP is selected if the EPP supported option is selected in configuration register L3-CRF0. All drivers have active pull-ups (push-pull).
101:	Reserved
110:	Test Mode. In this mode the FIFO may be written and read, but the data will not be transmitted on the parallel port. All drivers have active pull-ups (push-pull).
111:	Configuration Mode. In this mode the configA, configB registers are accessible at 0x400 and 0x401. All drivers have active pull-ups (push-pull).

Table 9.7 Extended Control Register (b)

IRQ SELECTED	CONFIG REG B BITS 5:3
15	110
14	101
11	100
10	011
9	010
7	001
5	111
All others	000

Table 9.8 Extended Control Register (c)

IRQ SELECTED	CONFIG REG B BITS 5:3
3	011
2	010
1	001
All others	000

OPERATION

Mode Switching/Software Control

Software will execute P1284 negotiation and all operation prior to a data transfer phase under programmed I/O control (mode 000 or 001). Hardware provides an automatic control line handshake, moving data between the FIFO and the ECP port only in the data transfer phase (modes 011 or 010).

Setting the mode to 011 or 010 will cause the hardware to initiate data transfer.

If the port is in mode 000 or 001 it may switch to any other mode. If the port is not in mode 000 or 001 it can only be switched into mode 000 or 001. The direction can only be changed in mode 001.

Once in an extended forward mode the software should wait for the FIFO to be empty before switching back to mode 000 or 001. In this case all control signals will be deasserted before the mode switch. In an ecp reverse mode the software waits for all the data to be read from the FIFO before changing back to mode 000 or 001. Since the automatic hardware ecp reverse handshake only cares about the state of the FIFO it may have acquired extra data which will be discarded. It may in fact be in the middle of a transfer when the mode is changed back to 000 or 001. In this case the port will deassert nAutoFd independent of the state of the transfer. The design shall not cause glitches on the handshake signals if the software meets the constraints above.

Datasheet**ECP OPERATION**

Prior to ECP operation the Host must negotiate on the parallel port to determine if the peripheral supports the ECP protocol. This is a somewhat complex negotiation carried out under program control in mode 000.

After negotiation, it is necessary to initialize some of the port bits. The following are required:

Set `Direction = 0`, enabling the drivers.

Set `strobe = 0`, causing the `nStrobe` signal to default to the deasserted state.

Set `autoFd = 0`, causing the `nAutoFd` signal to default to the deasserted state.

Set `mode = 011` (ECP Mode)

ECP address/RLE bytes or data bytes may be sent automatically by writing the `ecpAFifo` or `ecpDFifo` respectively.

Note that all FIFO data transfers are byte wide and byte aligned. Address/RLE transfers are byte-wide and only allowed in the forward direction.

The host may switch directions by first switching to mode = 001, negotiating for the forward or reverse channel, setting direction to 1 or 0, then setting mode = 011. When direction is 1 the hardware shall handshake for each ECP read data byte and attempt to fill the FIFO. Bytes may then be read from the `ecpDFifo` as long as it is not empty.

ECP transfers may also be accomplished (albeit slowly) by handshaking individual bytes under program control in mode = 001, or 000.

TERMINATION FROM ECP MODE

Termination from ECP Mode is similar to the termination from Nibble/Byte Modes. The host is permitted to terminate from ECP Mode only in specific well-defined states. The termination can only be executed while the bus is in the forward direction. To terminate while the channel is in the reverse direction, it must first be transitioned into the forward direction.

COMMAND/DATA

ECP Mode supports two advanced features to improve the effectiveness of the protocol for some applications. The features are implemented by allowing the transfer of normal 8 bit data or 8 bit commands.

When in the forward direction, normal data is transferred when `HostAck` is high and an 8 bit command is transferred when `HostAck` is low.

The most significant bit of the command indicates whether it is a run-length count (for compression) or a channel address.

When in the reverse direction, normal data is transferred when `PeriphAck` is high and an 8 bit command is transferred when `PeriphAck` is low. The most significant bit of the command is always zero. Reverse channel addresses are seldom used and may not be supported in hardware.

Table 9.9 Channel/Data Commands Supported in ECP Mode

Forward Channel Commands (HostAck Low) Reverse Channel Commands (PeriphAck Low)	
D7	D[6:0]
0	Run-Length Count (0-127) (mode 0011 0X00 only)
1	Channel Address (0-127)

DATA COMPRESSION

The ECP port supports run length encoded (RLE) decompression in hardware and can transfer compressed data to a peripheral. Run length encoded (RLE) compression in hardware is not supported. To transfer compressed data in ECP mode, the compression count is written to the `ecpAFifo` and the data byte is written to the `ecpDFifo`.

Compression is accomplished by counting identical bytes and transmitting an RLE byte that indicates how many times the next byte is to be repeated. Decompression simply intercepts the RLE byte and repeats the following byte the specified number of times. When a run-length count is received from a peripheral, the subsequent data byte is replicated the specified number of times. A run-length count of zero specifies that only one byte of data is represented by the next data byte, whereas a run-length count of 127 indicates that the next byte should be expanded to 128 bytes. To prevent data expansion, however, run-length counts of zero should be avoided.

PIN DEFINITION

The drivers for `nStrobe`, `nAutoFd`, `nIntr` and `nSelectIn` are open-drain in mode 000 and are push-pull in all other modes.

LPC CONNECTIONS

The interface can never stall causing the host to hang. The width of data transfers is strictly controlled on an I/O address basis per this specification. All FIFO-DMA transfers are byte wide, byte aligned and end on a byte boundary. (The `PWord` value can be obtained by reading Configuration Register A, `cnfgA`, described in the next section). Single byte wide transfers are always possible with standard or PS/2 mode using program control of the control signals.

INTERRUPTS

The interrupts are enabled by `serviceIntr` in the `ecr` register.

`serviceIntr = 1` Disables the DMA and all of the service interrupts.

`serviceIntr = 0` Enables the selected interrupt condition. If the interrupting condition is valid, then the interrupts generated immediately when this bit is changed from a 1 to a 0. This can occur during Programmed I/O if the number of bytes removed or added from/to the FIFO does not cross the threshold.

An interrupt is generated when:

1. For DMA transfers: When `serviceIntr` is 0, `dmaEn` is 1 and the DMA TC cycle is received.
2. For Programmed I/O:
 - a. When `serviceIntr` is 0, `dmaEn` is 0, `direction` is 0 and there are `writeIntrThreshold` or more free bytes in the FIFO. Also, an interrupt is generated when `serviceIntr` is cleared to 0 whenever there are `writeIntrThreshold` or more free bytes in the FIFO.
 - b. When `serviceIntr` is 0, `dmaEn` is 0, `direction` is 1 and there are `readIntrThreshold` or more bytes in the FIFO. Also, an interrupt is generated when `serviceIntr` is cleared to 0 whenever there are `readIntrThreshold` or more bytes in the FIFO.
3. When `nErrIntrEn` is 0 and `nFault` transitions from high to low or when `nErrIntrEn` is set from 1 to 0 and `nFault` is asserted.
4. When `ackIntrEn` is 1 and the `nAck` signal transitions from a low to a high.

FIFO OPERATION

The FIFO threshold is set in the chip configuration registers. All data transfers to or from the parallel port can proceed in DMA or Programmed I/O (non-DMA) mode as indicated by the selected mode. The FIFO is used by selecting the Parallel Port FIFO mode or ECP Parallel Port Mode. (FIFO test mode will be addressed separately.) After a reset, the FIFO is disabled. Each data byte is transferred by a Programmed I/O cycle or DMA cycle depending on the selection of DMA or Programmed I/O mode.

Datasheet

The following paragraphs detail the operation of the FIFO automatic direction control. In these descriptions, <threshold> ranges from 1 to 16. The parameter FIFOTHR, which the user programs, is one less and ranges from 0 to 15.

A low threshold value (i.e. 2) results in longer periods of time between service requests, but requires faster servicing of the request for both read and write cases. The host must be very responsive to the service request. This is the desired case for use with a “fast” system. A high value of threshold (i.e. 12) is used with a “sluggish” system by affording a long latency period after a service request, but results in more frequent service requests.

DMA TRANSFERS

DMA transfers are always to or from the ecpDFifo, tFifo or CFifo. DMA utilizes the standard PC DMA services. To use the DMA transfers, the host first sets up the direction and state as in the programmed I/O case. Then it programs the DMA controller in the host with the desired count and memory address. Lastly it sets dmaEn to 1 and serviceIntr to 0. The ECP requests DMA transfers from the host by encoding the LDRQ# pin. The DMA will empty or fill the FIFO using the appropriate direction and mode. When the terminal count in the DMA controller is reached, an interrupt is generated and serviceIntr is asserted, disabling DMA. In order to prevent possible blocking of refresh requests a DMA cycle shall not be requested for more than 32 DMA cycles in a row. The FIFO is enabled directly by the host initiating a DMA cycle for the requested channel, and addresses need not be valid. An interrupt is generated when a TC cycle is received. (Note: The only way to properly terminate DMA transfers is with a TC cycle.)

DMA may be disabled in the middle of a transfer by first disabling the host DMA controller. Then setting serviceIntr to 1, followed by setting dmaEn to 0, and waiting for the FIFO to become empty or full. Restarting the DMA is accomplished by enabling DMA in the host, setting dmaEn to 1, followed by setting serviceIntr to 0.

DMA MODE - TRANSFERS FROM THE FIFO TO THE HOST

Note: In the reverse mode, the peripheral may not continue to fill the FIFO if it runs out of data to transfer, even if the chip continues to request more data from the peripheral.)

The ECP requests a DMA cycle whenever there is data in the FIFO. The DMA controller must respond to the request by reading data from the FIFO. The ECP stops requesting DMA cycles when the FIFO becomes empty or when a TC cycle is received, indicating that no more data is required. If the ECP stops requesting DMA cycles due to the FIFO going empty, then a DMA cycle is requested again as soon as there is one byte in the FIFO. If the ECP stops requesting DMA cycles due to the TC cycle, then a DMA cycle is requested again when there is one byte in the FIFO, and serviceIntr has been re-enabled.

PROGRAMMED I/O MODE OR NON-DMA MODE

The ECP or parallel port FIFOs may also be operated using interrupt driven programmed I/O. Software can determine the writeIntrThreshold, readIntrThreshold, and FIFO depth by accessing the FIFO in Test Mode.

Programmed I/O transfers are to the ecpDFifo at 400H and ecpAFifo at 000H or from the ecpDFifo located at 400H, or to/from the tFifo at 400H. To use the programmed I/O transfers, the host first sets up the direction and state, sets dmaEn to 0 and serviceIntr to 0.

The ECP requests programmed I/O transfers from the host by activating the interrupt. The programmed I/O will empty or fill the FIFO using the appropriate direction and mode.

Note: A threshold of 16 is equivalent to a threshold of 15. These two cases are treated the same.

PROGRAMMED I/O - TRANSFERS FROM THE FIFO TO THE HOST

In the reverse direction an interrupt occurs when serviceIntr is 0 and readIntrThreshold bytes are available in the FIFO. If at this time the FIFO is full it can be emptied completely in a single burst, otherwise readIntrThreshold bytes may be read from the FIFO in a single burst.

readIntrThreshold = (16-<threshold>) data bytes in FIFO

An interrupt is generated when serviceIntr is 0 and the number of bytes in the FIFO is greater than or equal to (16-<threshold>). (If the threshold = 12, then the interrupt is set whenever there are 4-16 bytes in the FIFO). The host must respond to the request by reading data from the FIFO. This process is repeated until the last byte is transferred out of the FIFO. If at this time the FIFO is full, it can be completely emptied in a single burst, otherwise a minimum of (16-<threshold>) bytes may be read from the FIFO in a single burst.

PROGRAMMED I/O - TRANSFERS FROM THE HOST TO THE FIFO

In the forward direction an interrupt occurs when serviceIntr is 0 and there are writeIntrThreshold or more bytes free in the FIFO. At this time if the FIFO is empty it can be filled with a single burst before the empty bit needs to be re-read. Otherwise it may be filled with writeIntrThreshold bytes.

writeIntrThreshold = (16-<threshold>) free bytes in FIFO

An interrupt is generated when serviceIntr is 0 and the number of bytes in the FIFO is less than or equal to <threshold>. (If the threshold = 12, then the interrupt is set whenever there are 12 or less bytes of data in the FIFO.) The host must respond to the request by writing data to the FIFO. If at this time the FIFO is empty, it can be completely filled in a single burst, otherwise a minimum of (16-<threshold>) bytes may be written to the FIFO in a single burst. This process is repeated until the last byte is transferred into the FIFO.

9.3 Parallel Port Floppy Disk Controller

The Floppy Disk Control signals are available optionally on the parallel port pins. When this mode is selected, the parallel port is not available. There are two modes of operation, PPF1 and PPF2. These modes can be selected in the FDC on PP Register, as defined in Logical Device 0xA, at 0xF1. PPF1 has only drive 1 on the parallel port pins; PPF2 has drive 0 and 1 on the parallel port pins.

The FDC pins associated with the parallel port pins are summarized in [Table 9.10](#). There are 3 possible modes of operation:

- Normal mode (default) - Drive 0 is on the fdc pins, the parallel port acts as a parallel port
- Mode 1 - Drive 0 is on the fdc pins, Drive 1 is on the PP pins
- Mode 2 - Drive 0/1 are on the PP pins.

Table 9.10 Parallel Port Floppy Pin Out

CONNECTOR PIN #	PARALLEL PORT SPP MODE		FDC MODE 1		FDC MODE 2	
	SIGNAL NAME	PIN DIRECTION	SIGNAL NAME	PIN DIRECTION	SIGNAL NAME	PIN DIRECTION
1	nSTROBE	I/O	-	Tristate	nDS0	O
2	PD0	I/O	nINDEX	I	nINDEX	I
3	PD1	I/O	nTRK0	I	nTRK0	I
4	PD2	I/O	nWP	I	nWP	I
5	PD3	I/O	nRDATA	I	nRDATA	I
6	PD4	I/O	nDSKCHG	I	nDSKCHG	I
7	PD5	I/O	-	-	-	-
8	PD6	I/O	-	Tristate	nMTR0	O
9	PD7	I/O	-	-	-	-

Table 9.10 Parallel Port Floppy Pin Out (continued)

CONNECTOR PIN #	PARALLEL PORT SPP MODE		FDC MODE 1		FDC MODE 2	
	SIGNAL NAME	PIN DIRECTION	SIGNAL NAME	PIN DIRECTION	SIGNAL NAME	PIN DIRECTION
10	NACK	I	nDS1	O	nDS1	O
11	BUSY	I	nMTR1	O	nMTR1	O
12	PE	I	nWDATA	O	nWDATA	O
13	SLCT	I	nWGATE	O	nWGATE	O
14	nALF	I/O	DRV DEN0	O	DRV DEN0	O
15	nERR	I	nHDSEL	O	nHDSEL	O
16	nINIT	I/O	nDIR	O	nDIR	O
17	nSLCTIN	I/O	nSTEP	O	nSTEP	O

9.3.1 Buffer Types

The buffer types of the parallel port pins are summarized in [Table 9.11](#).

Table 9.11 PP Buffer Types

PARALLEL PORT I/F	FDC I/F	PP BUFFER	FDC BUFFER
nINIT	nDIR	(OD14/OP14)	OD14
nSLCTIN	nSTEP	(OD14/OP14)	OD14
PD0	nINDEX	IOP14	I
PD1	nTRK0	IOP14	I
PD2	nWP	IOP14	I
PD3	nRDATA	IOP14	I
PD4	nDSKCHG	IOP14	I
PD5	-	IOP14	-
PD6	nMTR0	IOP14	I
PD7	-	IOP14	-
SLCT	nWGATE	I	OD12
PE	nWDATA	I	OD12
BUSY	nMTR1	I	nMTR1
nACK	nDS1	I	nDS1
nERROR	nHDSEL	I	OD12
nALF	DRV DEN0	(OD14/OP14)	OD14
nSTROBE	nDS0	(OD14/OP14)	OD14

9.3.2 FDC/PP Control Bits

Parallel Port FDC control bits are in the FDC on PP register (Configuration Register 0xF1 in logical device 0xA). Refer to [Table 25.15 on page 288](#) for more details.

Chapter 10 Power Management

Power management capabilities are provided for the following logical devices: floppy disk, UART 1, UART 2 and the parallel port.

Note: Each Logical Device may be place in powerdown mode by clearing the associated activate bit located at CR30 or by clearing the associated power bit located in the Power Control register at CR22.

FDC Power Management

Direct power management is controlled by CR22. Refer to CR22 for more information.

FDD Interface Pins

All pins in the FDD interface which can be connected directly to the floppy disk drive itself are either DISABLED or TRISTATED.

Table 10.1, "State of Floppy Disk Drive Interface Pins in Powerdown" depicts the state of the floppy disk drive interface pins in the powerdown state.

Table 10.1 State of Floppy Disk Drive Interface Pins in Powerdown

FDD PINS	STATE IN POWERDOWN
INPUT PINS	
nRDATA	Input
nWRTPRT	Input
nTRK0	Input
nINDEX	Input
nDSKCHG	Input
OUTPUT PINS	
nMTR0	Tristated
nDS0	Tristated
nDIR	Tristated
nSTEP	Tristated
nWDATA	Tristated
nWGATE	Tristated
nHDSEL	Tristated
DRV DEN[0:1]	Tristated

UART Power Management

Direct power management is controlled by CR22. Refer to CR22 for more information.

Parallel Port

Direct power management is controlled by CR22. Refer to CR22 for more information.

Chapter 11 Serial IRQ

The SCH311X supports the serial interrupt to transmit interrupt information to the host system. The serial interrupt scheme adheres to the Serial IRQ Specification for PCI Systems, Version 6.0.

TIMING DIAGRAMS FOR SER_IRQ CYCLE

- a. Start Frame timing with source sampled a low pulse on IRQ1

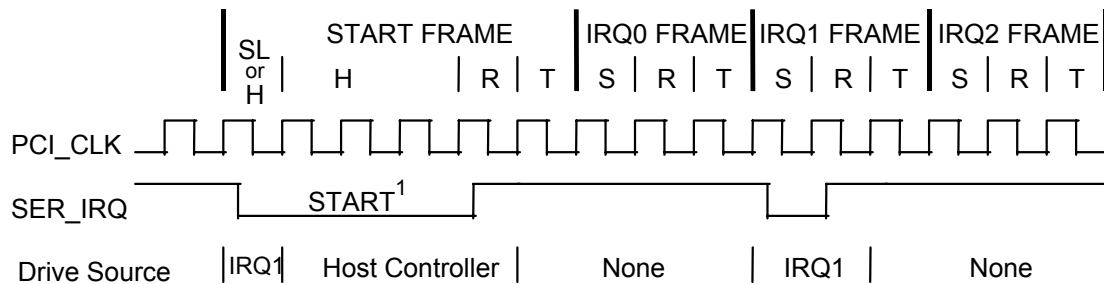

Notes:

- H=Host Control; R=Recovery; T=Turn-Around; SL=Slave Control; S=Sample
 - Start Frame pulse can be 4-8 clocks wide depending on the location of the device in the PCI bridge hierarchy in a synchronous bridge design.
- b. Stop Frame Timing with Host using 17 SER_IRQ sampling period

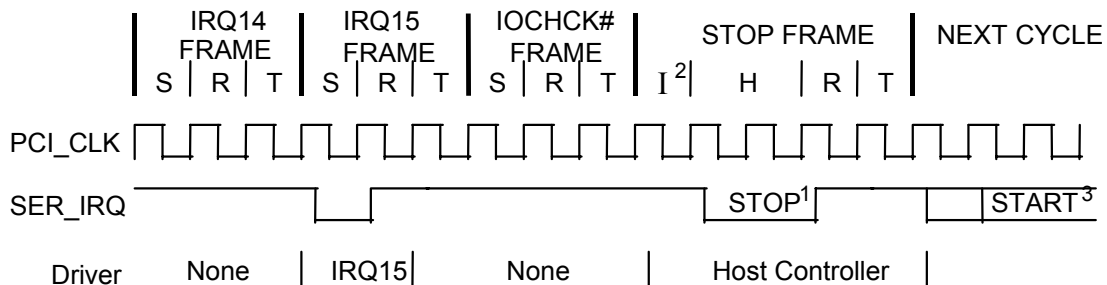

Notes:

- H=Host Control; R=Recovery; T=Turn-Around; S=Sample; I=Idle
- The next SER_IRQ cycle's Start Frame pulse may or may not start immediately after the turn-around clock of the Stop Frame.
- There may be none, one or more Idle states during the Stop Frame.
- Stop pulse is 2 clocks wide for Quiet mode, 3 clocks wide for Continuous mode.

SER_IRQ CYCLE CONTROL

There are two modes of operation for the SER_IRQ Start Frame

- Quiet (Active) Mode:** Any device may initiate a Start Frame by driving the SER_IRQ low for one clock, while the SER_IRQ is Idle. After driving low for one clock the SER_IRQ must immediately be tri-stated without at any time driving high. A Start Frame may not be initiated while the SER_IRQ is Active. The SER_IRQ is Idle between Stop and Start Frames. The SER_IRQ is Active between Start and Stop Frames. This mode of operation allows the SER_IRQ to be Idle when there are no IRQ/Data transitions which should be most of the time.

Once a Start Frame has been initiated the Host Controller will take over driving the SER_IRQ low in the next clock and will continue driving the SER_IRQ low for a programmable period of three to seven clocks. This makes a total low pulse width of four to eight clocks. Finally, the Host Controller will drive the SER_IRQ back high for one clock, then tri-state.

Any SER_IRQ Device (i.e., The SCH311X which detects any transition on an IRQ/Data line for which it is responsible must initiate a Start Frame in order to update the Host Controller unless the SER_IRQ is already in an SER_IRQ Cycle and the IRQ/Data transition can be delivered in that SER_IRQ Cycle

2. **Continuous (Idle) Mode:** Only the Host controller can initiate a Start Frame to update IRQ/Data line information. All other SER_IRQ agents become passive and may not initiate a Start Frame. SER_IRQ will be driven low for four to eight clocks by Host Controller. This mode has two functions. It can be used to stop or idle the SER_IRQ or the Host Controller can operate SER_IRQ in a continuous mode by initiating a Start Frame at the end of every Stop Frame.

An SER_IRQ mode transition can only occur during the Stop Frame. Upon reset, SER_IRQ bus is defaulted to Continuous mode, therefore only the Host controller can initiate the first Start Frame. Slaves must continuously sample the Stop Frames pulse width to determine the next SER_IRQ Cycle's mode.

SER_IRQ DATA FRAME

Once a Start Frame has been initiated, the SCH311X will watch for the rising edge of the Start Pulse and start counting IRQ/Data Frames from there. Each IRQ/Data Frame is three clocks: Sample phase, Recovery phase, and Turn-around phase. During the Sample phase the SCH311X must drive the SER_IRQ low, if and only if, its last detected IRQ/Data value was low. If its detected IRQ/Data value is high, SER_IRQ must be left tri-stated. During the Recovery phase the SCH311X must drive the SER_IRQ high, if and only if, it had driven the SER_IRQ low during the previous Sample Phase. During the Turn-around Phase the SCH311X must tri-state the SER_IRQ. The SCH311X will drive the SER_IRQ line low at the appropriate sample point if its associated IRQ/Data line is low, regardless of which device initiated the Start Frame.

The Sample Phase for each IRQ/Data follows the low to high transition of the Start Frame pulse by a number of clocks equal to the IRQ/Data Frame times three, minus one. (e.g. The IRQ5 Sample clock is the sixth IRQ/Data Frame, $(6 \times 3) - 1 = 17^{\text{th}}$ clock after the rising edge of the Start Pulse).

SER_IRQ SAMPLING PERIODS		
SER_IRQ PERIOD	SIGNAL SAMPLED	# OF CLOCKS PAST START
1	Not Used	2
2	IRQ1	5
3	nIO_SMI/IRQ2	8
4	IRQ3	11
5	IRQ4	14
6	IRQ5	17
7	IRQ6	20
8	IRQ7	23
9	IRQ8	26
10	IRQ9	29
11	IRQ10	32
12	IRQ11	35

Datasheet

SER_IRQ SAMPLING PERIODS		
SER_IRQ PERIOD	SIGNAL SAMPLED	# OF CLOCKS PAST START
13	IRQ12	38
14	IRQ13	41
15	IRQ14	44
16	IRQ15	47

The SER_IRQ data frame supports IRQ2 from a logical device on Period 3, which can be used for the System Management Interrupt (nSMI). When using Period 3 for IRQ2 the user should mask off the SMI via the SMI Enable Register. Likewise, when using Period 3 for nSMI the user should not configure any logical devices as using IRQ2.

SER_IRQ Period 14 is used to transfer IRQ13. Logical devices 0 (FDC), 3 (Par Port), 4 (Ser Port 1), 5 (Ser Port 2), and 7 (KBD) shall have IRQ13 as a choice for their primary interrupt.

The SMI is enabled onto the SMI frame of the Serial IRQ via bit 6 of SMI Enable Register 2 and onto the nIO_SMI pin via bit 7 of the SMI Enable Register 2.

STOP CYCLE CONTROL

Once all IRQ/Data Frames have completed the Host Controller will terminate SER_IRQ activity by initiating a Stop Frame. Only the Host Controller can initiate the Stop Frame. A Stop Frame is indicated when the SER_IRQ is low for two or three clocks. If the Stop Frame's low time is two clocks then the next SER_IRQ Cycle's sampled mode is the Quiet mode; and any SER_IRQ device may initiate a Start Frame in the second clock or more after the rising edge of the Stop Frame's pulse. If the Stop Frame's low time is three clocks then the next SER_IRQ Cycle's sampled mode is the Continuous mode; and only the Host Controller may initiate a Start Frame in the second clock or more after the rising edge of the Stop Frame's pulse.

LATENCY

Latency for IRQ/Data updates over the SER_IRQ bus in bridge-less systems with the minimum Host supported IRQ/Data Frames of seventeen, will range up to 96 clocks (3.84 μ S with a 25MHz PCI Bus or 2.88 μ S with a 33MHz PCI Bus). If one or more PCI to PCI Bridge is added to a system, the latency for IRQ/Data updates from the secondary or tertiary buses will be a few clocks longer for synchronous buses, and approximately double for asynchronous buses.

EOI/ISR READ LATENCY

Any serialized IRQ scheme has a potential implementation issue related to IRQ latency. IRQ latency could cause an EOI or ISR Read to precede an IRQ transition that it should have followed. This could cause a system fault. The host interrupt controller is responsible for ensuring that these latency issues are mitigated. The recommended solution is to delay EOIs and ISR Reads to the interrupt controller by the same amount as the SER_IRQ Cycle latency in order to ensure that these events do not occur out of order.

AC/DC SPECIFICATION ISSUE

All SER_IRQ agents must drive / sample SER_IRQ synchronously related to the rising edge of PCI bus clock. The SER_IRQ pin uses the electrical specification of PCI bus. Electrical parameters will follow PCI spec. section 4, sustained tri-state.

RESET AND INITIALIZATION

The SER_IRQ bus uses PCI_RESET# as its reset signal. The SER_IRQ pin is tri-stated by all agents while PCI_RESET# is active. With reset, SER_IRQ Slaves are put into the (continuous) IDLE mode. The Host Controller is responsible for starting the initial SER_IRQ Cycle to collect system's IRQ/Data default values. The system then follows with the Continuous/Quiet mode protocol (Stop Frame pulse

width) for subsequent SER_IRQ Cycles. It is Host Controller's responsibility to provide the default values to 8259's and other system logic before the first SER_IRQ Cycle is performed. For SER_IRQ system suspend, insertion, or removal application, the Host controller should be programmed into Continuous (IDLE) mode first. This is to guarantee SER_IRQ bus is in IDLE state before the system configuration changes.

Chapter 12 8042 Keyboard Controller Description

The SCH311X is a Super I/O and Universal Keyboard Controller that is designed for intelligent keyboard management in desktop computer applications. The Universal Keyboard Controller uses an 8042 microcontroller CPU core. This section concentrates on the SCH311X enhancements to the 8042. For general information about the 8042, refer to the "Hardware Description of the 8042" in the *8-Bit Embedded Controller Handbook*.

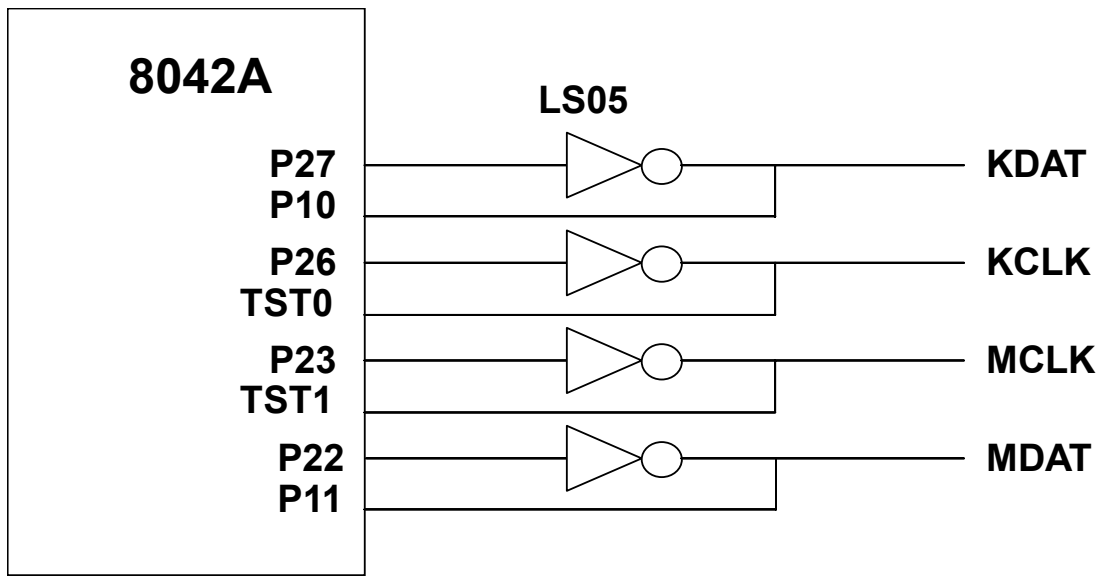

Keyboard and Mouse Interface

Figure 12.1 SCH311X Keyboard and Mouse Interface

KIRQ is the Keyboard IRQ

MIRQ is the Mouse IRQ

Port 21 is used to create a GATEA20 signal from the SCH311X.

12.1 Keyboard Interface

The SCH311X LPC interface is functionally compatible with the 8042 style host interface. It consists of the D0-7 data signals; the read and write signals and the Status register, Input Data register, and Output Data register. [Table 12.1](#) shows how the interface decodes the control signals. In addition to the above signals, the host interface includes keyboard and mouse IRQs.

Table 12.1 I/O Address Map

ADDRESS	COMMAND	BLOCK	FUNCTION (SEE NOTE)
0x60	Write	KDATA	Keyboard Data Write (C/D=0)
	Read	KDATA	Keyboard Data Read
0x64	Write	KDCTL	Keyboard Command Write (C/D=1)
	Read	KDCTL	Keyboard Status Read
Note: These registers consist of three separate 8-bit registers. Status, Data/Command Write and Data Read.			

Keyboard Data Write

This is an 8 bit write only register. When written, the C/D status bit of the status register is cleared to zero and the IBF bit is set.

Keyboard Data Read

This is an 8 bit read only register. If enabled by “ENABLE FLAGS”, when read, the KIRQ output is cleared and the OBF flag in the status register is cleared. If not enabled, the KIRQ and/or AUXOBF1 must be cleared in software.

Keyboard Command Write

This is an 8 bit write only register. When written, the C/D status bit of the status register is set to one and the IBF bit is set.

Keyboard Status Read

This is an 8 bit read only register. Refer to the description of the Status Register for more information.

CPU-to-Host Communication

The SCH311X CPU can write to the Output Data register via register DBB. A write to this register automatically sets Bit 0 (OBF) in the Status register. See [Table 12.2](#).

Table 12.2 Host Interface Flags

8042 INSTRUCTION	FLAG
OUT DBB	Set OBF, and, if enabled, the KIRQ output signal goes high

Host-to-CPU Communication

The host system can send both commands and data to the Input Data register. The CPU differentiates between commands and data by reading the value of Bit 3 of the Status register. When bit 3 is “1”, the CPU interprets the register contents as a command. When bit 3 is “0”, the CPU interprets the register contents as data. During a host write operation, bit 3 is set to “1” if SA2 = 1 or reset to “0” if SA2 = 0.

KIRQ

If “EN FLAGS” has been executed and P24 is set to a one: the OBF flag is gated onto KIRQ. The KIRQ signal can be connected to system interrupt to signify that the SCH311X CPU has written to the output data register via “OUT DBB,A”. If P24 is set to a zero, KIRQ is forced low. On power-up, after

Datasheet

a valid RST pulse has been delivered to the device, KIRQ is reset to 0. KIRQ will normally reflect the status of writes "DBB". (KIRQ is normally selected as IRQ1 for keyboard support.)

If "EN FLAGS" has not been executed: KIRQ can be controlled by writing to P24. Writing a zero to P24 forces KIRQ low; a high forces KIRQ high.

MIRQ

If "EN FLAGS" has been executed and P25 is set to a one; IBF is inverted and gated onto MIRQ. The MIRQ signal can be connected to system interrupt to signify that the SCH311X CPU has read the DBB register. If "EN FLAGS" has not been executed, MIRQ is controlled by P25, Writing a zero to P25 forces MIRQ low, a high forces MIRQ high. (MIRQ is normally selected as IRQ12 for mouse support).

Gate A20

A general purpose P21 is used as a software controlled Gate A20 or user defined output.

8042 PINS

The 8042 functions P17, P16 and P12 are implemented as in a true 8042 part. Reference the 8042 spec for all timing. A port signal of 0 drives the output to 0. A port signal of 1 causes the port enable signal to drive the output to 1 within 20-30nsec. After 500nsec (six 8042 clocks) the port enable goes away and the external pull-up maintains the output signal as 1.

In 8042 mode, the pins can be programmed as open drain. When programmed in open drain mode, the port enables do not come into play. If the port signal is 0 the output will be 0. If the port signal is 1, the output tristates: an external pull-up can pull the pin high, and the pin can be shared. In 8042 mode, the pins cannot be programmed as input nor inverted through the GP configuration registers.

12.2 External Keyboard and Mouse Interface

Industry-standard PC-AT-compatible keyboards employ a two-wire, bidirectional TTL interface for data transmission. Several sources also supply PS/2 mouse products that employ the same type of interface. To facilitate system expansion, the SCH311X provides four signal pins that may be used to implement this interface directly for an external keyboard and mouse.

The SCH311X has four high-drive, open-drain output, bidirectional port pins that can be used for external serial interfaces, such as external keyboard and PS/2-type mouse interfaces. They are KCLK, KDAT, MCLK, and MDAT. P26 is inverted and output as KCLK. The KCLK pin is connected to TEST0. P27 is inverted and output as KDAT. The KDAT pin is connected to P10. P23 is inverted and output as MCLK. The MCLK pin is connected to TEST1. P22 is inverted and output as MDAT. The MDAT pin is connected to P11.

Note: External pull-ups may be required.

12.2.1 Keyboard/Mouse Swap Bit

There is a Kbd/mouse Swap bit in the Keyboard Select configuration register located at 0xF1 in Logical Device 7. This bit can be used to swap the keyboard and mouse clock and data pins into/out of the 8042. The default value of this bit is '0' on VCC POR, VTR POR and PCI Reset.

1=internally swap the KCLK pin and the MCLK pin, and the KDAT pin and the MDAT pin into/out of the 8042.

0=do not swap the keyboard and mouse clock and data pins

12.3 Keyboard Power Management

The keyboard provides support for two power-saving modes: soft power-down mode and hard power-down mode. In soft power-down mode, the clock to the ALU is stopped but the timer/counter and interrupts are still active. In hard power down mode the clock to the 8042 is stopped.

Soft Power-Down Mode

This mode is entered by executing a HALT instruction. The execution of program code is halted until either RESET is driven active or a data byte is written to the DBBIN register by a master CPU. If this mode is exited using the interrupt, and the IBF interrupt is enabled, then program execution resumes with a CALL to the interrupt routine, otherwise the next instruction is executed. If it is exited using RESET then a normal reset sequence is initiated and program execution starts from program memory location 0.

Hard Power-Down Mode

This mode is entered by executing a STOP instruction. The oscillator is stopped by disabling the oscillator driver cell. When either RESET is driven active or a data byte is written to the DBBIN register by a master CPU, this mode will be exited (as above). However, as the oscillator cell will require an initialization time, either RESET must be held active for sufficient time to allow the oscillator to stabilize. Program execution will resume as above.

12.4 Interrupts

The SCH311X provides the two 8042 interrupts: IBF and the Timer/Counter Overflow.

12.5 Memory Configurations

The SCH311X provides 2K of on-chip ROM and 256 bytes of on-chip RAM.

12.6 Register Definitions

Host I/F Data Register

The Input Data register and Output Data register are each 8 bits wide. A write to this 8 bit register will load the Keyboard Data Read Buffer, set the OBF flag and set the KIRQ output if enabled. A read of this register will read the data from the Keyboard Data or Command Write Buffer and clear the IBF flag. Refer to the KIRQ and Status register descriptions for more information.

Host I/F Status Register

The Status register is 8 bits wide.

[Table 12.3](#) shows the contents of the Status register.

Table 12.3 Status Register

D7	D6	D5	D4	D3	D2	D1	D0
UD	UD	UD	UD	C/D	UD	IBF	OBF

Status Register

This register is cleared on a reset. This register is read-only for the Host and read/write by the SCH311X CPU.

UD Writable by SCH311X CPU. These bits are user-definable.

C/D (Command Data)-This bit specifies whether the input data register contains data or a command (0 = data, 1 = command). During a host data/command write operation, this bit is set to "1" if SA2 = 1 or reset to "0" if SA2 = 0.

IBF (Input Buffer Full)- This flag is set to 1 whenever the host system writes data into the input data register. Setting this flag activates the SCH311X CPU's nIBF (MIRQ) interrupt if enabled.

Datasheet

When the SCH311X CPU reads the input data register (DBB), this bit is automatically reset and the interrupt is cleared. There is no output pin associated with this internal signal.

OBF (Output Buffer Full) - This flag is set to whenever the SCH311X CPU write to the output data register (DBB). When the host system reads the output data register, this bit is automatically reset.

12.7 External Clock Signal

The SCH311X Keyboard Controller clock source is a 12 MHz clock generated from a 14.318 MHz clock. The reset pulse must last for at least 24 16 MHz clock periods. The pulse-width requirement applies to both internally (VCC POR) and externally generated reset signals. In power-down mode, the external clock signal is not loaded by the chip.

12.8 Default Reset Conditions

The SCH311X has one source of hardware reset: an external reset via the PCI_RESET# pin. Refer to [Table 12.4](#) for the effect of each type of reset on the internal registers.

Table 12.4 Resets

DESCRIPTION	HARDWARE RESET (PCI_RESET#)
KCLK	Low
KDAT	Low
MCLK	Low
MDAT	Low
Host I/F Data Reg	N/A
Host I/F Status Reg	00H
Note: N/A = Not Applicable	

GATEA20 AND KEYBOARD RESET

The SCH311X provides two options for GateA20 and Keyboard Reset: 8042 Software Generated GateA20 and KRESET and Port 92 Fast GateA20 and KRESET.

PORT 92 FAST GATEA20 AND KEYBOARD RESET

Port 92 Register

This port can only be read or written if Port 92 has been enabled via bit 2 of the KRST_GA20 Register (Logical Device 7, 0xF0) set to 1.

This register is used to support the alternate reset (nALT_RST) and alternate A20 (ALT_A20) functions.

NAME	PORT 92
Location	92h
Default Value	24h
Attribute	Read/Write
Size	8 bits

PORT 92 REGISTER	
BIT	FUNCTION
7:6	Reserved. Returns 00 when read
5	Reserved. Returns a 1 when read
4	Reserved. Returns a 0 when read
3	Reserved. Returns a 0 when read
2	Reserved. Returns a 1 when read
1	ALT_A20 Signal control. Writing a 0 to this bit causes the ALT_A20 signal to be driven low. Writing a 1 to this bit causes the ALT_A20 signal to be driven high.
0	Alternate System Reset. This read/write bit provides an alternate system reset function. This function provides an alternate means to reset the system CPU to effect a mode switch from Protected Virtual Address Mode to the Real Address Mode. This provides a faster means of reset than is provided by the Keyboard controller. This bit is set to a 0 by a system reset. Writing a 1 to this bit will cause the nALT_RST signal to pulse active (low) for a minimum of 1 μ s after a delay of 500 ns. Before another nALT_RST pulse can be generated, this bit must be written back to a 0.

NGATEA20		
8042 P21	ALT_A20	SYSTEM NA20M
0	0	0
0	1	1
1	0	1
1	1	1

Bit 0 of Port 92, which generates the nALT_RST signal, is used to reset the CPU under program control. This signal is AND'ed together externally with the reset signal (nKBDRST) from the keyboard controller to provide a software means of resetting the CPU. This provides a faster means of reset than is provided by the keyboard controller. Writing a 1 to bit 0 in the Port 92 Register causes this signal to pulse low for a minimum of 6 μ s, after a delay of a minimum of 14 μ s. Before another nALT_RST pulse can be generated, bit 0 must be set to 0 either by a system reset or a write to Port 92. Upon reset, this signal is driven inactive high (bit 0 in the Port 92 Register is set to 0).

Datasheet

If Port 92 is enabled, i.e., bit 2 of KRST_GA20 is set to 1, then a pulse is generated by writing a 1 to bit 0 of the Port 92 Register and this pulse is AND'ed with the pulse generated from the 8042. This pulse is output on pin KRESET and its polarity is controlled by the GPIO polarity configuration.

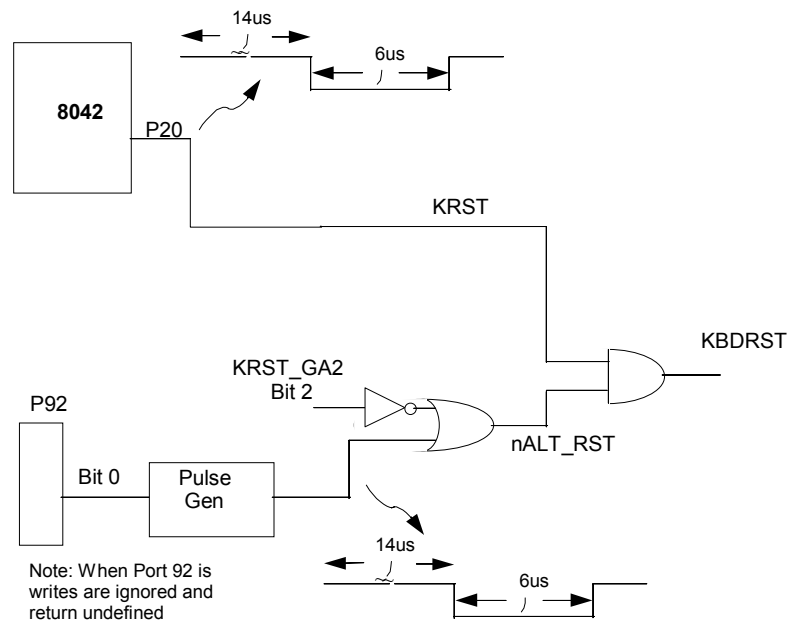

Bit 1 of Port 92, the ALT_A20 signal, is used to force nA20M to the CPU low for support of real mode compatible software. This signal is externally OR'ed with the A20GATE signal from the keyboard controller and CPURST to control the nA20M input of the CPU. Writing a 0 to bit 1 of the Port 92 Register forces ALT_A20 low. ALT_A20 low drives nA20M to the CPU low, if A20GATE from the keyboard controller is also low. Writing a 1 to bit 1 of the Port 92 Register forces ALT_A20 high. ALT_A20 high drives nA20M to the CPU high, regardless of the state of A20GATE from the keyboard controller. Upon reset, this signal is driven low.

Latches On Keyboard and Mouse IRQs

The implementation of the latches on the keyboard and mouse interrupts is shown below.

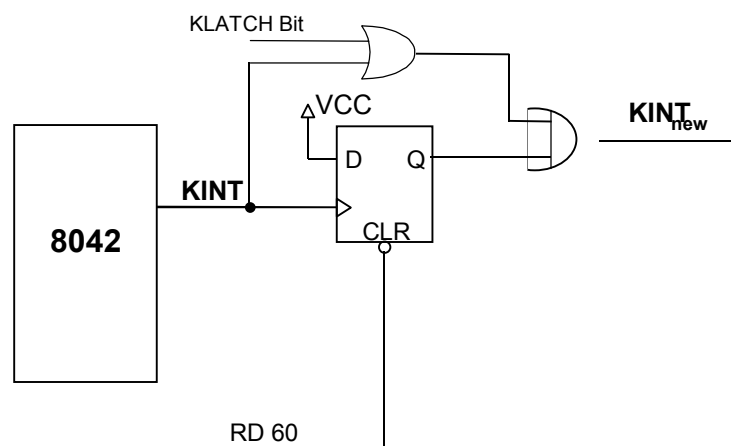
**Figure 12.2 Keyboard Latch**

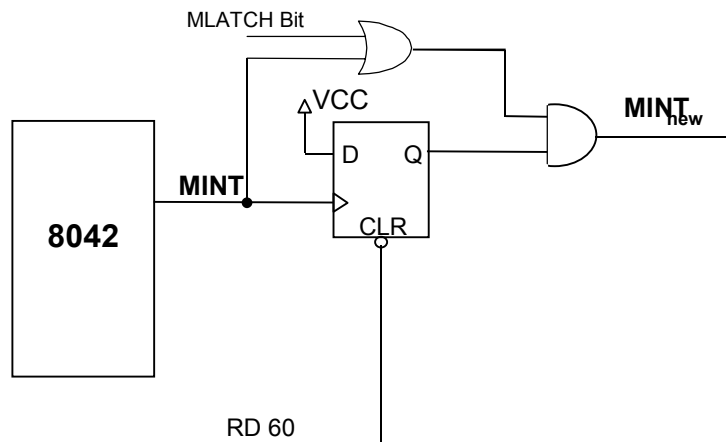
Figure 12.3 Mouse Latch

The KLATCH and MLATCH bits are located in the KRST_GA20 register, in Logical Device 7 at 0xF0.

These bits are defined as follows:

Bit[4]: MLATCH – Mouse Interrupt latch control bit. 0=MINT is the 8042 MINT ANDed with Latched MINT (default), 1=MINT is the latched 8042 MINT.

Bit[3]: KLATCH – Keyboard Interrupt latch control bit. 0=KINT is the 8042 KINT ANDed with Latched KINT (default), 1=KINT is the latched 8042 KINT.

See [Table 25.14, “KYBD. Logical Device 7 \[Logical Device Number = 0X07\],” on page 288](#) for a description of this register.

12.9 Keyboard and Mouse PME Generation

The SCH311X sets the associated PME Status bits when the following conditions occur:

Keyboard Interrupt

- Mouse Interrupt
- Active Edge on Keyboard Data Signal (KDAT)
- Active Edge on Mouse Data Signal (MDAT)

These events can cause a PME to be generated if the associated PME Wake Enable register bit and the global PME_EN bit are set. Refer to [Chapter 15, “PME Support,” on page 153](#) for more details on the PME interface logic and refer to [Chapter 26, “Runtime Register,” on page 293](#) for details on the PME Status and Enable registers.

The keyboard interrupt and mouse interrupt PMEs can be generated when the part is powered by VCC. The keyboard data and mouse data PMEs can be generated both when the part is powered by VCC, and when the part is powered by VTR (VCC=0).

When using the keyboard and mouse data signals for wakeup, it may be necessary to isolate the keyboard signals (KCLK, KDAT, MCLK, MDAT) from the 8042 prior to entering certain system sleep states. This is due to the fact that the normal operation of the 8042 can prevent the system from entering a sleep state or trigger false PME events. The SCH311X has “isolation” bits for the keyboard and mouse signals, which allow the keyboard and mouse data signals to go into the wakeup logic but block the clock and data signals from the 8042. These bits may be used anytime it is necessary to isolate the 8042 keyboard and mouse signals from the 8042 before entering a system sleep state.

See the PME_STS1 for more information.

Datasheet

The bits used to isolate the keyboard and mouse signals from the 8042 are located in Logical Device 7, Register 0xF0 (KRST_GA20) and are defined below. These bits reset on VTR POR only.

Bit[6] M_ISO. Enables/disables isolation of mouse signals into 8042. Does not affect the MDAT signal to The mouse wakeup (PME) logic.

1 = block mouse clock and data signals into 8042

0 = do not block mouse clock and data signals into 8042

Bit[5] K_ISO. Enables/disables isolation of keyboard signals into 8042. Does not affect the KDAT signal to the keyboard wakeup (PME) logic.

1 = block keyboard clock and data signals into 8042

0 = do not block keyboard clock and data signals into 8042

When the keyboard and/or mouse isolation bits are used, it may be necessary to reset the 8042 upon exiting the sleep state. If either of the isolation bits is set prior to entering a sleep state where VCC goes inactive (S3-S5), then the 8042 must be reset upon exiting the sleep mode. Write 0x40 to global configuration register 0x2C to reset the 8042. The 8042 must then be taken out of reset by writing 0x00 to register 0x2C since the bit that resets the 8042 is not self-clearing.

Caution: Bit 6 of configuration register 0x2C is used to put the 8042 into reset - do not set any of the other bits in register 0x2C, as this may produce undesired results.

It is not necessary to reset the 8042 if the isolation bits are used for a sleep state where VCC does not go inactive (S1, S2).

USER'S NOTE: Regarding External Keyboard and Mouse:

This is an application matter resulting from the behavior of the external 8042 in the keyboard.

When the external keyboard and external mouse are powered up, the KDAT and MDAT lines are driven low. This sets the KBD bit (D3) and the MOUSE bit (D4) of the PME Wake Status Register since the KDAT and MDAT signals cannot be isolated internal to the part. This causes an nIO_PME assertion to be generated if the keyboard and/or mouse PME events are enabled. Note that the keyboard and mouse isolation bits only prevent the internal 8042 in the part from setting these status bits.

Case 1: Keyboard and/or Mouse Powered by VTR

The KBD and/or MOUSE status bits will be set upon a VTR POR if the keyboard and/or mouse are powered by VTR.

In this case, a nIO_PME will not be generated, since the keyboard and mouse PME enable bits are reset to zero on a VTR POR. The BIOS software needs to clear these PME status bits after power-up.

In this case, an nIO_PME will be generated if the enable bits were set for wakeup, since the keyboard and mouse PME enable bits are Vbat powered. Therefore, if the keyboard and mouse are powered by VTR, the enable bits for keyboard and mouse events should be cleared prior to entering a sleep state where VTR is removed (i.e., S4 or S5) to prevent a false PME from being generated. In this case, the keyboard and mouse should only be used as PME and/or wake events from the power states S3 or below.

Case 2: Keyboard and/or Mouse Powered by VCC

The KBD and/or MOUSE status bits will be set upon a VCC POR if the keyboard and/or mouse are powered by VCC. In this case, a nIO_PME and a nIO_PME will be generated if the enable bits were set for wakeup, since the keyboard and mouse PME enable bits are VTR or Vbat powered. Therefore, if the keyboard and mouse are powered by VCC, the enable bits for keyboard and mouse events should be cleared prior to entering a sleep state where VCC is removed (i.e., S3) to prevent a false PME from being generated. In this case, the keyboard and mouse should only be used as PME and/or wake events from the S0 and/or S1 states. The BIOS software needs to clear these PME status bits after power-up.



Chapter 13 General Purpose I/O (GPIO)

The SCH311X provides a set of flexible Input/Output control functions to the system designer through the 40 independently programmable General Purpose I/O pins (GPIO). The GPIO pins can perform basic I/O and many of them can be individually enabled to generate an SMI and a PME.

13.1 GPIO Pins

The following pins include GPIO functionality. These pins are defined in the table below. All GPIOs default to the GPIO function except on indicated by [Note 13.3](#).

Table 13.1 GPIO Pin Functionality

GPIO PIN						
	PIN #	PIN NAME (DEFAULT FUNC/ ALTERNATE FUNCS)	GPIO PWRWELL	VTR POR	SMI/PME	NOTE
1.	85	GP10 GP10 / RXD3	VCC	0x01		13.3
2.	86	GP11 GP11 / TXD3	VTR	0x01		13.3
3.	96	GP12 GP12 / nDCD3	VTR	0x01		13.3
4.	95	GP13 GP13 / nRI3	VTR	0x01	PME	13.3 , 13.4
5.	87	GP14 GP14 / nDSR3	VTR	0x01		13.3
6.	92	GP15 GP15 / nDTR3	VCC	0x01		13.3
7.	89	GP16 GP16 / nCTS3	VCC	0x01		13.3
8.	88	GP17 GP17 / nRTS3	VCC	0x01		13.3
9.	37	KDAT/GP21	VCC	0x8C	SMI/PME	13.1 , 13.3
10.	38	KCLK/GP22	VCC	0x8C	SMI/PME	13.1 , 13.3
11.	36	GP27/nIO_SMI /P17	VCC	0x01	nIO_SMI/PM E	13.1
12.	110	nFPRST / GP30	VTR	0x05		13.3
13.	97	GP31 GP31 / nRI4	VTR	0x01	PME	13.3 , 13.4
14.	39	MDAT/GP32	VCC	0x84	SMI/PME	13.1 13.3
15.	40	MCLK/GP33	VCC	0x84	SMI/PME	13.1 13.3

Table 13.1 GPIO Pin Functionality (continued)

GPIO PIN						
	PIN #	PIN NAME (DEFAULT FUNC/ ALTERNATE FUNCS)	GPIO PWRWELL	VTR POR	SMI/PME	NOTE
16.	107	GP34 GP34 / nDTR4	VTR	0x01		13.3
17.	41	GP36/nKBDRST	VCC	0x01	-	
18.	42	GP37/A20M	VCC	0x01	-	
19.	3	GP40/DRVDEN0	VCC	0x01	-	
20.	90	GP42/nIO_PME	VTR	0x01	SMI	
21.	30	nIDE_RSTDRV / GP44 GP44 / TXD6	VCC	0x01		13.3
22.	31	nPCI_RST1 / GP45 GP45 / RXD6	VTR	0x01		13.3
23.	32	nPCI_RST2 / GP46 GP46 / nSCIN6	VTR	0x01	PME	13.3, 13.4
24.	33	nPCI_RST3 / GP47 GP47 / nSCOUT6	VTR	0x01		13.3
25.	71	GP50/nRI2	VCC	0x01	PME	13.1
26.	74	GP51/nDCD2	VCC	0x01	PME	13.1
27.	75	GP52/RXD2(IRRX)	VCC	0x01	PME	13.1
28.	76	GP53/TXD2 (IRTX)	VCC	0x01	PME	13.1
29.	77	GP54/nDSR2	VCC	0x01	SMI/PME	13.1
30.	78	GP55/nRTS2	VCC	0x01	SMI/PME	13.1
31.	79	GP56/nCTS2	VCC	0x01	SMI/PME	13.1
32.	80	GP57/nDTR2	VCC	0x01	SMI/PME	13.1
33.	94	GP60/nLED1/WDT	VTR	0x01	SMI/PME	13.1
34.	93	GP61/nLED2/ CLKO	VTR	0x01	SMI/PME	13.1
35.	106	GP62 GP62 / nCTS4	VTR	0x01		13.3
36.	98	GP63 GP63 / nDCD4	VTR	0x01		13.3
37.	102	GP64 GP64 / RXD4	VTR	0x01		13.3
38.	103	GP65 GP65 / TXD4	VTR	0x01		13.3
39.	104	GP66 GP66 / nDCR4	VTR	0x01		13.3

Table 13.1 GPIO Pin Functionality (continued)

		GPIO PIN				
	PIN #	PIN NAME (DEFAULT FUNC/ ALTERNATE FUNCS)	GPIO PWRWELL	VTR POR	SMI/PME	NOTE
40.	105	GP67 GP67 / nRTS4	VTR	0x01		13.3

Note 13.1 These pins are inputs to VCC and VTR powered logic.. The logic for the GPIO is on VCC - it is also a wake event which goes to VTR powered logic.

Note 13.2 This pin's primary function (power up default function) is not GPIO function; however, the pin can be configured a GPIO Alternate function.

Note 13.3 Not all alternate functions are available in all SCH311X devices. Refer to [Table 13.2, "SCH311X General Purpose I/O Port Assignments,"](#) on page 142 for more details.

Note 13.4 The PME is for the RI signal only. Note that this may not be available for all SCH311X devices. Refer to [Table 13.2, "SCH311X General Purpose I/O Port Assignments,"](#) on page 142 for more details.

13.2 Description

Each GPIO port has a 1-bit data register and an 8-bit configuration control register. The data register for each GPIO port is represented as a bit in one of the 8-bit GPIO DATA Registers, GP1 to GP6. The bits in these registers reflect the value of the associated GPIO pin as follows. Pin is an input: The bit is the value of the GPIO pin. Pin is an output: The value written to the bit goes to the GPIO pin. Latched on read and write. All of the GPIO registers are located in the PME block see [Chapter 26, "Runtime Register,"](#) on page 293. The GPIO ports with their alternate functions and configuration state register addresses are listed in [Table 13.2](#).

Table 13.2 SCH311X General Purpose I/O Port Assignments

RUN-TIME REG OFF-SET	SCH3112				SCH3114				SCH3116				GP DATA REG	GP DATA BIT
	DEF	ALT. FUNC. 1	ALT. FUNC. 2	ALT. FUNC. 3	DEF	ALT. FUNC. 1	ALT. FUNC. 2	ALT. FUNC. 3	DEF	ALT. FUNC. 1	ALT. FUNC. 2	ALT. FUNC. 3		
23	GPIO10				GPIO10	RXD3			GPIO10	RXD3			GP1 OFFSET 4B	0
24	GPIO11				GPIO11	TXD3			GPIO11	TXD3				1
25	GPIO12				GPIO12	nDCD3			GPIO12	nDCD3				2
26	GPIO13				GPIO13	nRI3			GPIO13	nRI3				3
27	GPIO14				GPIO14	nDSR3			GPIO14	nDSR3				4
29	GPIO15				GPIO15	nDTR3			GPIO15	nDTR3				5
2A	GPIO16				GPIO16	nCTS3			GPIO16	nCTS3				6
2B	GPIO17				GPIO17	nRTS3			GPIO17	nRTS3				7

Table 13.2 SCH311X General Purpose I/O Port Assignments (continued)

RUN-TIME REG OFF-SET	SCH3112				SCH3114				SCH3116				GP DATA REG	GP DATA BIT
	DEF	ALT. FUNC. 1	ALT. FUNC. 2	ALT. FUNC. 3	DEF	ALT. FUNC. 1	ALT. FUNC. 2	ALT. FUNC. 3	DEF	ALT. FUNC. 1	ALT. FUNC. 2	ALT. FUNC. 3		
	Reserved				Reserved				Reserved				GP2 OFFSET 4C	0
2C	KDAT (See Note 13.5)	GPIO21			KDAT (See Note 13.5)	GPIO21			KDAT (See Note 13.5)	GPIO21				1
2D	KCLK (See Note 13.5)	GPIO22			KCLK (See Note 13.5)	GPIO22			KCLK (See Note 13.5)	GPIO22				2
	Reserved				Reserved				Reserved					4:3
	Reserved				Reserved				Reserved					5
	Reserved				Reserved				Reserved					6
32	GPIO27	SMI Output	P17 (See Note 13.5)		GPIO27	SMI Output	P17 (See Note 13.5)		GPIO27	SMI Output	P17 (See Note 13.5)			7

Table 13.2 SCH311X General Purpose I/O Port Assignments (continued)

RUN-TIME REG OFF-SET	SCH3112				SCH3114				SCH3116				GP DATA REG	GP DATA BIT
	DEF	ALT. FUNC. 1	ALT. FUNC. 2	ALT. FUNC. 3	DEF	ALT. FUNC. 1	ALT. FUNC. 2	ALT. FUNC. 3	DEF	ALT. FUNC. 1	ALT. FUNC. 2	ALT. FUNC. 3		
33	nFPRST	GPIO30			nFPRST	GPIO30			nFPRST	GPIO30			GP3 OFFSET 4D	0
34	GPIO31				GPIO31	nRI4			GPIO31	nRI4				1
35	MDAT (See Note 13.5)	GPIO32			MDAT (See Note 13.5)	GPIO32			MDAT (See Note 13.5)	GPIO32				2
36	MCLK (See Note 13.5)	GPIO33			MCLK (See Note 13.5)	GPIO33			MCLK (See Note 13.5)	GPIO33				3
37	GPIO34				GPIO34	nDTR4			GPIO34	nDTR4				4
	Reserved				Reserved				Reserved					5
39	GPIO36	Keyboard Reset			GPIO36	Keyboard Reset			GPIO36	Keyboard Reset				6
3A	GPIO37	Gate A20			GPIO37	Gate A20			GPIO37	Gate A20				7

Rev 0.2 (09-28-04)

144
 DATASHEET

SMSC SCH311X



Table 13.2 SCH311X General Purpose I/O Port Assignments (continued)

RUN-TIME REG OFF-SET	SCH3112				SCH3114				SCH3116				GP DATA REG	GP DATA BIT
	DEF	ALT. FUNC. 1	ALT. FUNC. 2	ALT. FUNC. 3	DEF	ALT. FUNC. 1	ALT. FUNC. 2	ALT. FUNC. 3	DEF	ALT. FUNC. 1	ALT. FUNC. 2	ALT. FUNC. 3		
3B	GPIO40	Drive Density Select 0			GPIO40	Drive Density Select 0			GPIO40	Drive Density Select 0			GP4 OFFSET 4E	0
	Reserved				Reserved				Reserved					1
3D	GPIO42	nIO_PME			GPIO42	nIO_PME			GPIO42	nIO_PME				2
	Reserved				Reserved				Reserved					3
6E	nIDR_RSTDRV	GPIO44			nIDR_RSTDRV	GPIO44			GPIO44	TXD6				4
6F	nPCIRST1	GPIO45			nPCIRST1	GPIO45			GPIO45	RXD6				5
72	nPCIRST2	GPIO46			nPCIRST2	GPIO46			GPIO46	nSCIN6				6
73	nPCIRST3	GPIO47			nPCIRST3	GPIO47			GPIO47	nSCOUT6			7	

Rev 0.2 (09-28-04)

145
DATASHEET

SMSC SCH311X



Table 13.2 SCH311X General Purpose I/O Port Assignments (continued)

RUN-TIME REG OFF-SET	SCH3112				SCH3114				SCH3116				GP DATA REG	GP DATA BIT
	DEF	ALT. FUNC. 1	ALT. FUNC. 2	ALT. FUNC. 3	DEF	ALT. FUNC. 1	ALT. FUNC. 2	ALT. FUNC. 3	DEF	ALT. FUNC. 1	ALT. FUNC. 2	ALT. FUNC. 3		
3F	GPIO50	Ring Indicator 2			GPIO50	Ring Indicator 2			GPIO50	Ring Indicator 2			GP5 OFFSET 4F	0
40	GPIO51	Data Carrier Detect 2			GPIO51	Data Carrier Detect 2			GPIO51	Data Carrier Detect 2				1
41	GPIO52	Receive Serial Data 2			GPIO52	Receive Serial Data 2			GPIO52	Receive Serial Data 2				2
42	GPIO53	Transmit Serial Data 2			GPIO53	Transmit Serial Data 2			GPIO53	Transmit Serial Data 2				3
43	GPIO54	Data Set Ready 2			GPIO54	Data Set Ready 2			GPIO54	Data Set Ready 2				4
44	GPIO55	Request to Send 2			GPIO55	Request to Send 2			GPIO55	Request to Send 2				5
45	GPIO56	Clear to Send 2			GPIO56	Clear to Send 2			GPIO56	Clear to Send 2				6
46	GPIO57	Date Terminal Ready			GPIO57	Date Terminal Ready			GPIO57	Date Terminal Ready				7

Table 13.2 SCH311X General Purpose I/O Port Assignments (continued)

RUN-TIME REG OFF-SET	SCH3112				SCH3114				SCH3116				GP DATA REG	GP DATA BIT
	DEF	ALT. FUNC. 1	ALT. FUNC. 2	ALT. FUNC. 3	DEF	ALT. FUNC. 1	ALT. FUNC. 2	ALT. FUNC. 3	DEF	ALT. FUNC. 1	ALT. FUNC. 2	ALT. FUNC. 3		
47	GPIO60 Note 13.6	nLED1	WDT	WDT	GPIO60 Note 13.6	nLED1	WDT	WDT	GPIO60 Note 13.6	nLED1	WDT	WDT	GP6 OFFSET 50	0
48	GPIO61 Note 13.6	nLED2	CLKO		GPIO61 Note 13.6	nLED2	CLKO		GPIO61 Note 13.6	nLED2	CLKO			1
54	GPIO62 Note 13.7	nCTS4			GPIO62 Note 13.7	nCTS4			GPIO62 Note 13.7	nCTS4				2
55	GPIO63 Note 13.7	nDCD4			GPIO63 Note 13.7	nDCD4			GPIO63 Note 13.7	nDCD4				3
56	GPIO64 Note 13.7	RXD4			GPIO64 Note 13.7	RXD4			GPIO64 Note 13.7	RXD4				4
57	GPIO65 Note 13.7	TXD4			GPIO65 Note 13.7	TXD4			GPIO65 Note 13.7	TXD4				5
58	GPIO66 Note 13.7	nDSR4			GPIO66 Note 13.7	nDSR4			GPIO66 Note 13.7	nDSR4				6
59	GPIO67 Note 13.7	nRTS4			GPIO67 Note 13.7	nRTS4			GPIO67 Note 13.7	nRTS4				7

Note 13.5 When this pin function is selected, the associated GPIO pins have bi-directional functionality.

Note 13.6 These pins have Either Edge Triggered Interrupt (EETI) functionality. See [Section 13.5, "GPIO PME and SMI Functionality,"](#) on page 149 for more details.

Note 13.7 These pins have VID compatible inputs.

13.3 GPIO Control

Each GPIO port has an 8-bit control register that controls the behavior of the pin. These registers are defined in [Chapter 26, "Runtime Register," on page 293](#) section of this specification.

Each GPIO port may be configured as either an input or an output. If the pin is configured as an output, it can be programmed as open-drain or push-pull. Inputs and outputs can be configured as non-inverting or inverting. Bit[0] of each GPIO Configuration Register determines the port direction, bit[1] determines the signal polarity, and bit[7] determines the output driver type select. The GPIO configuration register Output Type select bit[7] applies to GPIO functions and the nSMI Alternate functions

The basic GPIO configuration options are summarized in .

Table 13.3 GPIO Configuration Option

SELECTED FUNCTION	DIRECTION BIT	POLARITY BIT	DESCRIPTION
	B0	B1	
GPIO	0	0	Pin is a non-inverted output.
	0	1	Pin is an inverted output.
	1	0	Pin is a non-inverted input.
	1	1	Pin is an inverted input.

The following GPIO have limited functionality as indicated in the notes in [Table 13.1, "GPIO Pin Functionality," on page 139](#): GP10, GP11, GP12, GP13, GP14, GP42. The corresponding GPIO Control Register have read only bits in position 0, 1, and/or 7.

13.4 GPIO Operation

The operation of the GPIO ports is illustrated in [Figure 13.1](#).

When a GPIO port is programmed as an input, reading it through the GPIO data register latches either the inverted or non-inverted logic value present at the GPIO pin. Writing to a GPIO port that is programmed as an input has no effect ([Table 13.4](#))

When a GPIO port is programmed as an output, the logic value or the inverted logic value that has been written into the GPIO data register is output to the GPIO pin. Reading from a GPIO port that is programmed as an output returns the last value written to the data register ([Table 13.4](#)). When the GPIO is programmed as an output, the pin is excluded from the PME and SMI logic.

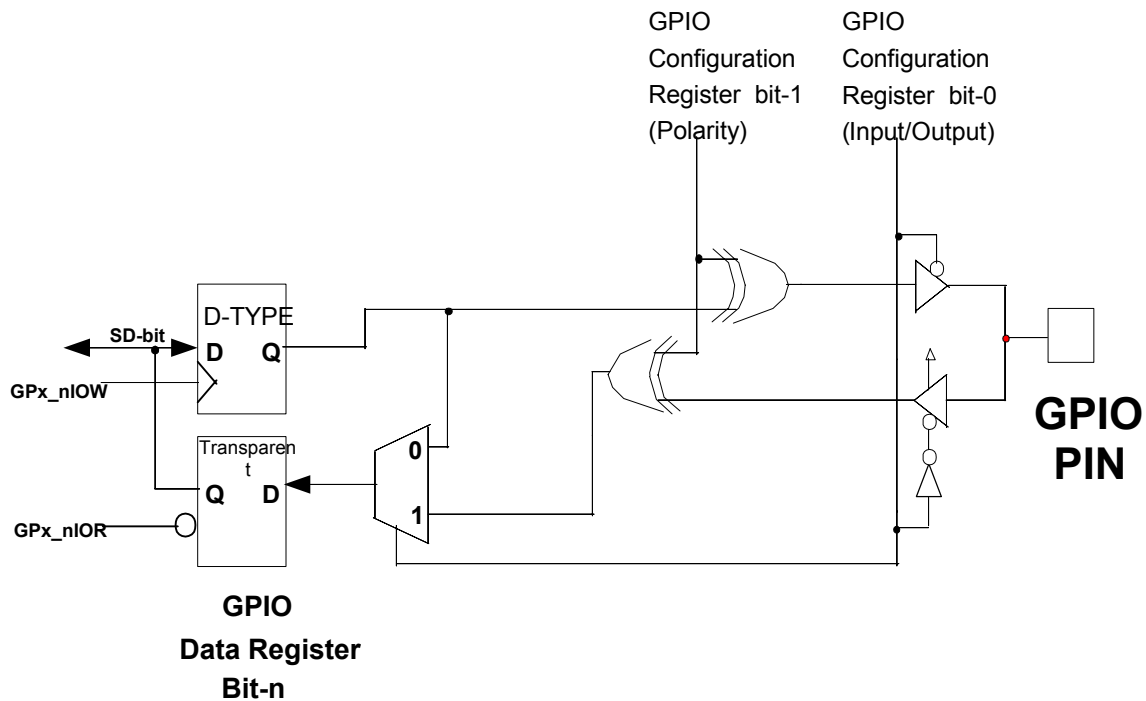

Figure 13.1 GPIO Function Illustration

Note: Figure 13.1 is for illustration purposes only and is not intended to suggest specific implementation details.

Table 13.4 GPIO Read/Write Behavior

HOST OPERATION	GPIO INPUT PORT	GPIO OUTPUT PORT
READ	LATCHED VALUE OF GPIO PIN	LAST WRITE TO GPIO DATA REGISTER
WRITE	NO EFFECT	BIT PLACED IN GPIO DATA REGISTER

13.5 GPIO PME and SMI Functionality

The SCH311X provides GPIOs that can directly generate a PME. The polarity bit in the GPIO control registers select the edge on these GPIO pins that will set the associated status bit in a PME Status. For additional description of PME behavior see [Chapter 15, "PME Support," on page 153](#). The default is the low-to-high transition. In addition, the SCH311X provides GPIOs that can directly generate an SMI.

The following GPIOs are dedicated wakeup GPIOs with a status and enable bit in the PME status and enable registers:

GP21-GP22, GP27, GP32-GP33 are controlled by PME_STS1, PME_STS3, PME_EN1, PME_EN3 registers.

GP50-GP57 are controlled by PME_STS5, PME_EN5 registers.

GP60, GP61 are controlled by PME_STS6, and PME_EN6 registers.

The following GPIOs can directly generate an SMI and have a status and enable bit in the SMI status and enable registers.

GP21, GP22, GP54, GP55, GP56, GP57, GP60 are controlled by SMI_STS3, and SMI_EN3 registers.

GP32, GP33, GP42, GP61 are controlled by SMI_STS4, and SMI_EN4 registers.

The following GPIOs have "either edge triggered interrupt" (EETI) input capability: GP21, GP22, GP60, GP61. These GPIOs can generate a PME and an SMI on both a high-to-low and a low-to-high edge on the GPIO pin. These GPIOs have a status bit in the PME_STS1 status register that is set on both edges. The corresponding bits in the PME and SMI status registers are also set on both edges.

13.6 Either Edge Triggered Interrupts

Three GPIO pins are implemented such that they allow an interrupt (PME or SMI) to be generated on both a high-to-low and a low-to-high edge transition, instead of one or the other as selected by the polarity bit.

The either edge triggered interrupts (EETI) function as follows: If the EETI function is selected for the GPIO pin, then the bits that control input/output, polarity and open drain/push-pull have no effect on the function of the pin. However, the polarity bit does affect the value of the GP bit (i.e., register PME_STS1, bit 2 for GP22).

A PME or SMI interrupt occurs if the PME or SMI enable bit is set for the corresponding GPIO and the EETI function is selected on the GPIO. The PME or SMI status bits are set when the EETI pin transitions (on either edge) and are cleared on a write of '1'. There are also status bits for the EETIs located in the PME_STSX register, which are also cleared on a write of '1'. The MSC_STS register provides the status of all of the EETI interrupts within one register. The PME, SMI or MSC status is valid whether or not the interrupt is enabled and whether or not the EETI function is selected for the pin.

Miscellaneous Status Register (MSC_STS) is for the either edge triggered interrupt status bits. If the EETI function is selected for a GPIO then both a high-to-low and a low-to-high edge will set the corresponding MSC status bits. Status bits are cleared on a write of '1'. See [Chapter 26, "Runtime Register," on page 293](#) for more information.

The configuration register for the either edge triggered interrupt status bits is defined in [Chapter 26, "Runtime Register," on page 293](#).

13.7 LED Functionality

The SCH311X provides LED functionality on two GPIOs, GP60 and GP61. These pins can be configured to turn the LED on and off and blink independent of each other through the LED1 and LED2 runtime registers at offset 0x5D and 0x5E from the base address located in the primary base I/O address in Logical Device A.

The LED pins (GP60 and GP61) are able to control the LED while the part is under VTR power with VCC removed. In order to control a LED while the part is under VTR power, the GPIO pin must be configured for the LED function and either open drain or push-pull buffer type. In the case of open-drain buffer type, the pin is capable of sinking current to control the LED. In the case of push-pull buffer type, the part will source current. The part is also able to blink the LED under VTR power. The LED will not blink under VTR power (VCC removed) if the external 32KHz clock is not connected.

The LED pins can drive a LED when the buffer type is configured to be push-pull and the part is powered by either VCC or VTR, since the buffers for these pins are powered by VTR. This means they will source their specified current from VTR even when VCC is present.

The LED control registers are defined in [Chapter 26, "Runtime Register," on page 293](#).

Chapter 14 System Management Interrupt (SMI)

The SCH311X implements a “group” nIO_SMI output pin. The System Management Interrupt is a non-maskable interrupt with the highest priority level used for OS transparent power management. The nSMI group interrupt output consists of the enabled interrupts from each of the functional blocks in the chip and many of the GPIOs and the Fan tachometer pins. The GP27/nIO_SMI/P17 pin, when selected for the nIO_SMI function, can be programmed to be active high or active low via the polarity bit in the GP27 register. The output buffer type of the pin can be programmed to be open-drain or push-pull via bit 7 of the GP27 register. The nIO_SMI pin function defaults to active low, open-drain output.

The interrupts are enabled onto the group nSMI output via the SMI Enable Registers 1 to 4. The nSMI output is then enabled onto the group nIO_SMI output pin via bit[7] in the SMI Enable Register 2. The SMI output can also be enabled onto the serial IRQ stream (IRQ2) via Bit[6] in the SMI Enable Register 2. The internal SMI can also be enabled onto the nIO_PME pin. Bit[5] of the SMI Enable Register 2 (PME_STS1) is used to enable the SMI output onto the nIO_PME pin (GP42). This bit will enable the internal SMI output into the PME logic through the DEVINT_STS bit in PME_STS3. See PME_STS1 for more details.

An example logic equation for the nSMI output for SMI registers 1 and 2 is as follows:

$$\text{nSMI} = (\text{EN_PINT and IRQ_PINT}) \text{ or } (\text{EN_U2INT and IRQ_U2INT}) \text{ or } (\text{EN_U1INT and IRQ_U1INT}) \text{ or } (\text{EN_FINT and IRQ_FINT}) \text{ or } (\text{EN_MINT and IRQ_MINT}) \text{ or } (\text{EN_KINT and IRQ_KINT}) \text{ or } (\text{EN_IRINT and IRQ_IRINT}) \text{ or } (\text{ENP12 and IRQ_P12}) \text{ or } (\text{SPEMSE_EN and SPEMSE_STS})$$

Note: The prefixes EN and IRQ are used above to indicate SMI enable bit and SMI status bit respectively.

SMI Registers

The SMI event bits for the GPIOs and the Fan tachometer events are located in the SMI status and Enable registers 3-5. The polarity of the edge used to set the status bit and generate an SMI is controlled by the polarity bit of the control registers. For non-inverted polarity (default) the status bit is set on the low-to-high edge. If the EETI function is selected for a GPIO then both a high-to-low and a low-to-high edge will set the corresponding SMI status bit. Status bits for the GPIOs are cleared on a write of ‘1’.

The SMI logic for these events is implemented such that the output of the status bit for each event is combined with the corresponding enable bit in order to generate an SMI.

The SMI registers are accessed at an offset from PME_BLK (see [Chapter 26, "Runtime Register," on page 293](#) for more information).

The SMI event bits for the super I/O devices are located in the SMI status and enable register 1 and 2. All of these status bits are cleared at the source except for IRINT, which is cleared by a read of the SMI_STS2 register; these status bits are not cleared by a write of ‘1’. The SMI logic for these events is implemented such that each event is directly combined with the corresponding enable bit in order to generate an SMI.

See the [Chapter 26, "Runtime Register," on page 293](#) for the definition of these registers.



Datasheet

Chapter 15 PME Support

The SCH311X offers support for power management events (PMEs), also referred to as a System Control Interrupt (SCI) events in an ACPI system. A power management event is indicated to the chipset via the assertion of the nIO_PME signal when in S5 or below power states.

APPLICATION NOTE: Software must properly configure the enable and status bits for the individual PME events in the registers described below. .

Table 15.1 describes the PME interface.

Table 15.1 PME Interface

NAME	BUFFER	POWER WELL	DESCRIPTION
nIO_PME	(O12/OD12)	VTR	General Purpose I/O. Power Management Event Output. This active low Power Management Event signal allows this device to request wakeup in S5 and below.

15.1 PME Events

All PME the events asserted on nIO_PME are listed in Table 15.2.

Table 15.2 PME Events

EVENTS	PME	COMMENT
Mouse		
by IRQ	Y (from group SMI)	
DATA pin edge sensitive	Y	
Specific Mouse Click	Y	See Section 15.5, "Wake on Specific Mouse Click," on page 156 for details
Keyboard		
Any Key	Y	
Specific Key	Y	
by IRQ	Y (from group SMI)	
Power button input		
Last state before Power Loss	Y	
FDC	Y (from group SMI)	
PIO	Y (from group SMI)	
UART-1		
by IRQ	Y (from group SMI)	
by nRI1 pin	Y	

Table 15.2 PME Events (continued)

EVENTS	PME	COMMENT
UART-2		
by IRQ	Y (from group SMI)	
by nRI2 pin	Y	
UART-3		
by IRQ	Y (from group SMI)	
by nRI2 pin	Y	
UART-4		
by IRQ	Y (from group SMI)	
by nRI2 pin	Y	
UART-5		
by IRQ	Y (from group SMI)	
by nRI2 pin	Y	
UART-6		
by IRQ	Y (from group SMI)	
by nRI2 pin	Y	
Hardware Monitor	nHWM_INT	
Watch Dog Timer	Y	
GPIO, total 15 pins	Y	
Low-Battery	Y	Detect on VCC POR only not a S3 wakeup either

The PME function is controlled by the PME status and enable registers in the runtime registers block, which is located at the address programmed in configuration registers 0x60 and 0x61 in Logical

There are four types of registers which control PME events:

1. PME Wake Status register ([PME_STS1](#), [PME_STS3](#), [PME_STS5](#), [PME_STS6](#).) provides the status of individual wake events.
2. PME Wake Enable ([PME_EN1](#), [PME_EN3](#), [PME_EN5](#), [PME_EN6](#)) provides the enable for individual wake events.
3. PME Pin Enable Register ([PME_EN](#).) provides an enable for the PME output pins.
4. PME Pin Status Register ([PME_STS](#)) provides the status for the PME output pins.

See [Chapter 26, "Runtime Register," on page 293](#) for detailed register description

The following describes the behavior to the PME status bits for each event:

Each wake source has a bit in a PME Wake Status register which indicates that a wake source has occurred. The PME Wake Status bits are "sticky"(unless otherwise stated in bit description in [Chapter 26, "Runtime Register," on page 293](#)): once a status bit is set by the wake-up event, the bit will remain set until cleared by writing a '1' to the bit.

Each PME Wake Status register has a corresponding PME Wake Enable Register.

Datasheet

If the corresponding bit in both in a PME Wake Status register and the PME Wake Enable Register are set then the PME Pin Status Register bit is set. If both corresponding PME Pin Status and the PME Pin Enable Register bit are set then the IO_PME pinIO_PME pin will asserted.

For the GPIO events, the polarity of the edge used to set the status bit and generate a PME is controlled by the polarity bit of the GPIO control register. For non-inverted polarity (default) the status bit is set on the low-to-high edge. If the EETI function is selected for a GPIO then both a high-to-low and a low-to-high edge will set the corresponding PME status bits. Status bits are cleared on a write of '1'.

The PME Wake registers also include status and enable bits for the HW Monitor Block.

See [Section 12.9, "Keyboard and Mouse PME Generation," on page 136](#) for information about using the keyboard and mouse signals to generate a PME.

15.2 Enabling SMI Events onto the PME Pin

There is a bit in the PME Status Register 3 to show the status of the internal "group" SMI signal in the PME logic (if bit 5 of the SMI_EN2 register is set). This bit, DEVINT_STS, is at bit 3 of the PME_STS3 register. When this bit is clear, the group SMI output is inactive. When bit is set, the group SMI output is active. The corresponding Wake-up enable bit is DEVINT_EN, is at bit 3 of the PME_EN3 register.

Bit 5 of the SMI_EN2 register must also be set. This bit is cleared on a write of '1'.

15.3 PME Function Pin Control

The GP42/nIO_PME pin, when selected for the nIO_PME function, can be programmed to be active high or active low via the polarity bit in the [GP42](#) register. The output buffer type of the pin can be programmed to be open-drain or push-pull via bit 7 of the [GP42](#) register. The nIO_PME pin function defaults to active low, open-drain output; however the GP42/nIO_PME pin defaults to the GP42 function.

In the SCH311X the nIO_PME pin can be programmed to be an open drain, active low, driver. The SCH311X nIO_PME pin are fully isolated from other external devices that might pull the signal low; i.e., the nIO_PME pin are capable of being driven high externally by another active device or pull-up even when the SCH311X VCC is grounded, providing VTR power is active. The IO_PME pin driver sinks 6mA at 0.55V max (see section 4.2.1.1 DC Specifications in the "PCI Local Bus Specification, Revision 2.2, December 18, 1998).

15.4 Wake on Specific Key Code

The SCH311X Wake on Specific Key Code feature is enabled for the assertion of the nIO_PME signal in SX power states by the SPEKEY bit in the [PME_STS6](#) register. This bit defaults to enabled and is Vbat powered.

At Vbat POR the Wake on Specific Key Code feature is disabled. During the first VTR POR and VCC POR the Wake on Specific Key Code feature remains disabled. Software selects the precise Specific Key Code event (configuration) to wake the system and then enables the feature via the SPEKEY bit in the [PME_STS6](#) register. The system then may go the sleep and/or have a power failure. After returning to or remaining in S5 sleep, the system will fully awake by a Wake on Specific Key Code. The Specific Key Code configuration and the enable for the nIO_PME are retained via Vbat POR backed registers.

The SCH311X Wake on Specific Key Code feature is enabled for assertion of the nIO_PME signal when in S3 power state or below by the SPEKEY bit in the [PME_EN6](#) register. This bit defaults to disabled and is VTR powered.

15.5 Wake on Specific Mouse Click

The SPESME SELECT field in the [Mouse_Specific_Wake](#) Register selects which mouse event is routed to the [PME_STS6](#) if enabled by [PME_EN6](#). The KB_MSE_SWAP bit in the [Mouse_Specific_Wake](#) Register can swap the Mouse port and Keyboard interfaces internally.

The Lock bit in the [Mouse_Specific_Wake](#) Register provides a means of changing access to read only to prevent tampering with the Wake on Mouse settings. The other bits in the [Mouse_Specific_Wake](#) Register are VBAT powered and reset on VBAT POR; therefore, the mouse event settings are maintained through a power failure. The lock bit also controls access to the [DBLCLICK](#) Register.

The [DBLCLICK](#) register contains a numeric value that determines the time interval used to check for a double mouse click. The value is the time interval between mouse clicks. For example, if [DBLCLICK](#) is set to 0.5 seconds, you have one half second to click twice for a double-click.

The larger the value in the [DBLCLICK](#) Register, the longer you can wait between the first and second click for the SCH311X to interpret the two clicks as a double-click mouse wake event. If the [DBLCLICK](#) value is set to a very small value, even quick double clicks may be interpreted as two single clicks.

The [DBLCLICK](#) register has a six bit weighted sum value from 0 to 0x3Fh which provides a double click interval between 0.0859375 and 5.5 seconds. Each incremental digit has a weight of 0.0859375 seconds.

The [DBLCLICK](#) Register is VBAT powered and reset on VBAT POR; therefore, the double click setting is maintained through a power failure. The default setting provides a 1.03125 second time interval.

[DBLCLICK](#) Writing to the [DBLCLICK](#) register shall reset the Mouse Wake-up internal logic and initialize the Mouse Wake-up state machines. The SPEMSE_EN bit in of the CLOCKI32 configuration register at 0xF0 in Logical Device A is used to control the "Wake on Specific Mouse Click" feature. This bit is used to turn the logic for this feature on and off. It will disable the 32KHz clock input to the logic. The logic will draw no power when disabled. The bit is defined as follows:

0= "Wake on Specific Mouse Click" logic is on (default)

1= "Wake on Specific Mouse Click" logic is off

The generation of a PME for this event is controlled by the PME enable bits (SPEMSE_EN bit in the [PME_EN6](#) register and in the [SMI_EN2](#) register) when the logic for feature is turned on. See [Section 15.5, "Wake on Specific Mouse Click," on page 156](#).

APPLICATION NOTE: The Wake on Specific Mouse Click feature requires use of the M_ISO bit in the KRST_GA20 register. SMSC Application Note 8.8 titled "Keyboard and Mouse Wake-up Functionality".

When using the wake on specific mouse event, it may be necessary to isolate the Mouse Port signals (MCLK, MDAT) from the 8042 prior to entering certain system sleep states. This is due to the fact that the normal operation of the 8042 can prevent the system from entering a sleep state or trigger false PME events. SCH311X has an "isolation" bit for the mouse signals, which allows the mouse data signals to go into the wake-up logic but block the clock and data signals from the 8042.

When the mouse isolation bit are used, it may be necessary to reset the 8042 upon exiting the sleep state. If M_SIO bit is set prior to entering a sleep state where VCC goes inactive (S3-S5), then the 8042 must be reset upon exiting the sleep mode. Write 0x40 to global configuration register 0x2C to reset the 8042. The 8042 must then be taken out of reset by writing 0x00 to register 0x2C since the bit that resets the 8042 is not self-clearing. Caution: Bit 6 of configuration register 0x2C is used to put the 8042 into reset - do not set any of the other bits in register 0x2C, as this may produce undesired results.

Datasheet

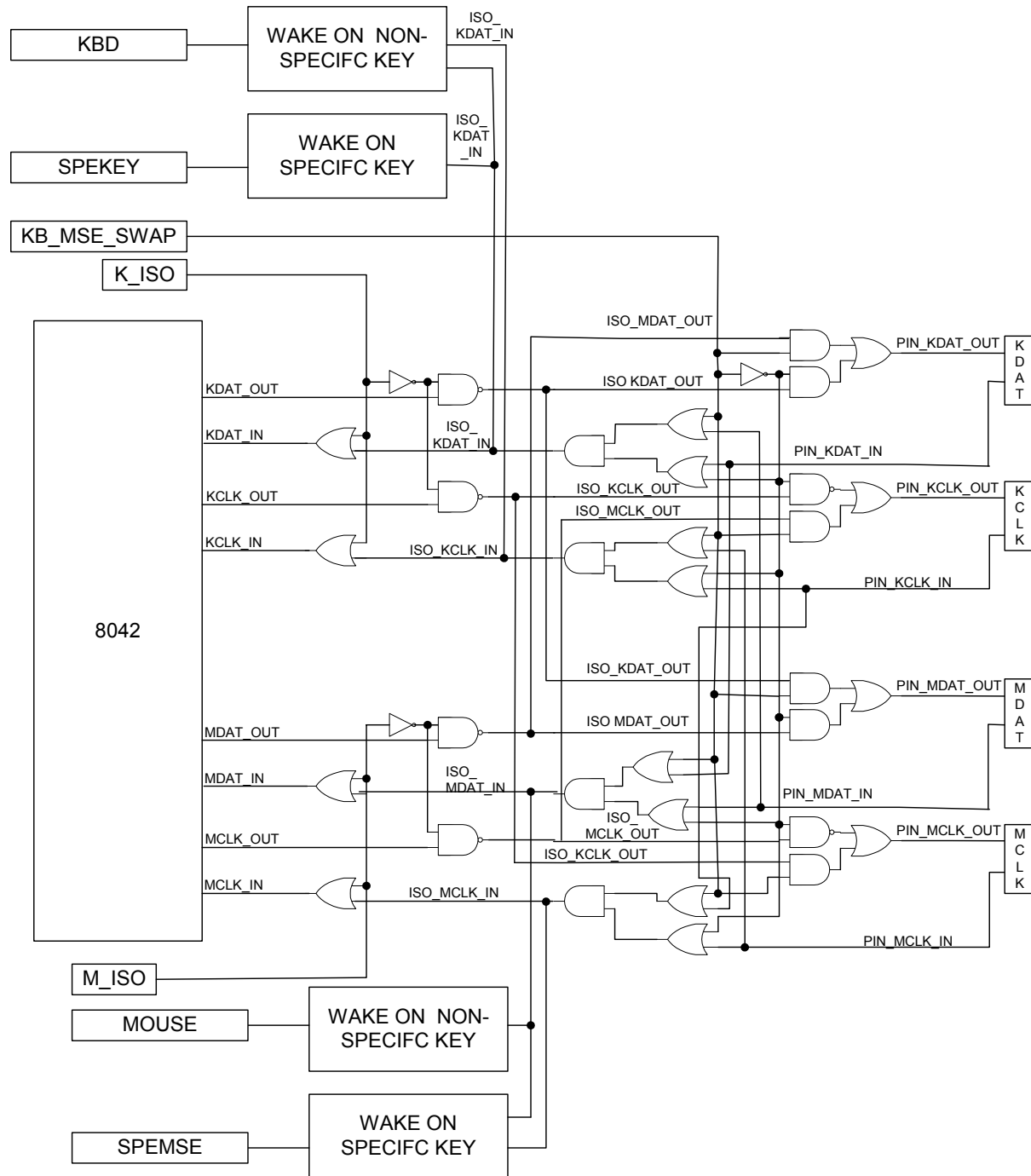

Figure 15.1 8042 Isolation and Keyboard and Mouse Port Swap Representation

Note: This figure is for illustration purposes only and not meant to imply specific implementation details



Chapter 16 Watchdog Timer

The SCH311X contains a Watchdog Timer (WDT). The Watchdog Time-out status bit may be mapped to an interrupt through the WDT_CFG Runtime Register.

The SCH311X WDT has a programmable time-out ranging from 1 to 255 minutes with one minute resolution, or 1 to 255 seconds with 1 second resolution. The units of the WDT timeout value are selected via bit[7] of the WDT_TIMEOUT register. The WDT time-out value is set through the WDT_VAL Runtime register. Setting the WDT_VAL register to 0x00 disables the WDT function (this is its power on default). Setting the WDT_VAL to any other non-zero value will cause the WDT to reload and begin counting down from the value loaded. When the WDT count value reaches zero the counter stops and sets the Watchdog time-out status bit in the WDT_CTRL Runtime register. Note: Regardless of the current state of the WDT, the WDT time-out status bit can be directly set or cleared by the Host CPU.

Two system events can reset the WDT: a Keyboard Interrupt or a Mouse Interrupt. The effect on the WDT for each of these system events may be individually enabled or disabled through bits in the WDT_CFG Runtime register. When a system event is enabled through the WDT_CFG register, the occurrence of that event will cause the WDT to reload the value stored in WDT_VAL and reset the WDT time-out status bit if set. If both system events are disabled, the WDT_VAL register is not reloaded.

The Watchdog Timer may be configured to generate an interrupt on the rising edge of the Time-out status bit. The WDT interrupt is mapped to an interrupt channel through the WDT_CFG Runtime register. When mapped to an interrupt the interrupt request pin reflects the value of the WDT time-out status bit.

The host may force a Watchdog time-out to occur by writing a "1" to bit 2 of the WDT_CTRL (Force WD Time-out) Runtime register. Writing a "1" to this bit forces the WDT count value to zero and sets bit 0 of the WDT_CTRL (Watchdog Status). Bit 2 of the WDT_CTRL is self-clearing.

See the [Chapter 26, "Runtime Register,"](#) on [page 293](#) for description of these registers.



Datasheet

Chapter 17 Programmable Clock Output

A CLK_OUT pin is available on the SCH311X. This will output a programmable frequency between 0.5 Hz to 16 Hz, and have the following characteristics:

- Must run when Vcc is off - could use 32Khz clock
- Accuracy is not an issue
- CLOCK_OUT register at offset 3Ch in runtime registers with the following programming:
Options for 0.25, 0.5, 1, 2, 4, 8, or 16 Hz

APPLICATION NOTE: No attempt has been made to synchronize the clock. As a result, glitches will occur on the clock output when different frequencies are selected.

CLOCK Output Control Register VTR POR = 0x00	3C (R/W)	Bit[0] Enable 1= Output Enabled 0= Disable Clock output Bit[3:1] Frequency Select 000= 0.25 Hz 001= 0.50 Hz 010= 1.00 Hz 011= 2.00 Hz 100= 4.00 Hz 101= 8.00 Hz 110= 16 hz 111 = reserved Bit[7:4] Reserved
---	-------------	---



Chapter 18 Reset Generation

The SCH311X device has a Reset Generator with the following characteristics:

- output is open-drain PWRGD_OUT
- 3.3V, 3.3V VTR and 5V voltage trip monitors are ALWAYS a source for the PWRGD_OUT.
- An internal version of nTHERMTRIP signal from the HW monitor block, can be a source of PWRGD_OUT, selectable via a bit in the RESGEN register.
- A 1.6 sec watchdog timer can be a source for PWRGD_OUT, selectable via a bit in the RESGEN register. See [Section 18.1, "Watchdog Timer for Reset Generation," on page 164](#) for more details.
- The output pulse width is selectable via a strap option (see), between 200 msec (default) or 500 msec. This pulse is applied to PWRGD_OUT. The RESGEN strap is sampled at the deasserting edge of PCIRST# or VCC POR. The following table summarizes the strap option programming.

Table 18.1 RESGEN Strap Option

RESGEN	DELAY
1	200 msec delay (approximate) default
0	500 msec delay (approximate)

The programming for the RESGEN function is in the REGEN register, runtime register offset 1Dh as shown in [Table 18.2](#).

Table 18.2 RESGEN Programming

RESGEN default = 00h	1Dh (R/W)	Reset Generator Bit[0] WDT2_EN: Enable Watchdog timer Generation / Select 0= WDT Enabled - Source for PWRGD_OUT (Default) 1= WDT Disabled - Not source for PWRGD_OUT Bit[1] ThermTrip Source Select 0 = Thermtrip not source for PWRGD_OUT ((Default) 1 = Thermtrip source for PWRGD_OUT Bit[2] WDT2_CTL: WDT input bit Bit[7:3] Reserved
-------------------------	--------------	---

Output MUST be low for at least 100 msec after 5V and 3.3V rails are valid.

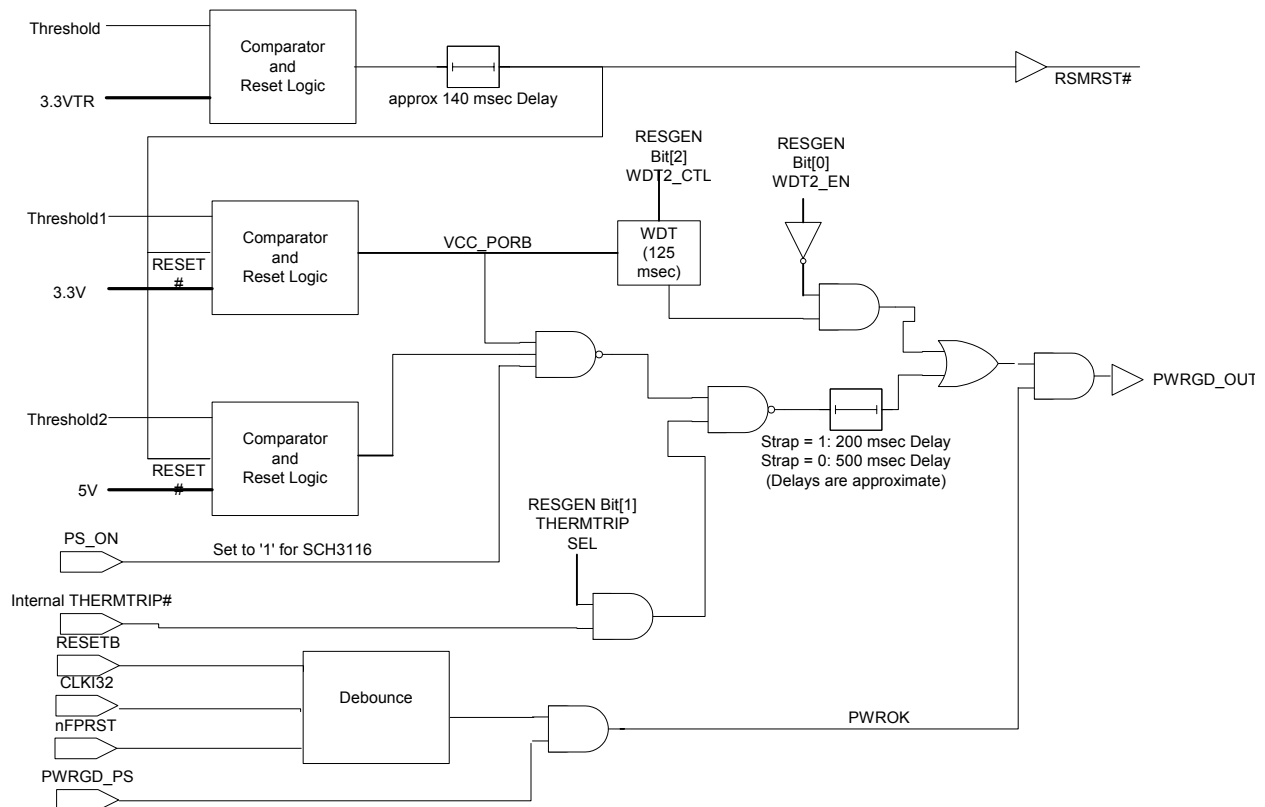

Figure 18.1 Reset Generation Circuit (For Illustrative Purposes Only)

18.1 Watchdog Timer for Reset Generation

The watchdog timer is a mechanism to monitor the host's activity. It is part of the reset generation circuitry. The Watchdog timer has the following characteristics:

- Feature enable/disable via a bit in a control register, accessible from the LPC. When enabled, WDT output is selected as a source for the PWRGD_OUT signal.
- Watchdog input bit in a the RESGEN register, WDT2_CTL, reset to 0 via VCC_POR, accessible from the LPC. See [Table 18.2](#).
- Counts upto 1.6 sec
- Counter reset by VCC_POR. The counter will remain reset as long as VCC_POR is active.
- Counter will start as soon as VCC_POR is released, and the toggle bit is set to one.
- If the host toggles the WDT2_CTL bit in control register, then counter is reset to 1.6 seconds and begins to count again.
- If the host does not toggle the WDT2_CTL bit in the control register before the WDT has timed out, a 125 msec pulse is output.
- After a timeout has occurred, a new timeout cycle does not begin until the host toggles the WDT2_CTL bit in control register. This causes the counter to be reset to 1.6 seconds and begins to count again

Datasheet

18.2 PWRGD_OUT Timing

the following figure illustrates the reset generation pulse timing based on normal power down and voltage trip conditions.

(a) Normal Power Down Due to PS_ON# Deasserted

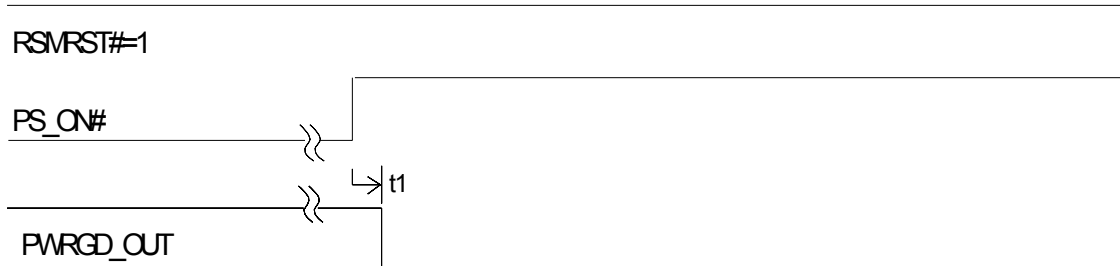

(b) Power Down Due to Drop in Power Supply

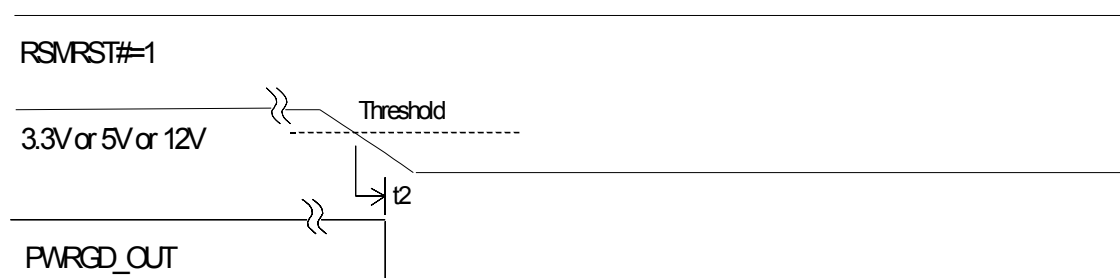

Figure 18.2 PWRGD_OUT Timing

Table 18.3 PWRGD_OUT Timing

Name	Description	Typical Value	Units
t1	PS_ON# pin high to PWRGD_OUT pin low	3	ns
t2	Power supply (at pin) drop below threshold to PWRGD_OUT pin low ¹	15	ns

Note: The time from the input pin to the output pin includes the output buffer delay.

18.3 Power Supply Voltage Scaling and Tolerances

The 5V supply is scaled internally. The input resistance is 20kohms (min). The voltage trip point is 4.45V (nominal) with a tolerance of $\pm 0.15V$ (range: 4.3V-4.6V).

For the 3.3V VTR and 3.3V supplies, the voltage trip point is 2.8V (nominal) with a tolerance of $\pm 0.1V$ (range: 2.7V-2.9V).



Chapter 19 Buffered PCI Outputs

19.1 Buffered PCI Outputs Interface

The SCH3112 and SCH3114 devices provide three software controlled PCIRST# outputs and one buffered IDE Reset.

APPLICATION NOTE: These outputs are not available on the SCH3116.

[Table 19.1](#) describes the interface.

Table 19.1 Buffered PCI outputs Interface

NAME	BUFFER	POWER WELL	DESCRIPTION
PCI_RESET#	PCI_I	VCC	PCI Reset Input
nIDE_RSTDRV	OD8	VCC	IDE Reset Output
nPCIRST1	OP14	VTR	Buffered PCI Reset Output
nPCIRST2	OP14	VTR	Buffered PCI Reset Output
nPCIRST3	OP14	VTR	Buffered PCI Reset Output

19.1.1 IDE Reset Output

nIDE_RSTDRV is an open drain buffered copy of PCI_RESET#. This signal requires an external 1K Ω pull-up to VCC or 5V. This pin is an output only pin which floats when VCC=0. The pin function's default state on VTR POR is the nIDE_RST function; however the pin function can be programmed to the a GPO pin function by bit 2 in the PME_STS1 GPIO control register.

The nIDE_RSTDRV output has a programmable forced reset. The software control of the programmable forced reset function is located in the GP4 GPIO Data register. When the GP44 bit (bit 4) is set, the nIDE_RSTDRV output follows the PCI_RESET# input; this is the default state on VTR POR. When the GP44 bit is cleared, the nIDE_RSTDRV output stays low.

See GP44 and GP4 for Runtime Register Description ([Chapter 26, "Runtime Register," on page 293](#)).

Table 19.2 nIDE_RSTDRV Truth Table

PCI_RESET# (INPUT)	nIDE_RSTDRV (OUTPUT)
0	0
1	Hi-Z

Table 19.3 nIDE_RSTDRV Timing

NAME	DESCRIPTION	MIN	TYP	MAX	UNITS
Tf	nIDE_RSTDRV high to low fall time. Measured from 90% to 10%			15	ns

Table 19.3 nIDE_RSTDRV Timing (continued)

NAME	DESCRIPTION	MIN	TYP	MAX	UNITS
Tpropf	nIDE_RSTDRV high to low propagation time. Measured from PCI_RESET# to nIDE_RSTDRV.			22	ns
CO	Output Capacitance			25	pF
CL	Load Capacitance			40	pF

19.1.2 nPCIRSTx Output Logic

The nPCIRST1, nPCIRST2, and nPCIRST3 outputs are 3.3V balance buffer push-pull buffered copies of PCI_RESET# input. Each pin function's default state on VTR POR is the nPCIRSTx function; however, the pin function can be programmed to the a GPO pin (output only) function by bit 2 in the corresponding GPIO control register (GP45, GP46, GP47).

Each nPCIRSTx output has a programmable force reset. The software control of the programmable forced reset function is located in the GP4 GPIO Data register. When the corresponding (GP45, GP46 GP47) bit in the GP4 GPIO Data register is set, the nPCIRSTx output follows the PCI_RESET# input; this is the default state on VTR POR. When the corresponding (GP45, GP46, GP47) bit in the GP4 GPIO Data register is cleared, the nPCIRSTx output stays low.

See GP4 for Runtime Register Description.

When the VTR power is applied, VCC is powered down, and the GPIO control register's contents are default, the nPCIRSTx pin output is low.

The [Figure 19.1](#) illustrates the nPCIRSTx function. The figure is for illustration purposes only and is not intended to suggest specific implementation details.

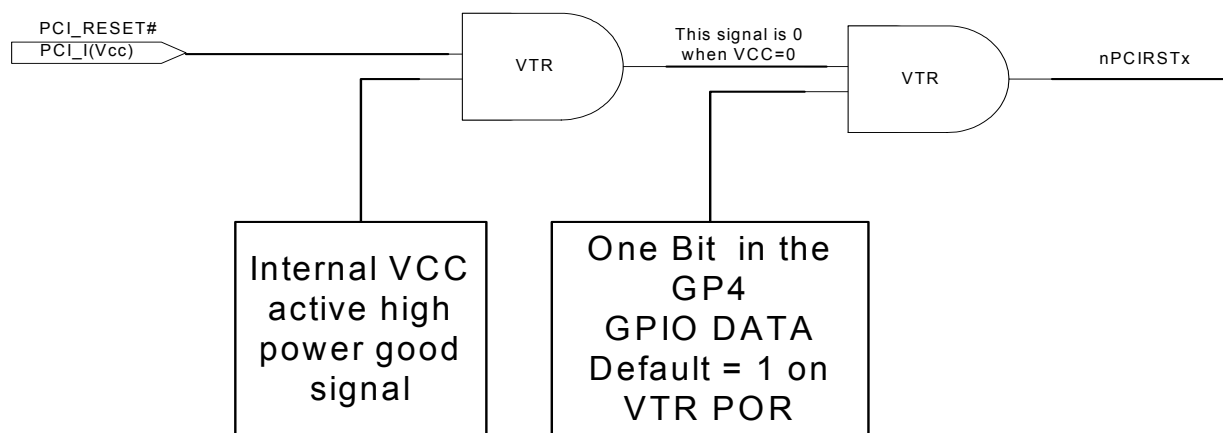

Note: This figure is for illustration purposes only and not meant to imply specific implementation details

Figure 19.1 nPCIRSTx Logic

Chapter 20 Power Control Features

APPLICATION NOTE: The following function is NOT available in the SCH3116 device.

The SCH3112 AND SCH3114 DEVICES are able to turn on the power supply when the power button located on the PC chassis is pressed, when the power button located on the keyboard is pressed, or when recovering from a power failure. The signals used to support these features are:

- PB_IN#
- PB_OUT#
- SLP_Sx#
- PS_ON#

Table 20.1 and Figure 20.1 describe the interface and connectivity of the following Power Control Features:

1. Front Panel Reset with Input Debounce, Power Supply Gate, and Powergood Output Signal Generation
2. AC Recovery Circuit
3. Keyboard Wake on Mouse.
4. SLP_Sx# PME wakeup

Table 20.1 Power Control Interface

NAME	DEVICE(S) SUPPORT	DIRECTION	DESCRIPTION
PB_IN#	SCH3112, SCH3114	Input	Power Button Input
PB_OUT#	SCH3112, SCH3114	Output	Power Good Output
PS_ON#	SCH3112, SCH3114	Output	Power Supply On output
SLP_SX#	SCH3112, SCH3114	Input	From south bridge
PWRGD_PS	SCH311X	Input	Power Good Input from Power Supply
nFPRST	SCH311X	Input	Reset Input from Front Panel
PWRGD_OUT	SCH311X	Output	Power Good Output – Open Drain
nIO_PME	SCH311X	Output	Power Management Event Output signal allows this device to request wakeup.

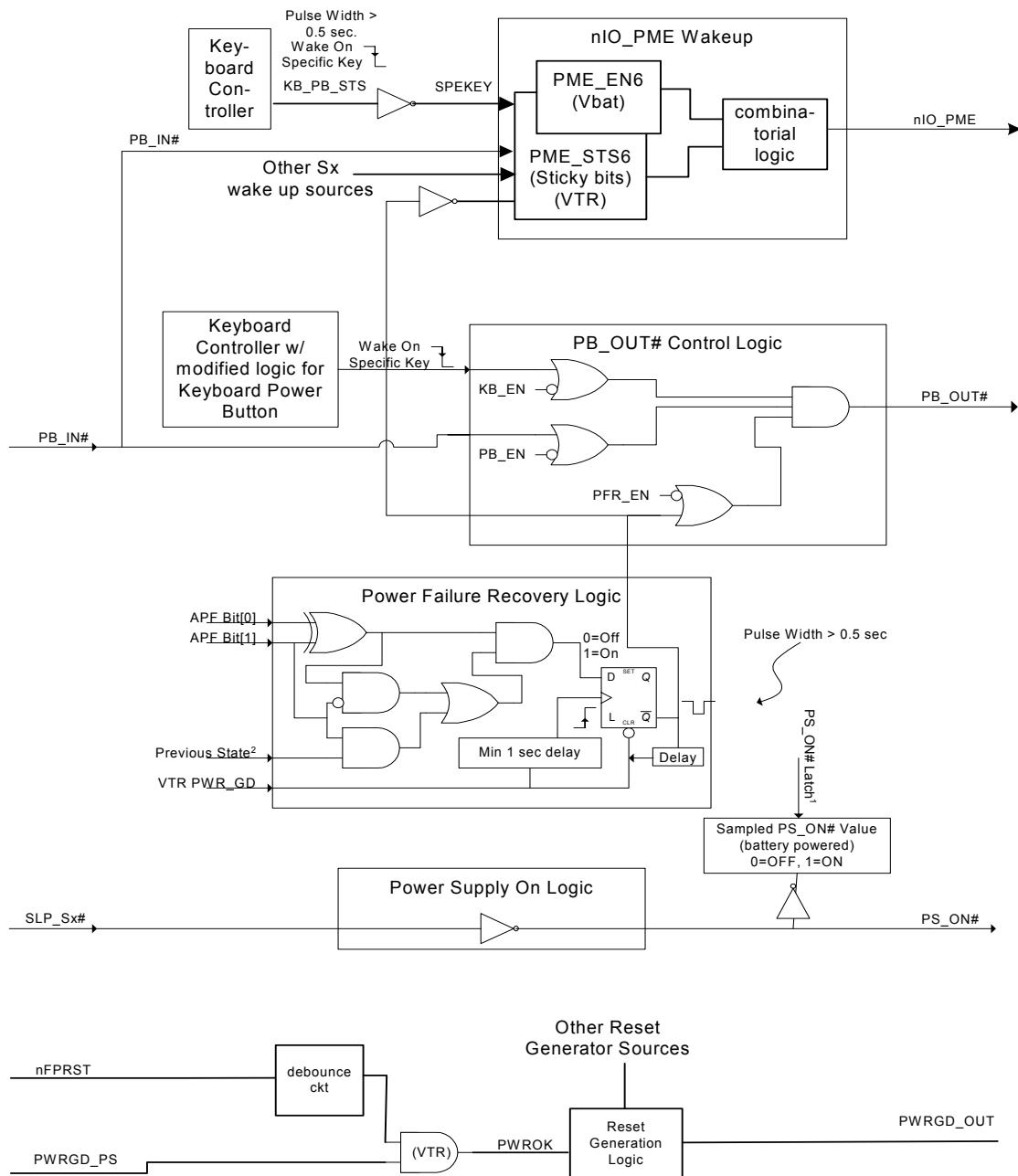
Figure 20.1 Power Control Block Diagram
Notes:

- The PS_ON# level will be latched in the Previous State bit located in the Power Recovery Register on the falling edge of VTR PWR_GD, VCC PWR_GD, or PWR_OK, which ever comes first. If mode 1 is enabled, this bit will be used to determine the Previous State.
- The Previous state is equal to the Previous State bit located in the Power Recover Register, if configured for Mode 1. If mode 2 is enabled, the Previous state is determined by one of the bits

Datasheet

in the 8-bit shift register, which is stored in the PS_ON register located in the Runtime Register block at 4Ah. The bit selected in mode 2 is determined by the the state of the PS_ON# Previous State Select bits located in Runtime Register 53h.

20.1 nIO_PME Pin use in Power Control

The nIO_PME signal can be used to control the state of the power supply. The nIO_PME signal will be asserted when a PME event occurs and the PME logic is enabled. The following is a summary of the Power control PME events (See [Figure 20.1](#)):

1. PB_IN# input signal assertion. (SCH3112, SCH3114 devices only)
2. When the Wake On Specific Key Logic detects the programmed keyboard event it will generate a wake event (KB_PB_STS).
3. Upon returning from a power failure.

Each PME wake event sets a status bit in the PME_STS6 register. If the corresponding enable bit in the PME_EN6 register is set then the nIO_PME pin will be asserted. The enable bits in the PME_EN6 register default to set and are Vbat powered. Refer to [Chapter 15, "PME Support," on page 153](#) for description of the PME support for this PME event.

20.2 Front Panel Reset

The inputs, PWRGD_PS and nFPRST have hysteresis and are internally pulled to VTR through a 30uA resistor. The nFPRST is debounced internally.

The nFPRST input has internal debounce circuitry that is valid on both edges for at least 16ms before the output is changed. The 32.768kHz is used to meet the timing requirement. See [Figure 20.2](#) for nFPRST debounce timing.

Note: The actual minimum debounce time is 15.8msec

The 32.768 kHz trickle input **must** be connected to supply the clock signal for the nFPRST debounce circuitry. The SCH311X has a legacy feature which is incompatible with use of the nFPRST input signal. An internal 32kHz clock source derived from the 14MHz (VCC powered) can be selected when the external 32kHz clock is not connected.

APPLICATION NOTE: The 32.768 kHz trickle input must be connected to supply the clock signal for the nFPRST debounce circuitry.

Table 20.2 Internal PWROK Truth Table

INPUTS		OUTPUT
nFPRST	PWRGD_PS	INTERNAL PWROK
0	0	0
0	1	0
1	0	0
1	1	1

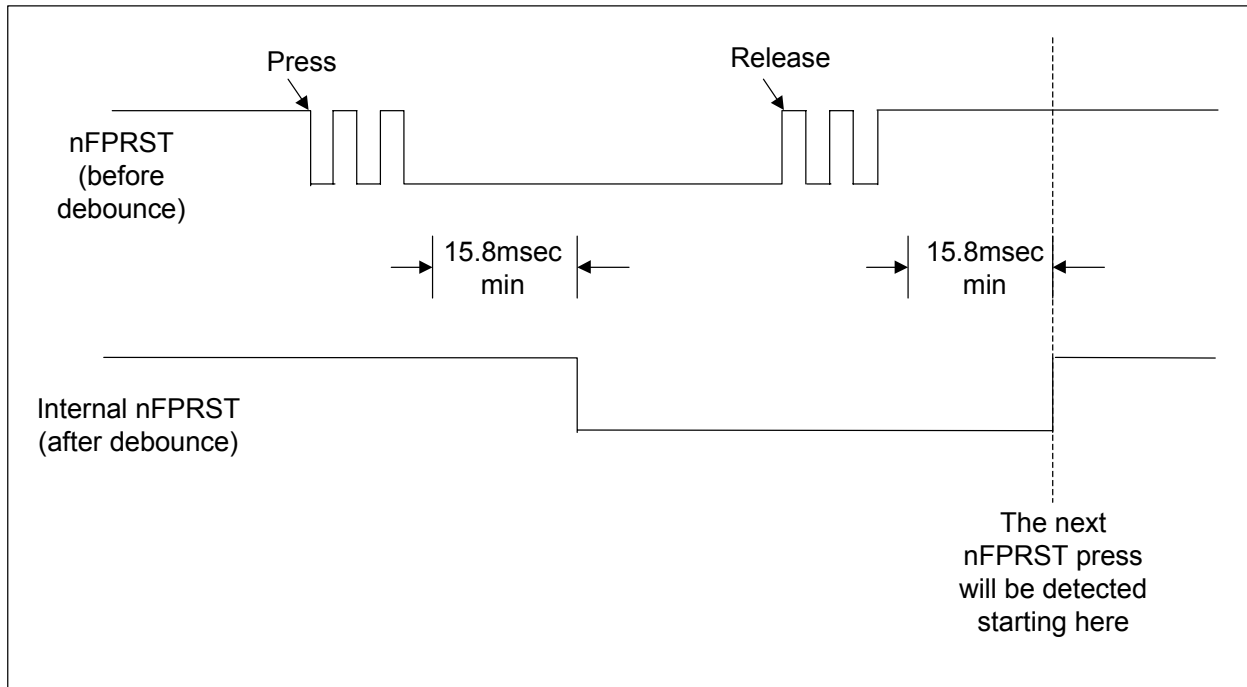

Figure 20.2 nFPRST Debounce Timing

20.3 A/C Power Failure Recovery Control (SCH3112 and SCH3114 Devices only)

The Power Failure Recovery Control logic, which is powered by VTR, is used to return a system to a pre-defined state after a power failure (VTR=0V). The Power Control Register, which is powered by Vbat, contains two bits defined as APF (After Power Failure). These bits are used to determine if the power supply should be powered on, powered off, or set to the previous power state before VTR was removed as shown in [Table 20.3](#).

Power Failure Recovery registers that are required to retain their state through a power failure are powered by Vbat.

Two modes may be used to determine the previous state:

Mode 1: (Suggested if PWR_OK is selected & enabled), which is enabled when Bit[3] PS_ON# sampling is disabled, latches the current value of the PS_ON# pin when VCC, VTR, or PWR_OK (if enabled) transition to the inactive state, whichever comes first. This value is latched into Bit[4] Previous State Bit located in the Power Recovery Register located at offset 49h and is used to determine the state of the PS_ON# pin when VTR becomes active.

Mode 2 is enabled when Bit[3] PS_ON# sampling is enabled. To determine the previous power state, the PS_ON# pin is sampled every 0.5 seconds while VTR is greater than ~2.2Volts. This sample is inserted into a battery powered 8-bit shift register. The hardware will select a bit from the shift register depending on the value of the PS_ON# Previous State Select bits located in the Runtime Register block at offset 53h to determine the state of the PS_ON# pin when VTR becomes active. The value in the 8-bit shift register is latched into the PS_ON Register at offset 4Ah in the Runtime Register block after VTR power is returned to the system, but before the internal shift register is cleared and activated. The PS_ON Register is a battery powered register that is only reset on a Vbat POR.

Notes:

- In Mode 2, when VTR falls below ~2.2Volts the current value of the PS_ON# pin will be latched into Bit [4] Previous State Bit located in the Power Recovery Register at offset 49h. This bit will





Datasheet

not be used by hardware, but may be read by software to determine the state of the PS_ON# pin when the power failure occurred.

- The time selected for the PS_ON# Previous State bits should be greater than or equal to the time it takes for Resume Reset to go inactive to the time VTR is less than ~2.2 Volts.

If a power failure occurs and the Power Supply should be in the ON state, the Power Failure Recovery logic will assert the PB_OUT# pin active low for a minimum pulse width of 0.5sec when VTR powers on. If the Power Supply should remain off, the Power Failure Recovery logic will have no effect on the PB_OUT# pin. The following table defines the possible states of PB_OUT# after a power failure for each configuration of the APF bits.

Table 20.3 Definition of APF Bits

APF[1:0]	DEFINITION OF APF BITS	AFTERG3 BIT (LOCATED IN ICH)	PB_OUT#
00 11	Power Supply OFF	1	
01	Power Supply ON	1	
10	Power Supply set to Previous State (ON)	1	
10	Power Supply set to Previous State (OFF)	1	

Note: It is a requirement that the AFTERG3 bit located in the ICH controller be programmed to 1 for this AC Recovery logic to be used.

20.3.1 PB_OUT# and PS_ON#

The PB_OUT# and PS_ON# signals are used to control the state of the power supply.

The PB_OUT# signal will be asserted low if the PB_IN# is asserted and enabled, if the KB_IN# is asserted and enabled, or if recovering from a power failure and the power supply should be turned on. Refer to [Figure 20.1](#). The following is a summary of these signals:

1. If the PB_IN# signal is enabled and asserted low, the PB_OUT# signal should be held low for as long as the PB_IN# signal is held low.
2. If the internal KB_PB_STS# signal (see [Figure 14](#)) is asserted low, the PB_OUT# signal is held low for as long as the KB_PB_STS# signal is held low.
3. If returning from a power failure and the power supply need to be turned on, a minimum of a ~0.5sec pulse is asserted on the PB_OUT# pin. Note: This pulse width is less than 4 seconds, since a 4 second pulse width signifies a power button override event.

The PS_ON# signal is the inverse of the SLP_Sx# input signal. This signal goes directly to the Power Supply to turn the supply on or off.

The SCH#11X indirectly controls the PS_ON# signal by asserting the PB_OUT#. PB_OUT# will be interpreted by an external device (i.e., ICH controller), which will use this information to control the SLP_Sx# signal.

Note: Two modes have been added to save the state of the PS_ON# pin in the event of a power failure. This allows the system to recover from a power failure. See [Section 20.3, "A/C Power Failure Recovery Control \(SCH3112 and SCH3114 Devices only\)," on page 172](#).

20.3.2 Power Supply Timing Diagrams

The following diagrams show the relative timing for the I/O pins associated with the Power Control logic. These are conceptual diagrams to show the flow of events.

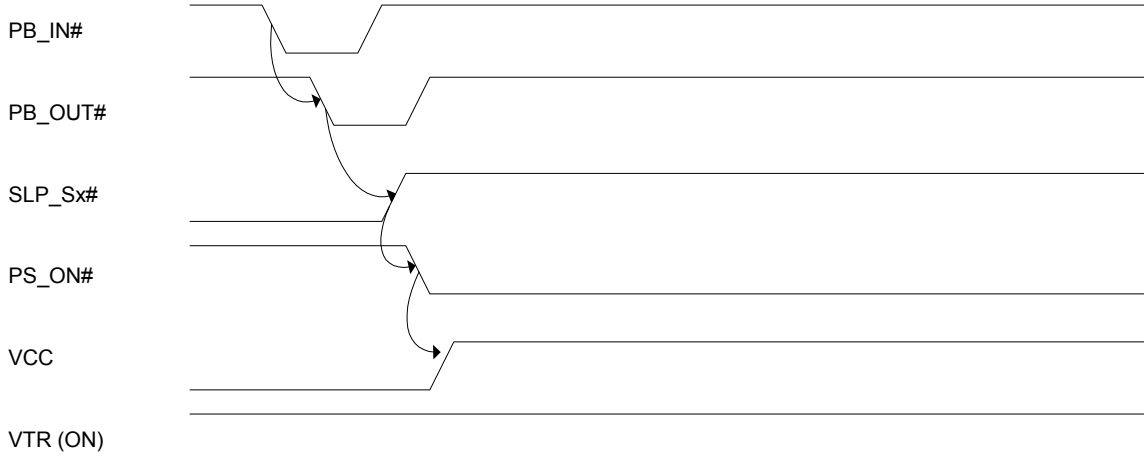

Figure 20.3 Power Supply during Normal Operation

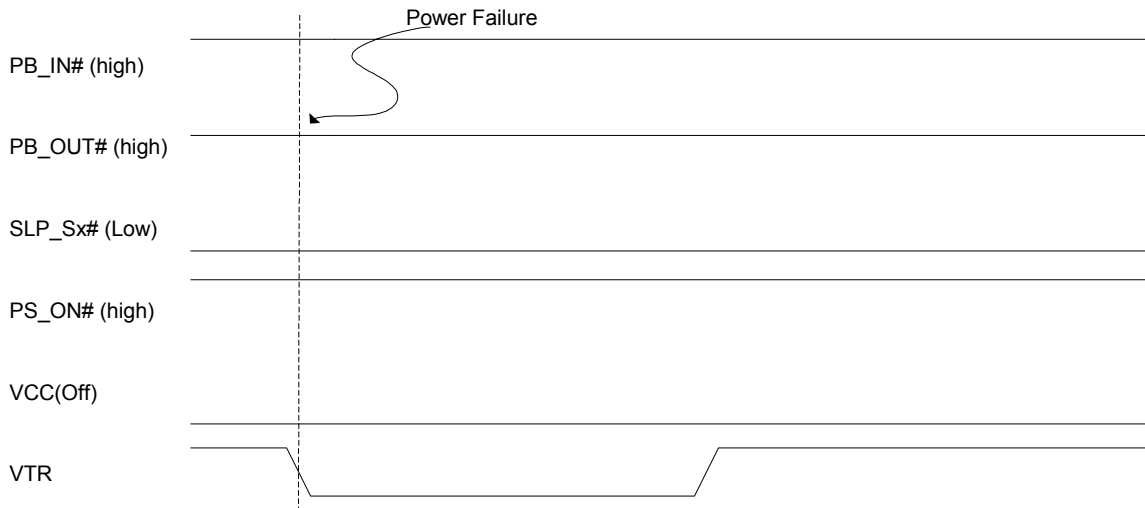

Figure 20.4 Power Supply After Power Failure (Return to Off)

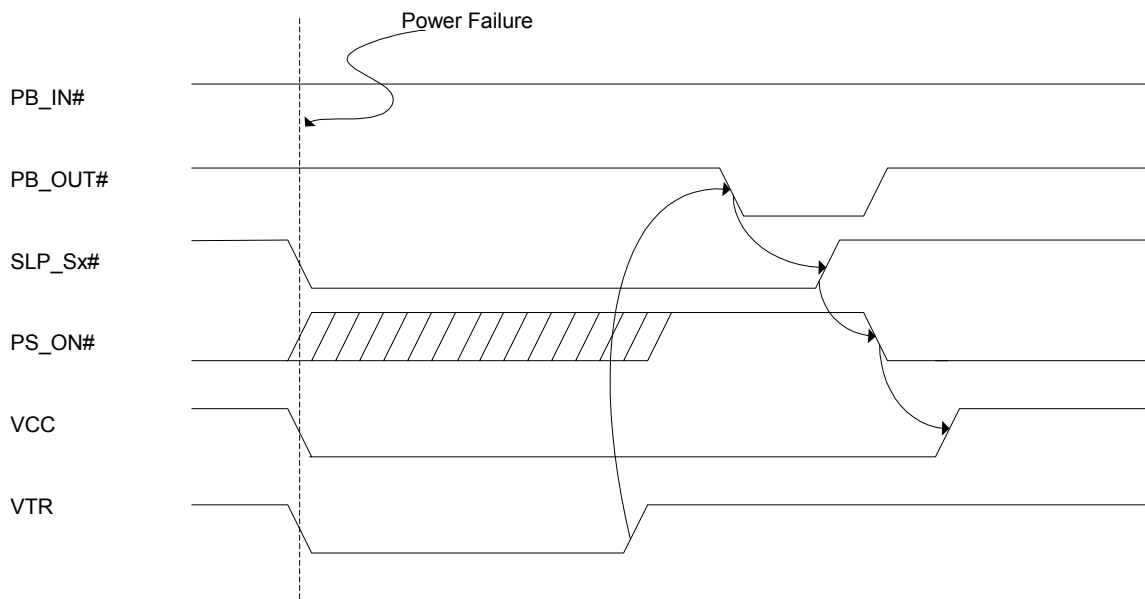

Figure 20.5 Power Supply After Power Failure (Return to On)

20.4 Resume Reset Signal Generation

nRSMRST signal is the reset output for the ICH resume well. This signal is used as a power on reset signal for the ICH.

The SCH311X detects when VTR voltage raises above PME_STS1, provides a delay before generating the rising edge of nRSMRST. See [Section 20.4, "Resume Reset Signal Generation," on page 175](#) for a detailed description of how the nRSMRST signal is generated.

20.5 Keyboard Power Button

The SCH311X has logic to detect a keyboard make/break scan codes that may be used for wakeup (PME generation). The scan codes are programmed in the Keyboard Scan Code Registers, located in the runtime register block, from offset 0x5F to 0x63 from the base address located in the primary base I/O address in Logical Device A. These registers are powered by Vbat and are reset on a Vbat POR.

The following sections will describe the format of the keyboard data, the methods that may be used to decode the make codes, and the methods that may be used to decode the break codes.

The Wake on Specific Key Code feature is enabled for the assertion of the nIO_PME signal when in SX power state or below See PME_STS1.

20.5.1 Keyboard Data Format

Data transmissions from the keyboard consist of an 11-bit serial data stream. A logic 1 is sent at an active high level. The following table shows the functions of the bits.

BIT	FUNCTION
1	Start bit (always 0)
2	Data bit 0 (least significant bit)
3	Data bit 1
4	Data bit 2
5	Data bit 3
6	Data bit 4
7	Data bit 5
8	Data bit 6
9	Data bit 7 (most significant bit)
10	Parity bit (odd parity)
11	Stop Bit (always 1)

The process to find a match for the scan code stored in the Keyboard Scan Code register meets the timing constraints as defined by the IBM Personal System/2™ Model 50 and 60 Technical Reference, dated April 1987. The timing for the keyboard clock and data signals are shown in [Chapter 29, "Timing Diagrams," on page 347](#). (See [Section 29.9, "Keyboard/Mouse Interface Timing," on page 364](#)).

20.5.1.1 Method for Receiving data is as follows:

The wake on specific key logic snoops the keyboard interface for a particular incoming scan code, which is used to wake the system through a PME event. These scan codes may be comprised of a single byte or multiple bytes. To determine when the first key code is being received, the wake on specific key logic begins sampling the data at the first falling edge of the keyboard clock for the start bit. The data is sampled on each falling edge of the clock. The hardware decodes the byte received and determines if it is valid (i.e., no parity error). Valid scan code bytes received are compared to the programmed scan code as determined by bits [3:2] SPEKEY Scan Code located in the PME_STS1 Runtime register located at offset 0x64. If the scan code(s) received matches the value(s) programmed in the Keyboard Scan Code registers then a wake on specific key status event has occurred. The wake on specific key status event is mapped to the PME and Power Button logic.

The snooping logic always checks the incoming data byte for a parity error. The hardware samples the parity bit and checks that the 8 data bits plus the parity bit always have an odd number of 1's (odd parity). If a parity error is detected the state machine used to decode the incoming scan code is reset and begins looking for the first byte in the keyboard scan code sequence.

This process is repeated until a match is found. See [Section 20.5.2, "System for Decoding Scan Code Make Bytes Received from the Keyboard," on page 177](#) and [Section 20.5.3, "System for Decoding Scan Code Break Bytes Received from the Keyboard," on page 178](#).

If the scan code received matches the programmed make code stored in the Keyboard Scan Code registers and no parity error is detected, then it is considered a match. When a match is found and if the stop bit is 1, a PME wake event (KB_PB_STS-See [Figure 20.1](#)) will be generated within 100usec of the falling edge of clock 10 of the last byte of the sequence. This wake event may be used to generate the assertion of the nIO_PME signal when in SX power state or below. PME_STS1 for description of the PME support for this PME event.

The state machine will reset and repeat the process until it is shut off by setting the SPEKEY_EN bit in the PME_STS1 register to '1'.

Datasheet

The SPEKEY_EN bit at bit 1 of the PME_STS1 register at 0xF0 in Logical Device A is used to control the “wake-on-specific feature. This bit is used to turn the logic for this feature on and off. It will disable the 32kHz clock input to the logic. The logic will draw no power when disabled. The bit is defined as follows:

0= “Wake on specific key” logic is on (default)

1= “Wake on specific key” logic is off

The state machine used to snoop the incoming data from the keyboard is synchronized by the clock high and low time. If the KCLK signal remains high or low for a nominal 125usec during the transmission of a byte, a timeout event is generated causing the snooping and scan code decoding logic to be reset, such that it will look for the first byte of the make or break scan code.

20.5.1.2 Description Of SCAN 1 and SCAN 2**SCAN 1:**

Many standard keyboards (PC/XT, MFII, etc.) generate scan 1 make and break codes per key press. These codes may be generated as a single byte or multi-byte sequences. If a single byte is generated, the make code, which is used to indicate when a key is pressed, is a value between 0h and 7Fh. The break code, which is used to indicate when a key is released, is equal to the make code plus 80h (i.e. $80h \leq \text{Break Code} \leq \text{FFh}$). If a multi-byte sequence is sent it will send E0h before the make or break.

Example of Single Byte Scan 1: Make Code = 37h, Break Code=B7h

Example of Multi-byte Scan 1: Make Code = E0h 37h, Break Code = E0h B7h.

SCAN 2:

The scan 2 make and break codes used in AT and PS/2 keyboards, which are defined by the PC 8042 Keyboard Controller, use the same scan code when a key is pressed and when the key is released. A reserved release code, 0xF0, is sent by the keyboard immediately before the key specific portion of the scan code to indicate when that the key is released.

Example of Single Byte Scan 2: Make Code = 37h, Break Code=F0h 37h

Example of Multi-byte Scan 2: Make Code = E0h 37h, Break Code = E0h F0h 37h.

20.5.2 System for Decoding Scan Code Make Bytes Received from the Keyboard

Bit [3:2] of the SPEKEY Scan Code, located in PME_STS1 register, is used to determine if the hardware is required to detect a single byte make code or a multi-byte make code. [Table 20.4](#) summarizes how single byte and multi-byte scan codes are decoded.

Keyboard Scan Code - Make Byte 1
37h

Figure 20.6 Sample Single-Byte Make Code

MSB	LSB
Keyboard Scan Code - Make Byte 1	Keyboard Scan Code - Make Byte 2
E0h	37h

Figure 20.7 Sample Multi-Byte Make Code

Note: In multi-byte scan codes the most significant byte (MSB) will be received first.

Table 20.4 Decoding Keyboard Scan Code for Make Code

SPEKEY SCAN CODE		NUMBER OF BYTES IN MAKE CODE	DESCRIPTION
Bit[3]	Bit[2]		
X	0	1 byte	<p>The wake on specific key logic will compare each valid data byte received with the Keyboard Scan Code – Make Byte 1 located in the Runtime Register block at offset 5Fh. If the data byte received matches the value stored in the register, a wake on specific key status event will be generated. This wake event may be used to generate the assertion of the nIO_PME signal. PME_STS1.</p> <p>Note: If the value programmed in Keyboard Scan Code – Make Byte 1 is 00h it is treated as a don't care and any valid scan code being compared to this byte will be a match.</p>
X	1	2 byte	<p>The wake on specific key logic compares each valid data byte received with the value programmed in the Keyboard Scan Code – Make Byte 1 located in the Runtime Register block at offset 5Fh. If the data byte received matches the value stored in the register, the hardware compares the next byte received with the value programmed in the Keyboard Scan Code – Make Byte 2 located in the Runtime Register block at offset 60h. If the consecutive bytes received match the programmed values, a wake on specific key status event is generated. If the values do not match, if a parity error occurs, or if a timeout occurs, the state machine is reset and the process is repeated. If a specific key status event is generated then it may be used to generate the assertion of the nIO_PME signal. PME_STS1.</p> <p>Note: If the value programmed in Keyboard Scan Code – Make Byte 1 or Keyboard Scan Code -Make Byte2 is 00h it is treated as a don't care and any valid scan code being compared to this byte will be a match.</p>

Notes:

- X' represents a don't care.
- By default, any time the KCLK signal is high or low for a nominal 125usec during the transmission of a byte the scan code decode cycle will be reset and the next byte received will be treated as the first byte received in the scan code byte sequence.

Once a valid make code is detected the wake on specific key logic will generate a KB_PB_STS wake event (see [Figure 20.1](#)). This wake event may be used to generate the assertion of the nIO_PME signal when in SX power state or below. PME_STS1 for description of the PME support for this PME event

20.5.3 System for Decoding Scan Code Break Bytes Received from the Keyboard

To accommodate different keyboards, there are three options for determining when the wake on specific key logic deasserts the KB_PB_STS wake event (See in [Figure 20.1](#)) going to the sticky bits in PME_STS1 and PME_STS1. Deassertion of the KB_PB_STS internally does not deassert the PME status bit.

The Keyboard Power Button Release bits (Bits [4:5]) in PME_STS1 register may select these KB_PB_STS options. See [Chapter 26, "Runtime Register," on page 293](#). A detailed description of each option is shown below.

Datasheet**Option 1 (00): De-assert KB_PB_STS 0.5sec after it is asserted.**

This option allows the user to program any scan code into the Keyboard Scan Code – Make Byte Register(s). When a valid scan code is received that matches the value programmed in the Keyboard Scan Code Register(s), a 0.5sec pulse is generated on the KB_PB_STS wake event. Regardless of the state of the SPEKEY bits in PME_STS1 and PME_STS1, no additional wake events will occur for 0.5sec.

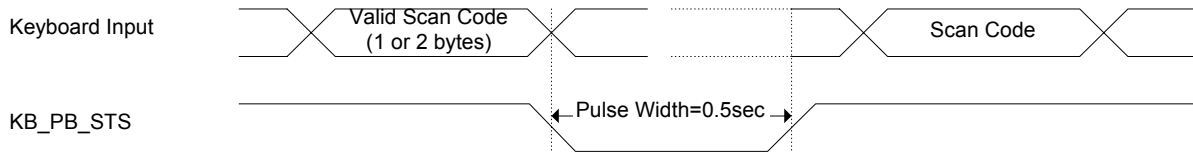
**Figure 20.8 Option 1: KB_PB_STS wake event fixed pulse width****Option 2 (01): De-assert KB_PB_STS after Scan Code Not Equal Programmed Make Code**

This option may be used by keyboards that emit single byte or multi-byte make codes for each key pressed. When a valid Scan Code is received that matches the value programmed in the Keyboard Scan Code – Make Byte Register(s), the KB_PB_STS wake event signal will be held asserted low until another valid Scan Code is received that is not equal to the programmed make code. Regardless of the state of the SPEKEY bits in PME_STS1 and PME_STS1, no additional wake events will occur until another valid Scan Code is received that is not equal to the programmed make code.

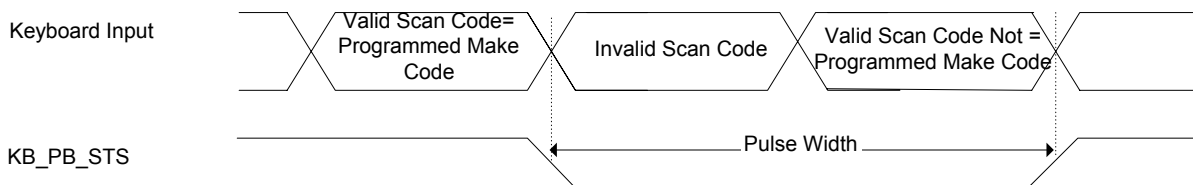
**Figure 20.9 Option 2: Assert KB_PB_STS wake event until scan code not programmed make code****Notes:**

- The Valid Scan Code may be 1 or 2 bytes depending on the SPEKEY ScanCode bits located in the PME_STS1 Runtime register at offset 64h.
- A Valid Scan Code for single byte codes means that no parity error exists. A Valid Scan Code for Multi-byte Scan Codes requires that no parity error exists and that the first Byte received matches the value programmed in the Keyboard Scan Code – Make Byte 1 located in the Runtime Register block at offset 5Fh. This value is typically E0h for Scan 1 and Scan 2 type keyboards. (Example: The ACPI power scan 2 make code is E0h, 37h) [Section 20.5.1.2, "Description Of SCAN 1 and SCAN 2," on page 177](#)

Option 3 (10): De-assert KB_PB_STS after Scan Code Equal Break Code

This option may be used with single byte and multi-byte scan 1 and scan 2 type keyboards. The break code can be configured for a specific break code or for any valid break code.

the KB_PB_STS wake event signal will be held asserted low until a valid break code is detected. The break code can be configured for a specific break code or for any valid break code. Regardless of the

state of the SPEKEY bits in PME_STS1 and PME_STS1, no additional wake events will occur until another until a valid break code is detected.

Note: Table 20.5 defines how the scan code will be decoded for the Break Code. Once a valid break code is detected, the keyboard power button event will be de-asserted as shown in Figure 20.10.

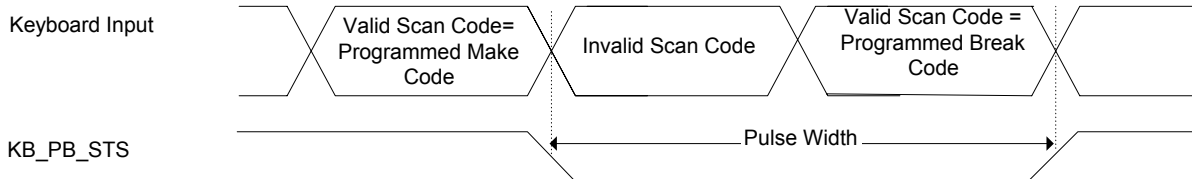

Figure 20.10 Option 3: De-assert KB_PB_STS when scan code equal break code

Note: The SPEKEY ScanCode bits are located in the PME_STS1 register Keyboard PWRBTN/SPEKEY located at offset 64h.

Table 20.5 Decoding Keyboard Scan Code for Break Code

SPEKEY SCAN CODE		SCAN CODE	NUMBER OF BYTES IN BREAK CODE	DESCRIPTION
Bit[3]	Bit[2]			
0	0	Scan 1	1 Byte	The wake on specific key logic will compare each valid data byte received with the Keyboard Scan Code – Break Byte 1 located in the Runtime Register block at offset 61h. If the data byte received matches the value stored in the register, the wake on specific key status event (KB_PB_STS) will be de-asserted. Deassertion of the KB_PB_STS internally does not deassert the PME status bit.
0	1	Scan 1	2 Bytes	The wake on specific key logic will compare each valid data byte received with the Keyboard Scan Code – Break Byte 1 located in the Runtime Register block at offset 61h. If the data byte received matches the value stored in the register, the next byte received will be compared to Keyboard Scan Code – Break Byte 2 located in the Runtime Register block at offset 62h. If this byte is a valid scan code and it matches the value programmed, the wake on specific key status (KB_PB_STS) will be de-asserted. Deassertion of the KB_PB_STS internally does not deassert the PME status bit. If the values do not match, if a parity error occurs, or if a timeout occurs, the state machine will be reset and repeat the process.
1	0	Scan 2	2 Bytes	The wake on specific key logic will compare each valid data byte received with the Keyboard Scan Code – Break Byte 1 located in the Runtime Register block at offset 61h. If the data byte received matches the value stored in the register, the next byte received will be compared to Keyboard Scan Code – Break Byte 2 located in the Runtime Register block at offset 62h. If this byte is a valid scan code and it matches the value programmed, the wake on specific key status event (KB_PB_STS) will be de-asserted. Deassertion of the KB_PB_STS internally does not deassert the PME status bit. If the values do not match, if a parity error occurs, or if a timeout occurs, the state machine will be reset and repeat the process.

Table 20.5 Decoding Keyboard Scan Code for Break Code (continued)

SPEKEY SCAN CODE		SCAN CODE	NUMBER OF BYTES IN BREAK CODE	DESCRIPTION
Bit[3]	Bit[2]			
1	1	Scan 2	3 Bytes	The wake on specific key logic will compare each valid data byte received with the Keyboard Scan Code – Break Byte 1 located in the Runtime Register block at offset 61h. If the data byte received matches the value stored in the register, the next byte received will be compared to Keyboard Scan Code – Break Byte 2 located in the Runtime Register block at offset 62h. If the data byte received matches the value stored in the register, the next byte received will be compared to Keyboard Scan Code – Break Byte 3 located in the Runtime Register block at offset 63h. If this byte is a valid scan code and it matches the value (KB_PB_STS) will be de-asserted. Deassertion of the KB_PB_STS internally does not deassert the PME status bit. If the values do not match, if a parity error occurs, or if a timeout occurs, the state machine will be reset and repeat the process.

Note: To de-assert wake on specific key status event (KB_PB_STS) on any valid break key the register containing the LSB of the break code should be programmed to 00h. If a Keyboard Scan Code – Break Byte register is programmed to 00h then any valid scan code will be a match. The value 00h is treated as a Don't Care.

20.6 Wake on Specific Mouse Event

The device can generate SX wake events (where SX is the sleep state input) based on detection of specific Mouse button clicks on a Mouse connected to the Mouse port interface (MDAT and MCLK pins). The following specific Mouse events can be used for wake-up events:

1. Any button click (left/right/middle) or any movement
2. Any one click of left/right/middle button
3. one click of left button
4. one click of right button
5. two times click of left button
6. two times click of right button

In addition to the Idle detection logic there is Start Bit Time-out logic which detects any time MCLK stays high for more than 115-145us.



Chapter 21 Low Battery Detection Logic

The low battery detection logic monitors the battery voltage to detect if this voltage drops below 2.2V and/or 1.2V. If the device is powered by Vbat only and the battery voltage is below approximately 1.2V, a VBAT POR will occur upon a VTR POR. If the device detects the battery voltage is below approximately 2.2V while it is powered by Vbat only or VTR (VCC=0V) the LOW_BAT PME and SMI Status bits will be set upon a VCC POR. When the external diode voltage drop is taken into account, these numbers become 1.5V and 2.5V, respectively.

The LOW_BAT PME event is indicated and enabled via the PME_STS1 and PME_STS1 registers. See PME_STS1 for a description of these registers.

The LOW_BAT SMI event is indicated and enabled via the SMI_STS1 and SMI_EN1 registers. See the [Chapter 26, "Runtime Register," on page 293](#) section for a description of these registers.

The following figure illustrates external battery circuit.

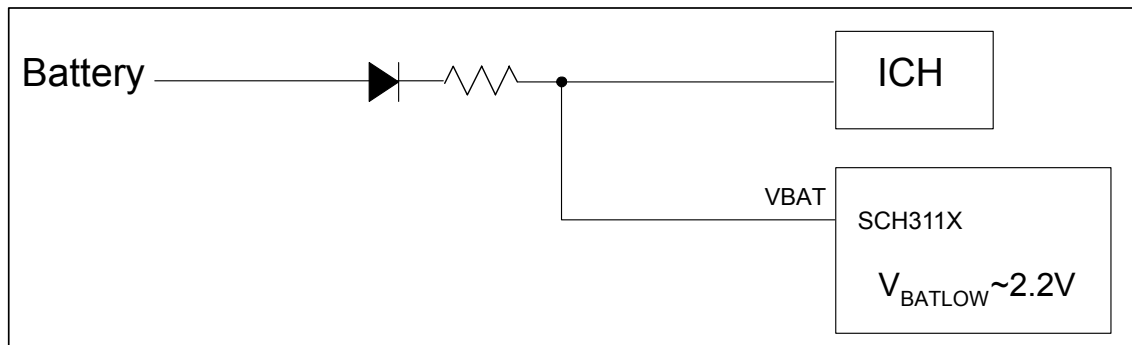

Figure 21.1 External Battery Circuit

Note that the battery voltage of 2.2V nominal is at the VBAT pin of the device, not at the source.

21.1 VBAT POR

When VBAT drops below approximately 1.2V while both VTR and VCC are off, a VBAT POR will occur upon a VTR POR.

The LOW_BAT PME and SMI Status bits is set to '1' upon a VBAT POR. Since the PME enable bit is not battery backed up and is cleared on VTR POR, the VBAT POR event is not a wakeup event. When VCC returns, if the PME or SMI enable bit (and other associated enable bits) are set, then the corresponding event will be generated.

21.2 Low Battery

21.2.1 Under Battery Power

If the battery voltage drops below approximately 2.2V under battery power (VTR and VCC off) then the LOW_BAT PME and SMI Status bits will be set upon a VCC POR. This is due to the fact that the LOW_BAT event signal is only active upon a VCC POR, and therefore the low battery event is not a wakeup event. When VCC returns, if the PME or SMI enable bit (and other associated enable bits) are set, then a corresponding event will be generated.

21.2.2 Under VTR Power

If the battery voltage drops below approximately 2.2V under VTR power (VCC off) then the LOW_BAT PME and SMI Status bits will be set upon a VCC POR. The corresponding enable bit (and other associated enable bits) must be set to generate a PME or an SMI.

If the PME enable bit (and other associated enable bits) were set prior to VCC going away, then the low battery event will generate a PME when VCC becomes active again. It will not generate a PME under VTR power and will not cause a wakeup event.

If the SMI enable bit (and other associated enable bits) were set prior to VCC going away, then the low battery event will generate an SMI when VCC becomes active again.

21.2.3 Under VCC Power

The LOW_BAT PME and SMI bits are not set when the part is under VCC power. They are only set upon a VCC POR. See the [Section 21.2.2](#).

Chapter 22 Battery Backed Security Key Register

Located at the Secondary Base I/O Address of Logical Device A is a 32 byte CMOS memory register dedicated to security key storage. This security key register is battery powered and has the option to be read protected, write protected, and lockable. The Secondary Base I/O Address is programmable at offsets 0x62 and 0x63. See PME_STS1. [Table 22.1, "Security Key Register Summary"](#) is a complete list of the Security Key registers.

Table 22.1 Security Key Register Summary

REGISTER OFFSET (HEX)	VBAT POR	REGISTER
00	0x00	Security Key Byte 0
01	0x00	Security Key Byte 1
02	0x00	Security Key Byte 2
03	0x00	Security Key Byte 3
04	0x00	Security Key Byte 4
05	0x00	Security Key Byte 5
06	0x00	Security Key Byte 6
07	0x00	Security Key Byte 7
08	0x00	Security Key Byte 8
09	0x00	Security Key Byte 9
0A	0x00	Security Key Byte 10
0B	0x00	Security Key Byte 11
0C	0x00	Security Key Byte 12
0D	0x00	Security Key Byte 13
0E	0x00	Security Key Byte 14
0F	0x00	Security Key Byte 15
10	0x00	Security Key Byte 16
11	0x00	Security Key Byte 17
12	0x00	Security Key Byte 18
13	0x00	Security Key Byte 19
14	0x00	Security Key Byte 20
15	0x00	Security Key Byte 21
16	0x00	Security Key Byte 22
17	0x00	Security Key Byte 23
18	0x00	Security Key Byte 24
19	0x00	Security Key Byte 25

Table 22.1 Security Key Register Summary (continued)

REGISTER OFFSET (HEX)	VBAT POR	REGISTER
1A	0x00	Security Key Byte 26
1B	0x00	Security Key Byte 27
1C	0x00	Security Key Byte 28
1D	0x00	Security Key Byte 29
1E	0x00	Security Key Byte 30
1F	0x00	Security Key Byte 31

Access to the Security Key register block is controlled by bits [2:1] of the Security Key Control (SKC) Register located in the Configuration Register block, Logical Device A, at offset 0xF2. The following table summarizes the function of these bits.

Table 22.2 Description of Security Key Control (SKC) Register Bits[2:1]

BIT[2] (WRITE-LOCK)	BIT[1] (READ-LOCK)	DESCRIPTION
0	0	Security Key Bytes[31:0] are read/write registers
0	1	Security Key Bytes[31:0] are Write-Only registers
1	0	Security Key Bytes[31:0] are Read-Only registers
1	1	Security Key Bytes[31:0] are not accessible. All reads/write access is denied.

Note: When Bit[1] (Read-Lock) is '1' all reads to this register block will return 00h.

- As an added layer of protection, bit [0] SKC Register Lock bit has been added to the Security Key Control Register. This lock bit is used to block write access to the Write-Lock and Read-Lock bits defined in the table above. Once this bit is set it can only be cleared by a VTR POR, VCC POR, and PCI Reset. See PME_STS1 for the definition of the Security Key Register.

Chapter 23 Temperature Monitoring and Fan Control

The Hardware Monitoring (HWM) block contains the temperature monitoring and fan control functions. The following sub-sections describe the HWM block features.

23.1 Block Diagram

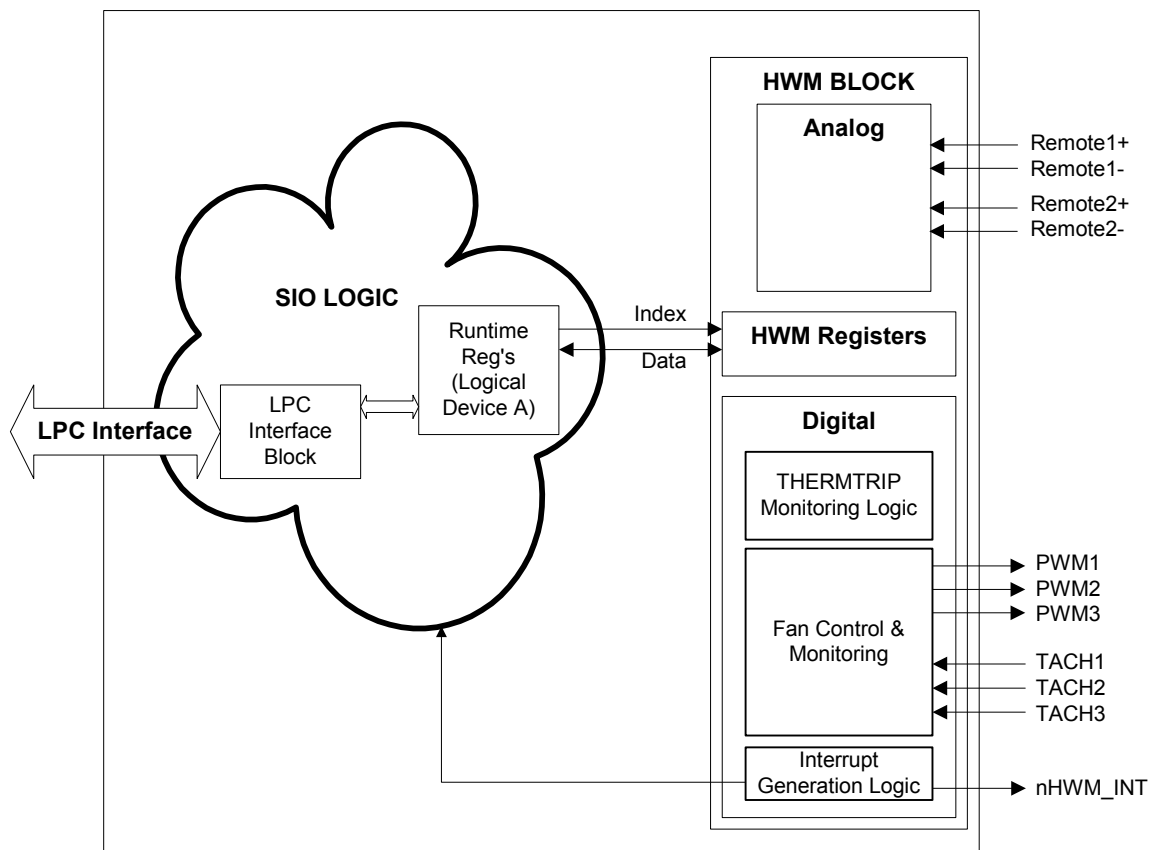

Figure 23.1 HWM Block Embedded in SCH311X

23.2 HWM Interface

The SCH311X HWM block registers are accessed through an index and data register located at offset 70h and 71h, respectively, from the the address programmed in the Base I/O Address in Logical Device A (also referred to as the Runtime Register set).

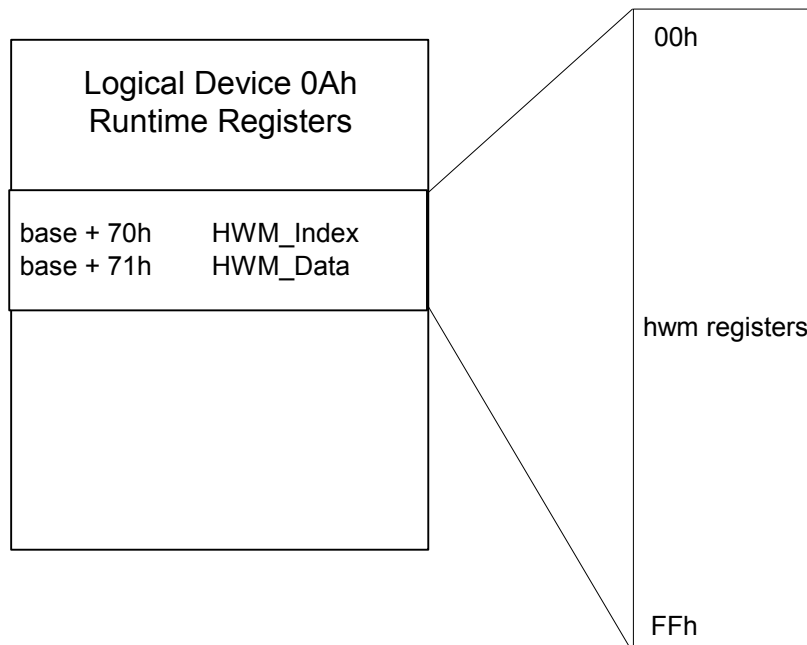

Figure 23.2 HWM Register Access

23.3 Power Supply

The HWM block is powered by standby power, HVTR, to retain the register settings during a main power (sleep) cycle. The HWM block does not operate when VCC=0 and HVTR is on. In this case, the H/W Monitoring logic will be held in reset and no monitoring or fan control will be provided. Following a VCC POR, the H/W monitoring logic will begin to operate based on programmed parameters and limits.

The fan tachometer input pins are protected against floating inputs and the PWM output pins are held low when VCC=0.

Note: The PWM pins will be forced to “spinup” (if enabled) when PWRGD_PS goes active. See “PWM Fan Speed Control” on page 200.

23.4 Resetting the SCH311X Hardware Monitor Block

23.4.1 VTR Power-On Reset

All the registers in the Hardware Monitor Block, except the reading registers, reset to a default value when VTR power is applied to the block. The default state of the register is shown in the Register Summary Table located in PME_STS1. The default state of Reading Registers are not shown because these registers have indeterminate power on values.

Note: Usually the first action after power up is to write limits into the Limit Registers.

23.4.2 VCC Power-On Reset

The PWRGD_PS signal is used by the hardware-monitoring block to determine when a VCC POR has occurred. The PWRGD_PS signal indicates that the VCC power supply is within operation range and the 14.318MHz clock source is valid.

Datasheet

Note: Throughout the description of the hardware monitoring block VCC POR and PWRGD_PS are used interchangeably, since the PWRGD_PS is used to generate a VCC POR.

All the HWM registers will retain their value through a sleep cycle unless otherwise specified. If a VCC POR is preceded by a VTR POR the registers will be reset to their default values (see PME_STS1). The following is a list of the registers and bits that are reset to their default values following a VCC POR.

- FANTACH1 LSB register at offset 28h
- FANTACH1 MSB register at offset 29h
- FANTACH2 LSB register at offset 2Ah
- FANTACH2 MSB register at offset 2Bh
- FANTACH3 LSB register at offset 2Ch
- FANTACH3 MSB register at offset 2Dh
- Bit[1] LOCK of the Ready/Lock/Start register at offset 40h
- Zone 1 Low Temp Limit at offset 67h
- Zone 2 Low Temp Limit at offset 68h
- Zone 3 Low Temp Limit at offset 69h
- Bit[3] TRDY of the Configuration register at offset 7Fh
- Top Temperature Remote diode 1 (Zone 1) register at offset AEh
- Top Temperature Remote diode 2 (Zone 3) register at offset AFh
- Top Temperature Ambient (Zone 2) register at offset B3h

23.4.3 Soft Reset (Initialization)

Setting bit 7 of the Configuration Register (7Fh) performs a soft reset on all the Hardware Monitoring registers except the reading registers. This bit is self-clearing.

23.5 Clocks

The hardware monitor logic operates on a 90kHz nominal clock frequency derived from the 14MHz clock input to the SIO block. The 14MHz clock source is also used to derive the high PWM frequencies.

23.6 Input Monitoring

The SCH311X device's monitoring function is started by writing a '1' to the START bit in the **Ready/Lock/Start** Register (0x40). Measured values from the temperature sensors are stored in Reading Registers. The values in the reading registers can be accessed via the LPC interface. These values are compared to the programmed limits in the Limit Registers. The out-of-limit and diode fault conditions are stored in the Interrupt Status Registers.

Note: All limit and parameter registers must be set before the START bit is set to '1'. Once the start bit is set, these registers become read-only.

23.7 Monitoring Modes

The Hardware Monitor Block supports two Monitoring modes: Continuous Mode and Cycle Mode. These modes are selected using bit 1 of the Special Function Register (7Ch). The following subsections contain a description of these monitoring modes.

The time to complete a conversion cycle depends upon the number of inputs in the conversion sequence to be measured and the amount of averaging per input, which is selected using the AVG[2:0] bits in the Special Function register (see the Special Function Register, 7Ch).

For each mode, there are four options for the number of measurements that are averaged for each temperature reading. These options are selected using bits[7:5] of the Special Function Register (7Ch). These bits are defined as follows:

Bits [7:5] AVG[2:0]

The AVG[2:0] bits determine the amount of averaging for each of the measurements that are performed by the hardware monitor before the reading registers are updated (). The AVG[2:0] bits are priority encoded where the most significant bit has highest priority. For example, when the AVG2 bit is asserted, 32 averages will be performed for each measurement before the reading registers are updated regardless of the state of the AVG[1:0] bits.

Table 23.1 AVG[2:0] BIT DECODER

SFTR[7:5]			MEASUREMENTS PER READING			NOMINAL TOTAL CONVERSION CYCLE TIME (MSEC)
AVG2	AVG1	AVG0	REMOTE DIODE 1	REMOTE DIODE 2	AMBIENT	
0	0	0	128	128	8	587.4
0	0	1	16	16	1	73.4
0	1	X	16	16	16	150.8
1	X	X	32	32	32	301.5

Note: The default for the AVG[2:0] bits is '010'b.

23.7.1 Continuous Monitoring Mode

In the continuous monitoring mode, the sampling and conversion process is performed continuously for each temperature reading after the Start bit is set high. The time for each temperature reading is shown above for each measurement option.

The continuous monitoring function is started by doing a write to the Ready/Lock/Start Register, setting the START bit (Bit 0) high. The part then performs a "round robin" sampling of the inputs, in the order shown below (see [Table 23.2](#)). Sampling of all values occurs in a nominal 150.8 ms (default - see [Table 23.2](#)).

Table 23.2 ADC Conversion Sequence

SAMPLING ORDER	REGISTER
1	Remote Diode Temp Reading 1
2	Ambient Temperature reading
3	Remote Diode Temp Reading 2

When the continuous monitoring function is started, it cycles through each measurement in sequence, and it continuously loops through the sequence approximately once every 150.8 ms (default - see). Each measured value is compared to values stored in the Limit registers. When the measured value violates the programmed limit the Hardware Monitor Block will set a corresponding status bit in the Interrupt Status Registers.

If auto fan option is selected, the hardware will adjust the operation of the fans accordingly.

The results of the sampling and conversions can be found in the Reading Registers and are available at any time.

Datasheet

23.7.2 Cycle Monitoring Mode

In cycle monitoring mode, the part completes all sampling and conversions, then waits approximately one second to repeat the process. It repeats the sampling and conversion process typically every 1.151 seconds (1.3 sec max - default averaging enabled). The sampling and conversion of each temperature reading is performed once every monitoring cycle. This is a power saving mode.

The cycle monitoring function is started by doing a write to the Ready/Lock/Start Register, setting the Start bit (Bit 0) high. The part then performs a “round robin” sampling of the inputs, in the order shown above.

When the cycle monitoring function is started, it cycles through each measurement in sequence, and it produces a converted temperature reading for each input. The state machine waits approximately one second before repeating this process. Each measured value is compared to values stored in the Limit registers. When the measured value violates (or is equal to) the programmed limit the Hardware Monitor Block will set a corresponding status bit in the Interrupt Status Registers.

If auto fan option is selected, the hardware will adjust the operation of the fans accordingly.

The results of each sampling and conversion can be found in the Reading Registers and are available at any time, however, they are only updated once per conversion cycle.

23.8 Interrupt Status Registers

The Hardware Monitor Block contains two primary interrupt status registers (ISRs):

- Interrupt Status Register 1 (41h)
- Interrupt Status Register 2 (42h)

There is also a secondary set of interrupt status registers:

- Interrupt Status Register 1 - Secondary (A5h)
- Interrupt Status Register 2 - Secondary (A6h)

Notes:

- The status events in the primary set of interrupt status registers is mapped to a PME bit, an SMI bit, to Serial IRQ (See [Interrupt Event on Serial IRQ on page 196](#)), and to the nHWM_INT pin.
- The nHWM_INT pin is deasserted when all of the bits in the primary ISRs (41h, 42h) are cleared. The secondary ISRs do not affect the nHWM_INT pin.
- The primary and secondary ISRs share all of the interrupt enable bits for each of the events.

These registers are used to reflect the state of all temperature and fan violation of limit error conditions and diode fault conditions that the Hardware Monitor Block monitors.

When an error occurs during the conversion cycle, its corresponding bit is set (if enabled) in its respective interrupt status register. The bit remains set until the register bit is written to ‘1’ by software, at which time the bit will be cleared to ‘0’ if the associated error event no longer violates the limit conditions or if the diode fault condition no longer exists. Writing ‘1’ to the register bit will not cause a bit to be cleared if the source of the status bit remains active.

These registers default to 0x00 on a VCC POR, VTR POR, and Initialization. (See [Resetting the SCH311X Hardware Monitor Block on page 188](#).)

See the description of the Interrupt Status registers in PME_STS1.

The following section defines the Interrupt Enable Bits that correspond to the Interrupt Status registers listed above. Setting or clearing these bits affects the operation of the Interrupt Status bits.

23.8.1 Interrupt Enable Bits

Each interrupt event can be enabled into the interrupt status registers. See the figure below for the status and enable bits used to control the interrupt bits and nHWM_INT pin. Note that a status bit will not be set if the individual enable bit is not set.

The following is a list of the Interrupt Enable registers:

- Interrupt Enable Register - Fan Tachs (80h)
- Interrupt Enable Register - Temp (82h)

Note: Clearing the individual enable bits will clear the corresponding individual status bit.

Clearing the individual enable bits. There are two cases and in both cases it is not possible to change the individual interrupt enable while the start bit is set.

1. The interrupt status bit will never be set when the individual interrupt enable is cleared. Here the interrupt status bit will not get set when the start bit is set, regardless of whether the limits are violated during a measurement.
2. If an interrupt status bit had been set from a previous condition, clearing the start bit and then clearing the individual interrupt enable bit will not clear the associated interrupts status bit immediately. It will be cleared when the start bit is set, when the associated reading register is updated.

Datasheet

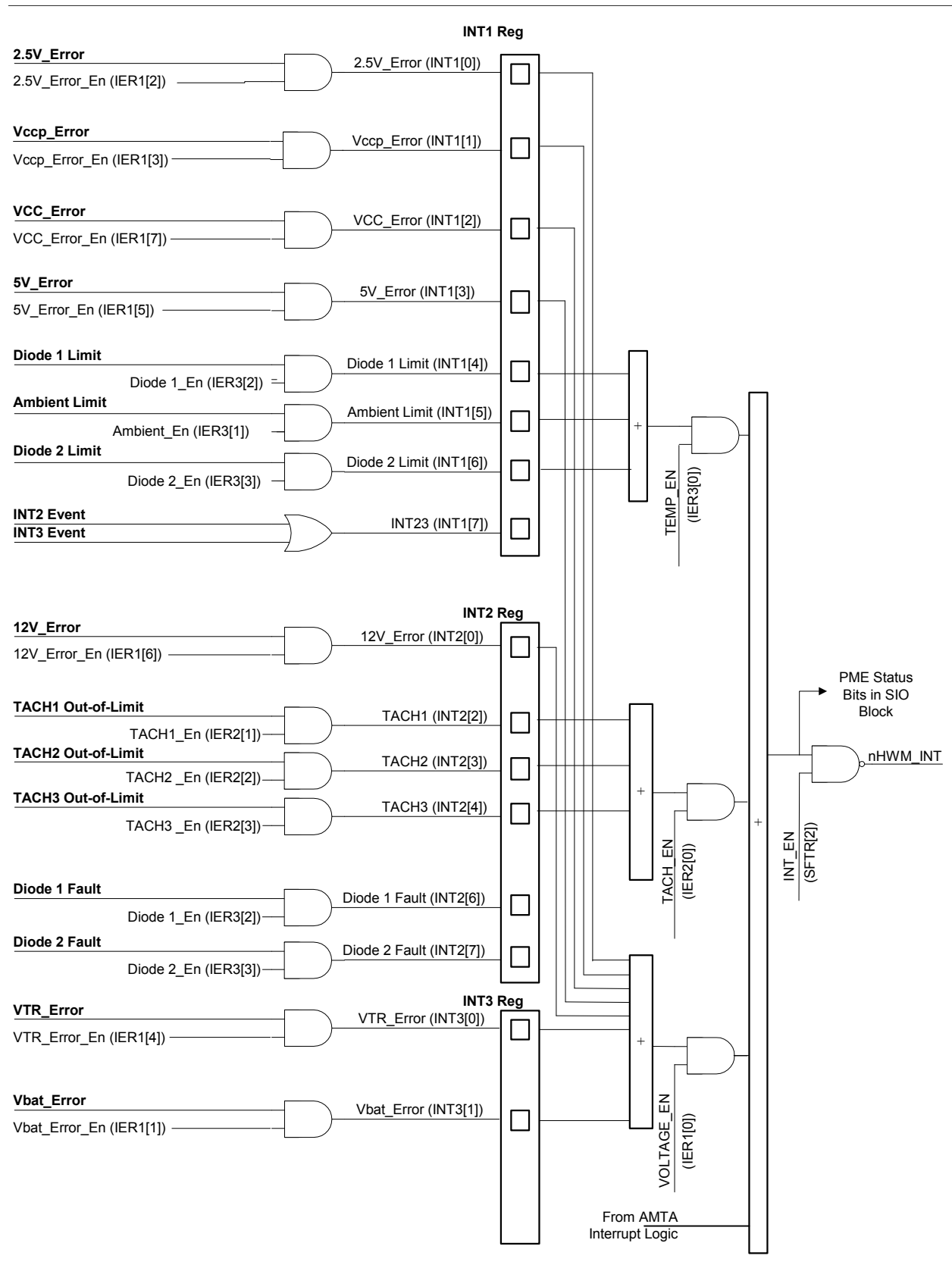

Figure 23.3 Interrupt Control

Notes:

- The Primary Interrupt Status registers, and the Top Temp Status register may be used to generate a HWM Interrupt event (HWM_Event). A HWM Interrupt Event may be used to generate a PME, SMI, Serial IRQ, or nHWM_INT event. Figure 23.3, "Interrupt Control" shows the Interrupt Status registers generating an interrupt event. To see how the Top Temp Status register generates a Top_Temp_Event see [Figure 23.9 AMTA Interrupt Mapping on page 216](#).
- The diode fault bits are not mapped directly to the nHWM_INT pin. A diode fault condition forces the diode reading register to a value of 80h, which will generate a Diode Error condition. See section [Diode Fault on page 194](#).

23.8.2 Diode Fault

The SCH311X Chip automatically sets the associated diode fault bit to 1 when any of the following conditions occur on the Remote Diode pins:

- The positive and negative terminal are an open circuit
- Positive terminal is connected to VCC
- Positive terminal is connected to ground
- Negative terminal is connected to VCC
- Negative terminal is connected to ground

The occurrence of a fault will cause 80h to be loaded into the associated reading register, except for the case when the negative terminal is connected to ground. A temperature reading of 80h will cause the corresponding diode error bit to be set. This will cause the nHWM_INT pin to become active if the individual, group (TEMP), and global enable (INTEN) bits are set.

Notes:

- The individual remote diode enable bits and the TEMP bit are located in the Interrupt Enable Register 1 (7Eh). The INTEN bit is located in bit[2] of Special Function Register (7Ch).
- When 80h is loaded into the Remote Diode Reading Register the PWM output(s) controlled by the zone associated with that diode input will be forced to full on. See [Thermal Zones on page 198](#).

If the diode is disabled, the fault bit in the interrupt status register will not be set. In this case, the occurrence of a fault will cause 00h to be loaded into the associated reading register. The limits must be programmed accordingly to prevent unwanted fan speed changes based on this temperature reading. If the diode is disabled and a fault condition does not exist on the diode pins, then the associated reading register will contain a "valid" reading (e.g. A reading that is not produced by a fault condition.).

23.9 Interrupt Signal

The hardware monitoring interrupt signal, which is used to indicate out-of-limit temperature, and/or fan errors, can be generated via a dedicated pin (nHWM_INT) or through PME Status bits or SMI Status Bits located in the Runtime Register block.

To enable temperature event and/or fan events onto the nHWM_INT pin or the PME status bits or SMI status bits, the following group enable bits must be set:

- To enable out-of-limit temperature events set bit[0] of the Interrupt Enable - Temp register (82h) to '1'.
- To enable Fan tachometer error events set bit[0] of the Interrupt Enable - Fan Tachs register (80h) to '1'.

Datasheet

23.9.1 Interrupt Pin (nHWM_INT)

The nHWM_INT function is used as an interrupt output for out-of-limit temperature and/or fan errors.

- The nHWM_INT signal is on pin 114.
- To enable the interrupt pin to go active, set bit 2 of the Special Function Register (7Ch) to '1'.

Note: If the nHWM_INT pin is not enabled the pin will be tristate if the nHWM_INT function is selected on the pin.

See [Figure 23.3 on page 193](#). The following description assumes that the interrupt enable bits for all events are set to enable the interrupt status bits to be set and no events are being masked.

If the internal or remote temperature reading violates the low or high temperature limits, nHWM_INT will be forced active low (if all the corresponding enable bits are set: individual enable bits (D1_EN, D2_EN, and/or AMB_EN), group enable bit (TEMP_EN) and the global enable bit (INTEN)). This pin will remain low while the Internal Temp Error bit or one or both of the Remote Temp Error bits in Interrupt Status 1 Register is set and the corresponding enable bit(s) are set.

The nHWM_INT pin will not become active low as a result of the remote diode fault bits becoming set. However, the occurrence of a fault will cause 80h to be loaded into the associated reading register, which will cause the corresponding diode error bit to be set. This will cause the nHWM_INT pin to become active if enabled.

The nHWM_INT pin can be enabled to indicate fan errors. Bit[0] of the Interrupt Enable 2 (Fan Tachs) register (80h) is used to enable this option. This pin will remain low while the associated fan error bit in the Interrupt Status Register 2 is set.

The nHWM_INT pin will remain low while any bit is set in any of the Interrupt Status Registers. Reading the interrupt status registers will cause the logic to attempt to clear the status bits; however, the status bits will not clear if the interrupt stimulus is still active. The interrupt enable bit (Special Function Register bit[2]) should be cleared by software before reading the interrupt status registers to insure that the nHWM_INT pin will be re-asserted while an interrupt event is active, when the INT_EN bit is written to '1' again.

The nHWM_INT pin may only become active while the monitor block is operational.

23.9.2 Interrupt as a PME Event

The hardware monitoring interrupt signal is routed to the SIO PME block. For a description of these bits see the section defining PME events. This signal is unaffected by the nHWM_INT pin enable (INT_EN) bit (See [Figure 23.3 Interrupt Control on page 193](#).)

The THERM PME status bit is located in the PME_STS1 Runtime Register at offset 04h located in the SIO block.

When a temperature or fan tachometer event causes a status bit to be set, the THERM PME status bits will be set as long as the corresponding group enable bit is set.

The enable bit is located in the PME_EN1 register at offset 0Ah.

23.9.3 Interrupt as an SMI Event

The hardware monitoring interrupt signal is routed to the SIO SMI block. For a description of these bits see the section defining SMI events. This signal is unaffected by the nHWM_INT pin enable (INT_EN) bit (See [Figure 23.3 Interrupt Control on page 193](#).)

The THERM SMI status bit is located in the SMI_STS5 Runtime Register at offset 14h located in the SIO block.

When a temperature or fan tachometer event causes a status bit to be set, the THERM SMI status bits will be set as long as the corresponding group enable bit is set.

The enable bit is located in the SMI_EN5 register at offset 1Ah.

The SMI is enabled onto the SERIRQ (IRQ2) via bit 6 of the SMI_EN2 register at 17h.

23.9.4 Interrupt Event on Serial IRQ

The hardware monitoring interrupt signal is routed to the Serial IRQ logic. This signal is unaffected by the nHWM_INT pin enable (INT_EN) bit (See [Figure 23.3 Interrupt Control on page 193.](#))

This operation is configured via the Interrupt Select register (0x70) in Logical Device A. This register allows the selection of any serial IRQ frame to be used for the HWM nHWM_INT interrupt (SERIRQ9 slot will be used). See [Interrupt Event on Serial IRQ on page 196.](#)

23.10 Low Power Mode

The hardware monitor has two modes of operation: Monitoring and Sleep. When the START bit, located in Bit[0] of the Ready/Lock/Start register (0x40), is set to zero the hardware monitor is in Sleep Mode. When this bit is set to one the hardware monitor is fully functional and monitors the analog inputs to this device.

Sleep mode is a low power mode in which bias currents are on and the internal oscillator is on, but the the A/D converter and monitoring cycle are turned off. Serial bus communication is still possible with any register in the Hardware Monitor Block while in this low-power mode.

Notes:

- In Sleep Mode the PWM Pins are held high forcing the PWM pins to 100% duty cycle (256/256).
- The START a bit cannot be modified when the LOCK bit is set.

23.11 Temperature Measurement

Temperatures are measured internally by bandgap temperature sensor and externally using two sets of diode sensor pins (for measuring two external temperatures). See subsections below.

Note: The temperature sensing circuitry for the two remote diode sensors is calibrated for a 3904 type diode.

23.11.1 Internal Temperature Measurement

Internal temperature can be measured by bandgap temperature sensor. The measurement is converted into digital format by internal ADC. This data is converted in two's complement format since both negative and positive temperature can be measured. This value is stored in Internal Temperature Reading register (26h) and compared to the Temperature Limit registers (50h – 51h). If this value violates the programmed limits in the Internal High Temperature Limit register (51h) and the Internal Low Temperature Limit register (50h) the corresponding status bit in Interrupt Status Register 1 is set.

If auto fan option is selected, the hardware will adjust the operation of the fans accordingly. See the section titled [Auto Fan Control Operating Mode on page 201.](#)

23.11.2 External Temperature Measurement

The Hardware Monitor Block also provides a way to measure two external temperatures using diode sensor pins (Remote x+ and Remote x-). The value is stored in the register (25h) for Remote1+ and Remote1- pins. The value is stored in the Remote Temperature Reading register (27h) for Remote2+ and Remote2- pins. If these values violate the programmed limits in the associated limit registers, then the corresponding Remote Diode 1 (D1) or Remote Diode 2 (D2) status bits will be set in the Interrupt Status Register 1.

Datasheet

If auto fan option is selected, the hardware will adjust the operation of the fans accordingly. See [Auto Fan Control Operating Mode on page 201](#).

There are Remote Diode (1 or 2) Fault status bits in Interrupt Status Register 2 (42h), which, when one, indicate a short or open-circuit on remote thermal diode inputs (Remote x+ and Remote x-). Before a remote diode conversion is updated, the status of the remote diode is checked. In the case of a short or open-circuit on the remote thermal diode inputs, the value in the corresponding reading register will be forced to 80h. Note that this will cause the associated remote diode limit exceeded status bit to be set (i.e. Remote Diode x Limit Error bits (D1 and D2) are located in the Interrupt Status 1 Register at register address 41h).

The temperature change is computed by measuring the change in V_{be} at two different operating points of the diode to which the Remote x+ and Remote x- pins are connected. But accuracy of the measurement also depends on non-ideality factor of the process the diode is manufactured on.

23.11.3 Temperature Data Format

Temperature data can be read from the three temperature registers:

- Internal Temp Reading register (26h)
- Remote Diode 1 Temp Reading register (25h)
- Remote Diode 2 Temp Reading register (27h)

The following table shows several examples of the format of the temperature digital data, represented by an 8-bit, two's complement word with an LSB equal to 1.0 °C.

Table 23.3 Temperature Data Format

TEMPERATURE	READING (DEC)	READING (HEX)	DIGITAL OUTPUT
-127 ⁰ C	-127	81h	1000 0001
⋮	⋮	⋮	⋮
-50 ⁰ C	-50	CEh	1100 1110
⋮	⋮	⋮	⋮
-25 ⁰ C	-25	E7h	1110 0111
⋮	⋮	⋮	⋮
-1 ⁰ C	-1	FFh	1111 1111
0 ⁰ C	0	00h	0000 0000
+1 ⁰ C	1	01h	0000 0001
⋮	⋮	⋮	⋮
+25 ⁰ C	25	19h	0001 1001
⋮	⋮	⋮	⋮
+50 ⁰ C	50	32h	0011 0010
⋮	⋮	⋮	⋮
+127 ⁰ C	127	7Fh	0111 1111
SENSOR ERROR	128	80h	1000 0000

23.11.4 Offset Registers

There are three offset registers:

- Offset Register Ambient (1Dh)
- Offset Register 2 (1Eh)
- Offset Register 1 (1Fh)

Offset Register 1 is used for Remote Diode 1 Temp Reading. Offset Register 2 is used for Remote Diode 2 Temp Reading. Offset Register Ambient is used for internal Temp Reading.

The Offset Registers contain a 2's complement value which is added (or subtracted if the number is negative) to the corresponding temperature reading. The default value in the offset register is zero, so initially zero is always added to the temperature reading.

23.12 Thermal Zones

Each temperature measurement input is assigned to a Thermal Zone to control the PWM outputs in Auto Fan Control mode. These zone assignments are as follows:

- Zone 1 = Remote Diode 1 (Processor)
- Zone 2 = Ambient Temperature Sensor
- Zone 3 = Remote Diode 2

The auto fan control logic uses the zone temperature reading to control the duty cycle of the PWM outputs.

The following sections describe the various fan control and monitoring modes in the part.

23.13 Fan Control

This Fan Control device is capable of driving multiple DC fans via three PWM outputs and monitoring up to three fans equipped with tachometer outputs in either Manual Fan Control mode or in Auto Fan Control mode. The three fan control outputs (PWMx pins) are controlled by a Pulse Width Modulation (PWM) scheme. The three pins dedicated to monitoring the operation of each fan are the FANTACH[1:3] pins. Fans equipped with Fan Tachometer outputs may be connected to these pins to monitor the speed of the fan.

23.13.1 Limit and Configuration Registers

At power up, all the registers are reset to their default values and PWM[1:3] are set to "Fan always on Full" mode. Before initiating the monitoring cycle for either manual or auto mode, the values in the limit and configuration registers should be set.

The limit and configuration registers are:

- Registers 54h – 5Bh: TACHx Minimum
- Registers 5Fh – 61h: Zone x Range/FANx Frequency
- Registers 5Ch – 5Eh: PWMx Configuration
- Registers 62h – 63h: Min/Off, PWM x Ramp Rate Control
- Registers 64h – 66h: PWMx Minimum Duty Cycle
- Registers 67h – 69h: Zone x Low Temp LIMIT
- Registers 6Ah – 6Ch: Zone x Temp Absolute Limit – all fans in Auto Mode are set to full
- Registers 6Dh – 6Eh: Zone x Hysteresis
- Register 81h: TACH_PWM Association

Datasheet

- Registers 90h – 92h: Tachx Option Registers
- Registers 94h – 96h: PWMx Option Registers

The limit and configuration registers are defined in PME_STS1.

Notes:

- The START bit in Register 40h Ready/Lock/Start Register must be set to '1' to start temperature monitoring functions.
- Setting the PWM Configuration register to Auto Mode will not take effect until after the START bit is set

23.13.2 Device Set-Up

BIOS will follow the steps listed below to configure the fan registers on this device. The registers corresponding to each function are listed. All steps may not be necessary if default values are acceptable. Regardless of all changes made by the BIOS to the limit and parameter registers during configuration, the SCH311X will continue to operate based on default values until the Start bit, in the Ready/Lock/Start register, is set. Once the Start bit is set, the SCH311X will operate according to the values that were set by BIOS in the limit and parameter registers.

Following a VTR Power-on-Reset (loss of a/c power) the following steps must be taken:

1. Set limits and parameters (not necessarily in this order)
 - a. [5F-61h] Set PWM frequencies and Auto Fan Control Range.
 - b. [62-63h] Set Ramp Rate Control and min/off
 - c. [5C-5Eh] Set the fan spin-up delays.
 - d. [5C-5Eh] Match each PWM output with a corresponding thermal zone.
 - e. [67-69h] Set the zone temperature low limits.
 - f. [6A-6Ch] Set the zone temperature absolute limits.
 - g. [64-66h] Set the PWM minimum duty cycle.
 - h. [6D-6Eh] Set the zone temperature Hysteresis values.
 - i. [81h] Associate a Tachometer input to a PWM output Register
 - j. [90-92h] Select the TACH Mode of operation (Mode 1 or Mode 2)
 - k. [90-92h] Set the number of edges per tach reading
 - l. [90-92h] Set the ignore first 3 edges of tach input bit
 - m. [90-92h] Set the SLOW bit if tach reading should indicated slow fan event as FFFEh and stalled fan event as FFFFh.
 - n. [94-96h] Set the TACH Reading Update rate
 - o. [94-96h] Set the tach reading guard time (Mode 2 Only)
 - p. [94-96h] Set the TACH reading logic for Opportunistic Mode (Mode 2 Only)
 - q. [94-96h] Set the SZEN bit, which determines if the PWM output will ramp to Off or jump to Off.
 - r. [ABh] Set the Tach 1-3 Mode
 - s. [AEh, AFh, B3h] Set the Top Temperature Remote 1, 2, Ambient
 - t. [B4h - B6h] Min Temp Adjust Temp Remote 1-2, Min Temp Adjust Temp and Delay Amb, and Min Temp Adjust Delay 1-2
 - u. [B7h] Tmin Adjust Enable
 - v. [C4h, C5h, C9h] THERMTRIP Temp Limit Remote 1, 2, Ambient
 - w. [CEh] THERMTRIP Output Enable
 - x. [D1h, D6h, DBh] PWM1, 2, 3 Max Duty Cycle
2. [40h] Set bit 0 (Start) to start monitoring
3. [40h] Set bit 1 (Lock) to lock the limit and parameter registers (optional).

Following a VCC Power-On-Reset (exiting sleep mode) the following steps must be taken. These steps are required for most systems in order to prevent improper fan start-up due to the reset of the Top Temperature and zone low limit registers to their default values on active PWRGD_PS.

1. Set the ramp rate to the min value [registers 62h and 63h].
2. Clear the start bit (bit 0 of register 40h) to stop monitoring
3. Set the Top Temperature Remote 1, 2, Ambient registers [AEh, AFh, B3h] to their initial values
4. Set the zone temperature low limit registers [67-69h] to their initial values
5. Set the start bit (bit 0 of register 40h) to start monitoring
6. Set the lock bit (bit 1 of register 40h) to lock the limit and parameter registers (optional)

Note: If not locked, the ramp rate can be set to a new value at a later time if desired [registers 62h and 63h].

23.13.3 PWM Fan Speed Control

The following description applies to PWM1, PWM2, and PWM3.

Note: The PWM output pins are held low when VCC=0. The PWM pins will be forced to “spinup” when PWRGD_PS goes active. See “Spin Up” on page 204.

The PWM pin reflects a duty cycle that is determined based on 256 PWM duty cycle intervals. The minimum duty cycle is “off”, when the pin is low, or “full on” when the pin is high for 255 intervals and low for 1 interval. The INVERT bit (bit 4 of the PWMx Configuration registers at 80h-82h) can be used to invert the PWM output, however, the default operation (following a VCC POR) of the part is based on the PWM pin active high to turn the fans “on”. When the INVERT bit is set, as long as power is not removed from the part, the inversion of the pin will apply thereafter.

When describing the operation of the PWMs, the terms “Full on” and “100% duty cycle” means that the PWM output will be high for 255 clocks and low for 1 clock (INVERT bit = 0). The exception to this is during fan spin-up when the PWM pin will be forced high for the duration of the spin-up time.

The SCH311X can control each of the PWM outputs in one of two modes:

- Manual Fan Control Operating Mode: software controls the speed of the fans by directly programming the PWM duty cycle.
- Auto Fan Control Mode: the device automatically adjusts the duty cycle of the PWM outputs based on temperature, according to programmed parameters.

These modes are described in sections that follow.

23.13.3.1 Manual Fan Control Operating Mode (Test Mode)

When operating in Manual Fan Control Operating Mode, software controls the speed of the fans by directly programming the PWM duty cycle. The operation of the fans can be monitored based on reading the temperature and tachometer reading registers and/or by polling the interrupt status registers. The SCH311X offers the option of generating an interrupt indicated by the nHWM_INT signal.

To control the PWM outputs in manual mode:

- To set the mode to operate in manual mode, write ‘111’ to bits[7:5] Zone/Mode, located in Registers 5Ch-5Eh: PWMx Configuration.
- The speed of the fan is controlled by the duty cycle set for that PWM output. The duty cycle must be programmed in Registers 30h-32h: Current PWM Duty

To monitor the fans:

Fans equipped with Tachometer outputs can be monitored via the FANTACHx input pins. See [Section 23.14.2, "Fan Speed Monitoring," on page 217.](#)

Datasheet

If an out-of-limit condition occurs, the corresponding status bit will be set in the Interrupt Status registers. Setting this status bit will generate an interrupt signal on the nHWM_INT pin (if enabled). Software must handle the interrupt condition and modify the operation of the device accordingly. Software can evaluate the operation of the Fan Control device through the Temperature and Fan Tachometer Reading registers.

When in manual mode, the current PWM duty cycle registers can be written to adjust the speed of the fans, when the start bit is set. These registers are not writable when the lock bit is set.

Note: The PWMx Current Duty Cycle register is implemented as two separate registers: a read-only and a write-only. When a value is written to this register in manual mode there will be a delay before the programmed value can be read back by software. The hardware updates the read-only PWMx Current Duty Cycle register on the beginning of a PWM cycle. If Ramp Rate Control is disabled, the delay to read back the programmed value will be from 0 seconds to $1/(2 * \text{PWM frequency})$ seconds. Typically, the delay will be $1/(2 * \text{PWM frequency})$ seconds.

23.13.3.2 Auto Fan Control Operating Mode

The SCH311X implements automatic fan control. In Auto Fan Mode, this device automatically adjusts the PWM duty cycle of the PWM outputs, according to the flow chart on the following page (see Figure 23.4 Automatic Fan Control Flow Diagram on page 202).

PWM outputs are assigned to a thermal zone based on the PWMx Configuration registers (see [Thermal Zones on page 198](#)). It is possible to have more than one PWM output assigned to a thermal zone. For example, PWM outputs 2 and 3, connected to two chassis fans, may both be controlled by thermal zone 2. At any time, if the temperature of a zone exceeds its absolute limit, all PWM outputs go to 100% duty cycle to provide maximum cooling to the system (except those fans that are disabled or in manual mode).

It is possible to have a single fan controlled by multiple zones, turning on when either zone requires cooling based on its individual settings.

If the start bit is one, the Auto Fan Control block will evaluate the temperature in the zones configured for each Fan in a round robin method. The Auto Fan Control block completely evaluates the zones for all three fans in a maximum of 0.25sec.

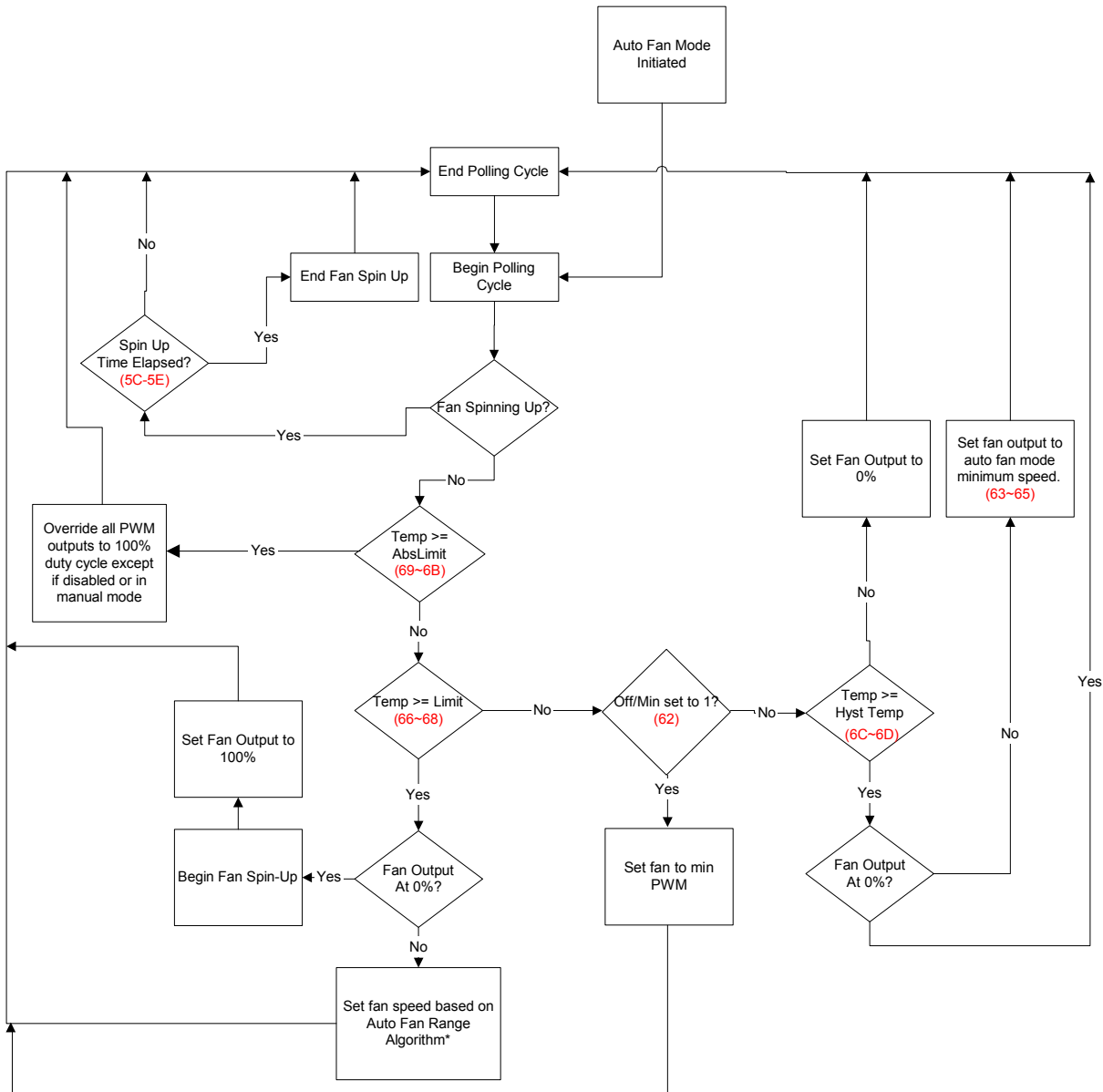
Figure 23.4 Automatic Fan Control Flow Diagram

*See PME_STS1 for details.

When in Auto Fan Control Operating Mode the hardware controls the fans directly based on monitoring of temperature and speed.

To control the fans:

1. Set the minimum temperature that will turn the fans on. This value is programmed in Registers 67h-69h: Zone x Low Temp Limit (Auto Fan Mode Only).
2. Set the hysteresis value for the minimum temperature that will turn the fans off. This value will hold the fans on until the temperature goes a certain amount below the value programmed in the Zone x Low Temp Limit registers. This value will prevent the fan from oscillating between on and off if the temperature is around the minimum temperature limit. This value is programmed in Registers 6Dh-6Eh: Zone Hysteresis registers.

Datasheet

The speed of the fan is controlled by the duty cycle set for that device. The duty cycle for the minimum fan speed must be programmed in Registers 64h-66h: PWMx Minimum Duty Cycle. This value corresponds to the speed of the fan when the temperature reading is equal to the minimum temperature LIMIT setting. As the actual temperature increases and is above the Zone LIMIT temperature and below the Absolute Temperature Limit, the PWM will be determined by a linear function based on the Auto Fan Speed Range bits in Registers 5Fh-61h.

The maximum speed of the fan for the linear autofan function is programmed in the PWMx Max registers (0D1h, 0D6h, 0DBh). When the temperature reaches the top of the linear fan function for the sensor (Zone x Low Temp Limit plus Temperature Range) the fan will be at the PWM maximum duty cycle.

Set the absolute temperature for each zone in Registers 6Ah-6Ch: Zone x Temp Absolute Limit (Auto Fan Mode only). If the actual temperature is equal to or exceeds the absolute temperature in one or more of the associated zones, all Fans operating in auto mode will be set to Full on, regardless of which zone they are operating in (except those that are disabled or configured for Manual Mode). Note: fans can be disabled via the PWMx Configuration registers and the absolute temperature safety feature can be disabled by writing 80h into the Zone x Temp Absolute Limit registers.

To set the mode to operate in auto mode, set Bits[7:5] Zone/Mode, located in Registers 5Ch-5Eh: PWM Configuration Bits[7:5]='000' for PWM on Zone 1; Bits[7:5]='001' for PWM on Zone 2; Bits[7:5]='010' for PWM on Zone 3. If the "Hottest" option is chosen (101 or 110), then the PWM output is controlled by the zone that results in the highest PWM duty cycle value.

Notes:

- Software can be alerted of an out-of-limit condition by the nHWM_INT pin if an event status bit is set and the event is enabled and the interrupt function is enabled onto the nHWM_INT pin.
- Software can monitor the operation of the Fans through the Fan Tachometer Reading registers and by the PWM x Current PWM duty registers. It can also monitor current temperature readings through the Temperature Limit Registers if hardware monitoring is enabled.
- Fan control in auto mode is implemented without any input from external processor .

In auto "Zone" mode, the speed is adjusted automatically as shown in the figure below. Fans are assigned to a zone(s). It is possible to have more than one fan assigned to a thermal zone or to have multiple zones assigned to one fan.

[Figure 23.5 on page 204](#) shows the control for the auto fan algorithm. The part allows a minimum temperature to be set, below which the fan will not run or will run at minimum speed (depending on the setting of the Min/OFF bits). A hysteresis value is included to prevent the fan continuously switching on and off if the temperature is close to the minimum. A temperature range is specified over which the part will automatically adjust the fan speed. If the fan is off and the current temperature is below the minimum temperature, then when the temperature exceeds the minimum, the fan will "spin up" by going on full for a programmable amount of time. Following this spin up time, the fan will go to a duty cycle computed by the auto fan algorithm. As the temperature rises, the duty cycle will increase until the fan is running at full-speed when the temperature reaches the minimum plus the range value. The effect of this is a temperature feedback loop, which will cause the temperature to reach equilibrium between the minimum temperature and the minimum temperature plus the range. Provided that the fan has adequate cooling capacity for all environmental and power dissipation conditions, this system will maintain the temperature within acceptable limits, while allowing the fan to run slower (and quieter) when less cooling is required.

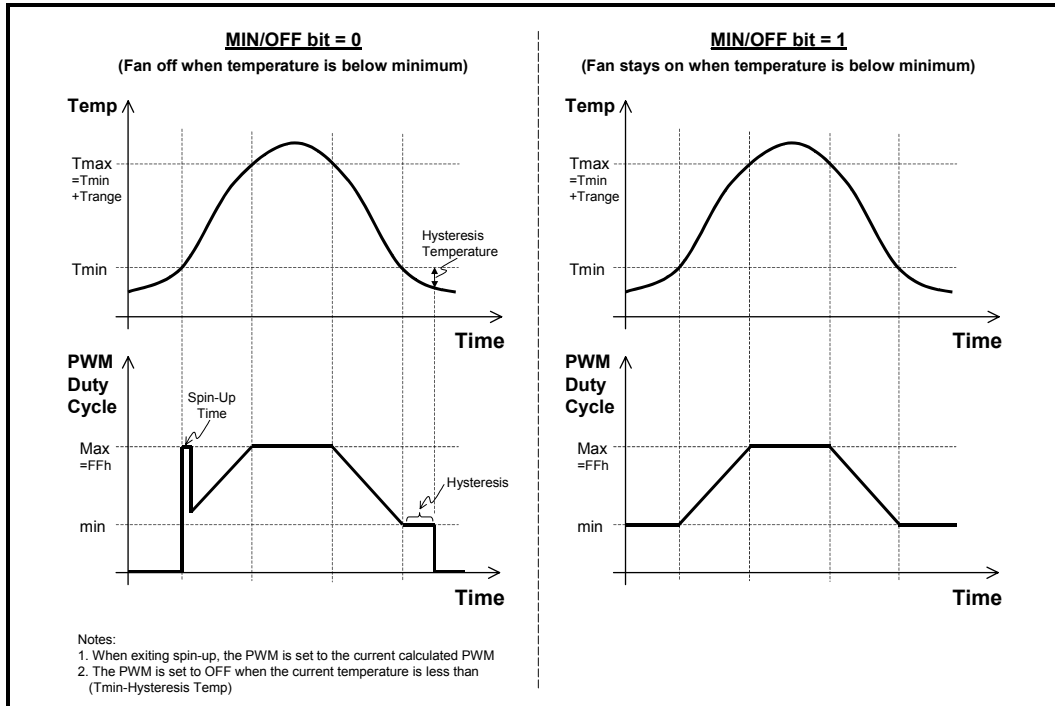

Figure 23.5 Automatic Fan Control

23.13.3.3 Spin Up

When a fan is being started from a stationary state (PWM duty cycle = 00h), the part will cause the fan to "spin up" by going to 100% duty cycle for a programmable amount of time to overcome the inertia of the fan (i.e., to get the fan turning). Following this spin up time, the fan will go to the duty cycle computed by the auto fan algorithm.

During spin-up, the PWM duty cycle is reported as 0%.

To limit the spin-up time and thereby reduce fan noise, the part uses feedback from the tachometers to determine when each fan has started spinning properly. The following tachometer feedback is included into the auto fan algorithm during spin-up.

Auto Fan operation during Spin Up:

The PWM goes to 100% duty cycle until the tachometer reading register is below the minimum limit (see [Figure 23.6](#)), or the spin-up time expires, whichever comes first. This causes spin-up to continue until the tachometer enters the valid count range, unless the spin up time expires. If the spin up expires before the tachometer enters the valid range, an interrupt status bit will be set once spin-up expires. Note that more than one tachometer may be associated with a PWM, in which case all tachometers associated with a PWM must be in the valid range for spin-up to end.

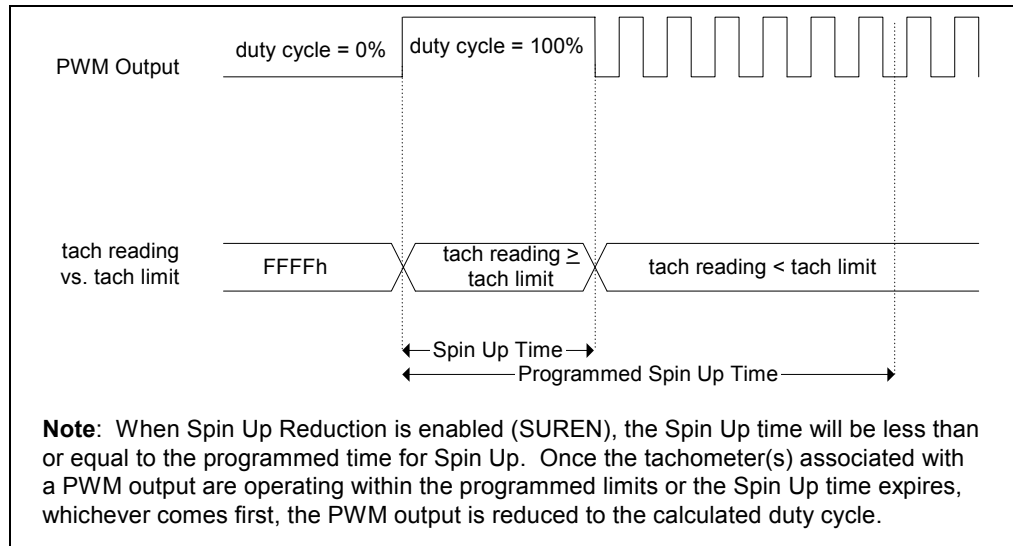

Figure 23.6 Spin Up Reduction Enabled

This feature defaults to enabled; it can be disabled by clearing bit 4 of the Configuration register (7Fh). If disabled, the all fans go to 100% duty cycle for the duration of their associated spin up time. Note that the Tachometer x minimum registers must be programmed to a value less than FFFFh in order for the spin up reduction to work properly.

Notes:

- The tachometer reading register always gives the actual reading of the tachometer input.
- No interrupt bits are set during spin-up.

23.13.3.4 Hottest Option

If the “Hottest” option is chosen (101 or 110), then the fan is controlled by the limits and parameters associated with the zone that requires the highest PWM duty cycle value, as calculated by the auto fan algorithm.

23.13.3.5 Ramp Rate Control Logic

The Ramp Rate Control Logic, if enabled, limits the amount of change in the PWM duty cycle over a specified period of time. This period of time is programmable in the Ramp Rate Control registers located at offsets 62h and 63h.

RAMP RATE CONTROL DISABLED: (DEFAULT)

The Auto Fan Control logic determines the duty cycle for a particular temperature. If PWM Ramp Rate Control is disabled, the PWM output will be set to this calculated duty cycle.

RAMP RATE CONTROL ENABLED:

If PWM Ramp Rate Control is enabled, the PWM duty cycle will Ramp up or down to the new duty cycle computed by the auto fan control logic at the programmed Ramp Rate. The PWM Ramp Rate Control logic compares the current duty cycle computed by the auto fan logic with the previous ramp rate duty cycle. If the current duty cycle is greater than the previous ramp rate duty cycle the ramp rate duty cycle is incremented by ‘1’ at the programmed ramp rate until it is greater than or equal to the current calculated duty cycle. If the current duty cycle is less than the previous ramp rate duty cycle, the ramp rate duty cycle is decremented by ‘1’ until it is less than or equal to the current duty cycle. If the current PWM duty cycle is equal to the calculated duty cycle the PWM output will remain unchanged.

Internally, the PWM Ramp Rate Control Logic will increment/decrement the internal PWM Duty cycle by '1' at a rate determined by the Ramp Rate Control Register (see). The actual duty cycle output is changed once per the period of the PWM output, which is determined by the frequency of the PWM output. (See [Figure 23.7 Illustration of PWM Ramp Rate Control on page 207.](#))

- If the period of the PWM output is less than the step size created by the PWM Ramp Rate, the PWM output will hold the duty cycle constant until the Ramp Rate logic increments/decrements the duty cycle by '1' again. For example, if the PWM frequency is 87.7Hz ($1/87.7\text{Hz} = 11.4\text{msec}$) and the PWM Step time is 206msec, the PWM duty cycle will be held constant for a minimum of 18 periods ($206/11.4 = 18.07$) until the Ramp Logic increments/decrements the actual PWM duty cycle by '1'.
- If the period of the PWM output is greater than the step size created by the PWM Ramp Rate, the ramp rate logic will force the PWM output to increment/decrement the actual duty cycle in increments larger than 1/255. For example, if the PWM frequency is 11Hz ($1/11\text{Hz} = 90.9\text{msec}$) and the PWM Step time is 5msec, the PWM duty cycle output will be incremented 18 or 19 out of 255 (i.e., $90.9/5 = 18.18$) until it reaches the calculated duty cycle. Note: The step size may be less if the calculated duty cycle minus the actual duty cycle is less than 18.

Note: The calculated PWM Duty cycle reacts immediately to a change in the temperature reading value. The temperature reading value may be updated once in TBDmsec (default) (see [Table 23.2, "ADC Conversion Sequence," on page 190.](#)) The internal PWM duty cycle generated by the Ramp Rate control logic gradually ramps up/down to the calculated duty cycle at a rate pre-determined by the value programmed in the PWM Ramp Rate Control bits . The PWM output latches the internal duty cycle generated by the Ramp Rate Control Block every $1/(\text{PWM frequency})$ seconds to determine the actual duty cycle of the PWM output pin.

PWM Output Transition from OFF to ON

When the calculated PWM Duty cycle generated by the auto fan control logic transitions from the 'OFF' state to the 'ON' state (i.e., Current PWM duty cycle > 00h), the internal PWM duty cycle in the Ramp Rate Control Logic is initialized to the calculated duty cycle without any ramp time and the PWMx Current Duty Cycle register is set to this value. The PWM output will latch the current duty cycle value in the Ramp Rate Control block to control the PWM output.

PWM Output Transition from ON to OFF

Each PWM output has a control bit to determine if the PWM output will transition immediately to the OFF state (default) or if it will gradually step down to Off at the programmed Ramp Rate. These control bits (SZEN) are located in the PWMx Options registers at offsets 94h-96h.

Table 23.4 PWM Ramp Rate

RRX- [2:0]	PWM RAMP TIME (SEC) (TIME FROM 33% DUTY CYCLE TO 100% DUTY CYCLE)	PWM RAMP TIME (SEC) (TIME FROM 0% DUTY CYCLE TO 100% DUTY CYCLE)	TIME PER PWM STEP (PWM STEP SIZE = 1/255)	PWM RAMP RATE (HZ)
000	35	52.53	206 msec	4.85
001	17.6	26.52	104 msec	9.62
010	11.8	17.595	69 msec	14.49
011	7.0	10.455	41 msec	24.39
100	4.4	6.63	26 msec	38.46
101	3.0	4.59	18 msec	55.56
110	1.6	2.55	10 msec	100

Table 23.4 PWM Ramp Rate (continued)

RRX- [2:0]	PWM RAMP TIME (SEC) (TIME FROM 33% DUTY CYCLE TO 100% DUTY CYCLE)	PWM RAMP TIME (SEC) (TIME FROM 0% DUTY CYCLE TO 100% DUTY CYCLE)	TIME PER PWM STEP (PWM STEP SIZE = 1/255)	PWM RAMP RATE (HZ)
111	0.8	1.275	5 msec	200

Example 1: PWM period < Ramp Rate Step Size

PWM frequency = 87.7Hz (11.4msec) & PWM Ramp Rate = 38.46Hz (26msec)

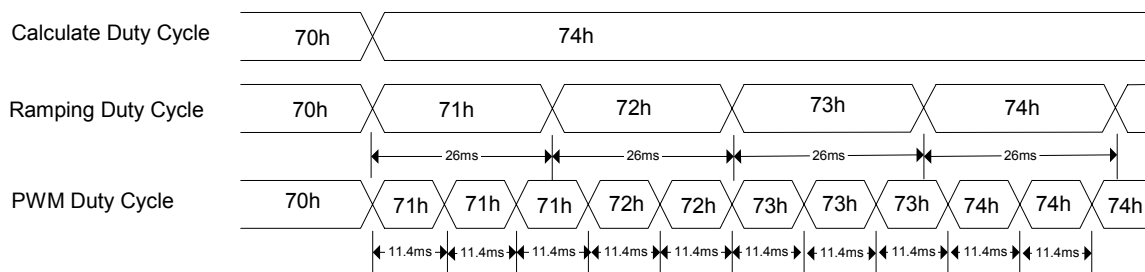
**Example 2: PWM period > Ramp Rate Step Size**

PWM frequency = 11Hz (90.9msec) & PWM Ramp Rate = 38.46Hz (26msec)

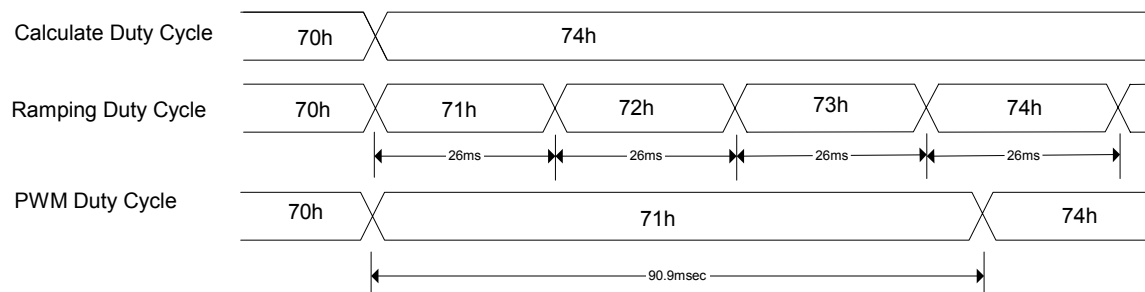
**Figure 23.7 Illustration of PWM Ramp Rate Control****Notes:**

- The PWM Duty Cycle latches the Ramping Duty Cycle on the rising edge of the PWM output.
- The calculated duty cycle, ramping duty cycle, and the PWM output duty cycle are asynchronous to each other, but are all synchronized to the internal 90kHz clock source.

It should be noted that the actual duty cycle on the pin is created by the PWM Ramp Rate Control block and latched on the rising edge of the PWM output. Therefore, the current PWM duty cycle may lag the PWM Calculated Duty Cycle.

23.13.4 Operation of PWM Pin Following a Power Cycle

This device has special features to control the level and operation of the PWM pin following a Power Cycle. These features are PWM Clamping and Forced Spinup.

23.13.4.1 PWM Clamp

The PWM pin has the option to be held low for 0 seconds or 2 seconds following a VCC POR. This feature is selectable by a Vbat powered register bit in the SIO Runtime Register block.

Bit[7] of the DBLCLICK register at offset 5Bh is used to select the 0 or 2 second option.

This bit is defined as follows:

- BIT[3] ZERO_SPINUP
 - 1=zero delay for spin up
 - 0 = delay spinup by 2 seconds (default)

Following PWRGD_PS being asserted the PWM Pin will be held low until either the TRDY signal is asserted or the delay counter expires, whichever comes first. The delay counter performs two functions when set to the 2 second delay option.

1. Following a VTR POR & VCC POR, the BIOS has up to 2 seconds to program the hwm registers and enable autofan before the fans are turned on full. This is a noise reduction feature
2. Following a VCC POR only (return from sleep) the hardware requires 150.8 ms (default - see [Table 23.2](#)) to load the temperature reading registers. The TRDY signal is used to indicate when these values have been updated. TRDY is reset to zero on a VCC POR, which forces the Fans to be set to FFh. If the delay counter is enabled for up to a 2 second delay, the PWMs will be held low until the reading registers are valid. Once the registers are updated, the hardware will initiate a forced spinup (if enabled) and enter automode. See [Forced Spinup on page 208](#).

The timing diagrams in the section titled [Timing Diagrams for PWM Clamp and Forced Spinup Operation on page 209](#) show the effect of the 2 second PWM hold-off counter on the PWM pin.

23.13.4.2 Forced Spinup

Spinup is a feature of the auto fan control mode. Any time the PWM pin transitions from a 0% duty cycle to a non zero duty cycle the PWM pin will be forced high for the duration of spinup or until the fan are spinning within normal operating parameters as determined by the Tach Limit registers. See [Spin Up on page 204](#) for a more detailed description of spinup. This feature can also be initiated by the PWRGD_PS signal transitioning high following a main (VCC) power cycle if the TRDY bit is set to one before the PWM Clamp is released.

Notes:

- In this device, a forced spinup will be generated the first time TRDY is detected as a '1' following the PWRGD_PS signal transitioning from low to high (if enabled). To enable this feature, set bit[3] of the PWMx Configuration registers to one. These registers are located at offsets 5Ch, 5Dh, and 5Eh.
- If the TRDY bit is '1' and cleared by software after being set to and then set again while the PWRGD_PS signal is high, the act of TRDY being asserted will not cause a forced spinup event.
- The duration of the forced spin-up time is controlled by the SPIN[2:0] bits located in the PWM x Configuration registers (5Ch - 5Eh). The forced spinup enable bit is located in Bit[3] SUENx of the PWMx Configuration registers. Forced Spinup defaults to disabled on a VTR POR.

START OF SPIN-UP ON MAIN (VCC) POWER CYCLE

The PWM spin-up supports the scenario where the part is powered by VTR and the fans are powered by a main power rail. If the start bit is not cleared on a main power cycle, then the PWM will remain at a level that may not start the fan when the main supply ramps up. This spinup will force each PWM into spin-up (if enabled) when the TRDY bit goes active.

START OF SPIN-UP ON STANDBY (VTR) POWER CYCLE

The two second PWM Clamping feature may be used to delay the fans from being turned on full until the BIOS has the opportunity to program the limit and configuration registers for the auto fan control

Datasheet

mode. (See [PWM Clamp on page 208](#)) This is a noise reduction feature. Once the TRDY bit goes high the clamp will be released and the fans will be forced into spinup.

Note: If the two second PWM Clamping period expires before TRDY is asserted, the PWMs will be set to Full On.

23.13.4.3 Timing Diagrams for PWM Clamp and Forced Spinup Operation

Case 1: Spinup Operation Following PWRGD_PS Active after VTR POR.
START bit and TRDY go high during 2 sec delay.

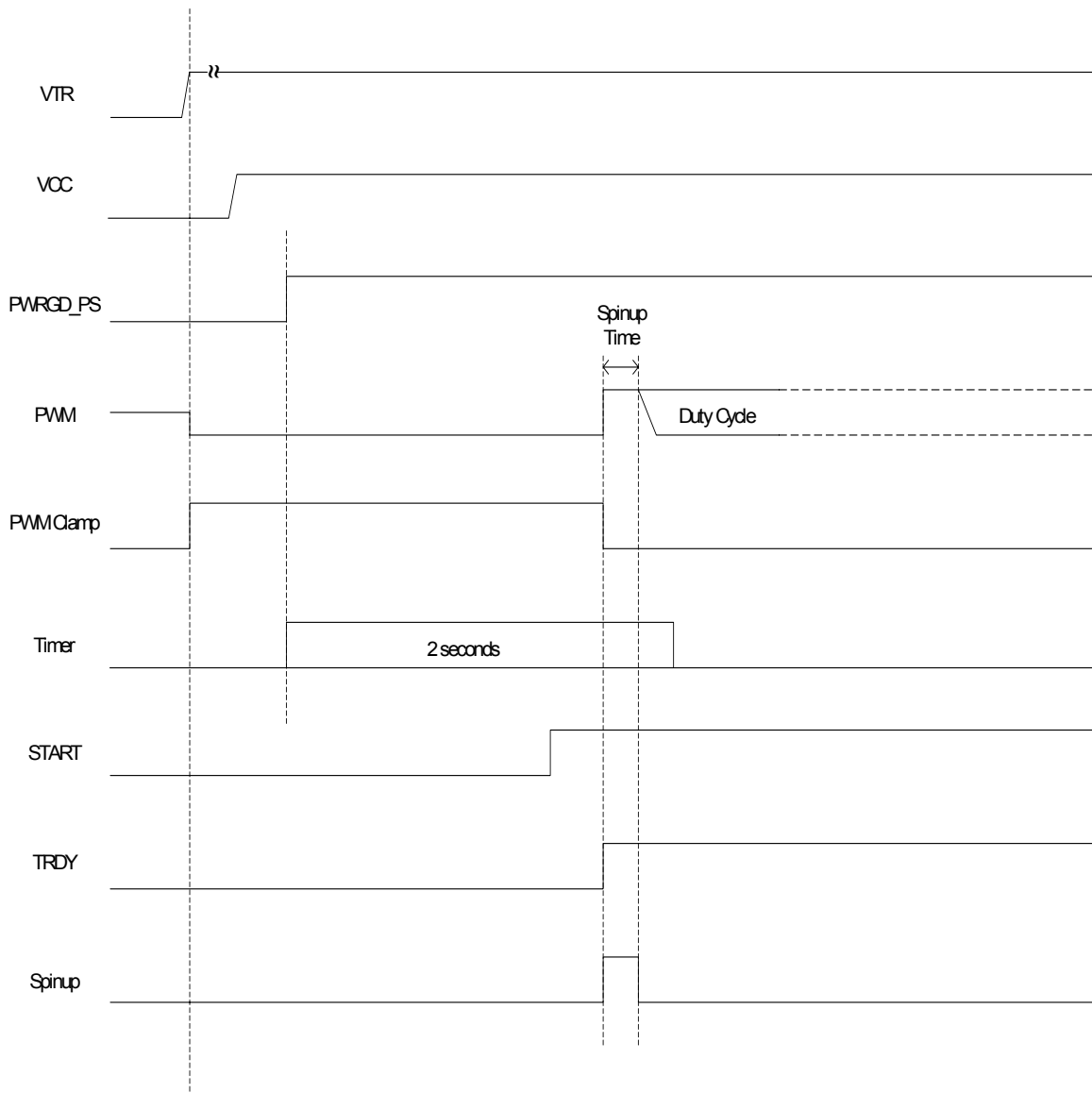

Case 2: Spinup Operation Following PWRGD_PS Active after VTR POR.
 START bit goes high during 2 sec delay, TRDY goes high after 2 sec delay.

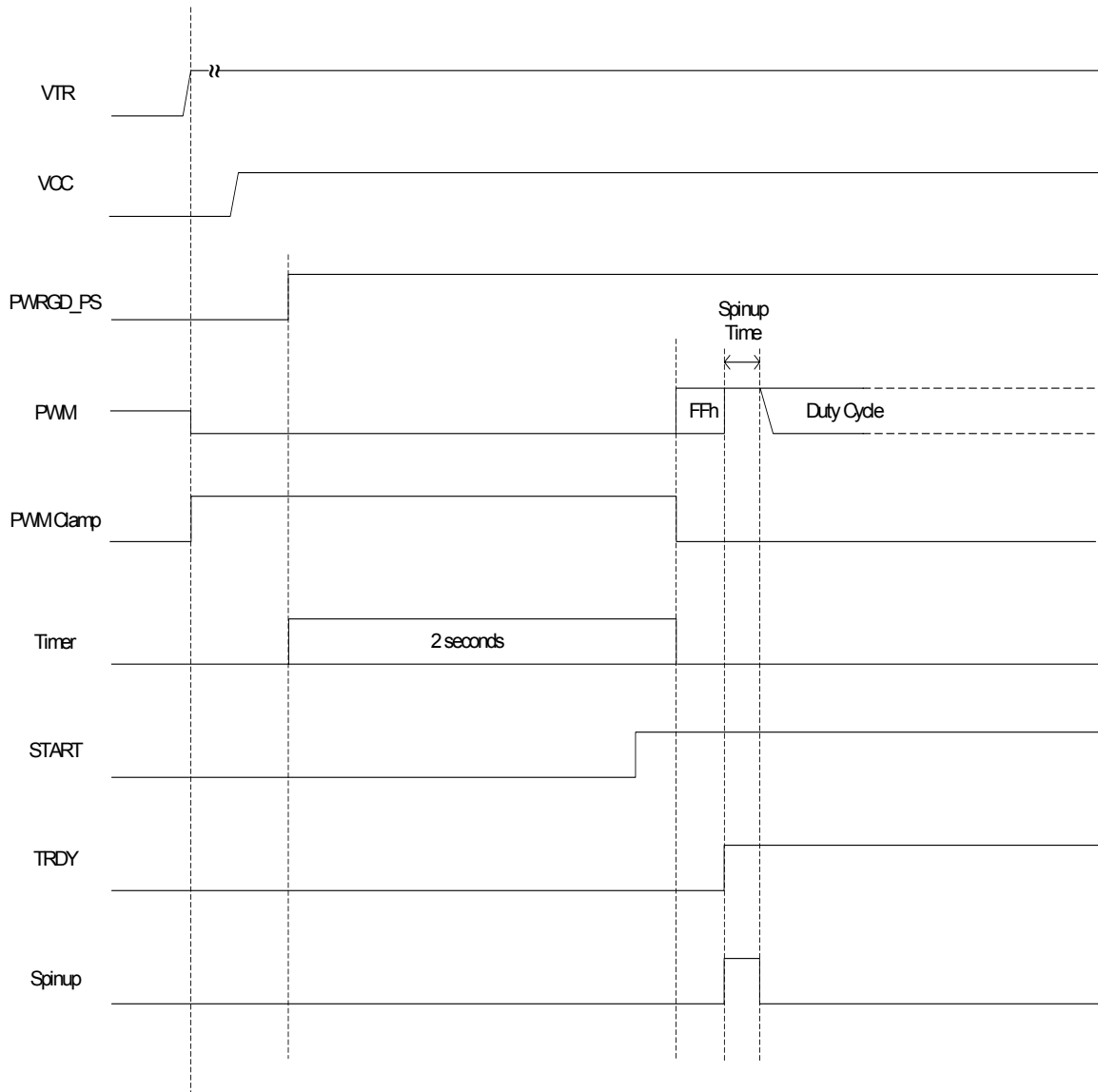

Case 3: Spinup Operation Following PWRGD_PS Active after VTR POR
 START bit and TRDY go high after 2 sec delay.

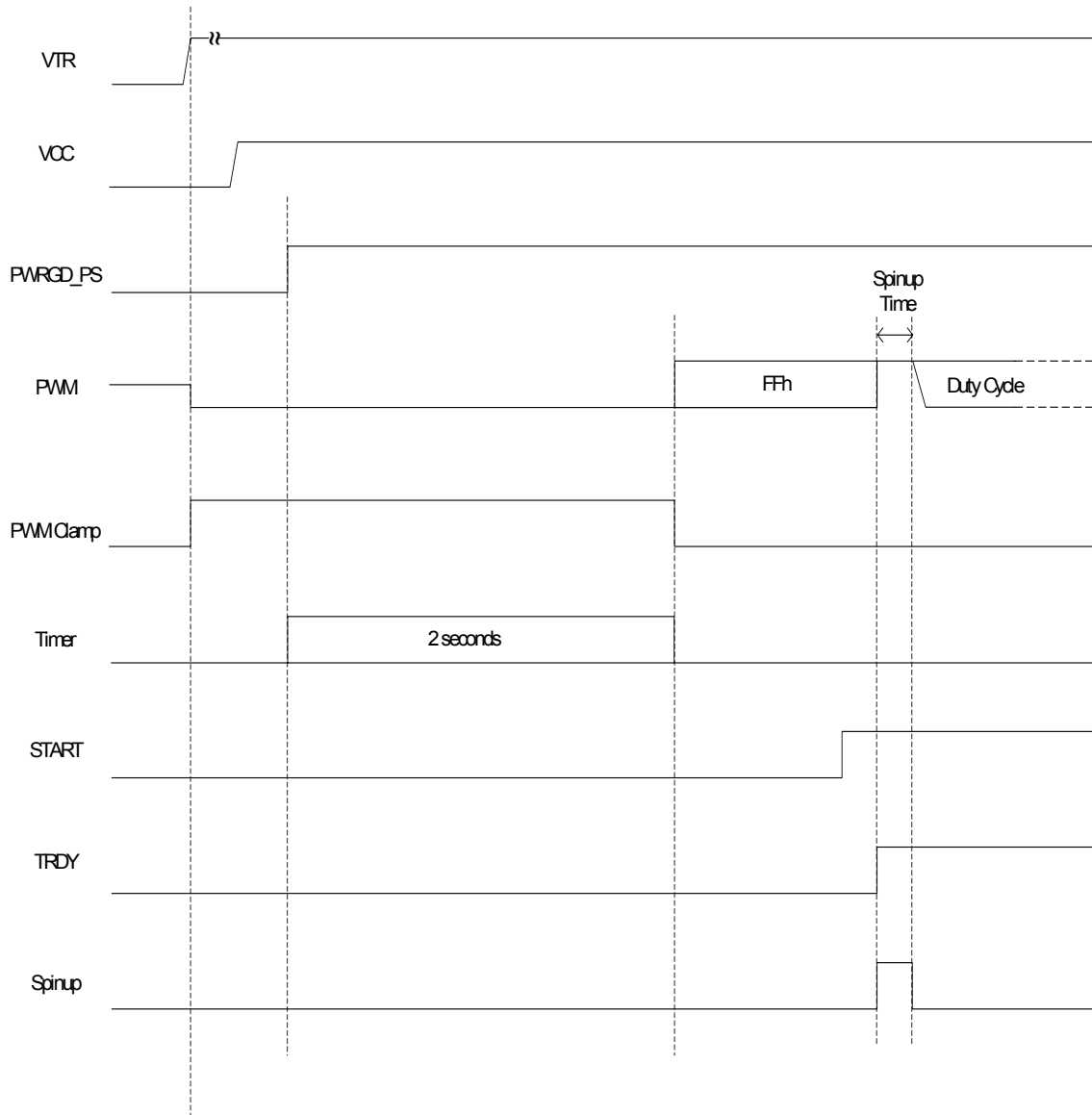

Case 4: Spinup Operation Following PWRGD_PS Active after VTR POR.
 START bit and TRDY do not go high.

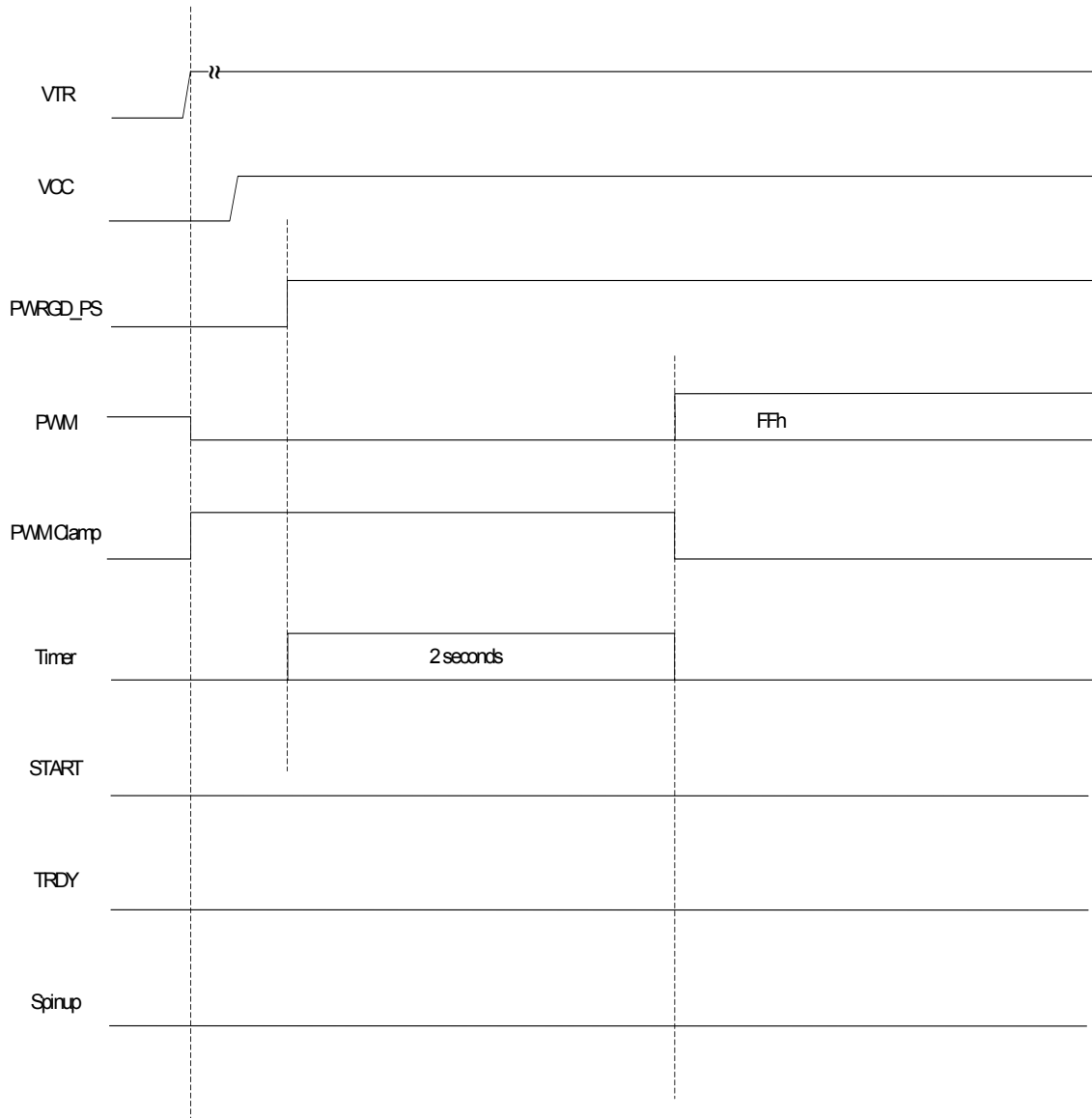

**Case 5: Spinup Operation Following PWRGD_PS Active after VCC POR.
START bit and TRDY high before 2 sec delay.**

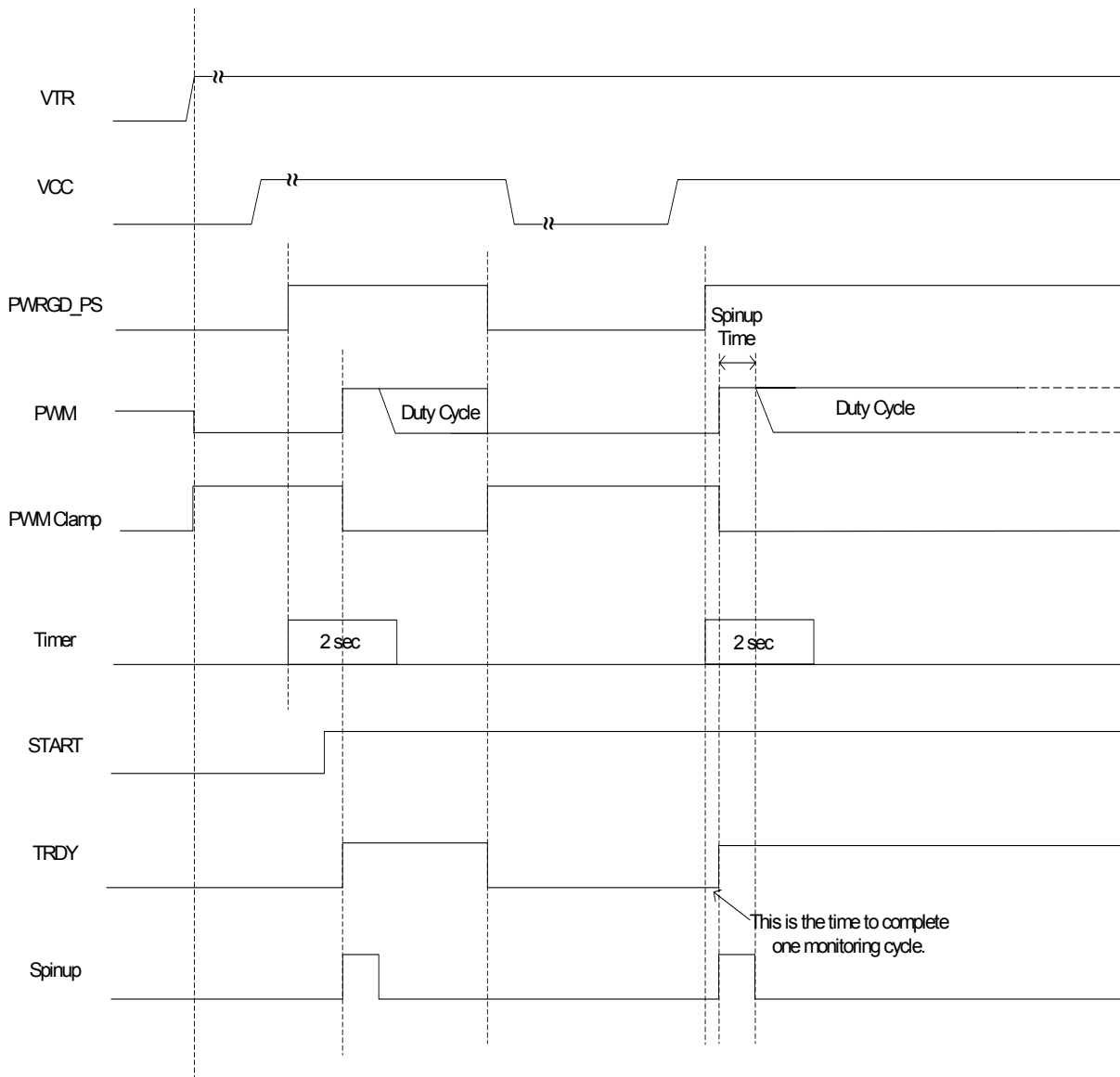

23.13.5 Active Minimum Temperature Adjustment (AMTA)

The AMTA operation in the SCH311X consists of a "Top Temperature" register (for each zone) that defines the upper bound of the operating temperature for the zone. If the temperature exceeds this value, the minimum temperature (Low Temp Limit) for the zone is adjusted down. This keeps the zone operating in the lower portion of the temperature range of the fan control function (PWM Duty Cycle vs. Temperature), thereby limiting fan noise by preventing the fan from going to the higher PWM duty cycles.

23.13.5.1 Adjusting Minimum Temperature Based on Top Temperature

This describes the option for adjusting the minimum temperature based on the Top Temperature.

The AMTA option automatically adjusts the preprogrammed value for the minimum temperature and shifts the temperature range for the autofan algorithm to better suit the environment of the system, that is, to bias the operating range of the autofan algorithm toward the low end of the temperature range.

It uses a programmed value for the “Top temperature” for the zone to shift the temperature range of the autofan algorithm, and therefore the speed of the fan, toward the middle of the fan control function (PWM Duty Cycle vs. Temperature). This feature will effectively prevent the fans from going on full, thereby limiting the noise produced by the fans.

The value of the Top temperature for each zone can be programmed to be near the center of the temperature range for the zone, or near the maximum as defined by the low temp limit plus range. The implementation of the AMTA feature is defined as follows:

This feature can be individually enabled to operate for each zone. Each zone has a separate enable bit for this feature (register 0B7h). Note that if the piecewise linear fan function is used, the minimum temperature for the zone (Zone x Low Temp Limit register) is shifted down, which will result in each segment being shifted down.

This feature adjusts the minimum temperature for each zone for the autofan algorithm based on the current temperature reading for the zone exceeding the Top temperature.

When the current temperature for the zone exceeds the Top temperature for the zone, the minimum temperature value is reloaded with the value of the minimum temperature limit minus a programmable temperature adjustment value for the zone, as programmed in the Min Temp Adjust registers. The temperature adjustment value is programmable for each zone.

The zone must exceed the limits set in the associated Top Temp Zone [3:1] register for two successive monitoring cycles in order for the minimum temperature value to be adjusted (and for the associated status bit to be set).

The new minimum temperature value is loaded into the low temp limit register for each zone (Zone x Low Temp Limit). This will cause the temperature range of the autofan algorithm to be biased down in temperature.

Note: When the minimum temperature for the zone is adjusted, the autofan algorithm will operate with a new fan control function (PWM Duty Cycle vs. Temperature), which will result in a new PWM duty cycle value. The PWM will move to the new value smoothly, so there is little audible effect when the PWM Ramp rate control is enabled.

This process will repeat after a delay until the current temperature for the zone no longer exceeds the Top temperature for the zone.

Once the minimum temp value is adjusted, it will not adjust again until after a programmable time delay. The delay is programmed for each zone in the Min Temp Adjust Delay registers. The adjust times are as follows: 1, 2, 3, and 4 minutes.

Figure 8.5 illustrates the operation of the AMTA for one adjustment down in minimum temperature resulting from the temperature exceeding the Top temperature. The effect on the linear fan control function (PWM Duty Cycle vs. Temperature) is shown.

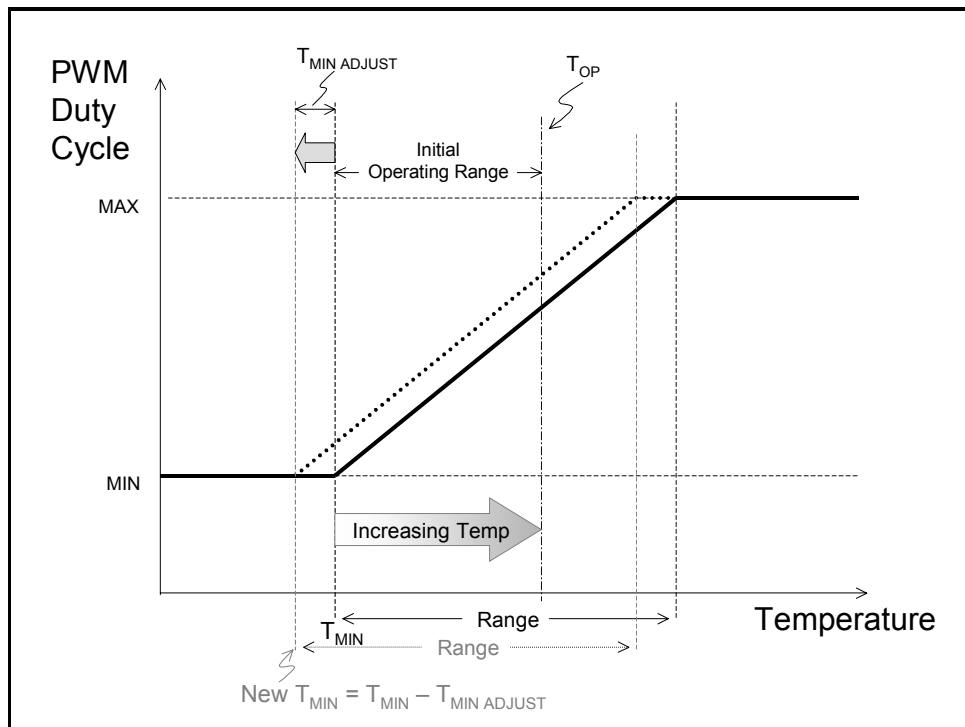

Figure 23.8 AMTA Illustration, Adjusting Minimum Temperature

Note: If the AMTA feature is not enabled for a zone, then the Top temperature register for that zone is not used.

INTERRUPT GENERATION

The following figure illustrates the operation of the interrupt mapping for the AMTA feature in relation to the status bits and enable bits.

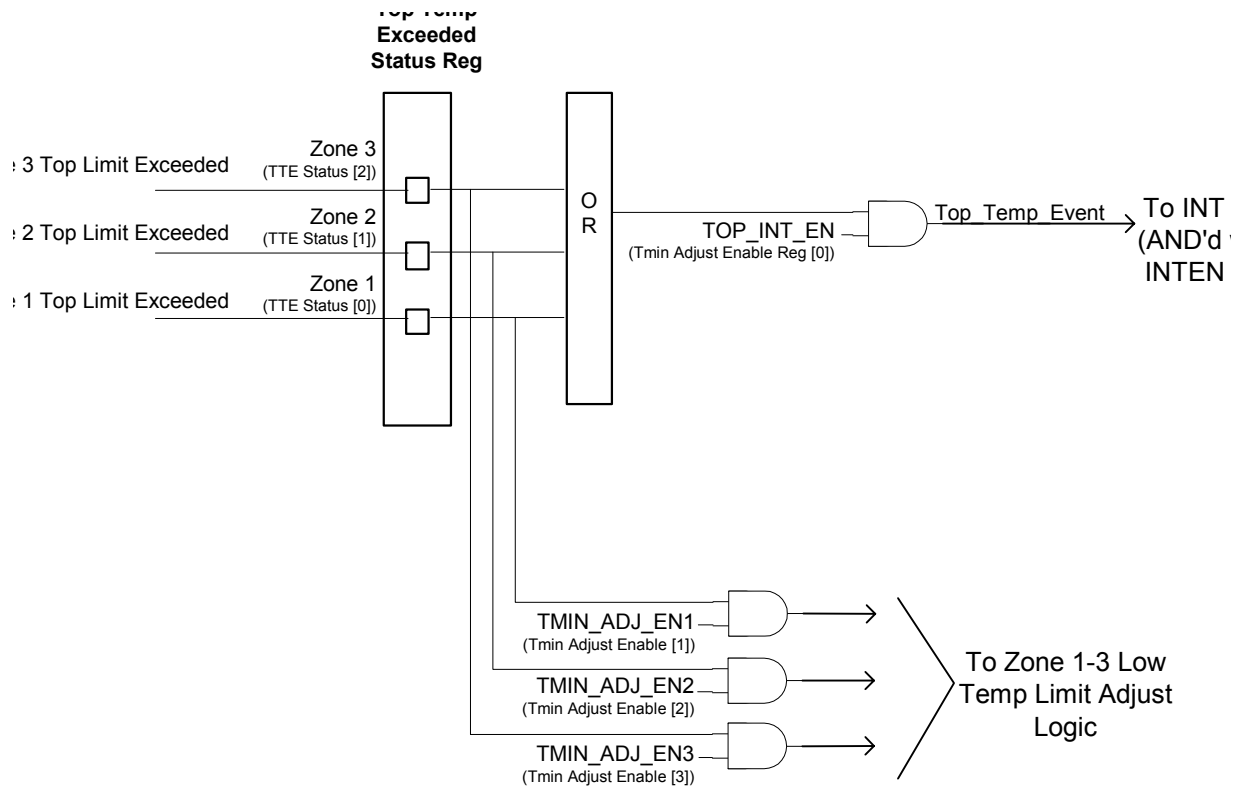

Figure 23.9 AMTA Interrupt Mapping

23.14 nTHERMTRIP

The nTHERMTRIP output pin can be configured to assert when any of the temperature sensors (remote diodes 1-2, internal) is above its associated temperature limit.

The Thermtrip Enable register at offset CEh selects which reading(s) will cause the nTHERMTRIP signal to be active, when the selected temperature(s) exceed in the associated limit registers (C4h for Remote Diode 1, C5h for Remote diode 2, and C9h for Ambient temp) their pre-programmed limit.

An internal version of this output will also be used by the RESGEN block to generate a system reset pulse. More details can be found in [Chapter 18, "Reset Generation," on page 163](#).

23.14.1 nTHERMTRIP Operation

The nTHERMTRIP pin can be configured to assert when one of the temperature zones is above its associated nTHERMTRIP temperature limit (THERMTRIP Temp Limit Zone[3:1]). The Thermtrip temperature limit is a separate limit register from the high limit used for setting the interrupt status bits for each zone.

The THERMTRIP Limit Zone[3:1] registers represent the upper temperature limit for asserting nTHERMTRIP for each zone. These registers are defined as follows: If the monitored temperature for the zone exceeds the value set in the associated THERMTRIP Temp Limit Zone[3:1], the corresponding bit in the THERMTRIP status register will be set. The nTHERMTRIP pin may or may not be set depending on the state of the associated enable bits (in the THERM Output Enable register).

Each zone may be individually enabled to assert the nTHERMTRIP pin (as an output).

Datasheet

The zone must exceed the limits set in the associated THERMTRIP Temp Limit Zone [3:1] register for two successive monitoring cycles in order for the nTHERMTRIP pin to go active (and for the associated status bit to be set).

The following figures summarize the THERMTRIP operation in relation to the THERMTRIP status bits.

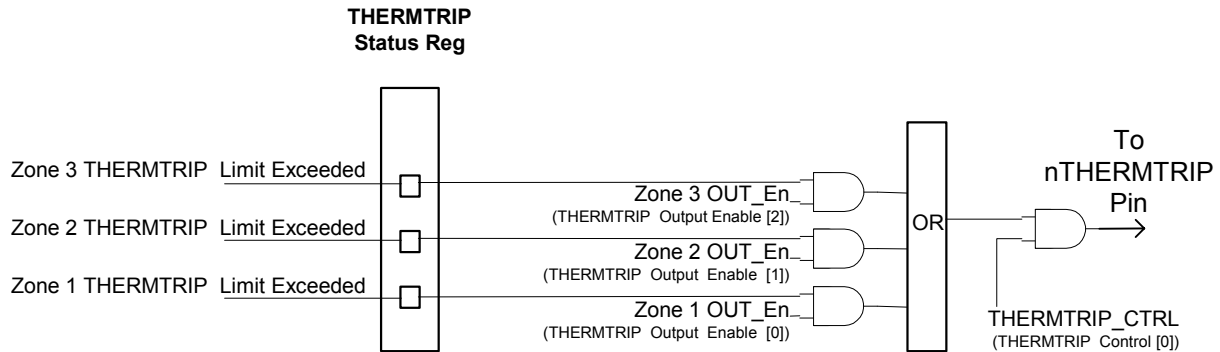

Figure 23.10 nTHERMTRIP Output Operation

23.14.2 Fan Speed Monitoring

The chip monitors the speed of the fans by utilizing fan tachometer input signals from fans equipped with tachometer outputs. The fan tachometer inputs are monitored by using the Fan Tachometer registers. These signals, as well as the Fan Tachometer registers, are described below.

The tachometers will operate in one of two modes:

- Mode 1: Standard tachometer reading mode. This mode is used when the fan is always powered when the duty cycle is greater than 00h.
- Mode 2: Enhanced tachometer reading mode. This mode is used when the PWM is pulsing the fan.

23.14.2.1 TACH Inputs

The tachometer inputs are implemented as digital input buffers with logic to filter out small glitches on the tach signal.

23.14.2.2 Selecting the Mode of Operation:

The mode is selected through the Mode Select bits located in the Tach Option register. This Mode Select bit is defined as follows:

- 0=Mode 1: Standard tachometer reading mode
- 1=Mode 2: Enhanced tachometer reading mode.

Default Mode of Operation:

- Mode 1

- Slow interrupt disabled (Don't force FFFh)
- Tach interrupt enabled via enable bit
- Tach Limit = FFFFh
- Tach readings updated once a second

23.14.2.3 Mode 1 – Always Monitoring

Mode 1 is the simple case. In this mode, the Fan is always powered when it is 'ON' and the fan tachometer output ALWAYS has a valid output. This mode is typically used if a linear DC Voltage control circuit drives the fan. In this mode, the fan tachometer simply counts the number of 90kHz pulses between the programmed number of edges (default = 5 edges). The fan tachometer reading registers are continuously updated.

The counter is used to determine the period of the Fan Tachometer input pulse. The counter starts counting on the first edge and continues counting until it detects the last edge or until it reaches FFFFh. If the programmed number of edges is detected on or before the counter reaches FFFFh, the reading register is updated with that count value. If the counter reaches FFFFh and no edges were detected a stalled fan event has occurred and the Tach Reading register will be set to FFFFh. If one or more edges are detected, but less than the programmed number of edges, a slow fan event has occurred and the Tach Reading register will be set to either FFFEh or FFFFh depending on the state of the Slow Tach bits located in the TACHx Options registers at offsets 90h - 93h. Software can easily compute the RPM value using the tachometer reading value if it knows the number of edges per revolution.

Notes:

- If the PWM output associated with a tach input is configured for the high frequency option then the tach input must be configured for Mode 1.
- Some enhanced features added to support Mode 2, are available to Mode 1 also. They are: programmable number of tach edges and force tach reading register to FFFEh to indicate a SLOW fan.
- Five edges or two tach pulses are generated per revolution.
- If a tach input is left unconnected it must be configured for Mode 1.

23.14.2.4 Mode 2 – Monitor Tach input When PWM is 'ON'

In this mode, the PWM is used to pulse the Fan motor of a 3-wire fan. 3-wire fans use the same power supply to drive the fan motor and to drive the tachometer output logic. When the PWM is 'ON' the fan generates valid tach pulses. When the PWM is not driving the Fan, the tachometer signal is not generated and the tach signal becomes indeterminate or tristate. Therefore, Mode 2 only makes tachometer measurements when the associated PWM is driving high during an update cycle. As a result, the Fan tachometer measurement is "synchronized" to the PWM output, such that it only looks for tach pulses when the PWM is 'ON'.

Note: Any fan tachometer input may be associated with any PWM output (see [Linking Fan Tachometers to PWMs on page 223.](#))

During an update cycle, if an insufficient number of tachometer pulses are detected during this time period, the following applies: If at least one edge but less than the programmed number of edges is detected, the fan is considered slow. If no edge is detected, the fan is considered stopped.

Notes:

- The interrupt status bits are set, if enabled, to indicate that a slow or stopped fan event has occurred when the tach reading registers are greater than the tach limit registers.
- At some duty cycles, the programmed number of edges will appear during some PWM High times, but not all. If opportunistic mode is enabled, the tach logic will latch the count value any time it detects the programmed number of edges and reset the update counter. (See Bit[5] of PME_STS1.)

Datasheet

An interrupt will only be generated if no valid readings were made during the programmed update time.

ASSUMPTIONS (REFER TO FIGURE 4 - PWM AND TACHOMETER CONCEPT):

The Tachometer pulse generates 5 transitions per fan revolution (i.e., two fan tachometer periods per revolution, edges 2→6). One half of a revolution (one tachometer period) is equivalent to three edges (2→4 or 3→5). One quarter of a revolution (one-half tachometer period) is equivalent to two edges. To obtain the fan speed, count the number of 90Khz pulses that occurs between 2 edges i.e., 2→3, between 3 edges i.e., 2→4, or between 5 edges, i.e. 2→6 (the case of 9 edges is not shown). The time from 1-2 occurs through the guard time and is not to be used. For the discussion below, an edge is a high-to-low or low-to-high transition (edges are numbered – refer to Figure 4 - PWM and Tachometer Concept

The Tachometer circuit begins monitoring the tach when the associated PWM output transitions high and the guard time has expired. Each tach circuit will continue monitoring until either the “ON” time ends or the programmed number of edges has been detected, whichever comes first.

The Fan Tachometer value may be updated every 300ms, 500ms, or 1000ms.

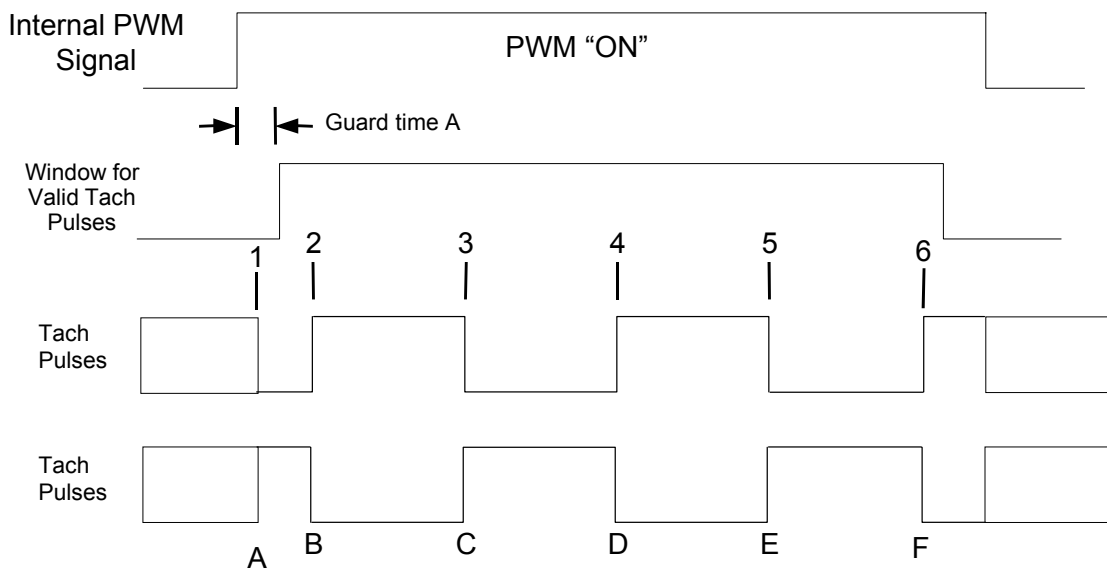

Figure 23.11 PWM and Tachometer Concept

FAN TACHOMETER OPTIONS FOR MODE 2

- 2, 3, 5 or 9 “edges” to calculate the fan speed (Figure 4)
- Guard time A is programmable (8-63 clocks) to account for delays in the system (Figure 4)
- Suggested PWM frequencies for mode 2 are: 11.0 Hz, 14.6 Hz, 21.9 Hz, 29.3 Hz, 35.2 Hz, 44.0 Hz, 58.6 Hz, 87.7Hz
- Option to ignore first 3 tachometer edges after guard time
- Option to force tach reading register to FFFEh to indicate a slow fan.

23.14.2.5 Fan Tachometer Reading Registers:

The Tachometer Reading registers are 16 bits, unsigned. When one byte of a 16-bit register is read, the other byte latches the current value until it is read, in order to ensure a valid reading. The order

is LSB first, MSB second. The value FFFFh indicates that the fan is not spinning, or the tachometer input is not connected to a valid signal (this could be triggered by a counter overflow). These registers are read only – a write to these registers has no effect.

Notes:

- The Fan Tachometer Reading registers always return an accurate fan tachometer measurement, even when a fan is disabled or non-functional.
- FFFFh indicates that the fan is not spinning, or the tachometer input is not connected to a valid signal (This could be triggered by a counter overflow).
- The Tachometer registers are read only – a write to these registers has no effect.
- Mode 1 should be enabled and the tachometer limit register should be set to FFFFh if a tachometer input is left unconnected.

23.14.2.6 Programming Options for Each Tachometer Input

The features defined in this section are programmable via the TACHx Option registers located at offsets 90h-92h and the PWMx Option registers located at offsets 94h-96h.

TACH READING UPDATE TIME

In Mode 1, the Fan Tachometer Reading registers are continuously updated. In Mode 2, the fan tachometer registers are updated every 300ms, 500msec, or 1000msec. This option is programmed via bits[1:0] in the PWMx Option register. The PWM associated with a particular TACH(s) determines the TACH update time.

PROGRAMMED NUMBER OF TACH EDGES

In modes 1 & 2, the number of edges is programmable for 2, 3, 5 or 9 edges (i.e., ½ tachometer pulse, 1 tachometer pulse, 2 tachometer pulses, 4 tachometer pulses). This option is programmed via bits[2:1] in the TachX Option register.

Note: The “5 edges” case corresponds to two tachometer pulses, or 1 RPM for most fans. Using the other edge options will require software to scale the values in the reading register to correspond to the count for 1 RPM.

GUARD TIME (MODE 2 ONLY)

The guard time is programmable from 8 to 63 clocks (90kHz). This option is programmed via bits[4:3] in the TachX Option register.

IGNORE FIRST 3 TACHOMETER EDGES (MODE 2 ONLY)

Option to ignore first 3 tachometer edges after guard time. This option is programmed for each tachometer via bits[2:0] in the TACHx Option register. Default is do not ignore first 3 tachometer edges after guard time.

23.14.2.7 Summary of Operation for Modes 1 & 2

The following summarizes the detection cases:

- **No edge occurs during the PWM ‘ON’ time:** indicate this condition as a stalled fan
 - The tachometer reading register contains FFFFh.
- **One edge (or less than programmed number of edges) occurs during the PWM ‘ON’ time:** indicate this condition as a slow fan.
 - If the SLOW bit is enabled, the tachometer reading register will be set to FFFEh to indicate that this is a slow fan instead of a seized fan. Note: This operation also pertains to the case where the tachometer counter reaches FFFFh before the programmed number of edges occurs.
 - If the SLOW bit is disabled, the tachometer reading register will be set to FFFFh. In this case, no distinction is made between a slow or seized fan.

Datasheet

Note: The Slow Interrupt Enable feature (SLOW) is configured in the TACHx Options registers at offsets 90h to 93h.

■ **The programmed number of edges occurs:**

-Mode 1: If the programmed number of edges occurs before the counter reaches FFFFh latch the tachometer count

-Mode 2: If the programmed number of edges occurs during the PWM 'ON' time: latch the tachometer count (see **Note** below).

Notes:

- Whenever the programmed number of edges is detected, the edge detection ends and the state machine is reset. The tachometer reading register is updated with the tachometer count value at this time. See [Detection of a Stalled Fan on page 222](#) for the exception to this behavior.
- In the case where the programmed number of edges occurs during the "on", the tachometer value is latched when the last required edge is detected.

23.14.2.8 Examples of Minimum RPMs Supported

The following tables show minimum RPMs that can be supported with the different parameters. The first table uses 3 edges and the second table uses 2 edges.

Table 23.5 Minimum RPM Detectable Using 3 Edges

PWM FREQUENCY	PULSE WIDTH AT DUTY CYCLE (PWM "ON" TIME)			MINIMUM RPM AT DUTY CYCLE (NOTE 23.2) (30/T _{TachPulse})		
	25% (MSEC)	50% (MSEC)	100% (MSEC) (NOTE 23.1)	25%	50%	100%
(HZ)						
87.7	2.85	5.7	11.36	10865	5347	2662
58.6	4.27	8.53	17	7175	3554	1774
44	5.68	11.36	22.64	5366	2662	1330
35.2	7.1	14.2	28.3	4279	2126	1063
29.3	8.53	17.06	34	3554	1768	885
21.9	11.42	22.83	45.48	2648	1319	661
14.6	17.12	34.25	68.23	1761	878	440
11	22.73	45.45	90.55	1325	661	332

Note 23.1 100% duty cycle is 255/256

Note 23.2 $RPM=60/T_{Revolution}$, $T_{TachPulse}=T_{Revolution}/2$. Using 3 edges for detection, $T_{TachPulse} = (PWM \text{ "ON" Time} - \text{Guard Time})$. Minimum RPM values shown use minimum guard time (88.88usec).

Table 23.6 Minimum RPM Detectable Using 2 Edges

PWM FREQUENCY (HZ)	PULSE WIDTH AT DUTY CYCLE (PWM "ON" TIME)			MINIMUM RPM AT DUTY CYCLE (NOTE 23.4) ($30/T_{TachPulse}$)		
	25% (MSEC)	50% (MSEC)	100% (MSEC) (NOTE 23.3)	25%	50%	100%
87.7	2.85	5.7	11.36	5433	2673	1331
58.6	4.27	8.53	17	3588	1777	887
44	5.68	11.36	22.64	2683	1331	665
35.2	7.1	14.2	28.3	2139	1063	532
29.3	8.53	17.06	34	1777	884	442
21.9	11.42	22.83	45.48	1324	660	330
14.6	17.12	34.25	68.23	881	439	220
11	22.73	45.45	90.55	663	331	166

Note 23.3 100% duty cycle is 255/256

Note 23.4 $RPM=60/T_{Revolution}$, $T_{TachPulse}=T_{Revolution}/2$. Using 2 edges for detection, $T_{TachPulse}=2*(PWM \text{ "ON" Time-Guard Time})$. Minimum RPM values shown use minimum guard time (88.88usec).

23.14.2.9 Detection of a Stalled Fan

There is a fan failure bit (TACHx) in the interrupt status register used to indicate that a slow or stalled fan event has occurred. If the tach reading value exceeds the value programmed in the tach limit register the interrupt status bit is set. See Interrupt Status register 2 at offset 42h.

Notes:

- The reading register will be forced to FFFFh if a stalled event occurs (i.e., stalled event =no edges detected.)
- The reading register will be forced to either FFFFh or FFFEh if a slow fan event occurs. (i.e., slow event: $0 < \#edges < \text{programmed } \#edges$). If the control bit, SLOW, located in the TACHx Options registers at offsets 90h - 93h, is set then FFFEh will be forced into the corresponding Tach Reading Register to indicate that the fan is spinning slowly.
- The fan tachometer reading register stays at FFFFh in the event of a stalled fan. If the fan begins to spin again, the tachometer logic will reset and latch the next valid reading into the tachometer reading register.

23.14.2.10 Fan Interrupt Status Bits

The status bits for the fan events are in Interrupt Status Register 2 (42h). These bits are set when the reading register is above the tachometer minimum and the Interrupt Enable 2 (Fan Tachs) register bits are configured to enable Fan Tach events. No interrupt status bits are set for fan events (even if the fan is stalled) if the associated tachometer minimum is set to FFFFh (registers 54h-5Bh).

Note: The Interrupt Enable 2 (Fan Tachs) register at offset 80h defaults to enabled for the individual tachometer status events bits. The group Fan Tach nHWM_INT bit defaults to disabled. This bit needs to be set if Fan Tach interrupts are to be generated on the external nHWM_INT pin.

See [Figure 23.3 Interrupt Control on page 193](#).

Datasheet

23.14.3 Locked Rotor Support for Tachometer Inputs

All tachometer inputs support locked rotor input mode. In this mode, the tachometer input pin is not used as a tachometer signal, but as a level signal. The active state of this signal (high or low) is the state that the fan's locked rotor signal indicates the locked condition.

The locked rotor signals that are supported are active high level and active low level. They are selectable for each tachometer. If the pin goes to its programmed active state, the associated interrupt status bit will be set. In addition, if properly configured, the nHWM_INT pin can be made to go active when the status bit is set.

The locked rotor input option is configured through the following bits:

- Tach1 Mode, bits[7:6] of Tach 1-3 Mode register.
- Tach2 Mode, bits[5:4] of Tach 1-3 Mode register.
- Tach3 Mode, bit[3:2] of Tach 1-3 Mode register.

These bits are defined as follows:

- 00=normal operation (default)
- 01=locked rotor mode, active high signal
- 10=locked rotor mode, active low signal
- 11=undefined.

23.14.4 Linking Fan Tachometers to PWMs

The TACH/PWM Association Register at offset 81h is used to associate a Tachometer input with a PWM output. This association has three purposes:

1. The auto fan control logic supports a feature called SpinUp Reduction. If SpinUp Reduction is enabled (SUREN bit), the auto fan control logic will stop driving the PWM output high if the associated TACH input is operating within normal parameters. (Note: SUREN bit is located in the Configuration Register at offset 7Fh)
2. To measure the tachometer input in Mode 2, the tachometer logic must know when the associated PWM is 'ON'.
3. Inhibit fan tachometer interrupts when the associated PWM is 'OFF'.

See the description of the PWM_TACH register. The default configuration is:

PWM1 -> FANTACH1.

PWM2 -> FANTACH2.

PWM3 -> FANTACH3.

Note: If a FANTACH is associated with a PWM operating in high frequency mode (see the Zonex Range/FANx Frequency registers (5Fh-61h)) the tach monitoring logic must be configured for Mode 1 (see Bit[3] Mode in FANTACHx Option Registers, 90h-92h).

23.15 High Frequency PWM Options

Note: If a fan with a tachometer output is driven by the high frequency PWM option, the tachometer must be monitored in Mode 1 only.

23.15.1 PWM Frequencies Supported

The SCH311X supports low frequency and high frequency PWMs. The low frequency options are 11.0Hz, 14.6Hz, 21.9Hz, 29.3Hz, 35.2Hz, 44.0Hz, 58.6Hz and 87.7Hz. The high frequency options are 15kHz, 20kHz, 25kHz and 30kHz. All PWM frequencies are derived from the 14.318MHz clock input.

The frequency of the PWM output is determined by the Frequency Select bits[3:0] as shown in PME_STS1. The default PWM frequency is 25kHz.

Datasheet

Chapter 24 Hardware Monitoring Register Set

These registers are accessed through an index and data register scheme using the HW_Reg_INDEX and HW_Reg_DATA registers located in the runtime register block at offset 70h and 71h from the address programmed in Logical Device A. The Hardware Monitor Block registers are located at the indexed address shown in [Table 24.1, "Register Summary"](#).

Definition for the Lock column:

Yes = Register is made read-only when the lock bit is set; No = Register is not made read-only when the lock bit is set.

Table 24.1 Register Summary

Reg Addr	Read /Write	Reg Name	Bit 7 MSB	Bit 6	Bit 5	Bit 4	Bit 3	Bit 2	Bit 1	Bit 0 LSB	Default Value	Lock
10h	R/W	SMSC Test Register	7	6	5	4	3	2	1	0	00h	No
1Dh	R/W	Offset Register Ambient	7	6	5	4	3	2	1	0	00h	Yes
1Eh	R/W	Offset Register 2	7	6	5	4	3	2	1	0	00h	Yes
1Fh	R/W	Offset Register 1	7	6	5	4	3	2	1	0	00h	Yes
20h	R	+2.5V	7	6	5	4	3	2	1	0	00h	No
21h	R	+1.5V Reading from Vccp pin	7	6	5	4	3	2	1	0	00h	No
22h	R	VCC	7	6	5	4	3	2	1	0	00h	No
23h	R	5V	7	6	5	4	3	2	1	0	00h	No
24h	R	12V	7	6	5	4	3	2	1	0	00h	No
25h	R	Remote Diode 1 (Zone 1) Temp Reading	7	6	5	4	3	2	1	0	00h	No
26h	R	Internal Temp (Zone 2) Reading	7	6	5	4	3	2	1	0	00h	No
27h	R	Remote Diode 2 (Zone 3) Temp Reading	7	6	5	4	3	2	1	0	00h	No
28h	R	FANTACH1 LSB	7	6	5	4	3	2	1	0	FFh Note 24.7	No
29h	R	FANTACH1 MSB	15	14	13	12	11	10	9	8	FFh Note 24.7	No
2Ah	R	FANTACH2 LSB	7	6	5	4	3	2	1	0	FFh Note 24.7	No
2Bh	R	FANTACH2 MSB	15	14	13	12	11	10	9	8	FFh Note 24.7	No
2Ch	R	FANTACH3 LSB	7	6	5	4	3	2	1	0	FFh Note 24.7	No
2Dh	R	FANTACH3 MSB	15	14	13	12	11	10	9	8	FFh Note 24.7	No
2Eh	R	Reserved	RES	RES	RES	RES	RES	RES	RES	RES	00h	No
2Fh	R	Reserved	RES	RES	RES	RES	RES	RES	RES	RES	00h	No
30h	R/W Note 24.1	PWM1 Current Duty Cycle	7	6	5	4	3	2	1	0	N/A Note 24.9 00	Yes Note 24.1
31h	R/W Note 24.1	PWM2 Current Duty Cycle	7	6	5	4	3	2	1	0	N/A Note 24.9 00	Yes Note 24.1
32h	R/W Note 24.1	PWM3 Current Duty Cycle	7	6	5	4	3	2	1	0	N/A Note 24.9 00	Yes
33-3Ch	R	Reserved	RES	RES	RES	RES	RES	RES	RES	RES	00h	No
3Dh	R	Device ID	7	6	5	4	3	2	1	0	8Ch	No
3Eh	R	Company ID	7	6	5	4	3	2	1	0	5Ch	No
3Fh	R	Revision	7	6	5	4	3	2	1	0	00h	No
40h	R/W Note 24.2	Ready/Lock/Start	RES	RES	RES	Vbat Mon	OVRID	READY	LOCK Note 24.8	START	04h	Yes Note 24.2
41h	R/WC Note 24.3	Interrupt Status Register 1	INT23	D2	AMB	D1	5V	VCC	Vccp	2.5V	00h Note 24.7	No
42h	R/WC Note 24.3	Interrupt Status Register 2	ERR2	ERR1	RES	FANTACH3	FANTACH2	FANTACH1	RES	12V	00h	No
43h	R	Reserved	RES	RES	RES	RES	RES	RES	RES	RES	00h	No

Table 24.1 Register Summary (continued)

Reg Addr	Read /Write	Reg Name	Bit 7 MSB	Bit 6	Bit 5	Bit 4	Bit 3	Bit 2	Bit 1	Bit 0 LSB	Default Value	Lock
44h	R	2.5V Low limit	7	6	5	4	3	2	1	0	00h	N/A
45h	R	2.5V High limit	7	6	5	4	3	2	1	0	FFh	N/A
46h	R	Vccp Low limit	7	6	5	4	3	2	1	0	00h	N/A
47h	R	Vccp High limit	7	6	5	4	3	2	1	0	FFh	N/A
48h	R	VCC Low limit	7	6	5	4	3	2	1	0	00h	N/A
49h	R	VCC High limit	7	6	5	4	3	2	1	0	FFh	N/A
4Ah	R	5V Low limit	7	6	5	4	3	2	1	0	00h	N/A
4Bh	R	5V High limit	7	6	5	4	3	2	1	0	FFh	N/A
4Ch	R	12V Low limit	7	6	5	4	3	2	1	0	00h	N/A
4Dh	R	12V High limit	7	6	5	4	3	2	1	0	FFh	N/A
4Eh	R/W	Remote Diode 1 Low Temp	7	6	5	4	3	2	1	0	81h	No
4Fh	R/W	Remote Diode 1 High Temp	7	6	5	4	3	2	1	0	7Fh	No
50h	R/W	Internal Diode Low Temp	7	6	5	4	3	2	1	0	81h	No
51h	R/W	Internal Diode High Temp	7	6	5	4	3	2	1	0	7Fh	No
52h	R/W	Remote Diode 2 Low Temp	7	6	5	4	3	2	1	0	81h	No
53h	R/W	Remote Diode 2 High Temp	7	6	5	4	3	2	1	0	7Fh	No
54h	R/W	FANTACH1 Minimum LSB	7	6	5	4	3	2	1	0	FFh	No
55h	R/W	FANTACH1 Minimum MSB	15	14	13	12	11	10	9	8	FFh	No
56h	R/W	FANTACH2 Minimum LSB	7	6	5	4	3	2	1	0	FFh	No
57h	R/W	FANTACH2 Minimum MSB	15	14	13	12	11	10	9	8	FFh	No
58h	R/W	FANTACH3 Minimum LSB	7	6	5	4	3	2	1	0	FFh	No
59h	R/W	FANTACH3 Minimum MSB	15	14	13	12	11	10	9	8	FFh	No
5Ah	R	Reserved	RES	RES	RES	RES	RES	RES	RES	RES	00h	No
5Bh	R	Reserved	RES	RES	RES	RES	RES	RES	RES	RES	00h	No
5Ch	R/W	PWM 1 Configuration	ZON2	ZON1	ZON0	INV	SUEN1	SPIN2	SPIN1	SPIN0	62h	Yes
5Dh	R/W	PWM 2 Configuration	ZON2	ZON1	ZON0	INV	SUEN2	SPIN2	SPIN1	SPIN0	62h	Yes
5Eh	R/W	PWM 3 Configuration	ZON2	ZON1	ZON0	INV	SUEN3	SPIN2	SPIN1	SPIN0	62h	Yes
5Fh	R/W	Zone 1 Range/PWM 1 Frequency	RAN3	RAN2	RAN1	RAN0	FRQ3	FRQ2	FRQ1	FRQ0	CBh	Yes
60h	R/W	Zone 2 Range/PWM 2 Frequency	RAN3	RAN2	RAN1	RAN0	FRQ3	FRQ2	FRQ1	FRQ0	CBh	Yes
61h	R/W	Zone 3 Range/PWM 3 Frequency	RAN3	RAN2	RAN1	RAN0	FRQ3	FRQ2	FRQ1	FRQ0	CBh	Yes
62h	R/W	Min/Off, PWM1 Ramp Rate Control	OFF3	OFF2	OFF1	RES	RR1E	RR1-2	RR1-1	RR1-0	00h	Yes
63h	R/W	PWM 2, PWM3 Ramp Rate Control	RR2E	RR2-2	RR2-1	RR2-0	RR3E	RR3-2	RR3-1	RR3-0	00h	Yes
64h	R/W	PWM 1 MINIMUM Duty Cycle	7	6	5	4	3	2	1	0	80h	Yes
65h	R/W	PWM 2 MINIMUM Duty Cycle	7	6	5	4	3	2	1	0	80h	Yes
66h	R/W	PWM 3 MINIMUM Duty Cycle	7	6	5	4	3	2	1	0	80h	Yes
67h	R/W	Zone 1 (Remote Diode 1) Low Temp Limit	7	6	5	4	3	2	1	0	23h Note 24.7	Yes
68h	R/W	Zone 2 (Ambient) Low Temp Limit	7	6	5	4	3	2	1	0	23h Note 24.7	Yes
69h	R/W	Zone 3 (Remote Diode 2) Low Temp Limit	7	6	5	4	3	2	1	0	23h Note 24.7	Yes
6Ah	R/W	Zone 1 Temp Absolute Limit	7	6	5	4	3	2	1	0	64h	Yes
6Bh	R/W	Zone 2 Temp Absolute Limit	7	6	5	4	3	2	1	0	64h	Yes
6Ch	R/W	Zone 3 Temp Absolute Limit	7	6	5	4	3	2	1	0	64h	Yes
6Dh	R/W	Zone 1, Zone 2 Hysteresis	H1-3	H1-2	H1-1	H1-0	H2-3	H2-2	H2-1	H2-0	44h	Yes
6Eh	R/W	Zone 3, Hysteresis	H3-3	H3-2	H3-1	H3-0	RES	RES	RES	RES	40h	Yes
6Fh	R	Reserved	RES	RES	RES	RES	RES	RES	RES	RES	00h	No
70h	R	SMSC Test Register	TST7	TST6	TST5	TST4	TST3	TST2	TST1	TST0	N/A	No
71h	R	SMSC Test Register	TST7	TST6	TST5	TST4	TST3	TST2	TST1	TST0	N/A	No
72h	R	SMSC Test Register	TST7	TST6	TST5	TST4	TST3	TST2	TST1	TST0	N/A	No
73h	R	SMSC Test Register	RES	RES	RES	RES	TST3	TST2	TST1	TST0	09h	No
74h	R/W	SMSC Test Register	RES	RES	RES	RES	TST3	TST2	TST1	TST0	09h	Yes
75h	R	SMSC Test Register	RES	RES	RES	RES	TST3	TST2	TST1	TST0	09h	No
76h	R/W	SMSC Test Register	RES	RES	RES	RES	TST3	TST2	TST1	TST0	09h	Yes
77h	R	SMSC Test Register	RES	RES	RES	RES	TST3	TST2	TST1	TST0	09h	No
78h	R/W	SMSC Test Register	RES	RES	RES	RES	TST3	TST2	TST1	TST0	09h	Yes

Datasheet

Table 24.1 Register Summary (continued)

Reg Addr	Read /Write	Reg Name	Bit 7 MSb	Bit 6	Bit 5	Bit 4	Bit 3	Bit 2	Bit 1	Bit 0 LSb	Default Value	Lock	
79h	R/W	SMSC Test Register	TST7	TST6	TST5	TST4	TST3	TST2	TST1	TST0	00h	Yes	
7Ah	R	Reserved	RES	RES	RES	RES	RES	RES	RES	RES	00h	No	
7Bh	R	Reserved	RES	RES	RES	RES	RES	RES	RES	RES	00h	No	
7Ch	R/W Note 2 4.4	Special Function Register	AVG2	AVG1	AVG0	SMSC Note 24. 6	SMSC Note 24. 6	INTEN	MON- MD	RES	40h	Yes	Note 24 .4
7Dh	R	Reserved	RES	RES	RES	RES	RES	RES	RES	RES	00h	No	
7Eh	R/W	Interrupt Enable Voltages	VCC	12V	5V	VTR	VCCP	2.5V	VBAT	VOLT	ECh	Yes	
7Fh	R/W	Configuration	INIT	SMSC Note 24. 6	SMSC Note 24. 6	SUREN	TRDY Note 24. 8	MON _DN	RES	RES	14h	Yes	complete monitor cycle
80h	R/W	Interrupt Enable (Fan Tachs)	RES	RES	RES	RES	FANTA CH3	FANTA CH2	FANTA CH1	FAN- TACH	0Eh	Yes	
81h	R/W	TACH_PWM Association	RES	RES	T3H	T3L	T2H	T2L	T1H	T1L	24h	Yes	
82h	R/W	Interrupt Enable (Temp)	RES	RES	RES	RES	D2EN	D1EN	AMB	TEMP	0Eh	Yes	
83h	RWC	Interrupt Status Register 3	RES	RES	RES	RES	RES	RES	VBAT	VTR	00h	No	
84h	R	A/D Converter LSbs Reg 5	VTR.3	VTR.2	VTR.1	VTR.0	VBAT.3	VBAT.2	VBAT.1	VBAT.0	00h	No	
85h	R	A/D Converter LSbs Reg 1	RD2.3	RD2.2	RD2.1	RD2.0	RD1.3	RD1.2	RD1.1	RD1.0	00h	No	
86h	R	A/D Converter LSbs Reg 2	V12.3	V12.2	V12.1	V12.0	AM.3	AM.2	AM.1	AM.0	00h	No	
87h	R	A/D Converter LSbs Reg 3	V50.3	V50.2	V50.1	V50.0	V25.3	V25.2	V25.1	V25.0	00h	No	
88h	R	A/D Converter LSbs Reg 4	VCC.3	VCC.2	VCC.1	VCC.0	VCP.3	VCP.2	VCP.1	VCP.0	00h	No	
89h	R	Reserved	RES	RES	RES	RES	RES	RES	RES	RES	00h	No	
8Ah	R	SMSC Test Register	RES	TST6	TST5	TST4	TST3	TST2	TST1	TST0	4Dh	No	
8Bh	R/W	SMSC Test Register	RES	TST6	TST5	TST4	TST3	TST2	TST1	TST0	4Dh	Yes	
8Ch	R	SMSC Test Register	RES	RES	RES	TST4	TST3	TST2	TST1	TST0	09h	No	
8Dh	R/W	SMSC Test Register	RES	RES	RES	TST4	TST3	TST2	TST1	TST0	09h	Yes	
8Eh	R	SMSC Test Register	TST7	TST6	TST5	TST4	TST3	TST2	TST1	TST0	N/A	No	
8Fh	R	Reserved	RES	RES	RES	RES	RES	RES	RES	RES	00h	No	
90h	R/W	FANTACH1 Option	SMSC	SMSC	SMSC	3EDG	MODE	EDG1	EDG0	SLOW	04h	No	
91h	R/W	FANTACH2 Option	SMSC	SMSC	SMSC	3EDG	MODE	EDG1	EDG0	SLOW	04h	No	
92h	R/W	FANTACH3 Option	SMSC	SMSC	SMSC	3EDG	MODE	EDG1	EDG0	SLOW	04h	No	
93h	R	Reserved	RES	RES	RES	RES	RES	RES	RES	RES	00h	No	
94h	R/W	PWM1 Option	RES Note 24. 5	RES Note 24. 5	OPP	GRD1	GRD0	SZEN	UPDT1	UPDT0	0Ch	No	
95h	R/W	PWM2 Option	RES Note 24. 5	RES Note 24. 5	OPP	GRD1	GRD0	SZEN	UPDT1	UPDT0	0Ch	No	
96h	R/W	PWM3 Option	RES Note 24. 5	RES Note 24. 5	OPP	GRD1	GRD0	SZEN	UPDT1	UPDT0	0Ch	No	
97h	R/W	SMSC Test Register	TST7	TST6	TST5	TST4	TST3	TST2	TST1	TST0	5Ah	Yes	
98h	R	SMSC Test Register	TST7	TST6	TST5	TST4	TST3	TST2	TST1	TST0	F1h	Yes	
99h	R	VTR Reading	7	6	5	4	3	2	1	0	00h	No	
9Ah	R	VBAT Reading	7	6	5	4	3	2	1	0	00h	No	
9Bh	R	VTR Limit Low	7	6	5	4	3	2	1	0	00h	No	
9Ch	R/W	VTR Limit Hi	7	6	5	4	3	2	1	0	FFh	No	
9Dh	R/W	VBAT Limit Low									00h	No	
9Eh	R/W	VBAT Limit Hi	7	6	5	4	3	2	1	0	FFh	No	
9Fh	R	Reserved	RES	RES	RES	RES	RES	RES	RES	RES	00h	No	
A0h	R	Reserved	RES	RES	RES	RES	RES	RES	RES	RES	00h	No	
A1h	R	Reserved	RES	RES	RES	RES	RES	RES	RES	RES	00h	No	
A2h	R	Reserved	RES	RES	RES	RES	RES	RES	RES	RES	00h	No	
A3h	R/W	SMSC Test Register	TST7	TST6	TST5	TST4	TST3	TST2	TST1	TST0	00h N/A	Yes	
A4h	R	SMSC Test Register	TST7	TST6	TST5	TST4	TST3	TST2	TST1	TST0	02h	No	
A5h	R/WC	Interrupt Status 1 Secondary	INT23	D2	AMB	D1	5V	VCC	Vccp	2.5V	00h Note 24.7	No	

Table 24.1 Register Summary (continued)

Reg Addr	Read /Write	Reg Name		Bit 7 MSb	Bit 6	Bit 5	Bit 4	Bit 3	Bit 2	Bit 1	Bit 0 LSB	Default Value	Lock	
A6h	R/W/C	Interrupt Status 2 Secondary		ERR2	ERR1	RES	FANTA CH3	FANTA CH2	FANTA CH1	RES	12V	00h Note 24.7	No	
A7h	RWC	Interrupt Status 3 Secondary	INS3	RES	RES	RES	RES	RES	RES	VBAT	VTR	00h	No	
A8h	R	Reserved		RES	RES	RES	RES	RES	RES	RES	RES	00h	No	
A9h	R/W	SMSC Test Register		7	6	5	4	3	2	1	0	00h	Yes	
AAh	R/W	SMSC Test Register		7	6	5	4	3	2	1	0	00h	Yes	
ABh	R/W	Tach 1-3 Mode		T1M1	T1M0	T2M1	T2M0	T3M1	T3M0	RES	RES	00h	No	
ACH	R	Reserved		RES	RES	RES	RES	RES	RES	RES	RES	00h	No	
ADh	R	SMSC Test Register		7	6	5	4	3	2	1	0	00h	No	
A Eh	R/W	Top Temperature Remote Diode 1 (Zone 1)		7	6	5	4	3	2	1	0	2Dh Note 24.7	Yes	
A Fh	R/W	Top Temperature Remote Diode 2 (Zone 3)		7	6	5	4	3	2	1	0	2Dh Note 24.7	Yes	
B0h	R	SMSC Test Register		RES	RES	RES	RES	RES	RES	RES	RES	00h	No	
B1h	R	SMSC Test Register		RES	RES	RES	RES	RES	RES	RES	RES	00h	No	
B2h	R	SMSC Test Register		RES	RES	RES	RES	RES	RES	RES	RES	00h	No	
B3h	R/W	Top Temperature Ambient (Zone 2)		7	6	5	4	3	2	1	0	2Dh Note 24.7	Yes	
B4h	R/W	Min Temp Adjust Temp RD1, RD2		R1ATP1	R1ATP0	R2ATP1	R2ATP0	RES	RES	RES	RES	00h	Yes	
B5h	R/W	Min Temp Adjust Temp and Delay Amb		RES	RES	AMATP 1	AMATP 0	RES	RES	AMAD1	AMAD0	00h	Yes	
B6h	R/W	Min Temp Adjust Delay 1-2		R1AD1	R1AD0	R2AD1	R2AD0	RES	RES	RES	RES	00h	Yes	
B7h	R/W	Tmin Adjust Enable		RES	RES	RES	RES	TMIN_ADJ_EN2	TMIN_ADJ_EN1	TMIN_ADJ_ENA	TOP_INT_EN	00h	Yes	
B8h	R/W/C	Top Temp Exceeded Status		RES	RES	RES	RES	RES	STS2	STS1	STSA	00h Note 24.7	No	
B9h	R	Reserved		RES	RES	RES	RES	RES	RES	RES	RES	00h	No	
BAh	R/W	SMSC Reserved		RES	RES	RES	RES	RES	RES	RES	RES	04h	Yes	
BBh	R	SMSC Reserved		7	6	5	4	3	2	1	0	00h	No	
BCh	R	Reserved		RES	RES	RES	RES	RES	RES	RES	RES	00h	No	
BDh	R	SMSC Reserved		7	6	5	4	3	2	1	0	00h	No	
BEh	R	Reserved		RES	RES	RES	RES	RES	RES	RES	RES	00h	No	
BFh	R/W	SMSC Reserved		RES	RES	RES	RES	RES	RES	RES	RES	00h	Yes	
C0h	R/W	SMSC Reserved		RES	RES	RES	RES	RES	RES	RES	RES	00h	Yes	
C1h	R/W	Thermtrip Control		RES	RES	RES	RES	RES	RES	RES	THERM_TRIP_C_TRL	01h	Yes	
C2h	R	Reserved		RES	RES	RES	RES	RES	RES	RES	RES	00h	No	
C3h	R	Reserved		RES	RES	RES	RES	RES	RES	RES	RES	00h	No	
C4h	R/W	ThermTrip Temp Limit RD1 (Zone 1)		7	6	5	4	3	2	1	0	7Fh	Yes	
C5h	R/W	ThermTrip Temp Limit RD2 (Zone 3)		7	6	5	4	3	2	1	0	7Fh	Yes	
C6h	R	Reserved		RES	RES	RES	RES	RES	RES	RES	RES	00h	No	
C7h	R	Reserved		RES	RES	RES	RES	RES	RES	RES	RES	00h	No	
C8h	R	Reserved		RES	RES	RES	RES	RES	RES	RES	RES	00h	No	
C9h	R/W	ThermTrip Temp Limit Amb (Zone 2)		7	6	5	4	3	2	1	0	7Fh	Yes	
CAh	R/W/C	ThermTrip Status		RES	RES	RES	RES	RES	RD 2	RD 1	AMB	00h Note 24.7	No	
CBh	R/W	ThermTrip Output Enable		RES	RES	RES	RES	RES	RD 2	RD 1	AMB	00h	Yes	
CCh	R	Reserved		RES	RES	RES	RES	RES	RES	RES	RES	00h	No	
CDh	R	Reserved		RES	RES	RES	RES	RES	RES	RES	RES	00h	No	
CEh	R/W	SMSC Reserved		RES	RES	RES	RES	RES	RES	RES	RES	00h	Yes	
CF-D0h	R/w	SMSC Test Register		TST7	TST6	TST5	TST4	TST3	TST2	TST1	TST0	00h	No	
D1h	R/W	PWM1 Max		7	6	5	4	3	2	1	0	FFh	Yes	
D2h-D5h	R	Reserved		RES	RES	RES	RES	RES	RES	RES	RES	00h	No	

Datasheet

Table 24.1 Register Summary (continued)

Reg Addr	Read /Write	Reg Name	Bit 7 MSb	Bit 6	Bit 5	Bit 4	Bit 3	Bit 2	Bit 1	Bit 0 LSB	Default Value	Lock	
D6h	R/W	PWM2 Max	7	6	5	4	3	2	1	0	FFh	Yes	
D7h-DAh	R	Reserved	RES	RES	RES	RES	RES	RES	RES	RES	00h	No	
DBh	R/W	PWM3 Max	7	6	5	4	3	2	1	0	FFh	Yes	
DCh-DFh	R	Reserved	RES	RES	RES	RES	RES	RES	RES	RES	00h	No	
E0h	R/W	Enable LSbs for AutoFan	RES	RES	PWM3_n1	PWM3_n0	PWM2_n1	PWM2_n0	PWM1_n1	PWM1_n0	00h	No	
E1-E8h	R	Reserved	RES	RES	RES	RES	RES	RES	RES	RES	00h	No	
E9h	R/W	SMSC Reserved	7	6	5	4	3	2	1	0	00h	Yes	
EAh	R	SMSC Reserved	7	6	5	4	3	2	1	0	00h	No	
EBh	R	SMSC Reserved	7	6	5	4	3	2	1	0	00h	No	
ECh	R/W	SMSC Reserved	7	6	5	4	3	2	1	0	00h	Yes	
EDh	R/W	SMSC Reserved	7	6	5	4	3	2	1	0	00h	Yes	
EEh	R/W	SMSC Reserved	RES	RES	RES	RES	RES	RES	RES	RES	00h	Yes	
FFh	R	SMSC Test Register	TST7	TST 6	TST 5	TST 4	TST3	TST2	TST1	TST0	N/A	No	

Note: SMSC Test Registers may be read/write registers. Writing these registers can cause unwanted results.

Note 24.1 The PWMx Current Duty Cycle Registers are only writable when the associated fan is in manual mode. In this case, the register is writable when the start bit is set, but not when the lock bit is set.

Note 24.2 The Lock and Start bits in the Ready/Lock/Start register are locked by the Lock Bit. The OVRID bit is always writable when the lock bit is set.

Note 24.3 The Interrupt status register bits are cleared on a write of 1 if the corresponding event is not active.

Note 24.4 The INTEN bit in register 7Ch is always writable, both when the start bit is set and when the lock bit is set.

Note 24.5 These Reserved bits are read/write bits. Writing these bits to a '1' has no effect on the hardware.

Note 24.6 SMSC bits may be read/write bits. Writing these bits to a value other than the default value may cause unwanted results

Note 24.7 This register is reset to its default value when the PWRGD_PS signal transitions high.

Note 24.8 This bit is reset to its default value when the PWRGD_PS signal transitions high.

Note 24.9 This register always reflects the state of the pin, unless it is in spinup. During spinup this register is forced to 00h.

24.1 Undefined Registers

The registers shown in the table above are the defined registers in the part. Any reads to undefined registers always return 00h. Writes to undefined registers have no effect and do not return an error.

24.2 Defined Registers

24.2.1 Register 10h: SMSC Test Register

Register Address	Read/Write	Register Name	Bit 7 (MSb)	Bit 6	Bit 5	Bit 4	Bit 3	Bit 2	Bit 1	Bit 0 (LSb)	Default Value
10h	R/W	SMSC TEST	TST7	TST6	TST5	TST4	TST3	TST2	TST1	TST0	00h

Setting the Lock bit has no effect on this registers

This register must not be written. Writing this register may produce unexpected results.

24.2.2 Register 1Dh, 1Eh, 1Fh: Offset Registers

Register Address	Read/Write	Register Name	Bit 7 (MSb)	Bit 6	Bit 5	Bit 4	Bit 3	Bit 2	Bit 1	Bit 0 (LSb)	Default Value
1Dh	R/W	Offset Register Ambient	7	6	5	4	3	2	1	0	00h
1Eh	R/W	Offset Register 2	7	6	5	4	3	2	1	0	00h
1Fh	R/W	Offset Register 1	7	6	5	4	3	2	1	0	00h

These registers become read only when the Lock bit is set. Any further attempts to write to these registers shall have no effect.

Offset Register Ambient only applies to the internal (ambient) temperature reading. This register contains a 2's complement value, which is added (or subtracted if the number is negative) to the ambient temperature reading. The default value in the offset register is zero, so initially zero is always added to the temperature reading.

Offset Register 2 only applies to the Zone 2 temperature reading. This register contains a 2's complement value, which is added (or subtracted if the number is negative) to external temperature reading 2. The default value in the offset register is zero, so initially zero is always added to the temperature reading.

Offset Register 1 only applies to the Zone 1 temperature reading. This register contains a 2's complement value, which is added (or subtracted if the number is negative) to the external temperature reading 1 reading. The default value in the offset register is zero, so initially zero is always added to the temperature reading.

24.2.3 Registers 20-24h, 99-9Ah: Voltage Reading

Register Address	Read/Write	Register Name	Bit 7 (MSb)	Bit 6	Bit 5	Bit 4	Bit 3	Bit 2	Bit 1	Bit 0 (LSb)	Default Value
20h	R	2.5V Reading	7	6	5	4	3	2	1	0	N/A
21h	R	Vccp Reading	7	6	5	4	3	2	1	0	N/A
22h	R	VCC Reading	7	6	5	4	3	2	1	0	N/A
23h	R	+5V Reading	7	6	5	4	3	2	1	0	N/A
24h	R	+12V Reading	7	6	5	4	3	2	1	0	N/A
99h	R	VTR Reading	7	6	5	4	3	2	1	0	N/A
9Ah	R	Vbat Reading	7	6	5	4	3	2	1	0	N/A

The Voltage Reading registers reflect the current voltage of the voltage monitoring inputs. Voltages are presented in the registers at $\frac{3}{4}$ full scale for the nominal voltage, meaning that at nominal voltage, each

Datasheet

register will read C0h, except for the Vbat input. Vbat is nominally a 3.0V input that is implemented on a +3.3V (nominal) analog input. Therefore, the nominal reading for Vbat is AEh.

Note: Vbat will only be monitored when the Vbat Monitoring Enable bit is set to '1'. Updating the Vbat register automatically clears the Vbat Monitoring Enable bit.

Table 24.2 Voltage vs. Register Reading

INPUT	NOMINAL VOLTAGE	REGISTER READING AT NOMINAL VOLTAGE	MAXIMUM VOLTAGE	REGISTER READING AT MAXIMUM VOLTAGE	MINIMUM VOLTAGE	REGISTER READING AT MINIMUM VOLTAGE
VTR	3.3V	C0h	4.38V	FFh	0V	00h
Vbat (Note 24.10)	3.0V	AEh	4.38V	FFh	0V	00h
5.0V	5.0V	C0h	6.64V	FFh	0V	00h
Vccp	1.5V	C0h	2.00V	FFh	0V	00h
VCC	3.3V	C0h	4.38V	FFh	0V	00h
2.5V	2.5V	C0h	6.64V	FFh	0V	00h
12V	12.0V	C0h	16.00V	FFh	0V	00h

Note 24.10 Vbat is a nominal 3.0V input source that has been implemented on a 3.3V analog voltage monitoring input.

The Voltage Reading registers will be updated automatically by the device with a minimum frequency of 4Hz if the average bits located in the Special Function register at offset 7Ch are set to 001. These registers are read only – a write to these registers has no effect.

24.2.4 Registers 25-27h: Temperature Reading

Register Address	Read/Write	Register Name	Bit 7 (MSb)	Bit 6	Bit 5	Bit 4	Bit 3	Bit 2	Bit 1	Bit 0 (LSb)	Default Value
25h	R	Remote Diode 1 (Zone 1) Temp Reading	7	6	5	4	3	2	1	0	N/A
26h	R	Internal Diode (Zone 2) Temp Reading	7	6	5	4	3	2	1	0	N/A
27h	R	Remote Diode 2 (Zone 3) Temp Reading	7	6	5	4	3	2	1	0	N/A

The Temperature Reading registers reflect the current temperatures of the internal and remote diodes. Remote Diode 1 Temp Reading register reports the temperature measured by the Remote1- and Remote1+ pins, Remote Diode 2 Temp Reading register reports the temperature measured by the Remote2- and Remote2+ pins, and the Internal Diode Temp Reading register reports the temperature measured by the internal (ambient) temperature sensor. Current temperatures are represented as 12 bit, 2's complement, signed numbers in Celsius. The 8MSBs are accessible in the temperature reading registers. Table 24.3 shows the conversion for the 8-bit reading value shown in these registers. The extended precision bits for these readings are accessible in the A/D Converter LSBs Register (85h-86h). The Temperature Reading register will return a value of 80h if the remote diode pins are not implemented by the board designer or are not functioning properly (this corresponds to the diode fault interrupt status bits). The Temperature Reading registers will be updated automatically by the SCH311X Chip with a minimum frequency of 4Hz.

Note: These registers are read only – a write to these registers has no effect.

Each of the temperature reading registers are mapped to a zone. Each PWM may be programmed to operate in the auto fan control operating mode by associating a PWM with one or more zones. The following is a list of the zone associations.

- Zone 1 is controlled by Remote Diode 1 Temp Reading
- Zone 2 is controlled by Internal Temp Reading (Ambient Temperature Sensor)
- Zone 3 is controlled by Remote Diode 2 Temp Reading

Note: To read a 12-bit reading value, software must read in the order of MSB then LSB. If several readings are being read at the same time, software can read all the MSB registers then the corresponding LSB registers. For example: Read RD1 Reading, RD2 Reading, then A/D Converter LSbs Reg1, which contains the LSbs for RD1 and RD2.

Table 24.3 Temperature vs. Register Reading

TEMPERATURE	READING (DEC)	READING (HEX)
-127°C	-127	81h
.	.	.
.	.	.
-50°C	-50	CEh
.	.	.
.	.	.
0°C	0	00h
.	.	.
.	.	.
50°C	50	32h
.	.	.
.	.	.
127°C	127	7Fh
(SENSOR ERROR)		80h

24.2.5 Registers 28-2Dh: Fan Tachometer Reading

Register Address	Read/Write	Register Name	Bit 7 (MSb)	Bit 6	Bit 5	Bit 4	Bit 3	Bit 2	Bit 1	Bit 0 (LSb)	Default Value
28h	R	FANTACH1 LSB	7	6	5	4	3	2	1	0	FFh
29h	R	FANTACH1 MSB	15	14	13	12	11	10	9	8	FFh
2Ah	R	FANTACH2 LSB	7	6	5	4	3	2	1	0	FFh
2Bh	R	FANTACH2 MSB	15	14	13	12	11	10	9	8	FFh
2Ch	R	FANTACH3 LSB	7	6	5	4	3	2	1	0	FFh
2Dh	R	FANTACH3 MSB	15	14	13	12	11	10	9	8	FFh

This register is reset to its default value when PWRGD_PS is asserted.

The Fan Tachometer Reading registers contain the number of 11.111µs periods (90KHz) between full fan revolutions. Fans produce two tachometer pulses per full revolution. These registers are updated at least once every second.

This value is represented for each fan in a 16 bit, unsigned number.

The Fan Tachometer Reading registers always return an accurate fan tachometer measurement, even when a fan is disabled or non-functional, including when the start bit=0.

Datasheet

When one byte of a 16-bit register is read, the other byte latches the current value until it is read, in order to ensure a valid reading. The order is LSB first, MSB second.

FFFFh indicates that the fan is not spinning, or the tachometer input is not connected to a valid signal (This could be triggered by a counter overflow).

These registers are read only – a write to these registers has no effect.

24.2.6 Registers 30-32h: Current PWM Duty

Register Address	Read/Write	Register Name	Bit 7 (MSb)	Bit 6	Bit 5	Bit 4	Bit 3	Bit 2	Bit 1	Bit 0 (LSb)	Default Value
30h	R/W (Note 24.11)	PWM1 Current Duty Cycle	7	6	5	4	3	2	1	0	N/A
31h	R/W (Note 24.11)	PWM2 Current Duty Cycle	7	6	5	4	3	2	1	0	N/A
32h	R/W (Note 24.11)	PWM3 Current Duty Cycle	7	6	5	4	3	2	1	0	N/A

Note 24.11 These registers are only writable when the associated fan is in manual mode. These registers become read only when the Lock bit is set. Any further attempts to write to these registers shall have no effect.

The Current PWM Duty registers store the duty cycle that the chip is currently driving the PWM signals at. At initial power-on, the duty cycle is 100% and thus, when read, this register will return FFh. After the Ready/Lock/Start Register Start bit is set, this register and the PWM signals are updated based on the algorithm described in the Auto Fan Control Operating Mode section and the Ramp Rate Control logic, unless the associated fan is in manual mode – see below.

Note: When the device is configured for Manual Mode, the Ramp Rate Control logic should be disabled.

When read, the Current PWM Duty registers return the current PWM duty cycle for the respective PWM signal.

These registers are read only – a write to these registers has no effect.

Note: If the current PWM duty cycle registers are written while the part is not in manual mode or when the start bit is zero, the data will be stored in internal registers that will only be active and observable when the start bit is set and the fan is configured for manual mode. While the part is not in manual mode and the start bit is zero, the current PWM duty cycle registers will read back FFh.

Manual Mode (Test Mode)

In manual mode, when the start bit is set to 1 and the lock bit is 0, the current duty cycle registers are writeable to control the PWMs.

Note: When the lock bit is set to 1, the current duty cycle registers are Read-Only.

The PWM duty cycle is represented as follows:

Table 24.4 PWM Duty vs Register Reading

CURRENT DUTY	VALUE (DECIMAL)	VALUE (HEX)
0%	0	00h
⋮	⋮	⋮
25%	64	40h
⋮	⋮	⋮
50%	128	80h
⋮	⋮	⋮
100%	255	FFh

During spin-up, the PWM duty cycle is reported as 0%.

Notes:

- The PWMx Current Duty Cycle always reflects the current duty cycle on the associated PWM pin.
- The PWMx Current Duty Cycle register is implemented as two separate registers: a read-only and a write-only. When a value is written to this register in manual mode there will be a delay before the programmed value can be read back by software. The hardware updates the read-only PWMx Current Duty Cycle register on the beginning of a PWM cycle. If Ramp Rate Control is disabled, the delay to read back the programmed value will be from 0 seconds to 1/(PWM frequency) seconds. Typically, the delay will be 1/(2*PWM frequency) seconds.

24.2.7 Register 3Dh: Device ID

Register Address	Read /Write	Register Name	Bit 7 (MSb)	Bit 6	Bit 5	Bit 4	Bit 3	Bit 2	Bit 1	Bit 0 (LSb)	Default Value
3Dh	R	Device ID	7	6	5	4	3	2	1	0	8Ch

The Device ID register contains a unique value to allow software to identify which device has been implemented in a given system.

24.2.8 Register 3Eh: Company ID

Register Address	Read /Write	Register Name	Bit 7 (MSb)	Bit 6	Bit 5	Bit 4	Bit 3	Bit 2	Bit 1	Bit 0 (LSb)	Default Value
3Eh	R	Company ID	7	6	5	4	3	2	1	0	5Ch

The company ID register contains a unique value to allow software to identify SMSC devices that been implemented in a given system.

24.2.9 Register 3Fh: Revision

Register Address	Read /Write	Register Name	Bit 7 (MSb)	Bit 6	Bit 5	Bit 4	Bit 3	Bit 2	Bit 1	Bit 0 (LSb)	Default Value
3Fh	R	Revision	7	6	5	4	3	2	1	0	00h

The Revision register contains the current version of this device.

Datasheet

The register is used by application software to identify which version of the device has been implemented in the given system. Based on this information, software can determine which registers to read from and write to. Further, application software may use the current stepping to implement work-arounds for bugs found in a specific silicon stepping.

This register is read only – a write to this register has no effect.

24.2.10 Register 40h: Ready/Lock/Start Monitoring

Register Address	Read/Write	Register Name	Bit 7 (MSb)	Bit 6	Bit 5	Bit 4	Bit 3	Bit 2	Bit 1	Bit 0 (LSb)	Default Value
40h	R/W	Ready/Lock/Start	RES	RES	RES	RES	OVRID	READY	LOCK Note 24.12	START	04h

Note 24.12 This LOCK bit is cleared when PWRGD_PS is asserted.

Setting the Lock bit makes the Lock and Start bits read-only.

BIT	NAME	R/W	DEFAULT	DESCRIPTION
0	START	R/W	0	<p>When software writes a 1 to this bit, the SCH311X enables monitoring and PWM output control functions based on the limit and parameter registers. Before this bit is set, the part does not update register values. Whenever this bit is set to 0, the monitoring and PWM output control functions are based on the default limits and parameters, regardless of the current values in the limit and parameter registers. The SCH311X preserves the values currently stored in the limit and parameter registers when this bit is set or cleared. This bit becomes read only when the Lock bit is set.</p> <p>Notes:</p> <ul style="list-style-type: none"> ■ When this bit is 0, all fans are on full 100% duty cycle, i.e., PWM pins are high for 255 clocks, low for 1 clock. When this bit is 0, the part is not monitoring. ■ It is suggested that software clear the START bit and exit auto fan control mode before modifying any fan configuration registers. After clearing the START bit, software should wait for a period of one 90kHz-10% clock (~12.5usec) before setting the START bit back to '1' to ensure the fan logic exited auto mode when START was cleared.
1	LOCK	R/W Note 24.13	0	Setting this bit to 1 locks specified limit and parameter registers. Once this bit is set, limit and parameter registers become read only and will remain locked until the device is powered off. This register bit becomes read only once it is set.
2	READY	R	0	The SCH311X sets this bit automatically after the part is fully powered up, has completed the power-up-reset process, and after all A/D converters are functioning (all bias conditions for the A/Ds have stabilized and the A/Ds are in operational mode). (Always reads back '1'.)
3	OVRID	R/W	0	If this bit is set to 1, all PWM outputs go to 100% duty cycle regardless of whether or not the lock bit is set.

BIT	NAME	R/W	DEFAULT	DESCRIPTION
4	VBAT Mon	R/W	0	<p>The Vbat Monitoring Enable bit determines if Vbat will be monitored on the next available monitoring cycle.</p> <p>This is a read/write bit. Writing this bit to a '1' will enable the Vbat input to be monitored on the next available monitoring cycle. Writing this bit to a '0' has no effect. This bit is cleared on an HVTR POR or when the Vbat register is updated. Software can poll this bit for a '0' after setting it to a '1' to determine when the Vbat register has been updated.</p> <p>0 = Vbat input is not being monitored (default) 1 = Vbat input is being monitored</p> <p>Note: The lock bit has no effect on this register bit.</p>
5-7	Reserved	R	0	Reserved

Note 24.13 This bit is set by software and cleared by hardware. Writing a '0' to this register has no effect.

Note 24.14 There is a start-up time of up to TBD ms (default - see PME_STS1) for monitoring after the start bit is set to '1', during which time the reading registers are not valid. Software can poll the TRDY bit located in the Configuration Register (7Fh) to determine when the voltage and temperature readings are valid. The following summarizes the operation of the part based on the Start bit:

1. If Start bit = '0' then:
 - a. Fans are set to Full On.
 - b. No temperature or fan tach monitoring is performed. The values in the reading registers will be N/A (Not Applicable), which means these values will not be considered valid readings until the Start bit = '1'. The exception to this is the Tachometer reading registers, which always give the actual reading on the TACH pins.
 - c. No Status bits are set.
2. If Start bit = '1'
 - a. All fan control and monitoring will be based on the current values in the registers. There is no need to preserve the default values after software has programmed these registers because no monitoring or auto fan control will be done when Start bit = '0'.
 - b. Status bits may be set.

Note: Once programmed, the register values will be saved when start bit is reset to '0'.

24.2.11 Register 41h: Interrupt Status Register 1

Register Address	Read/Write	Register Name	Bit 7 (MSb)	Bit 6	Bit 5	Bit 4	Bit 3	Bit 2	Bit 1	Bit 0 (LSb)	Default Value
41h	R/WC	Interrupt Status 1	INT2 Note 24.15	D2	AMB	D1	5V	VCC	Vccp	2.5V	00h

Note 24.15 This is a read-only bit. Writing '1' to this bit has no effect.

Notes:

- This register is reset to its default value when the PWRGD_PS signal transitions high.
- This is a read/write-to-clear register. Bits[6:4] are cleared on a write of one if the temperature event is no longer active. Writing a zero to these bits has no effect.

Datasheet**Bit[7] INT2**

This bit indicates that a status bit is set in the Interrupt Status Register 2 Register. Therefore, S/W can poll this register, and only if bit 7 is set does the other registers need to be read. This bit is cleared (set to 0) automatically by the device if there are no bits set in the Interrupt Status Register 2.

Bits[6:0] Individual Status Bits

Bits[6:0] of the Interrupt Status Register 1 are automatically set by the device whenever the measured temperature on Remote Diode 1, Internal Diode, or the Remote Diode 2 Temperature violates the limits set in the corresponding temperature limit registers. These individual status bits remain set until the bit is written to one by software or until the individual enable bit is cleared, even if the temperatures no longer violate the limits set in the limit registers.

- Clearing the status bits by a write of '1'
The voltage status bits are cleared (set to 0) automatically by the SCH311X after they are written to one by software, if the voltage readings no longer violate the limit set in the limit registers. See [Registers 44-4Dh, 9B-9Eh: Voltage Limit Registers on page 239](#).
The temperature status bits are cleared (set to 0) automatically by the SCH311X after they are written to one by software, if the temperature readings no longer violate the limit set in the limit registers. See [Registers 4E-53h: Temperature Limit Registers on page 241](#).
- Clearing the status bits by clearing the individual enable bits.
Clearing or setting the individual enable bits does not take effect unless the START bit is 1. No interrupt status events can be generated when START=0 or when the individual enable bit is cleared. If the status bit is one and the START bit is one then clearing the individual enable bit will immediately clear the status bit. If the status bit is one and the START bit is zero then clearing the individual enable bit will have no effect on the status bit until the START bit is set to one. Setting the START bit to one when the individual enable bit is zero will clear the status bit. Setting or clearing the START bit when the individual enable bit is one has no effect on the status bits.

Notes:

- The individual enable bits for D2, AMB, and D1 are located in the Interrupt Enable 3 (Temp) register at offset 82h.
- Clearing the group Temp enable bit or the global INTEN enable bit has no effect on the status bits.

BIT	NAME	R/W	DEFAULT	DESCRIPTION
0	2.5V_Error	R/WC	0	The SCH311X automatically sets this bit to 1 when the 2.5V input voltage is less than or equal to the limit set in the 2.5V Low Limit register or greater than the limit set in the 2.5V High Limit register.
1	Vccp_Error	R/WC	0	The SCH311X automatically sets this bit to 1 when the Vccp input voltage is less than or equal to the limit set in the Vccp Low Limit register or greater than the limit set in the Vccp High Limit register.
2	VCC_Error	R/WC	0	The SCH311X automatically sets this bit to 1 when the VCC input voltage is less than or equal to the limit set in the VCC Low Limit register or greater than the limit set in the VCC High Limit register.
3	5V_Error	R/WC	0	The SCH311X automatically sets this bit to 1 when the 5V input voltage is less than or equal to the limit set in the 5V Low Limit register or greater than the limit set in the 5V High Limit register.
4	Remote Diode 1 Limit Error	R/WC	0	The SCH311X automatically sets this bit to 1 when the temperature input measured by the Remote1- and Remote1+ is less than or equal to the limit set in the Remote Diode 1 Low Temp register or greater than the limit set in Remote Diode 1 High Temp register.
5	Internal Sensor Limit Error	R/WC	0	The SCH311X automatically sets this bit to 1 when the temperature input measured by the internal temperature sensor is less than or equal to the limit set in the Internal Low Temp register or greater than the limit set in the Internal High Temp register.
6	Remote Diode 2 Limit Error	R/WC	0	The SCH311X automatically sets this bit to 1 when the temperature input measured by the Remote2- and Remote2+ is less than or equal to the limit set in the Remote Diode 2 Low Temp register or greater than the limit set in the Remote Diode 1 High Temp register.
7	INT2 Event Active	R/WC	0	The device automatically sets this bit to 1 when a status bit is set in the Interrupt Status Register 2.

24.2.12 Register 42h: Interrupt Status Register 2

Register Address	Read/Write	Register Name	Bit 7 (MSb)	Bit 6	Bit 5	Bit 4	Bit 3	Bit 2	Bit 1	Bit 0 (LSb)	Default Value
42h	R/WC	Interrupt Status Register 2	ERR2	ERR1	RES	FANTACH3	FANTACH2	FANTACH1	RES	12V	00h

Notes:

- This register is reset to its default value when the PWRGD_PS signal transitions high.
- This is a read/write-to-clear register. The status bits are cleared on a write of one if the event causing the interrupt is no longer active. Writing a zero to these bits has no effect.

The Interrupt Status Register 2 bits is automatically set by the device whenever a tach reading value is above the minimum value set in the tachometer minimum registers or when a remote diode fault occurs. When a remote diode fault occurs (if the start bit is set) 80h will be loaded into the associated temperature reading register, which causes the associated diode limit error bit to be set (see [Register 41h: Interrupt Status Register 1 on page 236](#)) in addition to the diode fault bit (ERRx). These individual status bits remain set until the bit is written to one by software or until the individual enable bit is cleared, even if the event no longer persists.

- Clearing the status bits by a write of '1'
 The FANTACHx status bits are cleared (set to 0) automatically by the SCH311X after they are written to one by software, if the FANTACHx reading register no longer violates the programmed FANTACH Limit. (See [Registers 28-2Dh: Fan Tachometer Reading on page 232](#) and [Registers 54-59h: Fan Tachometer Low Limit on page 242](#))
 The ERRx status bits are cleared (set to 0) automatically by the SCH311X after they are written to one by software, if the Diode Fault condition no longer exists. The remote diode fault bits do not get cleared while the fault condition exists.

Datasheet

- Clearing the status bits by clearing the individual enable bits.
Clearing or setting the individual enable bits does not take effect unless the START bit is 1. No interrupt status events can be generated when START=0 or when the individual enable bit is cleared. If the status bit is one and the START bit is one then clearing the individual enable bit will immediately clear the status bit. If the status bit is one and the START bit is zero then clearing the individual enable bit will have no effect on the status bit until the START bit is set to one. Setting the START bit to one when the individual enable bit is zero will clear the status bit. Setting or clearing the START bit when the individual enable bit is one has no effect on the status bits.

Notes:

- The individual enable bits for FANTACH[1:3] are located in [Register 80h: Interrupt Enable 2 Register on page 254](#). The ERRx bits are enabled by the Remote Diode Limit error bits located in [Register 82h: Interrupt Enable 3 Register on page 255](#)
- Clearing the group FANTACH or Temp enable bits or the global INTEN enable bit has no effect on the status bits.

BIT	NAME	R/W	DEFAULT	DESCRIPTION
0	+12v_Error	R	0	The SCH311X automatically sets this bit to 1 when the 12V input voltage is less than or equal to the limit set in the 12V Low Limit register or greater than the limit set in the 12V High Limit register.
1	Reserved	R	0	Reserved
2	FANTACH1 Slow/Stalled	R/WC	0	The SCH311X automatically sets this bit to 1 when the FANTACH1 input reading is above the value set in the Tach1 Minimum MSB and LSB registers.
3	FANTACH2 Slow/Stalled	R/WC	0	The SCH311X automatically sets this bit to 1 when the FANTACH2 input reading is above the value set in the Tach2 Minimum MSB and LSB registers.
4	FANTACH3 Slow/Stalled	R/WC	0	The SCH311X automatically sets this bit to 1 when the FANTACH3 input reading is above the value set in the Tach3 Minimum MSB and LSB registers.
5	Reserved	R	0	Reserved
6	Remote Diode 1 Fault	R/WC	0	The SCH311X automatically sets this bit to 1 when there is either a short or open circuit fault on the Remote1+ or Remote1- thermal diode input pins as defined in the sectionPME_STS1. If the START bit is set and a fault condition exists, the Remote Diode 1 reading register will be forced to 80h.
7	Remote Diode 2 Fault	R/WC	0	The SCH311X automatically sets this bit to 1 when there is either a short or open circuit fault on the Remote2+ or Remote2- thermal diode input pins as defined in the sectionPME_STS1. If the START bit is set and a fault condition exists, the Remote Diode 2 reading register will be forced to 80h.

24.2.13 Registers 44-4Dh, 9B-9Eh: Voltage Limit Registers

Register Address	Read/Write	Register Name	Bit 7 (MSb)	Bit 6	Bit 5	Bit 4	Bit 3	Bit 2	Bit 1	Bit 0 (LSb)	Default Value
44h	R/W	2.5V Low Limit	7	6	5	4	3	2	1	0	00h
45h	R/W	2.5V High Limit	7	6	5	4	3	2	1	0	FFh
46h	R/W	Vccp Low Limit	7	6	5	4	3	2	1	0	00h
47h	R/W	Vccp High Limit	7	6	5	4	3	2	1	0	FFh
48h	R/W	VCC Low Limit	7	6	5	4	3	2	1	0	00h

Register Address	Read/Write	Register Name	Bit 7 (MSb)	Bit 6	Bit 5	Bit 4	Bit 3	Bit 2	Bit 1	Bit 0 (LSb)	Default Value
49h	R/W	VCC High Limit	7	6	5	4	3	2	1	0	FFh
4Ah	R/W	5V Low Limit	7	6	5	4	3	2	1	0	00h
4Bh	R/W	5V High Limit	7	6	5	4	3	2	1	0	FFh
4Ch	R/W	12V Low Limit	7	6	5	4	3	2	1	0	00h
4Dh	R/W	12V High Limit	7	6	5	4	3	2	1	0	FFh
9Bh	R/W	VTR Low Limit	7	6	5	4	3	2	1	0	00h
9Ch	R/W	VTR High Limit	7	6	5	4	3	2	1	0	FFh
9Dh	R/W	Vbat Low Limit	7	6	5	4	3	2	1	0	00h
9Eh	R/W	Vbat High Limit	7	6	5	4	3	2	1	0	FFh

Setting the Lock bit has no effect on these registers.

If a voltage input either exceeds the value set in the voltage high limit register or falls below or equals the value set in the voltage low limit register, the corresponding bit will be set automatically in the interrupt status registers (41-42h, 83h). Voltages are presented in the registers at ¼ full scale for the nominal voltage, meaning that at nominal voltage, each register will read C0h, except for the Vbat input. Vbat is nominally a 3.0V input that is implemented on a +3.3V (nominal) analog input. Therefore, the nominal reading for Vbat is AEh.

Note: Vbat will only be monitored when the Vbat Monitoring Enable bit is set to '1'. Updating the Vbat reading register automatically clears the Vbat Monitoring Enable bit.

Table 24.5 Voltage Limits vs. Register Setting

INPUT	NOMINAL VOLTAGE	REGISTER READING AT NOMINAL VOLTAGE	MAXIMUM VOLTAGE	REGISTER READING AT MAXIMUM VOLTAGE	MINIMUM VOLTAGE	REGISTER READING AT MINIMUM VOLTAGE
VTR	3.3V	C0h	4.38V	FFh	0V	00h
Vbat (Note 2 4.16)	3.0V	AEh	4.38V	FFh	0V	00h
2.5V	5.0V	C0h	6.64V	FFh	0V	00h
Vccp	2.25V	C0h	3.00V	FFh	0V	00h
VCC	3.3V	C0h	4.38V	FFh	0V	00h
5V	5.0V	C0h	6.64V	FFh	0V	00h
12V	12.0V	C0h	16.00V	FFh	0V	00h

Note 24.16 Vbat is a nominal 3.0V input source that has been implemented on a 3.3V analog voltage monitoring input.

Datasheet

24.2.14 Registers 4E-53h: Temperature Limit Registers

Register Address	Read/Write	Register Name	Bit 7 (MSb)	Bit 6	Bit 5	Bit 4	Bit 3	Bit 2	Bit 1	Bit 0 (LSb)	Default Value
4Eh	R/W	Remote Diode 1 Low Temp	7	6	5	4	3	2	1	0	81h
4Fh	R/W	Remote Diode 1 High Temp	7	6	5	4	3	2	1	0	7Fh
50h	R/W	Ambient Low Temp	7	6	5	4	3	2	1	0	81h
51h	R/W	Ambient High Temp	7	6	5	4	3	2	1	0	7Fh
52h	R/W	Remote Diode 2 Low Temp	7	6	5	4	3	2	1	0	81h
53h	R/W	Remote Diode 2 High Temp	7	6	5	4	3	2	1	0	7Fh

Setting the Lock bit has no effect on these registers.

If an external temperature input or the internal temperature sensor either exceeds the value set in the high limit register or is less than or equal to the value set in the low limit register, the corresponding bit will be set automatically by the SCH311X in the Interrupt Status Register 1 (41h). For example, if the temperature reading from the Remote1- and Remote1+ inputs exceeds the Remote Diode 1 High Temp register limit setting, Bit[4] D1 of the Interrupt Status Register 1 will be set. The temperature limits in these registers are represented as 8 bit, 2's complement, signed numbers in Celsius, as shown below in [Table 24.6](#).

Table 24.6 Temperature Limits vs. Register Settings

TEMPERATURE	LIMIT (DEC)	LIMIT (HEX)
-127°C	-127	81h
.	.	.
.	.	.
-50°C	-50	CEh
.	.	.
.	.	.
0°C	0	00h
.	.	.
.	.	.
50°C	50	32h
.	.	.
.	.	.
127°C	127	7Fh

24.2.15 Registers 54-59h: Fan Tachometer Low Limit

Register Address	Read/Write	Register Name	Bit 7 (MSb)	Bit 6	Bit 5	Bit 4	Bit 3	Bit 2	Bit 1	Bit 0 (LSb)	Default Value
54h	R/W	FANTACH1 Minimum LSB	7	6	5	4	3	2	1	0	FFh
55h	R/W	FANTACH1 Minimum MSB	15	14	13	12	11	10	9	8	FFh
56h	R/W	FANTACH2 Minimum LSB	7	6	5	4	3	2	1	0	FFh
57h	R/W	FANTACH2 Minimum MSB	15	14	13	12	11	10	9	8	FFh
58h	R/W	FANTACH3 Minimum LSB	7	6	5	4	3	2	1	0	FFh
59h	R/W	FANTACH3 Minimum MSB	15	14	13	12	11	10	9	8	FFh

Setting the Lock bit has no effect on these registers.

The Fan Tachometer Low Limit registers indicate the tachometer reading under which the corresponding bit will be set in the Interrupt Status Register 2 register. In Auto Fan Control mode, the fan can run at high speeds (100% duty cycle), so care should be taken in software to ensure that the limit is low enough not to cause sporadic alerts. Note that an interrupt status event will be generated when the tachometer reading is greater than the minimum tachometer limit.

The fan tachometer will not cause a bit to be set in the interrupt status register if the current value in the associated Current PWM Duty registers is 00h or if the PWM is disabled via the PWM Configuration Register.

Interrupts will never be generated for a fan if its tachometer minimum is set to FFFFh.

24.2.16 Registers 5C-5Eh: PWM Configuration

Register Address	Read/Write	Register Name	Bit 7 (MSb)	Bit 6	Bit 5	Bit 4	Bit 3	Bit 2	Bit 1	Bit 0 (LSb)	Default Value
5Ch	R/W	PWM 1 Configuration	ZON2	ZON1	ZON0	INV	SUEN1	SPIN2	SPIN1	SPIN0	62h
5Dh	R/W	PWM 2 Configuration	ZON2	ZON1	ZON0	INV	SUEN2	SPIN2	SPIN1	SPIN0	62h
5Eh	R/W	PWM 3 Configuration	ZON2	ZON1	ZON0	INV	SUEN3	SPIN2	SPIN1	SPIN0	62h

These registers become read only when the Lock bit is set. Any further attempts to write to these registers shall have no effect.

Bits [7:5] Zone/Mode

Bits [7:5] of the PWM Configuration registers associate each PWM with a temperature zone.

- When in Auto Fan Mode, the PWM will be assigned to a zone, and its PWM duty cycle will be adjusted according to the temperature of that zone. If 'Hottest' option is selected (101 or 110), the PWM will be controlled by the hottest of zones 2 and 3, or of zones 1, 2, and 3. If one of these options is selected, the PWM is controlled by the limits and parameters for the zone that requires the highest PWM duty cycle, as computed by the auto fan algorithm.
- When in manual control mode, the PWMx Current Duty Cycle Registers (30h-32h) become Read/Write. It is then possible to control the PWM outputs with software by writing to these registers. See PWMx Current Duty Cycle Registers description.
- When the fan is disabled (100) the corresponding PWM output is driven low (or high, if inverted).
- When the fan is Full On (011) the corresponding PWM output is driven high (or low, if inverted).

Notes:

- Zone 1 is controlled by Remote Diode 1 Temp Reading register

Datasheet

- Zone 2 is controlled by the Ambient Reading Register.
- Zone 3 is controlled by Remote Diode 2 Temp Reading register

Table 24.7 Fan Zone Setting

ZON[7:5]	PWM CONFIGURATION
000	Fan on zone 1 auto
001	Fan on zone 2 auto
010	Fan on zone 3 auto
011	Fan always on full
100	Fan disabled
101	Fan controlled by hottest of zones 2,3
110	Fan controlled by hottest of zones 1,2,3
111	Fan manually controlled

Bit [4] PWM Invert

Bit [4] inverts the PWM output. If set to 1, 100% duty cycle will yield an output that is low for 255 clocks and high for 1 clock. If set to 0, 100% duty cycle will yield an output that is high for 255 clocks and low for 1 clock.

Bit [3] Forced Spin-up Enable

Bit [3] enables the forced spin up option for a particular PWM. If set to 1, the forced spin-up feature is enabled for the associated PWM. If set to 0, the forced spin-up feature is disabled for the associated PWM.

APPLICATION NOTE: This bit should always be enabled (set) to prevent fan tachometer interrupts during spinup.

Bits [2:0] Spin Up

Bits [2:0] specify the 'spin up' time for the fan. When a fan is being started from a stationary state, the PWM output is held at 100% duty cycle for the time specified in the table below before scaling to a lower speed. Note: during spin-up, the PWM pin is forced high for the duration of the spin-up time (i.e., 100% duty cycle = 256/256)

Note: To reduce the spin-up time, this device has implemented a feature referred to as Spin Up Reduction. Spin Up Reduction uses feedback from the tachometers to determine when each fan has started spinning properly. Spin up for a PWM will end when the tachometer reading register is below the minimum limit, or the spin-up time expires, whichever comes first. All tachs associated with a PWM must be below min. for spin-up to end prematurely. This feature can be disabled by clearing bit 4 (SUREN) of the Configuration register (7Fh). If disabled, the all fans go on full for the duration of their associated spin up time. Note that the Tachx minimum registers must be programmed to a value less than FFFFh in order for the spin-up reduction to work properly.

Table 24.8 Fan Spin-Up Register

SPIN[2:0]	SPIN UP TIME
000	0 sec
001	100ms
010	250ms (default)
011	400ms
100	700ms
101	1000ms
110	2000ms
111	4000ms

24.2.17 Registers 5F-61h: Zone Temperature Range, PWM Frequency

Register Address	Read /Write	Register Name	Bit 7 (MSb)	Bit 6	Bit 5	Bit 4	Bit 3	Bit 2	Bit 1	Bit 0 (LSb)	Default Value
5Fh	R/W	Zone 1 Range / Fan 1 Frequency	RAN3	RAN2	RAN1	RAN0	FRQ3	FRQ2	FRQ1	FRQ0	CBh
60h	R/W	Zone 2 Range / Fan 2 Frequency	RAN3	RAN2	RAN1	RAN0	FRQ3	FRQ2	FRQ1	FRQ0	CBh
61h	R/W	Zone 3 Range / Fan 3 Frequency	RAN3	RAN2	RAN1	RAN0	FRQ3	FRQ2	FRQ1	FRQ0	CBh

These registers become read only when the Lock bit is set. Any further attempts to write to these registers shall have no effect.

In Auto Fan Mode, when the temperature for a zone is above the Low Temperature Limit (registers 67-69h) and below the Absolute Temperature Limit (registers 6A-6Ch) the speed of a fan assigned to that zone is determined as follows by the auto fan control logic.

When the temperature reaches the temperature value programmed in the Zone x Low Temp Limit register, the PWM output assigned to that zone is at PWMx Minimum Duty Cycle. Between Zone x Low Temp Limit and (Zone x Low Temp Limit + Zone x Range), the PWM duty cycle increases linearly according to the temperature as shown in the figure below.

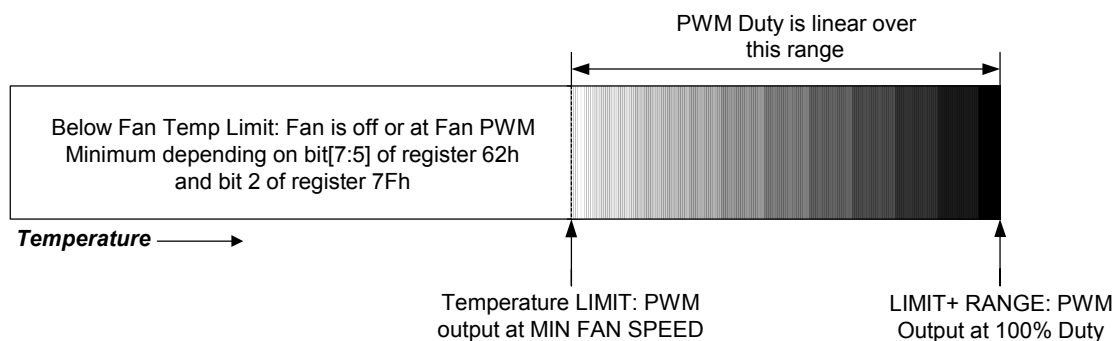
Figure 24.1 Fan Activity Above Fan Temp Limit

Example for PWM1 assigned to Zone 1:

- Zone 1 Low Temp Limit (Register 67h) is set to 50°C (32h).
- Zone 1 Range (Register 5Fh) is set to 8°C (7h)
- PWM1 Minimum Duty Cycle (Register 64h) is set to 50% (80h)

In this case, the PWM1 duty cycle will be 50% at 50°C.

Datasheet

Since (Zone 1 Low Temp Limit) + (Zone 1 Range) = 50°C + 8°C = 58°C, the fan controlled by PWM1 will run at 100% duty cycle when the temperature of the Zone 1 sensor is at 58°C.

Since the midpoint of the fan control range is 54°C, and the median duty cycle is 75% (Halfway between the PWM Minimum and 100%), PWM1 duty cycle would be 75% at 54°C.

Above (Zone 1 Low Temp Limit) + (Zone 1 Range), the duty cycle must be 100%.

The PWM frequency bits [3:0] determine the PWM frequency for the fan. If the high frequency option is selected the associated FANTACH inputs must be configured for Mode 1.

24.2.17.1 PWM Frequency Selection (Default =1011 bits=25kHz)**Table 24.9 PWM Frequency Selection**

FREQUENCY SELECT BITS[3:0]	FREQUENCY 14.318MHZ CLOCK SOURCE
0000	11.0 Hz
0001	14.6 Hz
0010	21.9 Hz
0011	29.3 Hz
0100	35.2 Hz
0101	44.0 Hz
0110	58.6 Hz
0111	87.7 Hz
1000	15kHz
1001	20kHz
1010	30kHz
1011	25kHz (default)
1100	Reserved
1101	Reserved
1110	Reserved
1111	Reserved

24.2.17.2 Range Selection (Default =1100=32°C)**Table 24.10 Register Setting vs. Temperature Range**

RAN[3:0]	RANGE (°C)
0000	2
0001	2.5
0010	3.33
0011	4
0100	5
0101	6.67
0110	8

Table 24.10 Register Setting vs. Temperature Range (continued)

RAN[3:0]	RANGE (°C)
0111	10
1000	13.33
1001	16
1010	20
1011	26.67
1100	32
1101	40
1110	53.33
1111	80

Note: The range numbers will be used to calculate the slope of the PWM ramp up. For the fractional entries, the PWM will go on full when the temp reaches the next integer value e.g., for 3.33, PWM will be full on at (min. temp + 4).

24.2.18 Register 62h, 63h: Min/Off, PWM Ramp Rate Control

Register Address	Read /Write	Register Name	Bit 7 (MSb)	Bit 6	Bit 5	Bit 4	Bit 3	Bit 2	Bit 1	Bit 0 (LSb)	Default Value
62h	R/W	Min/Off, PWM 1 Ramp Rate Control	OFF3	OFF2	OFF1	RES	RR1E	RR1-2	RR1-1	RR1-0	00h
63h	R/W	PWM 2, PWM 3 Ramp Rate Control	RR2E	RR2-2	RR2-1	RR2-0	RR3E	RR3-2	RR3-1	RR3-0	00h

These registers become read only when the Lock bit is set. Any further attempts to write to these registers shall have no effect.

Description of OFFx bits:

The OFFx Bits [7:5] specify whether the duty cycle will be set to 0% or the Minimum Fan Duty Cycle when the measured temperature falls below the Temperature LIMIT register setting. OFF1 applies to PWM1, OFF2 applies to PWM2, and OFF3 applies to PWM3.

Table 24.11 PWM output below Limit depending on value of Off/Min

OFF/MIN	PWM ACTION
0	At 0% duty below LIMIT
1	At Min PWM Duty below LIMIT

Description of Ramp Rate Control bits:

If the Remote1 or Remote2 pins are connected to a processor or chipset, instantaneous temperature spikes may be sampled by the part. The auto fan control logic calculates the PWM duty cycle for all temperature readings. If Ramp Rate Control is disabled, the PWM output will jump or oscillate between different PWM duty cycles causing the fan to suddenly change speeds, which creates unwanted fan noise. If enabled, the PWM Ramp Rate Control logic will prevent the PWM output from jumping, instead the PWM will ramp up/down towards the new duty cycle at a pre-determined ramp rate.

Ramp Rate Control

The Ramp Rate Control logic limits the amount of change to the PWM duty cycle over a period of time. This period of time is programmable via the Ramp Rate Control bits. For a detailed description of the

Datasheet

Ramp Rate Control bits see [Table 24.12](#). For a description of the Ramp Rate Control logic see PME_STS1.

Notes:

- RR1E, RR2E, and RR3E enable PWM Ramp Rate Control for PWM 1, 2, and 3 respectively.
- RR1-2, RR1-1, and RR1-0 control ramp rate time for PWM 1
- RR2-2, RR2-1, and RR2-0 control ramp rate time for PWM 2
- RR3-2, RR3-1, and RR3-0 control ramp rate time for PWM 3

Table 24.12 PWM Ramp Rate Control

RRX-[2:0]	PWM RAMP TIME (SEC) (TIME FROM 33% DUTY CYCLE TO 100% DUTY CYCLE)	PWM RAMP TIME (SEC) (TIME FROM 0% DUTY CYCLE TO 100% DUTY CYCLE)	TIME PER PWM STEP (PWM STEP SIZE = 1/255)	PWM RAMP RATE (HZ)
000	35	52.53	206 msec	4.85
001	17.6	26.52	104 msec	9.62
010	11.8	17.595	69 msec	14.49
011	7.0	10.455	41 msec	24.39
100	4.4	6.63	26 msec	38.46
101	3.0	4.59	18 msec	55.56
110	1.6	2.55	10 msec	100
111	0.8	1.275	5 msec	200

Note: This assumes the Ramp Rate Enable bit (RRxE) is set.

24.2.19 Registers 64-66h: Minimum PWM Duty Cycle

Register Address	Read/Write	Register Name	Bit 7 (MSb)	Bit 6	Bit 5	Bit 4	Bit 3	Bit 2	Bit 1	Bit 0 (LSb)	Default Value
64h	R/W	PWM1 Minimum Duty Cycle	7	6	5	4	3	2	1	0	80h
65h	R/W	PWM2 Minimum Duty Cycle	7	6	5	4	3	2	1	0	80h
66h	R/W	PWM3 Minimum Duty Cycle	7	6	5	4	3	2	1	0	80h

These registers become read only when the Lock bit is set. Any further attempts to write to these registers shall have no effect.

These registers specify the minimum duty cycle that the PWM will output when the measured temperature reaches the Temperature LIMIT register setting in Auto Fan Control Mode.

Table 24.13 PWM Duty vs. Register Setting

MINIMUM PWM DUTY	VALUE (DECIMAL)	VALUE (HEX)
0%	0	00h
.	.	.
.	.	.
25%	64	40h
.	.	.
.	.	.
50%	128	80h
.	.	.
.	.	.
100%	255	FFh

24.2.20 Registers 67-69h: Zone Low Temperature Limit

Register Address	Read/Write	Register Name	Bit 7 (MSb)	Bit 6	Bit 5	Bit 4	Bit 3	Bit 2	Bit 1	Bit 0 (LSb)	Default Value
67h	R/W	Zone 1 (Remote Diode 1) Low Temp Limit	7	6	5	4	3	2	1	0	23h Note 24.17
68h	R/W	Zone 2 (Ambient) Low Temp Limit	7	6	5	4	3	2	1	0	23h Note 24.17
69h	R/W	Zone 3 (Remote Diode 2) Low Temp Limit	7	6	5	4	3	2	1	0	23h Note 24.17

Note 24.17 This register is reset to the default value following a VCC POR when the PWRGD_PS signal is asserted.

These registers become read only when the Lock bit is set. Any further attempts to write to these registers shall have no effect.

These are the temperature limits for the individual zones. When the current temperature equals this limit, the fan will be turned on if it is not already. When the temperature exceeds this limit, the fan speed will be increased according to the auto fan algorithm based on the setting in the Zone x Range / PWMx Frequency register. Default = 90°C=5Ah

Table 24.14 Temperature Limit vs. Register Setting

LIMIT	LIMIT (DEC)	LIMIT (HEX)
-127°C	-127	81h
.	.	.
.	.	.
-50°C	-50	CEh
.	.	.
.	.	.
0°C	0	00h

Table 24.14 Temperature Limit vs. Register Setting (continued)

LIMIT	LIMIT (DEC)	LIMIT (HEX)
.	.	.
.	.	.
50°C	50	32h
.	.	.
.	.	.
127°C	127	7Fh

24.2.21 Registers 6A-6Ch: Absolute Temperature Limit

Register Address	Read/Write	Register Name	Bit 7 (MSb)	Bit 6	Bit 5	Bit 4	Bit 3	Bit 2	Bit 1	Bit 0 (LSb)	Default Value
6Ah	R/W	Zone 1 Temp Absolute Limit	7	6	5	4	3	2	1	0	64h
6Bh	R/W	Zone 2 Temp Absolute Limit	7	6	5	4	3	2	1	0	64h
6Ch	R/W	Zone 3 Temp Absolute Limit	7	6	5	4	3	2	1	0	64h

These registers become read only when the Lock bit is set. Any further attempts to write to these registers shall have no effect.

In Auto Fan mode, if any zone associated with a PWM output exceeds the temperature set in the Absolute limit register, all PWM outputs will increase their duty cycle to 100% except those that are disabled via the PWM Configuration registers. This is a safety feature that attempts to cool the system if there is a potentially catastrophic thermal event.

If an absolute limit register set to 80h (-128°C), the safety feature is disabled for the associated zone. That is, if 80h is written into the Zone x Temp Absolute Limit Register, then regardless of the reading register for the zone, the fans will not turn on-full based on the absolute temp condition.

Default =100°C=64h.

When any fan is in auto fan mode, then if the temperature in any zone exceeds absolute limit, all fans go to full, including any in manual mode, except those that are disabled. Therefore, even if a zone is not associated with a fan, if that zone exceeds absolute, then all fans go to full. In this case, the absolute limit can be chosen to be 7Fh for those zones that are not associated with a fan, so that the fans won't turn on unless the temperature hits 127 degrees.

Table 24.15 Absolute Limit vs. Register Setting

ABSOLUTE LIMIT	ABS LIMIT (DEC)	ABS LIMIT (HEX)
-127°C	-127	81h
.	.	.
.	.	.
-50°C	-50	CEh
.	.	.
.	.	.
0°C	0	00h
.	.	.
.	.	.

Table 24.15 Absolute Limit vs. Register Setting (continued)

ABSOLUTE LIMIT	ABS LIMIT (DEC)	ABS LIMIT (HEX)
50°C	50	32h
.	.	.
.	.	.
127°C	127	7Fh

24.2.22 Registers 6D-6Eh: Zone Hysteresis Registers

Register Address	Read/Write	Register Name	Bit 7 (MSb)	Bit 6	Bit 5	Bit 4	Bit 3	Bit 2	Bit 1	Bit 0 (LSb)	Default Value
6Dh	R/W	Zone 1, Zone 2 Hysteresis	H1-3	H1-2	H1-1	H1-0	H2-3	H2-2	H2-1	H2-0	44h
6Eh	R/W	Zone 3, Hysteresis	H3-3	H3-2	H3-1	H3-0	RES	RES	RES	RES	40h

These registers become read only when the Lock bit is set. Any further attempts to write to these registers shall have no effect.

If the temperature is above the Zone x Low Temp Limit, then drops below Zone x Low Temp Limit, the following will occur:

The fan will remain on, at Fan PWM Minimum, until the temperature goes a certain amount below the associated zones low temperature limit (see Zone x Low Temp Limit registers). That is, when the temperature is less than the temperature limit minus the hysteresis value, the fan will turn off.

The Hysteresis registers control this amount. See below table for details.

Table 24.16 Hysteresis Settings

SETTING	HYSTERESIS
0h	0°C
.	.
.	.
5h	5°C
.	.
.	.
Fh	15°C

24.2.23 Register 70-72h: SMSC Test Register

Register Address	Read/Write	Register Name	Bit 7 (MSb)	Bit 6	Bit 5	Bit 4	Bit 3	Bit 2	Bit 1	Bit 0 (LSb)	Default Value
70h	R	SMSC Test Register	7	6	5	4	3	2	1	0	N/A
71h	R	SMSC Test Register	7	6	5	4	3	2	1	0	N/A
72h	R	SMSC Test Register	7	6	5	4	3	2	1	0	N/A

This is a read-only smsc test register. Writing to this register has no effect.

Datasheet

24.2.24 Register 73-78h: SMSC Test Register

Register Address	Read /Write	Register Name	Bit 7 (MSb)	Bit 6	Bit 5	Bit 4	Bit 3	Bit 2	Bit 1	Bit 0 (LSb)	Default Value
73h	R	SMSC Test Register	RES	RES	RES	RES	TST3	TST2	TST1	TST0	09h
74h	R/W	SMSC Test Register	RES	RES	RES	RES	TST3	TST2	TST1	TST0	09h
75h	R	SMSC Test Register	RES	RES	RES	RES	TST3	TST2	TST1	TST0	09h
76h	R/W	SMSC Test Register	RES	RES	RES	RES	TST3	TST2	TST1	TST0	09h
77h	R	SMSC Test Register	RES	RES	RES	RES	TST3	TST2	TST1	TST0	09h
78h	R/W	SMSC Test Register	RES	RES	RES	RES	TST3	TST2	TST1	TST0	09h

These are SMSC Test registers. Writing to these registers may cause unwanted results.

24.2.25 Register 79h: SMSC Test Register

Register Address	Read /Write	Register Name	Bit 7 (MSb)	Bit 6	Bit 5	Bit 4	Bit 3	Bit 2	Bit 1	Bit 0 (LSb)	Default Value
79h	R/W	SMSC Test Register	TST7	TST6	TST5	TST4	TST3	TST2	TST1	TST0	00h

This is a read/write register. Writing this register may produce unwanted results.

This register becomes read only when the Lock bit is set. Any further attempts to write to this register shall have no effect.

24.2.26 Register 7Ch: Special Function Register

Register Address	Read /Write	Register Name	Bit 7 (MSb)	Bit 6	Bit 5	Bit 4	Bit 3	Bit 2	Bit 1	Bit 0 (LSb)	Default Value
7Ch	R/W	Special Function	AVG2	AVG1	AVG0	SMSC	SMSC	INT_EN	MONMD	RES	E0h

This register becomes read only when the Lock bit is set. Any further attempts to write to this register shall have no effect.

This register contains the following bits:

Bit[0] Reserved

Bit[1] Monitoring Mode Select

0= Continuous Monitor Mode (default)

1= Cycle Monitor Mode

Bit[2] Interrupt (nHWM_INT Pin) Enable

0=Disables nHWM_INT pin output function (default)

1=Enables nHWM_INT pin output function

Bit[3] SMSC Reserved

This is a read/write bit. Reading this bit has no effect. Writing this bit to '1' may cause unwanted results.

Bit [4] SMSC Reserved

This is a read/write bit. Reading this bit has no effect. Writing this bit to '1' may cause unwanted results.

Bits [7:5] AVG[2:0]

The AVG[2:0] bits determine the amount of averaging for each of the measurements that are performed by the hardware monitor before the reading registers are updated (TABLE 22). The AVG[2:0] bits are priority encoded where the most significant bit has highest priority. For example, when the AVG2 bit is asserted, 32 averages will be performed for each measurement before the reading registers are updated regardless of the state of the AVG[1:0] bits.

Table 24.17 AVG[2:0] BIT DECODER

SFTR[7:5]			AVERAGES PER READING		
AVG2	AVG1	AVG0	REM DIODE 1	REM DIODE 2	INTERNAL DIODE
0	0	0	128	128	8
0	0	1	16	16	1
0	1	X	16	16	16
1	X	X	32	32	32

Note: The default for the AVG[2:0] bits is '010'b.

24.2.27 Register 7Eh: Interrupt Enable 1 Register

Register Address	Read/Write	Register Name	Bit 7 (MSb)	Bit 6	Bit 5	Bit 4	Bit 3	Bit 2	Bit 1	Bit 0 (LSb)	Default Value
7Eh	R/W	Interrupt Enable 1 (Voltages)	VCC	12V	5V	VTR	VCCP	2.5V	VBAT	VOLT	ECh

This register becomes read only when the Lock bit is set. Any further attempts to write to this register shall have no effect.

This register is used to enable individual voltage error events to set the corresponding status bits in the interrupt status registers. This register also contains the group voltage enable bit (Bit[0] VOLT), which is used to enable voltage events to force the interrupt pin (nHWM_INT) low if interrupts are enabled (see Bit[2] INTEN of the Special Function register at offset 7Ch).

This register contains the following bits:

Bit[0] Group interrupt Voltage Enable (VOLT)

0=Out-of-limit voltages do not affect the state of the nHWM_INT pin (default)

1=Enable out-of-limit voltages to make the nHWM_INT pin active low

Bit[1] VBAT Error Enable

Bit[2] 2.5V Error Enable

Bit[3] Vccp Error Enable

Bit[4] VTR Error Enable

Bit[5] 5V Error Enable

Bit[6] 12V Error Enable

Bit[7] VCC Error Enable

Datasheet

The individual voltage error event bits are defined as follows:

0=disable

1=enable.

See [Figure 23.3 Interrupt Control on page 193](#).

24.2.28 Register 7Fh: Configuration Register

Register Address	Read /Write	Register Name	Bit 7 (MSb)	Bit 6	Bit 5	Bit 4	Bit 3	Bit 2	Bit 1	Bit 0 (LSb)	Default Value
7Fh	R/W	Configuration	INIT	SMSC	SMSC	SUREN	TRDY Note 24.18	MON_DN	RES	RES	10h

Note 24.18 TRDY is cleared when the PWRGD_PS signal is asserted.

These registers become read only when the Lock bit is set. Any further attempts to write to these registers shall have no effect.

This register contains the following bits:

Bit[0] Reserved

Bit[1] Reserved

Bit[2] MON_DN: This bit is used to detect when the monitoring cycle is completed following the START bit being set to 0. When the START bit is cleared, the hardware monitoring block always completes the monitoring cycle. 0= monitoring cycle active, 1= monitoring cycle complete.

APPLICATION NOTE: When the START bit is 1, and the device is monitoring, this bit will toggle each time it completes the monitoring cycle. It is intended that the user only read this bit when the START bit is 0.

Bit[3] TRDY: Temperature Reading Ready. This bit indicates that the temperature reading registers have valid values. This bit is used after writing the start bit to '1'. 0= not valid, 1=valid.

Bit[4] SUREN: Spin-up reduction enable. This bit enables the reduction of the spin-up time based on feedback from all fan tachometers associated with each PWM. 0=disable, 1=enable (default)

Bit[5] SMSC Reserved

This is an SMSC Reserved bit. Writing this bit to a value different than the default value may cause unwanted results.

Bit[5] SMSC Reserved

This is an SMSC Reserved bit. Writing this bit to a value different than the default value may cause unwanted results.

Bit[6] SMSC Reserved

This is an SMSC Reserved bit. Writing this bit to a value different than the default value may cause unwanted results.

Bit[7] Initialization

Setting the INIT bit to '1' performs a soft reset. This bit is self-clearing. Soft Reset sets all the registers except the Reading Registers to their default values.

24.2.29 Register 80h: Interrupt Enable 2 Register

Register Address	Read/Write	Register Name	Bit 7 (MSb)	Bit 6	Bit 5	Bit 4	Bit 3	Bit 2	Bit 1	Bit 0 (LSb)	Default Value
80h	R/W	Interrupt Enable 2 (Fan Tachs)	RES	RES	RES	RES	FANTACH3	FANTACH2	FANTACH1	FANTACH	1Eh

These registers become read only when the Lock bit is set. Any further attempts to write to these registers shall have no effect.

This register is used to enable individual fan tach error events to set the corresponding status bits in the interrupt status registers. This register also contains the group fan tach enable bit (Bit[0] TACH), which is used to enable fan tach events to force the interrupt pin (nHWM_INT) low if interrupts are enabled (see Bit[2] INTEN of the Special Function register at offset 7Ch).

This register contains the following bits:

Bit[0] FANTACH (Group TACH Enable)

0=Out-of-limit tachometer readings do not affect the state of the nHWM_INT pin (default)

1=Enable out-of-limit tachometer readings to make the nHWM_INT pin active low

Bit[1] Fantach 1 Event Enable

Bit[2] Fantach 2 Event Enable

Bit[3] Fantach 3 Event Enable

Bit[4] Reserved

Bit[5] Reserved

Bit[6] Reserved

Bit[7] Reserved

The individual fan tach error event bits are defined as follows:

0=disable

1=enable.

See PME_STS1.

24.2.30 Register 81h: TACH_PWM Association Register

Register Address	Read/Write	Register Name	Bit 7 (MSb)	Bit 6	Bit 5	Bit 4	Bit 3	Bit 2	Bit 1	Bit 0 (LSb)	Default Value
81h	R/W	TACH_PWM Association	RES	RES	T3H	T3L	T2H	T2L	T1H	T1L	24h

These registers become read only when the Lock bit is set. Any further attempts to write to these registers shall have no effect.

This register is used to associate a PWM with a tachometer input. This association is used by the fan logic to determine when to prevent a bit from being set in the interrupt status registers.

The fan tachometer will not cause a bit to be set in the interrupt status register:

- if the current value in Current PWM Duty registers is 00h or
- if the fan is disabled via the Fan Configuration Register.

Datasheet

Note: A bit will never be set in the interrupt status for a fan if its tachometer minimum is set to FFFFh.

See bit definition below.

Bits[1:0] Tach1. These bits determine the PWM associated with this Tach. See bit combinations below.

Bits[3:2] Tach2. These bits determine the PWM associated with this Tach. See bit combinations below.

Bits[5:4] Tach3. These bits determine the PWM associated with this Tach. See bit combinations below.

Bits[7:6] Reserved

BITS[1:0], BITS[3:2], BITS[5:4], BITS[7:6]	PWM ASSOCIATED WITH TACHX
00	PWM1
01	PWM2
10	PWM3
11	Reserved

Notes:

- Any PWM that has no TACH inputs associated with it must be configured to operate in Mode 1.
- All TACH inputs must be associated with a PWM output. If the tach is not being driven by the associated PWM output it should be configured to operate in Mode 1 and the associated TACH interrupt must be disabled.

24.2.31 Register 82h: Interrupt Enable 3 Register

Register Address	Read /Write	Register Name	Bit 7 (MSb)	Bit 6	Bit 5	Bit 4	Bit 3	Bit 2	Bit 1	Bit 0 (LSb)	Default Value
82h	R/W	Interrupt Enable 3 (Temp)	RES	RES	RES	RES	D2EN	D1EN	AMB	TEMP	0Eh

These registers become read only when the Lock bit is set. Any further attempts to write to these registers shall have no effect.

This register is used to enable individual thermal error events to set the corresponding status bits in the interrupt status registers. This register also contains the group thermal enable bit (Bit[0] TEMP), which is used to enable thermal events to force the interrupt pin (nHWM_INT) low if interrupts are enabled (see Bit[2] INTEN of the Special Function register at offset 7Ch).

This register contains the following bits:

Bit[0] TEMP. Group temperature enable bit.

0=Out-of-limit temperature readings do not affect the state of the nHWM_INT pin (default)

1=Enable out-of-limit temperature readings to make the nHWM_INT pin active low

Bit[1] ZONE 2 Temperature Status Enable bit.

Bit[2] ZONE 1 Temperature Status Enable bit.

Bit[3] ZONE 3 Temperature Status Enable bit

Bit[4] Reserved

Bit[5] Reserved

Bit[6] Reserved

Bit[7] Reserved

The individual thermal error event bits are defined as follows:

0=disable

1=enable.

24.2.32 Register 83h: Interrupt Status Register 3

Register Address	Read/Write	Register Name	Bit 7 (MSb)	Bit 6	Bit 5	Bit 4	Bit 3	Bit 2	Bit 1	Bit 0 (LSb)	Default Value
83h	RWC ¹	Interrupt Status 3	RES	RES	RES	RES	RES	RES	Vbat	VTR	00h

Note: This is a read/write-to-clear register. The status bits are cleared on a write of one if the event causing the interrupt is no longer active. Writing a zero to these bits has no effect.

The Interrupt Status Register 3 bits[1:0] are automatically set by the device whenever a voltage event occurs on the VTR or Vbat inputs. A voltage event occurs when any of these inputs violate the limits set in the corresponding limit registers.

This register holds a set bit until the event is cleared by software or until the individual enable bit is cleared. Once set, the Interrupt Status Register 3 bits remain set until the individual enable bits is cleared, even if the voltage or tachometer reading no longer violate the limits set in the limit registers. Note that clearing the group Temp, Fan, or Volt enable bits or the global INTEN enable bit has no effect on the status bits.

Note: The individual enable bits for VTR and Vbat are located in the Interrupt Enable 1 register at offset 7Eh.

This register is read only – a write to this register has no effect.

BIT	NAME	R/W	DEFAULT	DESCRIPTION
0	VTR_Error	R	0	The device automatically sets this bit to 1 when the VTR input voltage is less than or equal to the limit set in the VTR Low Limit register or greater than the limit set in the VTR High Limit register.
1	Vbat_Error	R	0	The device automatically sets this bit to 1 when the Vbat input voltage is less than or equal to the limit set in the Vbat Low Limit register or greater than the limit set in the Vbat High Limit register.
2-7	Reserved	R	0	Reserved

24.2.33 Registers 84h-88h: A/D Converter LSbs Registers

Register Address	Read/Write	Register Name	Bit 7 (MSb)	Bit 6	Bit 5	Bit 4	Bit 3	Bit 2	Bit 1	Bit 0 (LSb)	Default Value
84h	R	A/D Converter LSbs Reg 5	VTR.3	VTR.2	VTR.1	VTR.0	VBT.3	VBT.2	VBT.1	VBT.0	N/A
85h	R	A/D Converter LSbs Reg 1	RD2.3	RD2.2	RD2.1	RD2.0	RD1.3	RD1.2	RD1.1	RD1.0	N/A
86h	R	A/D Converter LSbs Reg 2	V12.3	V12.2	V12.1	V12.0	AM.3	AM.2	AM.1	AM.0	N/A
87h	R	A/D Converter LSbs Reg 3	V50.3	V50.2	V50.1	V50.0	V25.3	V25.2	V25.1	V25.0	N/A
88h	R	A/D Converter LSbs Reg 4	VCC.3	VCC.2	VCC.1	VCC.0	VCP.3	VCP.2	VCP.1	VCP.0	N/A

Datasheet

There is a 10-bit Analog to Digital Converter (ADC) located in the hardware monitoring block that converts the measured voltages into 10-bit reading values. Depending on the averaging scheme enabled (i.e., 16x averaging, 32x averaging, etc.), the hardware monitor may take multiple readings and average them to create 12-bit reading values. The 8 MSb's of the reading values are placed in the Reading Registers. When the upper 8-bits located in the reading registers are read the 4 LSb's are latched into their respective bits in the A/D Converter LSbs Register. This give 12-bits of resolution with a minimum value of 1/16th per unit measured. (i.e., Temperature Range: -127.9375 °C < Temp < 127.9375 °C and Voltage Range: 0 < Voltage < 256.9375). See the DC Characteristics for the accuracy of the reading values.

The eight most significant bits of the 12-bit averaged readings are stored in Reading registers and compared with Limit registers. The Interrupt Status Register bits are asserted if the corresponding measured value(s) on the inputs violate their programmed limits.

24.2.34 Registers Registers 89h: SMSC Test Register

Register Address	Read /Write	Register Name	Bit 7 (MSb)	Bit 6	Bit 5	Bit 4	Bit 3	Bit 2	Bit 1	Bit 0 (LSb)	Default Value
89h	R	SMSC Test Register	7	6	5	4	3	2	1	0	N/A

This is a read-only SMSC test register. Writing to this register has no effect on the hardware.

24.2.35 Registers 8Ah: SMSC Test Register

Register Address	Read/ Write	Register Name	Bit 7 (MSb)	Bit 6	Bit 5	Bit 4	Bit 3	Bit 2	Bit 1	Bit 0 (LSb)	Default Value
8Ah	R	SMSC Test Register	RES	TST6	TST5	TST4	TST3	TST2	TST1	TST0	4Dh

24.2.36 Registers 8Bh: SMSC Test Register

Register Address	Read/ Write	Register Name	Bit 7 (MSb)	Bit 6	Bit 5	Bit 4	Bit 3	Bit 2	Bit 1	Bit 0 (LSb)	Default Value
8Bh	R/W	SMSC Test Register	RES	TST6	TST5	TST4	TST3	TST2	TST1	TST0	4Dh

This register becomes read only when the Lock bit is set. Any further attempts to write to this register shall have no effect.

This register must not be written. Writing this register may produce unexpected results.

24.2.37 Registers 8Ch: SMSC Test Register

Register Address	Read/ Write	Register Name	Bit 7 (MSb)	Bit 6	Bit 5	Bit 4	Bit 3	Bit 2	Bit 1	Bit 0 (LSb)	Default Value
8Ch	R	SMSC Test Register	RES	RES	RES	TST4	TST3	TST2	TST1	TST0	0Eh

24.2.38 Registers 8Dh: SMSC Test Register

Register Address	Read/ Write	Register Name	Bit 7 (MSb)	Bit 6	Bit 5	Bit 4	Bit 3	Bit 2	Bit 1	Bit 0 (LSb)	Default Value
8Dh	R/W	SMSC Test Register	RES	RES	RES	TST4	TST3	TST2	TST1	TST0	0Eh

This register becomes read only when the Lock bit is set. Any further attempts to write to this register shall have no effect.

This register must not be written. Writing this register may produce unexpected results.

24.2.39 Registers 8Eh: SMSC Test Register

Register Address	Read /Write	Register Name	Bit 7 (MSb)	Bit 6	Bit 5	Bit 4	Bit 3	Bit 2	Bit 1	Bit 0 (LSb)	Default Value
8Eh	R	SMSC Test Register	TST7	TST6	TST5	TST4	TST3	TST2	TST1	TST0	N/A

This register is an SMSC Test register.

24.2.40 Registers 90h-92h: FANTACHX Option Registers

Register Address	Read /Write	Register Name	Bit 7 (MSb)	Bit 6	Bit 5	Bit 4	Bit 3	Bit 2	Bit 1	Bit 0 (LSb)	Default Value
90h	R/W	FANTACH1 Option	RES	RES	RES	3EDG	MODE	EDG1	EDG0	SLOW	04h
91h	R/W	FANTACH2 Option	RES	RES	RES	3EDG	MODE	EDG1	EDG0	SLOW	04h
92h	R/W	FANTACH3 Option	RES	RES	RES	3EDG	MODE	EDG1	EDG0	SLOW	04h

These registers become read only when the Lock bit is set. Any further attempts to write to these registers shall have no effect.

Bit[0] SLOW

0= Force tach reading register to FFFFh if number of tach edges detected is greater than 0, but less than programmed number of edges. (default)

1=Force tach reading register to FFFEh if number of tach edges detected is greater than 0, but less than programmed number of edges.

Bit[2:1] The number of edges for tach reading:

00=2 edges

01=3 edges

10=5 edges (default)

11=9 edges

Bit[3] Tachometer Reading Mode

0=mode 1 standard (Default)

1=mode 2 enhanced.

Notes:

- Unused FANTACH inputs must be configured for Mode 1.
- Tach inputs associated with PWM outputs that are configured for high frequency mode must be configured for Mode 1.

Bit[4] 3 Edge Detection (Mode 2 only)

0=Don't ignore first 3 edges (default)

1=Ignore first 3 tachometer edges after guard time

Note: This bit has been added to support a small sampling of fans that emit irregular tach pulses when the PWM transitions 'ON'. Typically, the guard time is sufficient for most fans.

Datasheet

Bit[7:5] Reserved

24.2.41 Registers 94h-96h: PWMx Option Registers

Register Address	Read /Write	Register Name	Bit 7 (MSb)	Bit 6	Bit 5	Bit 4	Bit 3	Bit 2	Bit 1	Bit 0 (LSb)	Default Value
94h	R/W	PWM1 Option	RES	RES	OPP	GRD1	GRD0	SZEN	UPDT1	UPDT0	0Ch
95h	R/W	PWM2 Option	RES	RES	OPP	GRD1	GRD0	SZEN	UPDT1	UPDT0	0Ch
96h	R/W	PWM3 Option	RES	RES	OPP	GRD1	GRD0	SZEN	UPDT1	UPDT0	0Ch

These registers become read only when the Lock bit is set. Any further attempts to write to these registers shall have no effect.

Bits[1:0] Tachs reading registers associated with PWMx are updated: (Mode 2 only)

00=once a second (default)

01=twice a second

1x=every 300msec

Bit[2] Snap to Zero (SZEN)

This bit determines if the PWM output ramps down to OFF or if it is immediately set to zero.

0=Step Down the PWMx output to Off at the programmed Ramp Rate

1=Transition PWMx to Off immediately when the calculated duty cycle is 00h (default)

Bit[4:3] Guard time (Mode 2 only)

00=63 clocks (90kHz clocks ~ 700usec)

01=32 clocks (90kHz clocks ~ 356usec) (default)

10=16 clocks (90kHz clocks ~ 178usec)

11=8 clocks (90kHz clocks ~ 89usec)

Bit[5] Opportunistic Mode Enable

0= Opportunistic Mode Disabled. Update Tach Reading once per PWMx Update Period (see Bits[1:0] in this register)

1=Opportunistic Mode is Enabled. The tachometer reading register is updated any time a valid tachometer reading can be made during the 'on' time of the PWM output signal. If a valid reading is detected prior to the Update cycle, then the Update counter is reset.

Bit[7:6] Reserved

24.2.42 Register 97h: SMSC Test Register

Register Address	Read /Write	Register Name	Bit 7 (MSb)	Bit 6	Bit 5	Bit 4	Bit 3	Bit 2	Bit 1	Bit 0 (LSb)	Default Value
97h	R/W	SMSC Test Register	TST7	TST6	TST5	TST4	TST3	TST2	TST1	TST0	5Ah

These registers become read only when the Lock bit is set. Any further attempts to write to these registers shall have no effect.

This is an SMSC Test Register. Writing to this register may cause unwanted results.

24.2.43 Register 98h:SMSC Test Register

Register Address	Read /Write	Register Name	Bit 7 (MSb)	Bit 6	Bit 5	Bit 4	Bit 3	Bit 2	Bit 1	Bit 0 (LSb)	Default Value
98h	R/W	SMSC Test Register	TST7	TST6	TST5	TST4	TST3	TST2	TST1	TST0	F1h

These registers become read only when the Lock bit is set. Any further attempts to write to these registers shall have no effect.

This is an SMSC Test Register. Writing to this register may cause unwanted results.

24.2.44 Registers 99h-9Ah:Voltage Reading Registers

See [Section 24.2.3, "Registers 20-24h, 99-9Ah: Voltage Reading,"](#) on page 230.

24.2.45 Registers 9B-9EH: Voltage Limit Registers

See PME_STS1.

24.2.46 Register A3h: SMSC Test Register

Register Address	Read /Write	Register Name	Bit 7 (MSb)	Bit 6	Bit 5	Bit 4	Bit 3	Bit 2	Bit 1	Bit 0 (LSb)	Default Value
A3h	R/W	SMSC Test Register	TST7	TST6	TST5	TST4	TST3	TST2	TST1	TST0	00h

This is an SMSC Test Register. Writing to this register may cause unwanted results.

24.2.47 Register A4h: SMSC Test Register

Register Address	Read /Write	Register Name	Bit 7 (MSb)	Bit 6	Bit 5	Bit 4	Bit 3	Bit 2	Bit 1	Bit 0 (LSb)	Default Value
A4h	R	SMSC Test Register	TST7	TST6	TST5	TST4	TST3	TST2	TST1	TST0	02h

This register is an SMSC Test register.

24.2.48 Register A5h: Interrupt Status Register 1 - Secondary

Register Address	Read/ Write	Register Name	Bit 7 (MSb)	Bit 6	Bit 5	Bit 4	Bit 3	Bit 2	Bit 1	Bit 0 (LSb)	Default Value
A5h	R/WC	Interrupt Status 1 - Secondary	INT2 Note 24.19	D2	AMB	D1	5V	VCC	Vccp	2.5V	00h

Note 24.19 This is a read-only bit. Writing '1' to this bit has no effect.

Notes:

- This register is reset to its default value when the PWRGD_PS signal transitions high.
- This is a read/write-to-clear register. Bits[6:4] are cleared on a write of one if the temperature event is no longer active. Writing a zero to these bits has no effect.

See definition of [Register 41h: Interrupt Status Register 1](#) on page 236 for setting and clearing bits.

Datasheet

Note: Only the primary status registers generate an interrupt event.

24.2.49 Register A6h: Interrupt Status Register 2 - Secondary

Register Address	Read/Write	Register Name	Bit 7 (MSb)	Bit 6	Bit 5	Bit 4	Bit 3	Bit 2	Bit 1	Bit 0 (LSb)	Default Value
A6h	R/WC	Interrupt Status Register 2 - Secondary	ERR2	ERR1	RES	FANTA CH3	FANTA CH2	FANTA CH1	RES	12V	00h

Notes:

- This register is reset to its default value when the PWRGD_PS signal transitions high.
- This is a read/write-to-clear register. The status bits in this register are cleared on a write of one if the event causing the interrupt is no longer active. Writing a zero to these bits has no effect.

See definition of [Register 42h: Interrupt Status Register 2 on page 238](#) for setting and clearing bits.

Note: Only the primary status registers generate an interrupt event.

24.2.50 Register A7h: Interrupt Status Register 3 - Secondary

Register Address	Read/Write	Register Name	Bit 7 (MSb)	Bit 6	Bit 5	Bit 4	Bit 3	Bit 2	Bit 1	Bit 0 (LSb)	Default Value
A7h	R/WC	Interrupt Status Register 3- Secondary	RES	RES	RES	RES	RES	RES	VBAT	VTR	00h

Notes:

- This register is reset to its default value when the PWRGD_PS signal transitions high.
- This is a read/write-to-clear register. The status bits in this register are cleared on a write of one if the event causing the interrupt is no longer active. Writing a zero to these bits has no effect.

See definition of [Register 83h: Interrupt Status Register 3 on page 256](#) for setting and clearing bits.

Note: Only the primary status registers generate an interrupt event.

24.2.51 Register ABh: TACH 1-3 Mode Register

Register Address	Read/Write	Register Name	Bit 7 (MSb)	Bit 6	Bit 5	Bit 4	Bit 3	Bit 2	Bit 1	Bit 0 (LSb)	Default Value
ABh	R/W	Tach 1-3 Mode	T1M1	T1M0	T2M1	T2M0	T3M1	T3M0	RES	RES	00h

The following defines the mode control bits:

- bits[7:6]: Tach1 Mode
- bits[5:4]: Tach2 Mode.
- bits[3:2]: Tach3 Mode.
- bits[1:0]: RESERVED.

For bits[7:2], these bits are defined as follows:

- 00=normal operation (default)
- 01=locked rotor mode, active high signal
- 10=locked rotor mode, active low signal
- 11=undefined.

For bits[1:0], these bits are defined as RESERVED. Writes have no affect, reads return 00.

24.2.52 Register ADh: SMSC Test Register

Register Address	Read/Write	Register Name	Bit 7 (MSb)	Bit 6	Bit 5	Bit 4	Bit 3	Bit 2	Bit 1	Bit 0 (LSb)	Default Value
ADh	R	SMSC Test Register	7	6	5	4	3	2	1	0	00h

This is a read-only smsc test register. Writing to this register has no effect.

24.2.53 Registers AE-AFh, B3h: Top Temperature Limit Registers

Register Address	Read/Write	Register Name	Bit 7 (MSb)	Bit 6	Bit 5	Bit 4	Bit 3	Bit 2	Bit 1	Bit 0 (LSb)	Default Value
AEh	R/W	Top Temperature Remote Diode 1 (Zone 1)	7	6	5	4	3	2	1	0	2Dh
AFh	R/W	Top Temperature Remote Diode 2 (Zone 3)	7	6	5	4	3	2	1	0	2Dh
B3h	R/W	Top Temperature Ambient (Zone 2)	7	6	5	4	3	2	1	0	2Dh

Note: These registers are reset to their default values when the powergood_ps signal transitions high.

This register becomes read only when the Lock bit is set. Any further attempts to write to this register shall have no effect.

The Top Temperature Registers define the upper bound of the operating temperature for each zone. If the temperature of the zone exceeds this value, the minimum temperature for the zone can be configured to be adjusted down.

The Top Temperature registers are used as a comparison point for the AMTA feature, to determine if the Low Temp Limit register for a zone should be adjusted down. The Top temp register for a zone is not used if the AMTA feature is not enabled for the zone. The AMTA feature is enabled via the Tmin Adjust Enable register at 0B7h.

24.2.54 Register B4h: Min Temp Adjust Temp RD1, RD2 (Zones 1 & 3)

Register Address	Read/Write	Register Name	Bit 7 (MSb)	Bit 6	Bit 5	Bit 4	Bit 3	Bit 2	Bit 1	Bit 0 (LSb)	Default Value
B4h	R/W	Min Temp Adjust Temp RD1, RD2 (Zones 1&3)	R1AT P1	R1AT P0	R2AT P1	R2AT P0	RES	RES	RES	RES	00h

This register becomes read only when the Lock bit is set. Any further attempts to write to this register shall have no effect.

Bits[7:4] are used to select the temperature adjustment values that are subtracted from the Zone Low temp limit for zones 1 & 3. There is a 2-bit value for each of the remote zones that is used to program the value that is subtracted from the low temp limit temperature register when the temperature reading for the zone reaches the Top Temperature for the AMTA feature. The AMTA feature is enabled via the Tmin Adjust Enable register at B7h.

These bits are defined as follows: ZxATP[1:0]:

- 00=2oC (default)
- 01=4oC
- 10=6oC
- 11=8oC

Datasheet

Note: The Zones are hardwired to the sensors in the following manner:

- R1ATP[1:0] = Zone 1 = Remote Diode 1
- AMATP[1:0] = Zone 2 = Ambient
- R2ATP[1:0] = Zone 3 = Remote Diode 2

24.2.55 Register B5h: Min Temp Adjust Temp and Delay AMB (Zone 2)

Register Address	Read/Write	Register Name	Bit 7 (MSb)	Bit 6	Bit 5	Bit 4	Bit 3	Bit 2	Bit 1	Bit 0 (LSb)	Default Value
B5h	R/W	Min Temp Adjust Temp and Delay (Zone 2)	RES	RES	AMATP1	AMATP0	RES	RES	AMAD1	AMAD0	00h

This register becomes read only when the Lock bit is set. Any further attempts to write to this register shall have no effect.

Bits[5:4] Min Temp Adjust for Ambient Temp Sensor (Zone 2)

See [Register B4h: Min Temp Adjust Temp RD1, RD2 \(Zones 1 & 3\)](#) on page 262 for a definition of the Min Temp Adjust bits.

Bits[1:0] Min Temp Adjust Delay for Ambient Temp Sensor (Zone 2)

See [Register B6h: Min Temp Adjust Delay RD1, RD2 \(ZONE 1 & 3\) Register](#) on page 263 for a definition of the Min Temp Delay bits.

24.2.56 Register B6h: Min Temp Adjust Delay RD1, RD2 (ZONE 1 & 3) Register

Register Address	Read/Write	Register Name	Bit 7 (MSb)	Bit 6	Bit 5	Bit 4	Bit 3	Bit 2	Bit 1	Bit 0 (LSb)	Default Value
B6h	R/W	Min Temp Adjust Temp and Delay RD1, RD2 (Zones 1 & 3)	R1AD1	R1AD0	R2AD1	R2AD0	RES	RES	RES	RES	00h

This register becomes read only when the Lock bit is set. Any further attempts to write to this register shall have no effect.

Bits[7:4] are the bits to program the time delay for subsequently adjusting the low temperature limit value for zones 1&3 once an adjustment is made. These bits are defined as follows: RxAD[1:0]:

00=1min (default)

01=2min

10=3min

11=4min

Note: The Zones are hardwired to the sensors in the following manner:

- R1AD[1:0] = Zone 1 = Remote Diode 1
- AMAD[1:0] = Zone 2 = Ambient
- R2AD[1:0] = Zone 3 = Remote Diode 2

24.2.57 Register B7h: Min Temp Adjust Enable Register

Register Address	Read/Write	Register Name	Bit 7 (MSb)	Bit 6	Bit 5	Bit 4	Bit 3	Bit 2	Bit 1	Bit 0 (LSb)	Default Value
B7h	R/W	Tmin Adjust Enable	RES	RES	RES	RES	TMIN ADJ_ EN2	TMIN ADJ_ EN1	TMIN ADJ_ ENA	TOP_ INT_ EN	00h

This register becomes read only when the Lock bit is set. Any further attempts to write to this register shall have no effect.

This register is used to enable the Automatic Minimum Temperature Adjustment (AMTA) feature for each zone. AMTA allows for an adjustment of the low temp limit temperature register for each zone when the current temperature for the zone exceeds the Top Temperature. Bits[3:1] are used to enable an adjustment of the low temp limit for each of zones 1-3.

This register also contains the bit (TOP_INT_EN) to enable an interrupt to be generated anytime the top temp for any zone is exceeded. This interrupt is generated based on a bit in the Top Temp Exceeded status register (0B8h) being set. Note that the INT_EN bit (register 7Ch) must also be set for an interrupt to be generated on the THERM pin.

Note: The Zones are hardwired to the sensors in the following manner:

- TMIN_ADJ_EN1 = Zone 1 = Remote Diode 1
- TMIN_ADJ_ENA = Zone 2 = Ambient
- TMIN_ADJ_EN2 = Zone 3 = Remote Diode 2

24.2.58 Register B8h: Top Temp Exceeded Status Register

Register Address	Read/Write	Register Name	Bit 7 (MSb)	Bit 6	Bit 5	Bit 4	Bit 3	Bit 2	Bit 1	Bit 0 (LSb)	Default Value
B8h	R/WC	Top Temp Exceeded Status	RES	RES	RES	RES	RES	STS2	STS1	STSA	00h

Note: Each bit in this register is cleared on a write of 1 if the event is not active.

Note: This register is reset to its default value when the PWRGD_PS signal transitions high.

The Top Temp Exceeded Status Register bits are automatically set by the device whenever the temperature value in the reading register for a zone exceeds the value in the Top Temperature register for the zone.

This register holds a bit set until the bit is written to 1 by software. The contents of this register are cleared (set to 0) automatically by the device after it is written by software, if the temperature no longer exceeds the value in the Top Temperature register for the zone. Once set, the Status bits remain set until written to 1, even if the if the temperature no longer exceeds the value in the Top Temperature register for the zone.

Note: If a bit is set in this register, an interrupt can be generated if the TOP_INT_EN bit (register B7h) and, for the nHWM_INT pin to go active, the INT_EN bit (7Ch) is set.

Datasheet

24.2.59 Register BAh: SMSC Reserved Register

Register Address	Read/Write	Register Name	Bit 7 (MSb)	Bit 6	Bit 5	Bit 4	Bit 3	Bit 2	Bit 1	Bit 0 (LSb)	Default Value
BAh	R/W	SMSC Reserved	RES	RES	RES	RES	RES	RES	RES	RES	03h

This is an SMSC Reserved bit. Writing this bit to a value different than the default value may cause unwanted results.

24.2.60 Register BBh: SMSC Reserved Register

Register Address	Read/Write	Register Name	Bit 7 (MSb)	Bit 6	Bit 5	Bit 4	Bit 3	Bit 2	Bit 1	Bit 0 (LSb)	Default Value
BBh	R	SMSC Reserved	7	6	5	4	3	2	1	0	00h

This is an SMSC Reserved bit. Writing this bit to a value different than the default value may cause unwanted results.

24.2.61 Register 0BDh: SMSC Reserved Register

Register Address	Read/Write	Register Name	Bit 7 (MSb)	Bit 6	Bit 5	Bit 4	Bit 3	Bit 2	Bit 1	Bit 0 (LSb)	Default Value
BDh	R	SMSC Reserved	7	6	5	4	3	2	1	0	N/A

This is an SMSC Reserved bit. Writing this bit to a value different than the default value may cause unwanted results.

24.2.62 Register BFh: SMSC Reserved Register

Register Address	Read/Write	Register Name	Bit 7 (MSb)	Bit 6	Bit 5	Bit 4	Bit 3	Bit 2	Bit 1	Bit 0 (LSb)	Default Value
BFh	R/W	SMSC Reserved	RES	RES	RES	RES	RES	RES	RES	RES	00h

This is an SMSC Reserved bit. Writing this bit to a value different than the default value may cause unwanted results.

24.2.63 Register C0h: SMSC Reserved Register

Register Address	Read/Write	Register Name	Bit 7 (MSb)	Bit 6	Bit 5	Bit 4	Bit 3	Bit 2	Bit 1	Bit 0 (LSb)	Default Value
C0h	R/W	SMSC Reserved	RES	RES	RES	RES	RES	RES	RES	RES	00h

This is an SMSC Reserved bit. Writing this bit to a value different than the default value may cause unwanted results.

24.2.64 Register C1h: SMSC Reserved Register

Register Address	Read /Write	Register Name	Bit 7 (MSb)	Bit 6	Bit 5	Bit 4	Bit 3	Bit 2	Bit 1	Bit 0 (LSb)	Default Value
C1h	R/W	Thermtrip Control	RES	RES	RES	RES	RES	RES	THERM TRIP_CTRL	RES	01h

THERMTRIP_CTRL: Bit 1 in the Thermtrip Control register. May be enabled to assert the Thermtrip# pin if programmed limits are exceeded as indicated by the Thermtrip Status register 1=enable, 0=disable (default)

24.2.65 Registers C4-C5, C9h: THERMTRIP Temperature Limit Zone Registers

Register Address	Read/ Write	Register Name	Bit 7 (MSb)	Bit 6	Bit 5	Bit 4	Bit 3	Bit 2	Bit 1	Bit 0 (LSb)	Default Value
C4h	R/W	THERMTRIP Temp Limit ZONE 1 (Remote Diode 1)	7	6	5	4	3	2	1	0	7Fh
C9h	R/W	THERMTRIP Temp Limit ZONE 2 (Ambient)	7	6	5	4	3	2	1	0	7Fh
C5h	R/W	THERMTRIP Temp Limit ZONE 3 (Remote Diode 2)	7	6	5	4	3	2	1	0	7Fh

These registers become read only when the Lock bit is set. Any further attempts to write to these registers shall have no effect.

The nTHERMTRIP pin can be configured to assert when one of the temperature zones is above its associated THERMTRIP temperature limit (THERMTRIP Temp Limit ZONES 1-3). The THERMTRIP temperature limit is a separate limit register from the high limit used for setting the interrupt status bits for each zone.

The THERMTRIP Temp Limit ZONE 1-3 registers represent the upper temperature limit for asserting nTHERMTRIP pin for each zone. These registers are defined as follows:

If the monitored temperature for the zone exceeds the value set in the associated THERMTRIP Temp Limit ZONE 1-3 registers, the corresponding bit in the THERMTRIP status register will be set. The nTHERMTRIP pin may or may not be set depending on the state of the associated enable bits (in the THERMTRIP Output Enable register).

Note: The zone must exceed the limits set in the associated THERMTRIP Temp Limit ZONE 1-3 register for two successive monitoring cycles in order for the nTHERMTRIP pin to go active (and for the associated status bit to be set).

24.2.66 Register CAh: THERMTRIP Status Register

Register Address	Read/ Write	Register Name	Bit 7 (MSb)	Bit 6	Bit 5	Bit 4	Bit 3	Bit 2	Bit 1	Bit 0 (LSb)	Default Value
CAh	R/WC	THERMTRIP Status	RES	RES	RES	RES	RES	RD 2	RD 1	AMB	00h

Note: Each bit in this register is cleared on a write of 1 if the event is not active.

Note: This register is reset to its default value when the PWRGD_PS signal transitions high.

This register holds a bit set until the bit is written to 1 by software. The contents of this register are cleared (set to 0) automatically by the device after it is written by software, if the nTHERMTRIP pin is no longer active. Once set, the Status bits remain set until written to 1, even if the nTHERMTRIP pin is no longer active.

Datasheet

Bits[2:0] THERMTRIP zone status bits (one bit per zone). A status bit is set to '1' if the associated zone temp exceeds the associated THERMTRIP Temp Limit register value.

24.2.67 Register CBh: THERMTRIP Output Enable Register

Register Address	Read/Write	Register Name	Bit 7 (MSb)	Bit 6	Bit 5	Bit 4	Bit 3	Bit 2	Bit 1	Bit 0 (LSb)	Default Value
CBh	R/W	THERMTRIP Output Enable	RES	RES	RES	RES	RES	RD2	RD1	AMB	00h

These registers become read only when the Lock bit is set. Any further attempts to write to these registers shall have no effect.

Bits[2:0] in THERMTRIP Output Enable register, THERMTRIP output enable bits (one bit per zone). Each zone may be individually enabled to assert the nTHERMTRIP pin if the zone temperature reading exceeds the associated THERMTRIP Temp Limit register value. 1=enable, 0=disable (default)

24.2.68 Register CEh: SMSC Reserved Register

Register Address	Read/Write	Register Name	Bit 7 (MSb)	Bit 6	Bit 5	Bit 4	Bit 3	Bit 2	Bit 1	Bit 0 (LSb)	Default Value
CEh	R/W		RES	RES	RES	RES	RES	RD2_INT_EN	RD1_INT_EN	AMB_INT_EN	00h

24.2.69 Registers D1,D6,DBh: PWM Max Segment Registers

Register Address	Read/Write	Register Name	Bit 7 (MSb)	Bit 6	Bit 5	Bit 4	Bit 3	Bit 2	Bit 1	Bit 0 (LSb)	Default Value
0D1h	R/W	PWM1 Max	7	6	5	4	3	2	1	0	FFh
0D6h	R/W	PWM2 Max	7	6	5	4	3	2	1	0	FFh
0DBh	R/W	PWM3 Max	7	6	5	4	3	2	1	0	FFh

These registers become read only when the Lock bit is set. Any further attempts to write to these registers shall have no effect.

Registers 0D1h, 0D6h and 0DBh are used to program the Max PWM duty cycle for the fan function for each PWM.

24.2.70 Register E0h: Enable LSbs for Auto Fan

Register Address	Read/Write	Register Name	Bit 7 (MSb)	Bit 6	Bit 5	Bit 4	Bit 3	Bit 2	Bit 1	Bit 0 (LSb)	Default Value
E0h	R/W	Enable LSbs for AutoFan	RES	RES	PWM3_n1	PWM3_n0	PWM2_n1	PWM2_n0	PWM1_n1	PWM1_n0	00h

Bits[7:6] Reserved

Bits[5:4] PWM3_n[1:0]

Bits[3:2] PWM2_n[1:0]

Bits[1:0] PWM1_n[1:0]

The PWMx_n[1:0] configuration bits allow the autofan control logic to utilize the extended resolution bits in the temperature reading. Increasing the precision reduces the programmable temperature range that can be used to control the PWM outputs. For a description of the programmable temperature ranges see [Registers 5F-61h: Zone Temperature Range, PWM Frequency on page 244](#).

Note: Increasing the precision does not limit the range of temperature readings supported. The active region for the autofan control is bound by the Minimum Zone Limit + Range, where the Minimum Zone Limit can be any integer value from -127 to +127 degrees.

Table 24.18 Programming Options for the PWMX_N[1:0] Bits

PWMX_N[1:0]	DEGREE OF RESOLUTION PER LSB USED IN AUTOFAN	MAX THEORETICAL TEMPERATURE RANGE SUPPORTED	MAX PROGRAMMABLE TEMPERATURE RANGE SUPPORTED
00	1	255	80
01	0.5	128.5	80
10	0.25	64.75	53.33
11	Reserved	Reserved	Reserved

Register E9-EEh: SMSC Test Registers

Register Address	Read /Write	Register Name	Bit 7 (MSb)	Bit 6	Bit 5	Bit 4	Bit 3	Bit 2	Bit 1	Bit 0 (LSb)	Default Value
E9h	R/W	SMSC Test Register	TST7	TST6	TST5	TST4	TST3	TST2	TST1	TST0	00h
EAh	R/W	SMSC Test Register	TST7	TST6	TST5	TST4	TST3	TST2	TST1	TST0	00h
EBh	R/W	SMSC Test Register	TST7	TST6	TST5	TST4	TST3	TST2	TST1	TST0	00h
ECh	R/W	SMSC Test Register	TST7	TST6	TST5	TST4	TST3	TST2	TST1	TST0	00h
EDh	R/W	SMSC Test Register	TST7	TST6	TST5	TST4	TST3	TST2	TST1	TST0	00h
EEh	R/W	SMSC Test Register	TST7	TST6	TST5	TST4	TST3	TST2	TST1	TST0	00h

These are SMSC Test Registers. Writing to these registers may cause unwanted results.

24.2.71 Register FFh: SMSC Test Register

Register Address	Read /Write	Register Name	Bit 7 (MSb)	Bit 6	Bit 5	Bit 4	Bit 3	Bit 2	Bit 1	Bit 0 (LSb)	Default Value
FFh	R	SMSC Test Register	TST7	TST6	TST5	TST4	TST3	TST2	TST1	TST0	N/A

This register is an SMSC Test register.

Chapter 25 Config Registers

The Configuration of the SCH311X is very flexible and is based on the configuration architecture implemented in typical Plug-and-Play components. The SCH311X is designed for motherboard applications in which the resources required by their components are known. With its flexible resource allocation architecture, the SCH311X allows the BIOS to assign resources at POST.

SYSTEM ELEMENTS

Primary Configuration Address Decoder

After a PCI Reset or Vcc Power On Reset the SCH311X is in the Run Mode with all logical devices disabled. The logical devices may be configured through two standard Configuration I/O Ports (INDEX and DATA) by placing the SCH311X into Configuration Mode.

The BIOS uses these configuration ports to initialize the logical devices at POST. The INDEX and DATA ports are only valid when the SCH311X is in Configuration Mode.

Strap options must be added to allow four Configuration Register Base Address options: 0x002E, 0x004E, 0x162E, or 0x164E. At the deasserting edge of PCIRST# or VCC POR the nRTS1/SYSOPT0 pin is latched to determine the configuration base address:

- 0 = Index Base I/O Address bits A[7:0]= 0x2E
- 1 = Index Base I/O Address bits A[7:0]= 0x4E

At the deasserting edge of PCIRST# or VCC POR the nDTR1/SYSOPT1 pin is latched to determine the configuration base address:

- 0 = Index Base I/O Address bits A[15:8]= 0x16;
- 1 = Index Base I/O Address bits A[15:8]= 0x00

The above strap options will allow the Configuration Access Ports (CONFIG PORT, the INDEX PORT, and DATA PORT) to be controlled by the nRTS1/SYSOPT0 and nDTR1/SYSOPT1 pins and by the Configuration Port Base Address registers at offset 0x26 and 0x27. The configuration base address at power-up is determined by the SYSOPT strap option. The SYSOPT strap option is latched state of the nRTS1/SYSOPT0 and nDTR1/SYSOPT1 pins at the deasserting edge of PCIRST#. The nRTS1/SYSOPT0 pin determines the lower byte of the Base Address and the nDTR1/SYSOPT1 pin determines the upper byte of the Base Address. The following table summarizes the Base Configuration address selected by the SYSOPT strap option.

Table 25.1 SYSOPT Strap Option Configuration Address Select

SYSOPT1	SYSOPT0	DEFAULT CONFIG PORT/ INDEX PORT ADDRESS	DATA PORT
1	0	0x002E	INDEX PORT + 1
1	1	0x004E	
0	0	0x162E	
0	1	0x164E	

APPLICATION NOTE: The nRTS1/SYSOPT0 and the nDTR1/SYSOPT1 pins requires external pullup/pulldown resistors to set the default base I/O address for configuration to 0x002E, 0x004E, 0x162E, or 0x164E.

Note: An external pull-down resistor is required for the base IO address to be 0x02E for configuration. An external pull-up resistor is required to move the base IO address for configuration to 0x04E.

The INDEX and DATA ports are effective only when the chip is in the Configuration State.

Note 25.1 The configuration port base address can be relocated through CR26 and CR27.

Entering the Configuration State

The device enters the Configuration State when the following Config Key is successfully written to the CONFIG PORT.

Config Key = <0x55>

Exiting the Configuration State

The device exits the Configuration State when the following Config Key is successfully written to the CONFIG PORT.

Config Key = <0xAA>

CONFIGURATION SEQUENCE

To program the configuration registers, the following sequence must be followed:

1. Enter Configuration Mode
2. Configure the Configuration Registers
3. Exit Configuration Mode.

Enter Configuration Mode

To place the chip into the Configuration State the Config Key is sent to the chip's CONFIG PORT. The config key consists of 0x55 written to the CONFIG PORT. Once the configuration key is received correctly the chip enters into the Configuration State (The auto Config ports are enabled).

Configuration Mode

The system sets the logical device information and activates desired logical devices through the INDEX and DATA ports. In configuration mode, the INDEX PORT is located at the CONFIG PORT address and the DATA PORT is at INDEX PORT address + 1.

The desired configuration registers are accessed in two steps:

1. Write the index of the Logical Device Number Configuration Register (i.e., 0x07) to the INDEX PORT and then write the number of the desired logical device to the DATA PORT
2. Write the address of the desired configuration register within the logical device to the INDEX PORT and then write or read the configuration register through the DATA PORT.

Note: If accessing the Global Configuration Registers, step (a) is not required.

Exit Configuration Mode

To exit the Configuration State the system writes 0xAA to the CONFIG PORT. The chip returns to the RUN State.

Note: Only two states are defined (Run and Configuration). In the Run State the chip will always be ready to enter the Configuration State.

Programming Example

The following is an example of a configuration program in Intel 8086 assembly language.

```
-----  
; ENTER CONFIGURATION MODE |  
-----  
MOV DX, 02EH  
MOV AX, 055H  
OUT DX, AL  
-----  
; CONFIGURE REGISTER CRE0, |
```

Datasheet

```

; LOGICAL DEVICE 8
;-----\
MOV DX,02EH
MOV AL,07H
OUT DX,AL ;Point to LD# Config Reg
MOV DX,02FH
MOV AL, 08H
OUT DX,AL;Point to Logical Device 8
;
MOV DX,02EH
MOV AL,E0H
OUT DX,AL; Point to CRE0
MOV DX,02fH
MOV AL,02H
OUT DX,AL; Update CRE0
;-----\
; EXIT CONFIGURATION MODE
;-----\
MOV DX,02EH
MOV AX,0AAH
OUT DX,AL

```

Notes: :

- SOFT RESET: Bit 0 of Configuration Control register set to one.
- All host accesses are blocked for 500µs after Vcc POR (See [Figure 29.1 Power-Up Timing on page 348.](#))

25.1 Configuration Registers

The following table summarizes the logical device allocation for the different varieties of SCH311X devices.

Table 25.2 SCH311X Logical Device Summary

LOGICAL DEVICE	SCH3112	SCH3114	SCH3116
0	FDD	FDD	FDD
1	RESERVED	RESERVED	RESERVED
2	RESERVED	RESERVED	RESERVED
3	PARALLEL PORT	PARALLEL PORT	PARALLEL PORT
4	SERIAL PORT1	SERIAL PORT1	SERIAL PORT1
5	SERIAL PORT 2	SERIAL PORT 2	SERIAL PORT 2
6	RESERVED	RESERVED	RESERVED
7	KEYBOARD	KEYBOARD	KEYBOARD
8	RESERVED	RESERVED	RESERVED
9	RESERVED	RESERVED	RESERVED
Ah	RUNTIME REGISTERS	RUNTIME REGISTERS	RUNTIME REGISTERS
Bh	RESERVED	SERIAL PORT3	SERIAL PORT3
Ch	RESERVED	SERIAL PORT 4	SERIAL PORT 4

Table 25.2 SCH311X Logical Device Summary (continued)

LOGICAL DEVICE	SCH3112	SCH3114	SCH3116
Dh	RESERVED	RESERVED	SERIAL PORT 5
Eh	RESERVED	RESERVED	SERIAL PORT 6
Fh	RESERVED	RESERVED	RESERVED

Table 25.3 Configuration Register Summary

INDEX	TYPE	PCI RESET	VCC POR	VTR POR	SOFT RESET	CONFIGURATION REGISTER
GLOBAL CONFIGURATION REGISTERS						
0x02	W	0x00	0x00	0x00	-	Config Control
0x03	R	-	-	-	-	Reserved – reads return 0
0x07	R/W	0x00	0x00	0x00	0x00	Logical Device Number
0x20	R	0x7c-0x7F	0x7c-0x7F	0x7c-0x7F	0x7c-0x7F	Device ID - hard wired SCH3112 - 0x7C SCH3114 - 0x7D Reserved - 0x7E SCH3116 - 0x7F
0x19	R/W	-	0x00	0x00	-	TEST8
0x21	R	Current Revision				Device Rev - hard wired
0x22	R/W	0x00	0x00	0x00	0x00	Power Control
0x23	R/W (PME_ST S1)	0x00	0x00	0x00	-	Reserved
0x24	R/W	0x44	0x44	0x44	-	OSC
0x25	R/W	-	0x00	0x00	-	TEST9
0x26	R/W	See PME_ST S1	-	-	-	Configuration Port Address Byte 0 (Low Byte)
0x27	R/W	See PME_ST S1	-	-	-	Configuration Port Address Byte 1 (High Byte)
0x28	R	-	-	-	-	Reserved
0x29	R/W	-	0x00	0x00	-	TEST
0x2A	R/W	-	0x00	0x00	-	TEST 6
0x2B	R/W	-	0x00	0x00	-	TEST 4
0x2C	R/W	-	0x00	0x00	-	TEST 5
0x2D	R/W	-	0x00	0x00	-	TEST 1
0x2E	R/W	-	0x00	0x00	-	TEST 2

Datasheet

Table 25.3 Configuration Register Summary (continued)

INDEX	TYPE	PCI RESET	VCC POR	VTR POR	SOFT RESET	CONFIGURATION REGISTER
0x2F	R/W	-	0x00	0x00	-	TEST 3
LOGICAL DEVICE 0 CONFIGURATION REGISTERS (FDD)						
0x30	R/W	0x00	0x00	0x00	0x00	Activate
0x60	R/W	0x03	0x03	0x03	0x03	Primary Base I/O Address High Byte
0x61	R/W	0xF0	0xF0	0xF0	0xF0	Primary Base I/O Address Low Byte
0x70	R/W	0x06	0x06	0x06	0x06	Primary Interrupt Select
0x74	R/W	0x02	0x02	0x02	0x02	DMA Channel Select
0xF0	R/W	0x0E	0x0E	0x0E	-	FDD Mode Register
0xF1	R/W	0x00	0x00	0x00	-	FDD Option Register
0xF2	R/W	0xFF	0xFF	0xFF	-	FDD Type Register
0xF4	R/W	0x00	0x00	0x00	-	FDD0
0xF5	R/W	0x00	0x00	0x00	-	FDD1
LOGICAL DEVICE 1 CONFIGURATION REGISTERS (RESERVED)						
LOGICAL DEVICE 2 CONFIGURATION REGISTERS (RESERVED)						
LOGICAL DEVICE 3 CONFIGURATION REGISTERS (PARALLEL PORT)						
0x30	R/W	0x00	0x00	0x00	0x00	Activate
0x60	R/W	0x00	0x00	0x00	0x00	Primary Base I/O Address High Byte
0x61	R/W	0x00	0x00	0x00	0x00	Primary Base I/O Address Low Byte
0x70	R/W	0x00	0x00	0x00	0x00	Primary Interrupt Select
0x74	R/W	0x04	0x04	0x04	0x04	DMA Channel Select
0xF0	R/W	0x3C	0x3C	0x3C	-	Parallel Port Mode Register
0xF1	R/W	0x00	0x00	0x00	-	Parallel Port Mode Register 2
LOGICAL DEVICE 4 CONFIGURATION REGISTERS (SERIAL PORT 1)						
0x30	R/W	0x00	0x00	0x00	0x00	Activate Note 25.2
0x60	R/W	0x00	0x00	0x00	0x00	Primary Base I/O Address High Byte
0x61	R/W	0x00	0x00	0x00	0x00	Primary Base I/O Address Low Byte
0x70	R/W	0x00	0x00	0x00	0x00	Primary Interrupt Select
0xF0	R/W	0x00	0x00	0x00	-	Serial Port 1 Mode Register

Table 25.3 Configuration Register Summary (continued)

INDEX	TYPE	PCI RESET	VCC POR	VTR POR	SOFT RESET	CONFIGURATION REGISTER
LOGICAL DEVICE 5 CONFIGURATION REGISTERS (SERIAL PORT 2)						
0x30	R/W	0x00	0x00	0x00	0x00	Activate Note 25.2
0x60	R/W	0x00	0x00	0x00	0x00	Primary Base I/O Address High Byte
0x61	R/W	0x00	0x00	0x00	0x00	Primary Base I/O Address Low Byte
0x70	R/W	0x00	0x00	0x00	0x00	Primary Interrupt Select
0xF0	R/W	0x00	0x00	0x00	-	Serial Port 2 Mode Register
0xF1	R/W	0x02	0x02	0x02	-	IR Options Register
0xF2	R/W	0x03	0x03	0x03	-	IR Half Duplex Timeout
LOGICAL DEVICE 6 CONFIGURATION REGISTERS (RESERVED)						
LOGICAL DEVICE 7 CONFIGURATION REGISTERS (KEYBOARD)						
0x30	R/W	0x00	0x00	0x00	0x00	Activate
0x70	R/W	0x00	0x00	0x00	0x00	Primary Interrupt Select (Keyboard)
0x72	R/W	0x00	0x00	0x00	0x00	Secondary Interrupt Select (Mouse)
0xF0	R/W	0x00	0x00	0x00	-	KRESET and GateA20 Select
LOGICAL DEVICE 8 CONFIGURATION REGISTERS (RESERVED)						
LOGICAL DEVICE 9 CONFIGURATION REGISTERS (RESERVED)						
LOGICAL DEVICE A CONFIGURATION REGISTERS (RUNTIME REGISTERS)						
0x30	R/W	0x00	0x00	0x00	0x00	Activate
0x60	R/W	0x00	0x00	0x00	0x00	Primary Base I/O Address High Byte
0x61	R/W	0x00	0x00	0x00	0x00	Primary Base I/O Address Low Byte
0x62	R/W	0x00	0x00	0x00	0x00	Secondary Base I/O Address High Byte
0x63	R/W	0x00	0x00	0x00	0x00	Secondary Base I/O Address Low Byte
0XF0	R/W	-	-	0X00	-	CLOCKI32
0xF1	R/W	0x00	0x00	0x00	0x00	FDC on PP Mode Register
0XF2	PME_ST S1	0x04	0x04	0x04	-	Security Key Control Register

Table 25.3 Configuration Register Summary (continued)

INDEX	TYPE	PCI RESET	VCC POR	VTR POR	SOFT RESET	CONFIGURATION REGISTER
LOGICAL DEVICE B CONFIGURATION REGISTERS (SERIAL PORT 3) SCH3114, SCH3116 DEVICES ONLY RESERVED IN SCH3112 DEVICE						
0x30	R/W	0x00	0x00	0x00	0x00	Activate Note 25.2
0x60	R/W	0x00	0x00	0x00	0x00	Primary Base I/O Address High Byte
0x61	R/W	0x00	0x00	0x00	0x00	Primary Base I/O Address Low Byte
0x70	R/W	0x00	0x00	0x00	0x00	Primary Interrupt Select
0xF0	R/W	0x00	0x00	0x00	-	Serial Port 3 Mode Register
LOGICAL DEVICE C CONFIGURATION REGISTERS (SERIAL PORT 4) SCH3114, SCH3116 DEVICES ONLY RESERVED IN SCH3112 DEVICE						
0x30	R/W	0x00	0x00	0x00	0x00	Activate Note 25.2
0x60	R/W	0x00	0x00	0x00	0x00	Primary Base I/O Address High Byte
0x61	R/W	0x00	0x00	0x00	0x00	Primary Base I/O Address Low Byte
0x70	R/W	0x00	0x00	0x00	0x00	Primary Interrupt Select
0xF0	R/W	0x00	0x00	0x00	-	Serial Port 4 Mode Register
LOGICAL DEVICE D CONFIGURATION REGISTERS (SERIAL PORT 5) SCH3116 DEVICE ONLY RESERVED IN SCH3112 AND SCH3114 DEVICES						
0x30	R/W	0x00	0x00	0x00	0x00	Activate Note 25.2
0x60	R/W	0x00	0x00	0x00	0x00	Primary Base I/O Address High Byte
0x61	R/W	0x00	0x00	0x00	0x00	Primary Base I/O Address Low Byte
0x70	R/W	0x00	0x00	0x00	0x00	Primary Interrupt Select
0xF0	R/W	0x00	0x00	0x00	-	Serial Port 5 Mode Register
LOGICAL DEVICE E CONFIGURATION REGISTERS (SERIAL PORT 6) SCH3116 DEVICE ONLY RESERVED IN SCH3112 AND SCH3114 DEVICES						
0x30	R/W	0x00	0x00	0x00	0x00	Activate Note 25.2
0x60	R/W	0x00	0x00	0x00	0x00	Primary Base I/O Address High Byte
0x61	R/W	0x00	0x00	0x00	0x00	Primary Base I/O Address Low Byte
0x70	R/W	0x00	0x00	0x00	0x00	Primary Interrupt Select

Table 25.3 Configuration Register Summary (continued)

INDEX	TYPE	PCI RESET	VCC POR	VTR POR	SOFT RESET	CONFIGURATION REGISTER
0xF0	R/W	0x00	0x00	0x00	-	Serial Port 6 Mode Register
LOGICAL DEVICE F CONFIGURATION REGISTERS (RESERVED)						

Note 25.2 Serial ports 1 and 2 may be placed in the powerdown mode by clearing the associated activate bit located at CR30 or by clearing the associated power bit located in the Power Control register at CR22. Serial ports 3,4,5,6 (if available) may be placed in the powerdown mode by clearing the associated activate bit located at CR30. When in the powerdown mode, the serial port outputs are tristated. In cases where the serial port is multiplexed as an alternate function, the corresponding output will only be tristated if the serial port is the selected alternate function.

25.1.1 Global Config Registers

The chip-level (global) registers lie in the address range [0x00-0x2F]. The design MUST use all 8 bits of the ADDRESS Port for register selection. All unimplemented registers and bits ignore writes and return zero when read.

The INDEX PORT is used to select a configuration register in the chip. The DATA PORT is then used to access the selected register. These registers are accessible only in the Configuration Mode.

Table 25.4 Chip-Level (Global) Configuration Registers

REGISTER	ADDRESS	DESCRIPTION
CHIP (GLOBAL) CONTROL REGISTERS		
	0x00 - 0x01	Reserved - Writes are ignored, reads return 0.
Config Control Default = 0x00 on VCC POR, VTR POR and PCI RESET	0x02 W	The hardware automatically clears this bit after the write, there is no need for software to clear the bits. Bit 0 = 1: Soft Reset. Refer to the Table 25.3, "Configuration Register Summary," on page 272 for the soft reset value for each register.
	0x03 - 0x06	Reserved - Writes are ignored, reads return 0.
Logical Device # Default = 0x00 on VCC POR, VTR POR, SOFT RESET and PCI RESET	0x07 R/W	A write to this register selects the current logical device. This allows access to the control and configuration registers for each logical device. Note: The Activate command operates only on the selected logical device.
Reserved	0x08 - 0x18, 0x1A-0x1F	Reserved - Writes are ignored, reads return 0.
CHIP-LEVEL, SMSC DEFINED		

Datasheet

Table 25.4 Chip-Level (Global) Configuration Registers (continued)

REGISTER	ADDRESS	DESCRIPTION
Device ID - Hard wired Default = 0x7C on VCC POR, VTR POR, SOFT RESET and PCI RESET	0x20 R	A read only register which provides device identification.
Device Rev Hard wired = Current Revision	0x21 R	A read only register which provides device revision information. Bits[7:0] = current revision when read.
Power Control Default = 0x00 on VCC POR, VTR POR, SOFT RESET and PCI RESET	0x22 R/W	Bit[0] FDC Power Bit[1] Reserved Bit[2] Reserved Bit[3] Parallel Port Power Bit[4] Serial Port 1 Power Bit[5] Serial Port 2 Power Bit[6] Reserved Bit[7] Reserved 0: Power Off or Disabled 1: Power On or Enabled
Reserved Default = 0x00 on VCC POR, VTR POR and PCI RESET	0x23 R/W	Reserved. This is a read/write register. Writing to this register may cause unwanted results.
OSC Default = 0x44, on on VCC POR, VTR POR and PCI RESET	0x24 R/W	Bit[0] Reserved Bit [1] PLL Control = 0 PLL is on (backward Compatible) = 1 PLL is off Bits[3:2] OSC = 01 Osc is on, BRG clock is on. = 10 Same as above (01) case. = 00 Osc is on, BRG Clock Enabled. = 11 Osc is off, BRG clock is disabled. Bit [5:4] Reserved, set to zero Bit [6] 16-Bit Address Qualification = 0 12-Bit Address Qualification = 1 16-Bit Address Qualification Note: For normal operation, bit 6 should be set. Bit[7] Reserved
Configuration Address Byte 0 Default =0x002E (Sysopt01=10) =0x004E (Sysopt01=11) on VCC POR and PCI RESET	0x26	Bit[7:1] Configuration Address Bits [7:1] Bit[0] = 0 (Note 25.3)
Configuration Address Byte 1 Default =0x162E (Sysopt01=00) =0x164E (Sysopt01=01) on VCC POR and PCI RESET	0x27	Bit[7:0] Configuration Address Bits [15:8] (Note 25.3)

Table 25.4 Chip-Level (Global) Configuration Registers (continued)

REGISTER	ADDRESS	DESCRIPTION
Default = 0x00 on VCC POR, SOFT RESET and PCI RESET	0x28	Bits[7:0] Reserved - Writes are ignored, reads return 0.

Note 25.3 To allow the selection of the configuration address to a user defined location, these Configuration Address Bytes are used. There is no restriction on the address chosen, except that A0 is 0, that is, the address must be on an even byte boundary. As soon as both bytes are changed, the configuration space is moved to the specified location with no delay (**Note:** Write byte 0, then byte 1; writing CR27 changes the base address).

The configuration address is only reset to its default address upon a PCI Reset or Vcc POR.

Note: The default configuration address is either 02Eh or 04Eh, as specified by the SYSOPT pin.

25.1.2 Test Registers

The following test registers are used in the SCH311X devices.

Table 25.5 Test Register Summary

TEST 8 Default = 0x00, on VCC POR and VTR POR	0x19 R/W	Test Modes: Reserved for SMSC. Users should not write to this register, may produce undesired results.
TEST 9 Default = 0x00, on VCC POR and VTR POR	0x25 R/W	Test Modes: Reserved for SMSC. Users should not write to this register, may produce undesired results.
TEST Default = 0x00 Note on VTR_POR BIT0/7 are reset BIT1-6 reset on TST_PORB from resgen block	0x29 R/W	Test Modes: Reserved for SMSC. Users should not write to this register, may produce undesired results.
TEST 6 Default = 0x00, on VCC POR and VTR POR	0x2A R/W	Test Modes: Reserved for SMSC. Users should not write to this register, may produce undesired results.
TEST 4 Default = 0x00, on VCC POR and VTR POR	0x2B R/W	Test Modes: Reserved for SMSC. Users should not write to this register, may produce undesired results.
TEST 5 Default = 0x00, on VCC POR and VTR POR	0x2C R/W	Test Modes: Reserved for SMSC. Users should not write to this register, may produce undesired results.

Datasheet

Table 25.5 Test Register Summary (continued)

TEST 1 Default = 0x00, on VCC POR and VTR POR	0x2D R/W	Test Modes: Reserved for SMSC. Users should not write to this register, may produce undesired results.
TEST 2 Default = 0x00, on VCC POR and VTR POR	0x2E R/W	Test Modes: Reserved for SMSC. Users should not write to this register, may produce undesired results.
TEST 3 Default = 0x00, on VCC POR and VTR POR	0x2F R/W	Test Modes: Reserved for SMSC. Users should not write to this register, may produce undesired results.

LOGICAL DEVICE CONFIGURATION/CONTROL REGISTERS [0X30-0XFF]

Used to access the registers that are assigned to each logical unit. This chip supports six logical units and has eight sets of logical device registers. The eight logical devices are Floppy, Parallel, Serial 1, Serial 2, Keyboard Controller, and Runtime Registers. A separate set (bank) of control and configuration registers exists for each logical device and is selected with the Logical Device # Register (0x07).

The INDEX PORT is used to select a specific logical device register. These registers are then accessed through the DATA PORT.

The Logical Device registers are accessible only when the device is in the Configuration State. The logical register addresses are shown in [Table 25.6](#).

Table 25.6 Logical Device Registers

LOGICAL DEVICE REGISTER	ADDRESS	DESCRIPTION
Activate (Note 25.4) Default = 0x00 on VCC POR, VTR POR, PCI RESET and SOFT RESET	(0x30)	Bits[7:1] Reserved, set to zero. Bit[0] = 1 Activates the logical device currently selected through the Logical Device # register. = 0 Logical device currently selected is inactive
Logical Device Control	(0x31-0x37)	Reserved – Writes are ignored, reads return 0.
Logical Device Control	(0x38-0x3F)	Vendor Defined - Reserved - Writes are ignored, reads return 0.
Memory Base Address	(0x40-0x5F)	Reserved – Writes are ignored, reads return 0.
I/O Base Address (Note 25.5) (see Table 25.7 , “Base I/O Range for Logical Devices,” on page 281) Default = 0x00 on VCC POR, VTR POR, PCI RESET and SOFT RESET	(0x60-0x6F) 0x60,2,... = addr[15:8] 0x61,3,... = addr[7:0]	Registers 0x60 and 0x61 set the base address for the device. If more than one base address is required, the second base address is set by registers 0x62 and 0x63. Refer to Table 25.7 on page 281 for the number of base address registers used by each device. Unused registers will ignore writes and return zero when read.

Table 25.6 Logical Device Registers (continued)

LOGICAL DEVICE REGISTER	ADDRESS	DESCRIPTION
Interrupt Select Defaults: 0x70 = 0x00 or 0x06 (Note 25.6) on VCC POR, VTR POR, PCI RESET and SOFT RESET 0x72 = 0x00, on VCC POR, VTR POR, PCI RESET and SOFT RESET	(0x70,0x72)	0x70 is implemented for each logical device. Refer to Interrupt Configuration Register description. Only the keyboard controller uses Interrupt Select register 0x72. Unused register (0x72) will ignore writes and return zero when read. Interrupts default to edge high (ISA compatible).
	(0x71,0x73)	Reserved - not implemented. These register locations ignore writes and return zero when read.
DMA Channel Select Default = 0x02 or 0x04 (Note 25.7) on VCC POR, VTR POR, PCI RESET and SOFT RESET	(0x74,0x75)	Only 0x74 is implemented for FDC and Parallel port. 0x75 is not implemented and ignores writes and returns zero when read. Refer to DMA Channel Configuration.
32-Bit Memory Space Configuration	(0x76-0xA8)	Reserved - not implemented. These register locations ignore writes and return zero when read.
Logical Device	(0xA9-0xDF)	Reserved - not implemented. These register locations ignore writes and return zero when read.
Logical Device Configuration	(0xE0-0xFE)	Reserved – Vendor Defined (see SMSC defined Logical Device Configuration Registers).
Reserved	0xFF	Reserved

Note 25.4 A logical device will be active and powered up according to the following equation unless otherwise specified:

DEVICE ON (ACTIVE) = (Activate Bit SET or Pwr/Control Bit SET).

The Logical device's Activate Bit and its Pwr/Control Bit are linked such that setting or clearing one sets or clears the other.

Note 25.5 If the I/O Base Addr of the logical device is not within the Base I/O range as shown in the Logical Device I/O map, then read or write is not valid and is ignored.

Note 25.6 The default value of the Primary Interrupt Select register for logical device 0 is 0x06.

Note 25.7 The default value of the DMA Channel Select register for logical device 0 (FDD) is 0x02 and for logical device 3 and 5 is 0x04.

Table 25.7 Base I/O Range for Logical Devices

LOGICAL DEVICE NUMBER	LOGICAL DEVICE	REGISTER INDEX	BASE I/O RANGE (NOTE E.10)	FIXED BASE OFFSETS
0x00	FDC	0x60,0x61	[0x0100:0x0FF8] ON 8 BYTE BOUNDARIES	+0 : SRA +1 : SRB +2 : DOR +3 : TDR +4 : MSR/DSR +5 : FIFO +7 : DIR/CCR
0x01	Reserved	n/a	n/a	n/a
0x02	Reserved	n/a	n/a	n/a
0x03	Parallel Port	0x60,0x61	[0x0100:0x0FFC] ON 4 BYTE BOUNDARIES (EPP Not supported) or [0x0100:0x0FF8] ON 8 BYTE BOUNDARIES	+0 : Data/ecpAfifo +1 : Status +2 : Control +400h : cfifo/ecpDfifo/tfifo/cnfgA +401h : cnfgB +402h : ecr
			(all modes supported, EPP is only available when the base address is on an 8-byte boundary)	+3 : EPP Address +4 : EPP Data 0 +5 : EPP Data 1 +6 : EPP Data 2 +7 : EPP Data 3
0x04	Serial Port 1	0x60,0x61	[0x0100:0x0FF8] ON 8 BYTE BOUNDARIES	+0 : RB/TB/LSB div +1 : IER/MSB div +2 : IIR/FCR +3 : LCR +4 : MSR +5 : LSR +6 : MSR +7 : SCR
0x05	Serial Port 2	0x60,0x61	[0x0100:0x0FF8] ON 8 BYTE BOUNDARIES	+0 : RB/TB/LSB div +1 : IER/MSB div +2 : IIR/FCR +3 : LCR +4 : MSR +5 : LSR +6 : MSR +7 : SCR
0x06	Reserved	n/a	n/a	n/a
0x07	KYBD	n/a	Not Relocatable Fixed Base Address: 60,64	+0 : Data Register +4 : Command/Status Reg.
0x08	Reserved	n/a	n/a	n/a
0x09	Reserved	n/a	n/a	n/a
0x0A	Runtime Register Block	0x60,0x61	[0x0000:0x0F7F] on 128-byte boundaries	+00 : PME Status . . . +5F : Keyboard Scan Code (See Table 26.2, "Runtime Register POR Summary," on page 297)

Table 25.7 Base I/O Range for Logical Devices (continued)

LOGICAL DEVICE NUMBER	LOGICAL DEVICE	REGISTER INDEX	BASE I/O RANGE (NOTE E.10)	FIXED BASE OFFSETS
	Security Key Register	0x62, 0x63	[0x0000:0x0FDF] on 32-byte boundaries	+00 : Security Key Byte 0 . . +1F: Security Key Byte 31
0x0B	Serial Port 3 SCH3114 AND SCH3116 DEVICES ONLY RESERVED IN SCH3112 DEVICE	0x60,0x61	[0x0100:0x0FF8] ON 8 BYTE BOUNDARIES	+0 : RB/TB/LSB div +1 : IER/MSB div +2 : IIR/FCR +3 : LCR +4 : MSR +5 : LSR +6 : MSR +7 : SCR
0x0C	Serial Port 4 SCH3114 AND SCH3116 DEVICES ONLY RESERVED IN SCH3112 DEVICE	0x60,0x61	[0x0100:0x0FF8] ON 8 BYTE BOUNDARIES	+0 : RB/TB/LSB div +1 : IER/MSB div +2 : IIR/FCR +3 : LCR +4 : MSR +5 : LSR +6 : MSR +7 : SCR
0x0D	Serial Port 5 SCH3116 DEVICE ONLY RESERVED IN SCH3112 AND SCH3114 DEVICES	0x60,0x61	[0x0100:0x0FF8] ON 8 BYTE BOUNDARIES	+0 : RB/TB/LSB div +1 : IER/MSB div +2 : IIR/FCR +3 : LCR +4 : MSR +5 : LSR +6 : MSR +7 : SCR
0x0E	Serial Port 6 SCH3116 DEVICE ONLY RESERVED IN SCH3112 AND SCH3114 DEVICES	0x60,0x61	[0x0100:0x0FF8] ON 8 BYTE BOUNDARIES	+0 : RB/TB/LSB div +1 : IER/MSB div +2 : IIR/FCR +3 : LCR +4 : MSR +5 : LSR +6 : MSR +7 : SCR
Config. Port	Config. Port	0x26, 0x27 (Note 25.9)	0x0100:0x0FFE On 2 byte boundaries	See description Configuration Register Summary and Description. Accessed through the index and DATA ports located at the Configuration Port address and the Configuration Port address +1 respectively.

Note 25.8 This chip uses address bits [A11:A0] to decode the base address of each of its logical devices. This device performs 16 bit address qualification, therefore address bits [A15:A12] must be '0'.

Note 25.9 The Configuration Port is at either 0x02E or 0x04E (for SYSOPT=0 or SYSOPT=1) at power up and can be relocated via CR12 and CR13.

Table 25.8 Primary Interrupt Select Register

NAME	REG INDEX	DEFINITION
Primary Interrupt Select Default=0x00 or 0x06 (Note 25.10) on VCC POR, VTR POR, PCI RESET and SOFT RESET	0x70 (R/W)	Bits[3:0] selects which interrupt is used for the primary Interrupt. 0x00= no interrupt selected 0x01= IRQ1 0x02= IRQ2/nSMI 0x03= IRQ3 0x04= IRQ4 0x05= IRQ5 0x06= IRQ6 0x07= IRQ7 0x08= IRQ8 0x09= IRQ9 0x0A= IRQ10 0x0B= IRQ11 0x0C= IRQ12 0x0D= IRQ13 0x0E= IRQ14 0x0F= IRQ15 Notes: 1. All interrupts are edge high (except ECP/EPP) 2. nSMI is active low

Notes: :

- An Interrupt is activated by setting the Interrupt Request Level Select 0 register to a non-zero value AND:
 - For the FDC logical device by setting DMAEN, bit D3 of the Digital Output Register.
 - For the PP logical device by setting IRQE, bit D4 of the Control Port and in addition
 - For the PP logical device in ECP mode by clearing serviceIntr, bit D2 of the ecr.
 - For the Serial Port logical device by setting any combination of bits D0-D3 in the IER and by setting the OUT2 bit in the UART's Modem Control (MCR) Register.
 - For the KYBD logical device (refer to [Chapter 12, "8042 Keyboard Controller Description," on page 129](#)).
- IRQs are disabled if not used/selected by any Logical Device. Refer to [Note 25.11 on page 284](#).
- nSMI must be disabled to use IRQ2.
- All IRQ's are available in Serial IRQ mode.

Note 25.10 The default value of the Primary Interrupt Select register for logical device 0 is 0x06.

Table 25.9 DMA Channel Select

NAME	REG INDEX	DEFINITION
DMA Channel Select Default=0x02 or 0x04 (See notes) on VCC POR, VTR POR, PCI RESET and SOFT RESET	0x74 (R/W)	Bits[2:0] select the DMA Channel. 0x00= Reserved 0x01= DMA1 0x02= DMA2 0x03= DMA3 0x04-0x07= No DMA active

Notes:

- A DMA channel is activated by setting the DMA Channel Select register to [0x01-0x03] AND:
 - For the FDC logical device by setting DMAEN, bit D3 of the Digital Output Register.

- For the PP logical device in ECP mode by setting dmaEn, bit D3 of the ecr.
- The DMA channel must be disabled if not used/selected by any Logical Device. Refer to Note A.
- The default value of the DMA Channel Select register for logical device 0 (FDD) is 0x02 and for logical device 3 and 5 is 0x04. The FDC must always be assigned to DMA Channel 2.

Note 25.11 Logical Device IRQ and DMA Operation. IRQ and DMA Enable and Disable: Any time the IRQ or DMA channel for a logical block is disabled by a register bit in that logical block, the IRQ and/or DMA channel must be disabled. This is in addition to the IRQ and DMA channel disabled by the Configuration Registers (Active bit or address not valid).

FDC: For the following cases, the IRQ and DMA channel used by the FDC are disabled.

Digital Output Register (Base+2) bit D3 (DMAEN) set to "0".

The FDC is in power down (disabled).

Serial Ports:

Modem Control Register (MCR) Bit D2 (OUT2) - When OUT2 is a logic "0", the serial port interrupt is disabled.

Disabling DMA Enable bit, disables DMA for UART2. Refer to the IrCC specification.

Parallel Port:

SPP and EPP modes: Control Port (Base+2) bit D4 (IRQE) set to "0", IRQ is disabled.

ECP Mode:

- (DMA) dmaEn from ecr register. See table.
- IRQ - See table.

MODE (FROM ECR REGISTER)		IRQ CONTROLLED BY	DMA CONTROLLED BY
000	PRINTER	IRQE	dmaEn
001	SPP	IRQE	dmaEn
010	FIFO	(on)	dmaEn
011	ECP	(on)	dmaEn
100	EPP	IRQE	dmaEn
101	RES	IRQE	dmaEn
110	TEST	(on)	dmaEn
111	CONFIG	IRQE	dmaEn

Keyboard Controller: Refer to the [8042 Keyboard Controller Description on page 129](#) of this spec

SMSC Defined Logical Device Configuration Registers

The SMSC Specific Logical Device Configuration Registers reset to their default values only on PCI resets generated by Vcc or VTR POR (as shown) or the PCI_RESET# signal. These registers are not affected by soft resets.

Table 25.10 Floppy Disk Controller, Logical Device 0 [Logical Device Number = 0X00

NAME	REG INDEX	DEFINITION
FDD Mode Register Default = 0x0E on VCC POR, VTR POR and PCI RESET	0xF0 R/W	Bit[0] Floppy Mode = 0 Normal Floppy Mode (default) = 1 Enhanced Floppy Mode 2 (OS2) Bit[1] FDC DMA Mode = 0 Burst Mode is enabled = 1 Non-Burst Mode (default) Bit[3:2] Interface Mode = 11 AT Mode (default) = 10 (Reserved) = 01 PS/2 = 00 Model 30 Bit[4] Reserved (read/write bit) Bit[5] Reserved, set to zero Bit[6] FDC Output Type Control = 0 FDC outputs are OD12 open drain (default) = 1 FDC outputs are O12 push-pull Bit[7] FDC Output Control = 0 FDC outputs active (default) = 1 FDC outputs tri-stated
FDD Option Register Default = 0x00 on VCC POR, VTR POR and PCI RESET	0xF1 R/W	Bit[0] Forced Write Protect = 0 Inactive (default) = 1 FDD nWRTPRT input is forced active when either of the drives has been selected. nWRTPRT (to the FDC Core) = WP (FDC SRA register, bit 1) = (nDS0 AND Forced Write Protect) OR (nDS1 AND Forced Write Protect) OR nWRTPRT (from the FDD Interface) OR Floppy Write Protect Notes: <ul style="list-style-type: none"> ■ The Floppy Write Protect bit is in the Device Disable register. ■ Boot floppy is always drive 0. Bit[1] Reserved Bits[3:2] Density Select = 00 Normal (default) = 01 Normal (reserved for users) = 10 1 (forced to logic "1") = 11 0 (forced to logic "0") Bit[7:4] Reserved. (read/write bits)
FDD Type Register Default = 0xFF on VCC POR, VTR POR and PCI RESET	0xF2 R/W	Bits[1:0] Floppy Drive A Type Bits[3:2] Floppy Drive B Type Bits[5:4] Reserved (could be used to store Floppy Drive C type) Bits[7:6] Reserved (could be used to store Floppy Drive D type) Note: The SCH311X supports two floppy drives
	0xF3 R	Reserved, Read as 0 (read only)
FDD0 Default = 0x00 on VCC POR, VTR POR and PCI RESET	0xF4 R/W	Bits[1:0] Drive Type Select: DT1, DT0 Bits[2] Read as 0 (read only) Bits[4:3] Data Rate Table Select: DRT1, DRT0 Bits[5] Read as 0 (read only) Bits[6] Precompensation Disable PTS =0 Use Precompensation =1 No Precompensation Bits[7] Read as 0 (read only)
FDD1	0xF5 R/W	Refer to definition and default for 0xF4

Table 25.11 Parallel Port, Logical Device 3 [Logical Device Number = 0x03]

NAME	REG INDEX	DEFINITION
PP Mode Register Default = 0x3C on VCC POR, VTR POR and PCI RESET	0xF0 R/W	Bits[2:0] Parallel Port Mode = 100 Printer Mode (default) = 000 Standard and Bi-directional (SPP) Mode = 001 EPP-1.9 and SPP Mode = 101 EPP-1.7 and SPP Mode = 010 ECP Mode = 011 ECP and EPP-1.9 Mode = 111 ECP and EPP-1.7 Mode Bit[6:3] ECP FIFO Threshold 0111b (default) Bit[7] PP Interrupt Type Not valid when the parallel port is in the Printer Mode (100) or the Standard & Bi-directional Mode (000). = 1 Pulsed Low, released to high-Z. = 0 IRQ follows nACK when parallel port in EPP Mode or [Printer, SPP, EPP] under ECP. IRQ level type when the parallel port is in ECP, TEST, or Centronics FIFO Mode.
PP Mode Register 2 Default = 0x00 on VCC POR, VTR POR and PCI RESET	0xF1 R/W	Bit [3:0] Reserved. Set to zero. Bit [4] TIMEOUT_SELECT = 0 TMOU (EPP Status Reg.) cleared on write of '1' to TMOU. = 1 TMOU cleared on trailing edge of read of EPP Status Reg. Bits[7:5] Reserved. Set to zero.

Table 25.12 Serial Port 1, Logical Device 4 [Logical Device Number = 0X04]

NAME	REG INDEX	DEFINITION
Serial Port 1 Mode Register Default = 0x00 on VCC POR, VTR POR and PCI RESET	0xF0 R/W	Bit[0] MIDI Mode = 0 MIDI support disabled (default) = 1 MIDI support enabled Bit[1] High Speed = 0 High Speed Disabled(default) = 1 High Speed Enabled Bit [3:2] Enhanced Frequency Select = 00 Standard Mode (default) = 01 Select 921K = 10 Select 1.5M = 11 Reserved Bit[5:4] Reserved, set to zero Bit[6] All Share IRQ =0 Use bit 7 to determine sharing =1 Share all serial ports on the SCH311X device. SCH3112 - share 2 serial ports SCH3114 - share 4 serial ports SCH3116 - share 6 serial ports Bit[7]: Share IRQ =0 UARTS 1,2 use different IRQs =1 UARTS 1,2 share a common IRQ (Note 25.12)

Datasheet

Note 25.12 To properly share and IRQ:

1. Configure UART1 (or UART2) to use the desired IRQ.
2. Configure UART2 (or UART1) to use No IRQ selected.
3. Set the share IRQ bit.

Note: If both UARTs are configured to use different IRQs and the share IRQ bit is set, then both of the UART IRQs will assert when either UART generates an interrupt.

Table 25.13 Serial Port 2. Logical Device 5 [Logical Device Number = 0X05]

NAME	REG INDEX	DEFINITION
Serial Port 2 Mode Register Default = 0x00 on VCC POR, VTR POR and PCI RESET	0xF0 R/W	Bit[0] MIDI Mode = 0 MIDI support disabled (default) = 1 MIDI support enabled Bit[1] High Speed = 0 High Speed Disabled(default) = 1 High Speed Enabled Bit [3:2] Enhanced Frequency Select = 00 Standard Mode (default) = 01 Select 921K = 10 Select 1.5M = 11 Reserved Bit[4] Reserved, set to zero Bit[5] TXD2_MODE (See Note 25.13 .) =0 TXD2 pin reflects current configuration state =1 Override current pin configuration and force TXD2 pin tristate. Bits[7:6] Reserved. Set to zero.
IR Option Register Default = 0x02 on VCC POR, VTR POR and PCI RESET	0xF1 R/W	Bit[0] Receive Polarity = 0 Active High (Default) = 1 Active Low Bit[1] Transmit Polarity = 0 Active High = 1 Active Low (Default) Bit[2] Duplex Select = 0 Full Duplex (Default) = 1 Half Duplex Bits[5:3] IR Mode = 000 Standard COM Functionality (Default) = 001 IrDA = 010 ASK-IR = 011 Reserved = 1xx Reserved Bit[6] Reserved Set to 0. Bit[7] Reserved, write 0.
IR Half Duplex Timeout Default = 0x03 on VCC POR, VTR POR and PCI RESET	0xF2	Bits [7:0] These bits set the half duplex time-out for the IR port. This value is 0 to 10msec in 100usec increments. 0= blank during transmit/receive 1= blank during transmit/receive + 100usec

Note 25.13 The TXD2_MODE bit is a VTR powered bit that is reset on VTR POR only.

Table 25.14 KYBD. Logical Device 7 [Logical Device Number = 0X07]

NAME	REG INDEX	DEFINITION
KRST_GA20 Default = 0x00 on VCC POR, VTR POR and PCI RESET Bits[6:5] reset on VTR POR only	0xF0 R/W	KRESET and GateA20 Select Bit[7] Polarity Select for P12 = 0 P12 active low (default) = 1 P12 active high Bit[6] M_ISO. Enables/disables isolation of mouse signals into 8042. Does not affect MDAT signal to mouse wakeup (PME) logic. 1= block mouse clock and data signals into 8042 0= do not block mouse clock and data signals into 8042 Bit[5] K_ISO. Enables/disables isolation of keyboard signals into 8042. Does not affect KDAT signal to keyboard wakeup (PME) logic. 1= block keyboard clock and data signals into 8042 0= do not block keyboard clock and data signals into 8042 Bit[4] MLATCH = 0 MINT is the 8042 MINT ANDed with Latched MINT (default) = 1 MINT is the latched 8042 MINT Bit[3] KLATCH = 0 KINT is the 8042 KINT ANDed with Latched KINT (default) = 1 KINT is the latched 8042 KINT Bit[2] Port 92 Select = 0 Port 92 Disabled = 1 Port 92 Enabled Bit[1] Reserved (read/write bit) Bit[0] Reserved (read/write bit)

Table 25.15 Logical Device A [Logical Device Number = 0X0A]

NAME	REG INDEX	DEFINITION
CLOCKI32 Default = 0x00 on VTR POR	0xF0 (R/W)	Bit[0] (CLK32_PRSN) 0 = 32kHz clock is connected to the CLKI32 pin (default) 1 = 32kHz clock is not connected to the CLKI32 pin (pin is grounded) Bit[1] SPEKEY_EN. This bit is used to turn the logic for the “wake on specific key” feature on and off. It will disable the 32kHz clock input to the logic when turned off. The logic will draw no power when disabled. 0 = “Wake on specific key” logic is on (default) 1 = “Wake on specific key” logic is off Bit[2] Reserved (read-only bit) Reads return 0. Writes have no effect. Bit[3] SPEMSE_EN This bit is used to turn the logic for the “wake on specific mouse click” feature on and off. It will disable the 32 Khz clock input to the logic when turned off. The logic will draw no power when disabled. 0 = “wake on specific mouse click” logic is on (default) 1 = “wake on specific mouse click” logic is off Bits[7:4] are reserved
FDC on PP Mode Register Default = 0x00 on VCC POR, VTR POR and PCI RESET	0xF1 R/W	FDC on PP Mode Register Bit [1:0] Parallel Port FDC 00=Normal PP and FDC mode 01 =Mode 1 - Drive 0 on FDC, Drive 1 on PP 10 = Mode 2 - Drive 0/1 on PP 11 = Reserved Bits[7:3] Reserved. Set to zero.

Datasheet

Table 25.15 Logical Device A [Logical Device Number = 0X0A] (continued)

NAME	REG INDEX	DEFINITION
Security Key Control (SKC) Register Default=0x04 on a VTR POR, VCC POR, PCI Reset	0xF2 R/W when bit[0]= 0 Read-Only when bit[0]=1	Bit[0] SKC Register Lock This bit blocks write access to the Security Key Control Register. 0 = Security Key Control Register is a Read/Write register (default) 1 = Security Key Control Register is a Read-Only register Bit[1] Read-Lock This bit prevents reads from the Security Key registers located at an offset from the Secondary Base I/O address in Logical Device A 0 = Permits read operations in the Security Key block (default) 1 = Prevents read operations in the Security Key block (Reads return 00h.) Bit[2] Write-Lock This bit prevents writes to the Security Key registers located at an offset from the Secondary Base I/O address in Logical Device A 0 = Permits write operations in the Security Key block 1 = Prevents write operations in the Security Key block (default) Bit[3] Reserved Bit[4] Reserved Bit[5] Reserved Bit[6] Reserved Bit[7] Reserved

Note: The registers located in Logical Device A are runtime registers.

Table 25.16 Serial Port 3, Logical Device B [Logical Device Number = 0X0B]

NAME	REG INDEX	DEFINITION
Serial Port 3 Mode Register Default = 0x00 on VCC POR, VTR POR and PCI RESET SCH3112 device.	0xF0 R/W	Bit[7:0] SMSC Test Bit Must be written with zero for proper operation.
Serial Port 3 Mode Register Default = 0x00 on VCC POR, VTR POR and PCI RESET SCH3114 and the SCH3116 device.	0xF0 R/W	SCH 3114, SCH3116 devices Bit[0] MIDI Mode = 0 MIDI support disabled (default) = 1 MIDI support enabled Bit[1] High Speed = 0 High Speed Disabled(default) = 1 High Speed Enabled Bit [3:2] Enhanced Frequency Select = 00 Standard Mode (default) = 01 Select 921K = 10 Select 1.5M = 11 Reserved Bit[5:4] Reserved, set to zero Bit[6] SMSC Test Bit Must be written with zero for proper operation. Bit[7]: Share IRQ =0 UARTS 3,4 use different IRQs =1 UARTS 3,4 share a common IRQ (Note 25.12)

Table 25.17 Serial Port 4, Logical Device C Logical Device Number = 0X0C

NAME	REG INDEX	DEFINITION
Serial Port 4 Mode Register Default = 0x00 on VCC POR, VTR POR and PCI RESET SCH3112 device.	0xF0 R/W	SCH3112 Device Bit[7:0] SMSC Test Bit Must be written with zero for proper operation.
Serial Port 4 Mode Register Default = 0x00 on VCC POR, VTR POR and PCI RESET Note: This register will only be used for the SCH3114 and the SCH3116 device.	0xF0 R/W	SCH 3114, SCH3116 devices Bit[0] MIDI Mode = 0 MIDI support disabled (default) = 1 MIDI support enabled Bit[1] High Speed = 0 High Speed Disabled(default) = 1 High Speed Enabled Bit [3:2] Enhanced Frequency Select = 00 Standard Mode (default) = 01 Select 921K = 10 Select 1.5M = 11 Reserved Bit[5:4] Reserved, set to zero Bit[7:6] SMSC Test Bit Must be written with zero for proper operation.

Table 25.18 Serial Port 5, Logical Device D [Logical Device Number = 0X0D]

NAME	REG INDEX	DEFINITION
Serial Port 5 Mode Register Default = 0x00 on VCC POR, VTR POR and PCI RESET SCH3112 and SCH3114 devices.	0xF0 R/W	SCH3112, SCH3114 Devices Bit[7:0] SMSC Test Bit Must be written with zero for proper operation.

Datasheet

Table 25.18 Serial Port 5, Logical Device D [Logical Device Number = 0X0D] (continued)

NAME	REG INDEX	DEFINITION
Serial Port 5 Mode Register Default = 0x00 on VCC POR, VTR POR and PCI RESET SCH3116 device	0xF0 R/W	SCH3116 devices Bit[0] MIDI Mode = 0 MIDI support disabled (default) = 1 MIDI support enabled Bit[1] High Speed = 0 High Speed Disabled(default) = 1 High Speed Enabled Bit [3:2] Enhanced Frequency Select = 00 Standard Mode (default) = 01 Select 921K = 10 Select 1.5M = 11 Reserved Bit[5:4] Reserved, set to zero Bit[6] SMSC Test Bit Must be written with zero for proper operation. Bit[7]: Share IRQ =0 UARTS 5,6 use different IRQs =1 UARTS 5,6 share a common IRQ (Note 25.12)

Table 25.19 Serial Port 6, Logical Device E Logical Device Number = 0X0E

NAME	REG INDEX	DEFINITION
Serial Port 6 Mode Register Default = 0x00 on VCC POR, VTR POR and PCI RESET SCH3112 and SCH3114 devices	0xF0 R/W	SCH3112, SCH3114 Devices Bit[7:0] SMSC Test Bit Must be written with zero for proper operation.n.
Serial Port 6 Mode Register Default = 0x00 on VCC POR, VTR POR and PCI RESET SCH3116 device	0xF0 R/W	SCH3116 devices Bit[0] MIDI Mode = 0 MIDI support disabled (default) = 1 MIDI support enabled Bit[1] High Speed = 0 High Speed Disabled(default) = 1 High Speed Enabled Bit [3:2] Enhanced Frequency Select = 00 Standard Mode (default) = 01 Select 921K = 10 Select 1.5M = 11 Reserved Bit[5:4] Reserved, set to zero Bit[7:6] SMSC Test Bit Must be written with zero for proper operation.



Chapter 26 Runtime Register

26.1 Runtime Register

The following registers are runtime registers in the SCH311X. They are located at the address programmed in the Base I/O Address in Logical Device A (also referred to as the Runtime Register) at the offset shown. These registers are powered by VTR.

[Table 26.1](#) summarizes the runtime register differences between the 311X family of devices. [Table 26.2](#) gives the POR information for each of the registers. A complete description of each of the registers is given in [Section 26.2, "Runtime Register Description,"](#) on page 303.

Table 26.1 SCH311X Runtime Register Summary

REGISTER OFFSET (HEX)	SCH3112 REGISTER	SCH3114 REGISTER	SCH3116 REGISTER
00	PME_STS	PME_STS	PME_STS
01	Reserved – reads return 0	Reserved – reads return 0	Reserved – reads return 0
02	PME_EN	PME_EN	PME_EN
03	Reserved – reads return 0	Reserved – reads return 0	Reserved – reads return 0
04	PME_STS1	PME_STS1	PME_STS1
05	PME_STS3	PME_STS3	PME_STS3
06	PME_STS5 (Note 26.1)	PME_STS5 (Note 26.1)	PME_STS5 (Note 26.1)
07	PME_STS6	PME_STS6	PME_STS6 (Note 26.2)
08	PME_EN1	PME_EN1	PME_EN1
09	PME_EN3	PME_EN3	PME_EN3
0A	PME_EN5	PME_EN5	PME_EN5
0B	PME_EN6	PME_EN6	PME_EN6 (Note 26.2)
0C	PME_STS7 (Note 26.3)	PME_STS7 (Note 26.3)	PME_STS7 (Note 26.3)
0D	Reserved – reads return 0	Reserved – reads return 0	Reserved – reads return 0
0E	Reserved – reads return 0	Reserved – reads return 0	Reserved – reads return 0
0F	Reserved – reads return 0	Reserved – reads return 0	Reserved – reads return 0
10	PME_EN7 (Note 26.3)	PME_EN7 (Note 26.3)	PME_EN7 (Note 26.3)
11	Reserved – reads return 0	Reserved – reads return 0	Reserved – reads return 0
12	SP12	SP12	SP12
13	Reserved – reads return 0	SP34	SP34
14	SMI_STS1	SMI_STS1	SMI_STS1
15	SMI_STS2	SMI_STS2	SMI_STS2
16	SMI_STS3	SMI_STS3	SMI_STS3

Table 26.1 SCH311X Runtime Register Summary (continued)

REGISTER OFFSET (HEX)	SCH3112 REGISTER	SCH3114 REGISTER	SCH3116 REGISTER
17	SMI_STS4 (Note 26.4)	SMI_STS4 (Note 26.4)	SMI_STS4 (Note 26.4)
18	SMI_EN1	SMI_EN1	SMI_EN1
19	SMI_EN2	SMI_EN2	SMI_EN2
1A	SMI_EN3	SMI_EN3	SMI_EN3
1B	SMI_EN4 (Note 26.4)	SMI_EN4 (Note 26.4)	SMI_EN4 (Note 26.4)
1C	MSC_STS	MSC_STS	MSC_STS
1D	RESGEN	RESGEN	RESGEN
1E	Force Disk Change	Force Disk Change	Force Disk Change
1F	Floppy Data Rate Select Shadow	Floppy Data Rate Select Shadow	Floppy Data Rate Select Shadow
20	UART1 FIFO Control Shadow	UART1 FIFO Control Shadow	UART1 FIFO Control Shadow
21	UART2 FIFO Control Shadow	UART2 FIFO Control Shadow	UART2 FIFO Control Shadow
22	Reserved - read returns 0	UART3 FIFO Control Shadow	UART3 FIFO Control Shadow
23	GP10	GP10 (Note 26.6)	GP10 (Note 26.6)
24	GP11	GP11 (Note 26.6)	GP11 (Note 26.6)
25	GP12	GP12 (Note 26.6)	GP12 (Note 26.6)
26	GP13	GP13 (Note 26.6)	GP13 (Note 26.6)
27	GP14	GP14 (Note 26.6)	GP14 (Note 26.6)
28	RESERVED - reads return 0	UART4 FIFO Control Shadow	UART4 FIFO Control Shadow
29	GP15	GP15 (Note 26.6)	GP15 (Note 26.6)
2A	GP16	GP16 (Note 26.6)	GP16 (Note 26.6)
2B	GP17	GP17 (Note 26.6)	GP17 (Note 26.6)
2C	GP21	GP21	GP21
2D	GP22	GP22	GP22
2E	RESERVED - reads return 0	RESERVED - reads return 0	UART5 FIFO Control Shadow
2F	RESERVED - reads return 0	RESERVED - reads return 0	UART6 FIFO Control Shadow
30	RESERVED - reads return 0	RESERVED - reads return 0	SP5 Option
31	RESERVED - reads return 0	RESERVED - reads return 0	SP6 Option
32	GP27	GP27	GP27
33	GP30	GP30	GP30
34	GP31	GP31(Note 26.6)	GP31(Note 26.6)
35	GP32	GP32	GP32

Table 26.1 SCH311X Runtime Register Summary (continued)

REGISTER OFFSET (HEX)	SCH3112 REGISTER	SCH3114 REGISTER	SCH3116 REGISTER
36	GP33	GP33	GP33
37	GP34	GP34 (Note 26.6)	GP34 (Note 26.6)
38	Reserved	Reserved	Reserved
39	GP36	GP36	GP36
3A	GP37	GP37	GP37
3B	GP40	GP40	GP40
3C	CLK_OUT Register	CLK_OUT Register	CLK_OUT Register
3D	GP42	GP42	GP42
3E	Reserved – reads return 0	Reserved – reads return 0	Reserved – reads return 0
3F	GP50	GP50	GP50
40	GP51	GP51	GP51
41	GP52	GP52	GP52
42	GP53	GP53	GP53
43	GP54	GP54	GP54
44	GP55	GP55	GP55
45	GP56	GP56	GP56
46	GP57	GP57	GP57
47	GP60	GP60	GP60
48	GP61	GP61	GP61
49	PWR_REC	PWR_REC	Reserved – reads return 0 (Note 26.2)
4A	PS_ON Register	PS_ON Register	Reserved – reads return 0 (Note 26.2)
4B	GP1	GP1	GP1
4C	GP2	GP2	GP2
4D	GP3	GP3	GP3
4E	GP4	GP4	GP4
4F	GP5	GP5	GP5
50	GP6	GP6	GP6
51	Reserved – reads return 0	Reserved – reads return 0	Reserved – reads return 0
52	Reserved – reads return 0	Reserved – reads return 0	Reserved – reads return 0
53	PS_ON# Previous State	PS_ON# Previous State	Reserved – reads return 0 (Note 26.2)

Table 26.1 SCH311X Runtime Register Summary (continued)

REGISTER OFFSET (HEX)	SCH3112 REGISTER	SCH3114 REGISTER	SCH3116 REGISTER
54	GP62	GP62 (Note 26.6)	GP62 (Note 26.6)
55	GP63	GP63 (Note 26.6)	GP63 (Note 26.6)
56	GP64	GP64(Note 26.6)	GP64(Note 26.6)
57	GP65	GP65(Note 26.6)	GP65(Note 26.6)
58	GP66	GP66(Note 26.6)	GP66(Note 26.6)
59	GP67	GP67 (Note 26.6)	GP67 (Note 26.6)
5A	TEST	TEST	TEST
5B	DBLCLICK	DBLCLICK	DBLCLICK
5C	Mouse_Specific_Wake	Mouse_Specific_Wake	Mouse_Specific_Wake
5D	LED1	LED1	LED1
5E	LED2	LED2	LED2
5F	Keyboard Scan Code – Make Byte 1	Keyboard Scan Code – Make Byte 1	Keyboard Scan Code – Make Byte 1
60	Keyboard Scan Code – Make Byte 2	Keyboard Scan Code – Make Byte 2	Keyboard Scan Code – Make Byte 2
61	Keyboard Scan Code – Break Byte 1	Keyboard Scan Code – Break Byte 1	Keyboard Scan Code – Break Byte 1
62	Keyboard Scan Code – Break Byte 2	Keyboard Scan Code – Break Byte 2	Keyboard Scan Code – Break Byte 2
63	Keyboard Scan Code – Break Byte 3	Keyboard Scan Code – Break Byte 3	Keyboard Scan Code – Break Byte 3
64	Keyboard PWRBTN/SPEKEY	Keyboard PWRBTN/SPEKEY	Keyboard PWRBTN/SPEKEY
65	WDT_TIME_OUT	WDT_TIME_OUT	WDT_TIME_OUT
66	WDT_VAL	WDT_VAL	WDT_VAL
67	WDT_CFG	WDT_CFG	WDT_CFG
68	WDT_CTRL	WDT_CTRL	WDT_CTRL
69	Reserved – reads return 0	Reserved – reads return 0	Reserved – reads return 0
6A	Reserved – reads return 0	Reserved – reads return 0	Reserved – reads return 0
6B	Reserved – reads return 0	Reserved – reads return 0	Reserved – reads return 0

Datasheet

Table 26.1 SCH311X Runtime Register Summary (continued)

REGISTER OFFSET (HEX)	SCH3112 REGISTER	SCH3114 REGISTER	SCH3116 REGISTER
6C	Reserved – reads return 0	Reserved – reads return 0	Reserved – reads return 0
6D	TEST	TEST	TEST
6E	GP44 (Note 26.7)	GP44 (Note 26.7)	GP44 (Note 26.8)
6F	GP45 (Note 26.7)	GP45 (Note 26.7)	GP45 (Note 26.8)
70	HWM Index Register	HWM Index Register	HWM Index Register
71	HWM Data Register	HWM Data Register	HWM Data Register
72	GP46 (Note 26.7)	GP46 (Note 26.7)	GP46 (Note 26.8)
73	GP47 (Note 26.7)	GP47 (Note 26.7)	GP47 (Note 26.8)
74-7Fh	Reserved – reads return 0	Reserved – reads return 0	Reserved – reads return 0

Table 26.2 Runtime Register POR Summary

REGISTER OFFSET (HEX)	TYPE	PCI RESET	VCC POR	VTR POR	SOFT RESET	VBAT POR	REGISTER
00	R/WC	-	-	0x00	-	-	PME_STS
01	R	-	-	-	-	-	Reserved – reads return 0
02	R/W	-	-	0x00	-	-	PME_EN
03	R	-	-	-	-	-	Reserved – reads return 0
04	R/WC	-	-	0x00	-	-	PME_STS1
05	R/WC	-	-	0x00	-	-	PME_STS3
06	R/WC	-	-	0x00	-	-	PME_STS5 (Note 26.1)
07	R/WC	-	-	Note 26.9	-	-	PME_STS6
08	R/W	-	-	0x00)	-	-	PME_EN1
09	R/W	-	-	0x00	-	-	PME_EN3
0A	R/W	-	-	0x00	-	-	PME_EN5
0B	R/W	-	-	0x00	-	-	PME_EN6
0C	R	-	-	0x00	-	-	RESERVED (SCH3112)
0C	R/WC	-	-	0x00	-	-	PME_STS7 (SCH3114 and SCH3116)
0D	R	-	-	-	-	-	Reserved – reads return 0
0E	R	-	-	-	-	-	Reserved – reads return 0
0F	R	-	-	-	-	-	Reserved – reads return 0

Table 26.2 Runtime Register POR Summary (continued)

REGISTER OFFSET (HEX)	TYPE	PCI RESET	VCC POR	VTR POR	SOFT RESET	VBAT POR	REGISTER
10	R	-	-	0x00	-		RESERVED (SCH3112)
10	R/W	-	-	0x00	-		PME_EN7 (SCH3114 and SCH3116)
11	R	-	-	0x00	-		RESERVED
12	R/W	-	-	0x44	-		SP12
13	R	-	-	0x00	-		RESERVED (SCH3112)
13	R/W	-	-	0x00	-		SP34 (SCH3114 and SCH3116)
14	Note 26.16	-	-	Note 26.9	-	-	SMI_STS1
15	Note 26.16	-	-	0x00	-	-	SMI_STS2
16	R/WC	-	-	0x00	-	-	SMI_STS3
17	R/WC	-	-	0x00	-	-	SMI_STS4
18	R/W	-	-	0x00	-	-	SMI_EN1
19	R/W	-	-	0x00	-	-	SMI_EN2
1A	R/W	-	-	0x00	-	-	SMI_EN3
1B	R/W	-	-	0x00	-	-	SMI_EN4
1C	R/W	-	-	0x00	-	-	MSC_STS
1D	R/W	-	-	0x00	-	-	REGEN
1E	R/W	0x03	0x03	0x03	-	-	Force Disk Change
1F	R	-	-	-	-	-	Floppy Data Rate Select Shadow
20	R	-	-	-	-	-	UART1 FIFO Control Shadow
21	R	-	-	-	-	-	UART2 FIFO Control Shadow
22	R	-	-	-	-	-	RESERVED
22	R	-	-	-	-	-	UART3 FIFO Control Shadow (SCH3114 and SCH3116)
23	R/W	-	-	0x01	-	-	GP10
24	R/W	-	-	0x01	-	-	GP11
25	R/W	-	-	0x01	-	-	GP12
26	R/W	-	-	0x01	-	-	GP13

Datasheet

Table 26.2 Runtime Register POR Summary (continued)

REGISTER OFFSET (HEX)	TYPE	PCI RESET	VCC POR	VTR POR	SOFT RESET	VBAT POR	REGISTER
27	R/W	-	-	0x01	-	-	GP14
28	R	-	-	0x00	-	-	RESERVED (SCH3112)
28	R	-	-	0x00	-	-	UART4 FIFO Control Shadow (SCH3114 and SCH3116)
29	R	-	-	0x01	-	-	GP15
2A	R	-	-	0x01	-	-	GP16
2B	R	-	-	0x01	-	-	GP17
2C	R/W	-	-	0x8C	-	-	GP21
2D	R/W	-	-	0x8C	-	-	GP22
2E	R	-	-	0x00	-	-	RESERVED (SCH3112 and SCH3114)
2E	R	-	-	0x00	-	-	UART5 FIFO Control Shadow (SCH3116)
2F	R	-	-	0x00	-	-	RESERVED (SCH3112 and SCH3114)
2F	R	-	-	0x00	-	-	UART6 FIFO Control Shadow (SCH3116)
30	R	-	-	0x00	-	-	RESERVED (SCH3112 and SCH3114)
30	R/W	-	-	0x04	-	-	SP5 Option (SCH3116)
31	R	-	-	0x00	-	-	RESERVED (SCH3112 and SCH3114)
31	R/W	-	-	0x04	-	-	SP6 Option (SCH3116)
32	R/W	-	-	0x01	-	-	GP27
33	R/W	-	-	0x05	-	-	GP30
34	R/W	-	-	0x01	-	-	GP31
35	R/W	-	-	0x84	-	-	GP32
36	R/W	-	-	0x84	-	-	GP33
37	R/W	-	-	0x01	-	-	GP34
38	R	-	-	-	-	-	Reserved
39	R/W	-	-	0x01	-	-	GP36
3A	R/W	-	-	0x01	-	-	GP37

Table 26.2 Runtime Register POR Summary (continued)

REGISTER OFFSET (HEX)	TYPE	PCI RESET	VCC POR	VTR POR	SOFT RESET	VBAT POR	REGISTER
3B	R/W	-	-	0x01	-	-	GP40
3C	R	-	-	0x00	-	-	CLK_OUT Register
3D	R/W	-	-	0x01	-	-	GP42
3E	R	-	-	-	-	-	Reserved – reads return 0
3F	R/W	-	-	0x01	-	-	GP50
40	R/W	-	-	0x01	-	-	GP51
41	R/W	-	-	0x01	-	-	GP52
42	R/W	-	-	0x01	-	-	GP53
43	R/W	-	-	0x01	-	-	GP54
44	R/W	-	-	0x01	-	-	GP55
45	R/W	-	-	0x01	-	-	GP56
46	R/W	-	-	0x01	-	-	GP57
47	R/W	-	-	0x01	-	-	GP60
48	R/W	-	-	0x01	-	-	GP61
49	Note 26.11	0xxxxxxx xb Note 26.12	-	0xxxxxxx 11b Note 26.12	-	0x00000 xxb Note 26.12	PWR_REC (SCH3112 and SCH3114)
49	R	0xxxxxxx xb Note 26.12	-	0xxxxxxx 11b Note 26.12	-	0x00000 xxb Note 26.12	RESERVED (SCH3116)
4A	R	-	-	-	-	0x00	PS_ON Register (SCH3112 and SCH3114)
4A	R	-	-	-	-	0x00	RESERVED (SCH3116)
4B	R/W	-	-	0x00	-	-	GP1
4C	R/W	-	-	0x00	-	-	GP2
4D	R/W	-	-	0x00	-	-	GP3
4E	R/W	-	-	0x00	-	-	GP4
4F	R/W	-	-	0x00	-	-	GP5
50	R/W	-	-	0x00	-	-	GP6
51	R	-	-	-	-	-	Reserved – reads return 0
52	R	-	-	-	-	-	Reserved – reads return 0
53	R/W	-	-	-	-	0x00	PS_ON# Previous State (SCH3112 and SCH3114)

Datasheet

Table 26.2 Runtime Register POR Summary (continued)

REGISTER OFFSET (HEX)	TYPE	PCI RESET	VCC POR	VTR POR	SOFT RESET	VBAT POR	REGISTER
53	R	-	-	-	-	0x00	RESERVED (SCH3116)
54	R	-	-	0x01	-	-	GP62
55	R	-	-	0x01	-	-	GP63
56	R	-	-	0x01	-	-	GP64
57	R	-	-	0x01	-	-	GP65
58	R	-	-	0x01	-	-	GP66
59	R	-	-	0x01	-	-	GP67
5A	R	-	-	-	-	-	TEST
5B	Note 26.17	-	-	-	-	0x0C	DBLCLICK
5C	Note 26.17	Note 26.9	Note 26.9	Note 26.9	-	-	Mouse_Specific_Wake
5D	R/W	-	-	0x00	-	-	LED1
5E	R/W	-	-	0x00	-	-	LED2
5F	Note 26.13	-	-	-	-	0xE0	Keyboard Scan Code – Make Byte 1
60	Note 26.13	-	-	-	-	0x37	Keyboard Scan Code – Make Byte 2
61	Note 26.13	-	-	-	-	0xE0	Keyboard Scan Code – Break Byte 1
62	Note 26.13	-	-	-	-	0xF0	Keyboard Scan Code – Break Byte 2
63	Note 26.13	-	-	-	-	0x37	Keyboard Scan Code – Break Byte 3
64	Note 26.13	Note 26.9	Note 26.9	Note 26.9	-	Note 26.9	Keyboard PWRBTN/SPEKEY
65	R/W	0x00	0x00	0x00	-	-	WDT_TIME_OUT
66	R/W	0x00	0x00	0x00	-	-	WDT_VAL
67	R/W	0x00	0x00	0x00	-	-	WDT_CFG
68	R/W Note 26.15	0x00 Note 26.14	0x00	0x00	-	-	WDT_CTRL
69	R	-	-	-	-	-	Reserved – reads return 0
6A	R	-	-	-	-	-	Reserved – reads return 0
6B	R	-	-	-	-	-	Reserved – reads return 0
6C	R	-	-	-	-	-	Reserved – reads return 0

Table 26.2 Runtime Register POR Summary (continued)

REGISTER OFFSET (HEX)	TYPE	PCI RESET	VCC POR	VTR POR	SOFT RESET	VBAT POR	REGISTER
6D	R/W	-	-	-	-	0x00	TEST
6E	R/W	-	-	0x00	-	-	GP44 (SCH3112 and SCH3114)
6E	R/W	-	-	0x01	-	-	GP44 (SCH3116)
6F	R/W	-	-	0x00	-	-	GP45 (SCH3112 and SCH3114)
6F	R/W	-	-	0x01	-	-	GP45 (SCH3116)
70	R/W	-	-	0x00	-	-	HWM Index Register
71	R/W	-	-	0x00	-	-	HWM Data Register
72	R/W	-	-	0x00	-	-	GP46 (SCH3112 and SCH3114)
72	R/W	-	-	0x01	-	-	GP46 (SCH3116)
73	R/W	-	-	0x00	-	-	GP47 (SCH3112 and SCH3114)
73	R/W	-	-	0x01	-	-	GP47 (SCH3116)
74-7Fh	R	-	-	-	-	-	Reserved – reads return 0

Note 26.1 Bit 3 of the PME_STS5 register may be set on a VCC POR. If GP53 are configured as input, then their corresponding PME and SMI status bits will be set on a VCC POR.

Note 26.2 This register does not support the Power failure recovery status.

Note 26.3 This register supports ring indicator status bits for serial ports 3-6 if required by the particular device.

Note 26.4 This register supports additional UART interrupt status bits for serial ports 3-6 if required by the particular device

Note 26.5 This register supports alternate functions for serial port 3.

Note 26.6 This register supports alternate functions for serial port 4.

Note 26.7 This register supports alternate functions for pci reset outputs.

Note 26.8 This register supports alternate functions for serial port 6.

Note 26.9 See the register description for the default value.

Note 26.10 Bit[0] cannot be written to '1'. Bit[1] and Bit[7] are read-only.

Note 26.11 This register is a read/write register when bit[7]=0, except bit[4]. Bit[4] is a read-only bit. This register is a read-only register when bit[7]=1.

Note 26.12 This is a binary number. The x's denote a bit that is not affected by the reset condition.

Note 26.13 This register is read/write when Bit [7] Keyboard PWRBTN/SPEKEY Lock of the Keyboard PWRBTN/SPEKEY register at offset 64h is set to '0' and Read-Only when Bit [7] is set to '1'.

Datasheet

Note 26.14 Bit 0 is not cleared by PCI RESET.

Note 26.15 This register contains some bits that are read or write only.

Note 26.16 See the register description for the bit-wise access type.

Note 26.17 This register is read/write when Bit [7] in the [Mouse_Specific_Wake](#) Register is set to '0' and Read-Only when Bit [7] is set to '1'.

26.2 Runtime Register Description

The following registers are located at an offset from (PME_BLK) the address programmed into the base I/O address register for Logical Device A.

Table 26.3 Detailed Runtime Register Description

NAME	REG OFFSET (HEX)	DESCRIPTION
PME_STS Default = 0x00 on VTR POR	00 (R/WC)	PME Pin Status Register Bit[0] PME_Status = 0 (default) = 1 Autonomously Set when a wakeup event occurs that normally asserts the nIO_PME signal. This bit is set independent of the state of the PME_EN bit Bit[7:1] Reserved PME_Status is not affected by Vcc POR, SOFT RESET or PCI RESET. Writing a "1" to PME_Status will clear it and cause the device to stop asserting nIO_PME, in enabled. Writing a "0" to PME_Status has no effect.
PME_EN Default = 0x00 on VTR POR	02 (R/W)	PME Pin Enable Register Bit[0] PME_En = 0 nIO_PME signal assertion is disabled (default) = 1 Enables this device to assert nIO_PME signal Bit[7:1] Reserved PME_En is not affected by Vcc POR, SOFT RESET or PCI RESET
PME_STS1 Default = 0x00 on VTR POR	04 (R/WC)	PME Wake Status Register 1 This register indicates the state of the individual PME wake sources, independent of the individual source enables or the PME_EN bit. If the wake source has asserted a wake event, the associated PME Wake Status bit will be a "1". If enabled, any set bit in this register asserts the nIO_PME pin. Bit[0] HW_Monitor Bit[1] RI2 Bit[2] RI1 Bit[3] KBD Bit[4] MOUSE Bit[5] Reserved Bit[6] IRINT. This bit is set by a transition on the IR pin (IRRX) Bit[7] Reserved The PME Wake Status register is not affected by Vcc POR, SOFT RESET or PCI RESET. Writing a "1" to Bit[7:0] will clear it. Writing a "0" to any bit in PME Wake Status Register has no effect.

Table 26.3 Detailed Runtime Register Description (continued)

NAME	REG OFFSET (HEX)	DESCRIPTION
PME_STS3 Default = 0x00 on VTR POR	05 (R/WC)	<p>PME Wake Status Register 3</p> <p>This register indicates the state of the individual PME wake sources, independent of the individual source enables or the PME_EN bit. If the wake source has asserted a wake event, the associated PME Wake Status bit will be a "1". If enabled, any set bit in this register asserts the nIO_PME pin.</p> <p>Bit[0] WDT Bit[1] GP21 Bit[2] GP22 Bit[3] DEVINT_STS (status of group SMI signal for PME) Bit[4] GP27 Bit[5] GP32 Bit[6] GP33 Bit[7] Reserved</p> <p>The PME Wake Status register is not affected by Vcc POR, SOFT RESET or PCI RESET. Writing a "1" to Bit[7:0] will clear it. Writing a "0" to any bit in PME Wake Status Register has no effect.</p>
PME_STS5 Default = 0x00 on VTR POR	06 (R/WC)	<p>PME Wake Status Register 5</p> <p>This register indicates the state of the individual PME wake sources, independent of the individual source enables or the PME_EN bit. If the wake source has asserted a wake event, the associated PME Wake Status bit will be a "1". If enabled, any set bit in this register asserts the nIO_PME pin.</p> <p>Bit[0] GP50 Bit[1] GP51 Bit[2] GP52 Bit[3] GP53 Bit[4] GP54 Bit[5] GP55 Bit[6] GP56 Bit[7] GP57</p> <p>The PME Wake Status register is not affected by Vcc POR, SOFT RESET or PCI RESET. Writing a "1" to Bit[7:0] will clear it. Writing a "0" to any bit in PME Wake Status Register has no effect.</p>
PME_STS6 Default = 0x00 or 0x01 on VTR POR The default will be 0x01 if there is a LOW_BAT event under VBAT power only, 0x00 if the event does not occurs. Bit[0] will be set to '1' on a VCC POR if the battery voltage drops below 2.4V under VTR power (VCC=0) or under battery power only. SCH3112, SCH3114 DEVICES	07 (R/WC)	<p>This register indicates the state of the individual PME sources, independent of the individual source enables or the PME_EN bit. If the wake source has asserted a wake event, the associated PME Wake Status bit will be a "1". If enabled, any set bit in this register asserts the nIO_PME pin.</p> <p>Bit[0] LOW_BAT, Cleared by a write of '1'. When the battery is removed and replaced or the if the battery voltage drops below 1.2V under battery power, then the LOW_BAT PME status bit is set on VTR POR. When the battery voltage drops below 2.4 volts under VTR power (VCC=0) or under battery power only, the LOW_BAT PME status bit is set on VCC POR. The corresponding enable bit must be set to generate a PME. The low battery event is not a PME wakeup event.</p> <p>Bit[1] RESERVED. Bit[2] GP60 Bit[3] GP61 Bit[4] SPEMSE_STS (Wake on specific mouse click) Bit[5] SPEKEY_STS (Wake on specific key) Bit[6] PB_STS</p> <p>Bit[7] PFR_STS Power Failure Recovery Status</p> <p>The PME Status register is not affected by VCC POR, SOFT RESET or PCI RESET. Writing a "1" to Bit[7:0] will clear it. Writing a "0" to any bit in PME Status Register has no effect.</p>

Table 26.3 Detailed Runtime Register Description (continued)

NAME	REG OFFSET (HEX)	DESCRIPTION
<p>PME_STS6</p> <p>Default = 0x00 or 0x01 on VTR POR</p> <p>The default will be 0x01 if there is a LOW_BAT event under_VBAT power only, 0x00 if the event does not occurs.</p> <p>Bit[0] will be set to '1' on a VCC POR if the battery voltage drops below 2.4V under VTR power (VCC=0) or under battery power only.</p> <p>SCH3116 DEVICE ONLY</p>	<p>07</p> <p>(R/WC)</p>	<p>This register indicates the state of the individual PME sources, independent of the individual source enables or the PME_EN bit. If the wake source has asserted a wake event, the associated PME Wake Status bit will be a "1". If enabled, any set bit in this register asserts the nIO_PME pin.</p> <p>Bit[0] LOW_BAT, Cleared by a write of '1'. When the battery is removed and replaced or the if the battery voltage drops below 1.2V under battery power, then the LOW_BAT PME status bit is set on VTR POR. When the battery voltage drops below 2.4 volts under VTR power (VCC=0) or under battery power only, the LOW_BAT PME status bit is set on VCC POR. The corresponding enable bit must be set to generate a PME. The low battery event is not a PME wakeup event.</p> <p>Bit[1] RESERVED. Bit[2] GP60 Bit[3] GP61 Bit[4] SPEMSE_STS (Wake on specific mouse click) Bit[5] SPEKEY_STS (Wake on specific key) Bit[6] PB_STS</p> <p>Bit[7] Reserved</p> <p>The PME Status register is not affected by VCC POR, SOFT RESET or PCI RESET. Writing a "1" to Bit[7:0] will clear it. Writing a "0" to any bit in PME Status Register has no effect.</p>
<p>PME_EN1</p> <p>Default = 0x00 on VTR POR</p>	<p>08</p> <p>(R/W)</p>	<p>PME Wake Enable Register 1</p> <p>This register is used to enable individual PME wake sources onto the nIO_PME wake bus. When the PME Wake Enable register bit for a wake source is active ("1"), if the source asserts a wake event so that the associated status bit is "1" and the PME_EN bit is "1", the source will assert the nIO_PME signal. When the PME Wake Enable register bit for a wake source is inactive ("0"), the PME Wake Status register will indicate the state of the wake source but will not assert the nIO_PME signal.</p> <p>Bit[0] HW_Monitor Bit[1] RI2 Bit[2] RI1 Bit[3] KBD Bit[4] MOUSE Bit[5] Reserved Bit[6] IRINT Bit[7] Reserved</p> <p>The PME Wake Enable register is not affected by Vcc POR, SOFT RESET or PCI RESET.</p>

Table 26.3 Detailed Runtime Register Description (continued)

NAME	REG OFFSET (HEX)	DESCRIPTION
PME_EN3 Default = 0x00 on VTR POR	09 (R/W)	<p>PME Wake Status Register 3 This register is used to enable individual PME wake sources onto the nIO_PME wake bus. When the PME Wake Enable register bit for a wake source is active ("1"), if the source asserts a wake event so that the associated status bit is "1" and the PME_EN bit is "1", the source will assert the nIO_PME signal. When the PME Wake Enable register bit for a wake source is inactive ("0"), the PME Wake Status register will indicate the state of the wake source but will not assert the nIO_PME signal.</p> <p>Bit[0] WDT Bit[1] GP21 Bit[2] GP22 Bit[3] DEVINT_EN (Enable bit for group SMI signal for PME) Bit[4] GP27 Bit[5] GP32 Bit[6] GP33 Bit[7] Reserved</p> <p>The PME Wake Enable register is not affected by Vcc POR, SOFT RESET or PCI RESET.</p>
PME_EN5 Default = 0x00 on VTR POR	0A (R/W)	<p>PME Wake Enable Register 5 This register is used to enable individual PME wake sources onto the nIO_PME wake bus. When the PME Wake Enable register bit for a wake source is active ("1"), if the source asserts a wake event so that the associated status bit is "1" and the PME_EN bit is "1", the source will assert the nIO_PME signal. When the PME Wake Enable register bit for a wake source is inactive ("0"), the PME Wake Status register will indicate the state of the wake source but will not assert the nIO_PME signal.</p> <p>Bit[0] GP50 Bit[1] GP51 Bit[2] GP52 Bit[3] GP53 Bit[4] GP54 Bit[5] GP55 Bit[6] GP56 Bit[7] GP57</p> <p>The PME Wake Enable register is not affected by Vcc POR, SOFT RESET or PCI RESET.</p>
PME_EN6 Default = 0x00 on VTR POR SCH3112, SCH3114 DEVICES ONLY NOTE: Bit 7 of this register needs to be VBAT powered	0B (R/W)	<p>PME Enable Register 6 This register is used to enable individual PME sources onto the nIO_PME signal. When the PME Enable register bit for a PME source is active ("1"), if the source asserts a PME event and the PME_EN bit is "1", the source will assert the nIO_PME signal. When the PME Enable register bit for a PME source is inactive ("0"), the PME Status register will indicate the state of the PME source but will not assert the nIO_PME signal.</p> <p>Bit[0] LOW_BAT Bit[1] Reserved Bit[2] GP60 Bit[3] GP61 Bit[4] SPEMSE_EN (Wake on specific mouse click) Bit[5] SPEKEY_EN (Wake on specific key) Bit[6] PB_EN</p> <p>Bit[7] PFR_STS Power Failure Recovery Enable</p> <p>The PME Enable register 6 is not affected by VCC POR, SOFT RESET or PCI RESET.</p>

Table 26.3 Detailed Runtime Register Description (continued)

NAME	REG OFFSET (HEX)	DESCRIPTION
PME_EN6 Default = 0x00 on VTR POR SCH3116 DEVICE ONLY NOTE: Bit 7 of this register needs to be VBAT powered	0B (R/W)	PME Enable Register 6 This register is used to enable individual PME sources onto the nIO_PME signal. When the PME Enable register bit for a PME source is active ("1"), if the source asserts a PME event and the PME_EN bit is "1", the source will assert the nIO_PME signal. When the PME Enable register bit for a PME source is inactive ("0"), the PME Status register will indicate the state of the PME source but will not assert the nIO_PME signal. Bit[0] LOW_BAT Bit[1] Reserved Bit[2] GP60 Bit[3] GP61 Bit[4] SPEMSE_EN (Wake on specific mouse click) Bit[5] SPEKEY_EN (Wake on specific key) Bit[6] PB_EN Bit[7] Reserved The PME Enable register 6 is not affected by VCC POR, SOFT RESET or PCI RESET.
PME_STS7 Default = 0x00 on VTR POR SCH3112 DEVICE ONLY	0C (R/WC)	RESERVED Bit[7:0] Reserved
PME_STS7 Default = 0x00 on VTR POR SCH3114 DEVICE ONLY	0C (R/WC)	PME Wake Status Register 7 This register indicates the state of the individual PME wake sources, independent of the individual source enables or the PME_EN bit. If the wake source has asserted a wake event, the associated PME Wake Status bit will be a "1". If enabled, any set bit in this register asserts the nIO_PME pin. Bit[0] RI3 Bit[1] RI4 Bit[2] Reserved Bit[3] Reserved Bit[4] Reserved Bit[5] Reserved Bit[6] Reserved Bit[7] Reserved The PME Wake Status register is not affected by Vcc POR, SOFT RESET or PCI RESET. Writing a "1" to Bit[7:0] will clear it. Writing a "0" to any bit in PME Wake Status Register has no effect.

Table 26.3 Detailed Runtime Register Description (continued)

NAME	REG OFFSET (HEX)	DESCRIPTION
PME_STS7 Default = 0x00 on VTR POR SCH3116 DEVICE ONLY	0C (R/WC)	<p>PME Wake Status Register 7</p> <p>This register indicates the state of the individual PME wake sources, independent of the individual source enables or the PME_EN bit. If the wake source has asserted a wake event, the associated PME Wake Status bit will be a "1". If enabled, any set bit in this register asserts the nIO_PME pin.</p> <p>Bit[0] RI3 Bit[1] RI4 Bit[2] RI5 Bit[3] RI6 Bit[4] Reserved Bit[5] Reserved Bit[6] Reserved Bit[7] Reserved</p> <p>The PME Wake Status register is not affected by Vcc POR, SOFT RESET or PCI RESET. Writing a "1" to Bit[7:0] will clear it. Writing a "0" to any bit in PME Wake Status Register has no effect.</p>
PME_EN7 Default = 0x00 on Vbat POR SCH3112 DEVICE ONLY	10 (R/W)	<p>RESERVED</p> <p>Bit[7:0] Reserved</p>
PME_EN7 Default = 0x00 on Vbat POR SCH3114 DEVICE ONLY	10 (R/W)	<p>PME Wake Enable Register 1</p> <p>This register is used to enable individual PME wake sources onto the nIO_PME wake bus.</p> <p>When the PME Wake Enable register bit for a wake source is active ("1"), if the source asserts a wake event so that the associated status bit is "1" and the PME_EN bit is "1", the source will assert the nIO_PME signal. When the PME Wake Enable register bit for a wake source is inactive ("0"), the PME Wake Status register will indicate the state of the wake source but will not assert the nIO_PME signal.</p> <p>Bit[0] RI3 Bit[1] RI4 Bit[2] Reserved Bit[3] Reserved Bit[4] Reserved Bit[5] Reserved Bit[6] Reserved Bit[7] Reserved</p> <p>The PME Wake Enable register is not affected by Vcc POR, SOFT RESET or PCI RESET.</p>

Table 26.3 Detailed Runtime Register Description (continued)

NAME	REG OFFSET (HEX)	DESCRIPTION
PME_EN7 Default = 0x00 on Vbat POR SCH3116 DEVICE ONLY	10 (R/W)	PME Wake Enable Register 1 This register is used to enable individual PME wake sources onto the nIO_PME wake bus. When the PME Wake Enable register bit for a wake source is active ("1"), if the source asserts a wake event so that the associated status bit is "1" and the PME_EN bit is "1", the source will assert the nIO_PME signal. When the PME Wake Enable register bit for a wake source is inactive ("0"), the PME Wake Status register will indicate the state of the wake source but will not assert the nIO_PME signal. Bit[0] RI3 Bit[1] RI4 Bit[2] RI5 Bit[3] RI6 Bit[4] Reserved Bit[5] Reserved Bit[6] Reserved Bit[7] Reserved The PME Wake Enable register is not affected by Vcc POR, SOFT RESET or PCI RESET.
SP12 Option Default = 0x44 on VTR POR	0x12 (R/W)	SP Options for SP1 and SP2 Bit[0] Automatic Direction Control Select SP1 1=FC on 0=FC off Bits[1] Signal select SP1 1=nRTS control 0=nDTR control Bits[2] Polarity SP1 0= Drive low when enabled 1= Drive 1 when enabled Bits[3] RESERVED Bit[4] Automatic Direction Control Select SP2 1=FC on 0=FC off Bits[5] Signal select SP2 1=nRTS control 0=nDTR control Bits[6] Polarity SP2 0= Drive low when enabled 1= Drive 1 when enabled Bits[7] RESERVED
SP34 Option Default = 0x44 on VTR POR THIS REGISTER IS RESERVED FOR SCH3112 DEVICE	0x13 (R/W)	SCH3112 DEVICE Bits[7:0] RESERVED

Table 26.3 Detailed Runtime Register Description (continued)

NAME	REG OFFSET (HEX)	DESCRIPTION
SP34 Option Default = 0x44 on VTR POR SCH3114 AND SCH3116 DEVICE ONLY.	0x13 (R/W)	SCH3114 AND SCH3116 DEVICE SP Options for SP3 and SP4 Bit[0] Automatic Direction Control Select SP3 1=FC on 0=FC off Bits[1] Signal select SP3 1=nRTS control 0=nDTR control Bits[2] Polarity SP3 0= Drive low when enabled 1= Drive 1 when enabled Bits[3] RESERVED Bit[4] Automatic Direction Control Select SP4 1=FC on 0=FC off Bits[5] Signal select SP4 1=nRTS control 0=nDTR control Bits[6] Polarity SP4 0= Drive low when enabled 1= Drive 1 when enabled Bits[7] RESERVED
SMI_STS1 Default = 0x02, or 0x03 On VTR POR. The default will be 0x03 if there is a LOW_BAT event under VBAT power only, or 0x02 if this event does not occur. Bit 0 will be set to '1' on a VCC POR if the battery voltage drops below 2.4V under VTR power (VCC=0) or under battery power only. Bit 1 is set to '1' on VCC POR, VTR POR, PCI Reset and soft reset.	14 Bits[0] are R/WC. Bits[1:4,7] are RO.	SMI Status Register 1 This register is used to read the status of the SMI inputs. The following bits must be cleared at their source except as shown. Bit[0] LOW_BAT. Cleared by a write of '1'. When the battery is removed and replaced or if the battery voltage drops below 1.2V (nominal) under battery power only (VBAT POR), then the LOW_BAT SMI status bit is set on VTR POR. When the battery voltage drops below 2.4 volts (nominal) under VTR power (VCC=0) or under battery power only, the LOW_BAT SMI status bit is set on VCC POR. Bit[1] PINT. The parallel port interrupt defaults to '1' when the parallel port activate bit is cleared. When the parallel port is activated, PINT follows the nACK input. Bit[2] U2INT Bit[3] U1INT Bit[4] FINT Bit[5] Reserved Bit[6] Reserved Bit[7] WDT
SMI_STS2 Default = 0x00 on VTR POR	15 (R/W) Bits[0,1] are RO Bits[2] is Read-Clear.	SMI Status Register 2 This register is used to read the status of the SMI inputs. Bit[0] MINT. Cleared at source. Bit[1] KINT. Cleared at source. Bit[2] IRINT. This bit is set by a transition on the IR pin (IRRX). Cleared by a read of this register. Bit[3] Reserved Bit[4] SPEMSE_STS (Wake on specific mouse click) - Cleared by writing a '1' Bit[7:5] Reserved

Table 26.3 Detailed Runtime Register Description (continued)

NAME	REG OFFSET (HEX)	DESCRIPTION
SMI_STS3 Default = 0x00 on VTR POR	16 (R/WC)	SMI Status Register 3 This register is used to read the status of the SMI inputs. The following bits are cleared on a write of '1'. Bit[0] Reserved Bit[1] GP21 Bit[2] GP22 Bit[3] GP54 Bit[4] GP55 Bit[5] GP56 Bit[6] GP57 Bit[7] GP60
SMI_STS4 Default = 0x00 on VTR POR (Note 26.23) SCH3112 DEVICE ONLY	17 (R/WC)	SCH3112 Device SMI Status Register 4 This register is used to read the status of the SMI inputs. The following bits are cleared on a write of '1'. Bit[0] RESERVED Bit[1] RESERVED Bit[2] GP32 Bit[3] GP33 Bit[4] RESERVED Bit[5] GP42 Bit[6] RESERVED Bit[7] GP61
SMI_STS4 Default = 0x00 on VTR POR (Note 26.23) SCH3114 DEVICE ONLY	17 (R/WC)	SCH3114 Device Only: SMI Status Register 4 This register is used to read the status of the SMI inputs. The following bits are cleared on a write of '1'. Bit[0] U3INT Bit[1] U4INT Bit[2] GP32 Bit[3] GP33 Bit[4] RESERVED Bit[5] GP42 Bit[6] RESERVED Bit[7] GP61
SMI_STS4 Default = 0x00 on VTR POR (Note 26.23) SCH3116 DEVICE ONLY	17 (R/WC)	SCH3116 Device Only: SMI Status Register 4 This register is used to read the status of the SMI inputs. The following bits are cleared on a write of '1'. Bit[0] U3INT Bit[1] U4INT Bit[2] GP32 Bit[3] GP33 Bit[4] U5INT Bit[5] GP42 Bit[6] U6INT Bit[7] GP61
SMI_EN1 Default = 0x00 On VTR POR	18 (R/W)	SMI Enable Register 1 This register is used to enable the different interrupt sources onto the group nIO_SMI output. 1=Enable 0=Disable Bit[0] EN_LOW_BAT Bit[1] EN_PINT Bit[2] EN_U2INT Bit[3] EN_U1INT Bit[4] EN_FINT Bit[5] Reserved Bit[6] Reserved Bit[7] EN_WDT

Table 26.3 Detailed Runtime Register Description (continued)

NAME	REG OFFSET (HEX)	DESCRIPTION
SMI_EN2 Default = 0x00 on VTR POR	19 (R/W)	SMI Enable Register 2 This register is used to enable the different interrupt sources onto the group nSMI output, and the group nSMI output onto the nIO_SMI GPI/O pin, the serial IRQ stream or into the PME Logic. Unless otherwise noted, 1=Enable 0=Disable Bit[0] EN_MINT Bit[1] EN_KINT Bit[2] EN_IRINT Bit[3] Reserved Bit[4] EN_SPESME Bit[5] EN_SMI_PME (Enable group SMI into PME logic) Bit[6] EN_SMI_S (Enable group SMI onto serial IRQ) Bit[7] EN_SMI (Enable group SMI onto nIO_SMI pin)
SMI_EN3 Default = 0x00 on VTR POR	1A (R/W)	SMI Enable Register 3 This register is used to enable the different interrupt sources onto the group nSMI output. 1=Enable 0=Disable Bit[0] Reserved Bit[1] GP21 Bit[2] GP22 Bit[3] GP54 Bit[4] GP55 Bit[5] GP56 Bit[6] GP57 Bit[7] GP60
SMI_EN4 Default = 0x00 on VTR POR THIS IS FOR THE SCH3112 DEVICE ONLY	1B (R/W)	SCH3112 Device SMI Status Register 4 This register is used to read the status of the SMI inputs. The following bits are cleared on a write of '1'. Bit[0] RESERVED Bit[1] RESERVED Bit[2] GP32 Bit[3] GP33 Bit[4] RESERVED Bit[5] GP42 Bit[6] RESERVED Bit[7] GP61
SMI_EN4 Default = 0x00 on VTR POR THIS IS FOR THE SCH3114 DEVICE ONLY	1B (R/W)	SCH3114 Device Only: SMI Status Register 4 This register is used to read the status of the SMI inputs. The following bits are cleared on a write of '1'. Bit[0] U3INT Bit[1] U4INT Bit[2] GP32 Bit[3] GP33 Bit[4] RESERVED Bit[5] GP42 Bit[6] RESERVED Bit[7] GP61

Table 26.3 Detailed Runtime Register Description (continued)

NAME	REG OFFSET (HEX)	DESCRIPTION
SMI_EN4 Default = 0x00 on VTR POR THIS IS FOR THE SCH3116 DEVICE ONLY	1B (R/W)	SCH3116 Device Only: SMI Enable Register 4 This register is used to enable the different interrupt sources onto the group nSMI output. 1=Enable 0=Disable Bit[0] EN_U3INT Bit[1] EN_U4INT Bit[2] GP32 Bit[3] GP33 Bit[4] EN_U5INT Bit[5] GP42 Bit[6] EN_U6INT Bit[7] GP61
MSC_STS Default = 0x00 on VTR POR	1C (R/W)	Miscellaneous Status Register Bits[5:0] can be cleared by writing a 1 to their position (writing a 0 has no effect). Bit[0] Either Edge Triggered Interrupt Input 0 Status. This bit is set when an edge occurs on the GP21 pin. Bit[1] Either Edge Triggered Interrupt Input 1 Status. This bit is set when an edge occurs on the GP22 pin. Bit[2] Reserved Bit[3] Reserved Bit[4] Either Edge Triggered Interrupt Input 4 Status. This bit is set when an edge occurs on the GP60 pin. Bit[5] Either Edge Triggered Interrupt Input 5 Status. This bit is set when an edge occurs on the GP61 pin. Bit[7:6] Reserved. This bit always returns zero.
RESGEN VTR POR default = 00h	1Dh (R/W)	Reset Generator Bit[0] WDT2_EN: Enable Watchdog timer Generation / Select 0= WDT Disabled - not source for PWRGD_OUT (Default) 1= WDT Enabled - Source for PWRGD_OUT Bit[1] ThermTrip Source Select 0 = Thermtrip not source for PWRGD_OUT ((Default) 1 = Thermtrip source for PWRGD_OUT Bit[2] WDT2_CTL: WDT input bit Bit[7:3] Reserved
Force Disk Change Default = 0x03 on VCC POR, PCI Reset and VTR POR	1E (R/W)	Force Disk Change Bit[0] Force Disk Change for FDC0 0=Inactive 1=Active Bit[1] Force Disk Change for FDC1 0=Inactive 1=Active Force Change 0 and 1 can be written to 1 but are not clearable by software. Force Change 0 is cleared on nSTEP and nDS0 Force Change 1 is cleared on nSTEP and nDS1 DSKCHG (FDC DIR Register, Bit 7) = (nDS0 AND Force Change 0) OR (nDS1 AND Force Change 1) OR nDSKCHG Setting either of the Force Disk Change bits active '1' forces the FDD nDSKCHG input active when the appropriate drive has been selected. Bit[7:2] Reserved

Table 26.3 Detailed Runtime Register Description (continued)

NAME	REG OFFSET (HEX)	DESCRIPTION
Floppy Data Rate Select Shadow	1F (R)	Floppy Data Rate Select Shadow Bit[0] Data Rate Select 0 Bit[1] Data Rate Select 1 Bit[2] PRECOMP 0 Bit[3] PRECOMP 1 Bit[4] PRECOMP 2 Bit[5] Reserved Bit[6] Power Down Bit[7] Soft Reset
UART1 FIFO Control Shadow	20 (R)	UART FIFO Control Shadow 1 Bit[0] FIFO Enable Bit[1] RCVR FIFO Reset Bit[2] XMIT FIFO Reset Bit[3] DMA Mode Select Bit[5:4] Reserved Bit[6] RCVR Trigger (LSB) Bit[7] RCVR Trigger (MSB)
UART2 FIFO Control Shadow	21 (R)	UART FIFO Control Shadow 2 Bit[0] FIFO Enable Bit[1] RCVR FIFO Reset Bit[2] XMIT FIFO Reset Bit[3] DMA Mode Select Bit[5:4] Reserved Bit[6] RCVR Trigger (LSB) Bit[7] RCVR Trigger (MSB)
UART3 FIFO Control Shadow THIS REGISTER IS RESERVED FOR SCH3112 DEVICE	22 (R)	SCH3112 DEVICE Bits[7:0] RESERVED
UART3 FIFO Control Shadow SCH3114 AND SCH3116 DEVICE ONLY.	22 (R)	SCH3114 AND SCH3116 DEVICE UART FIFO Control Shadow 3 Bit[0] FIFO Enable Bit[1] RCVR FIFO Reset Bit[2] XMIT FIFO Reset Bit[3] DMA Mode Select Bit[5:4] Reserved Bit[6] RCVR Trigger (LSB) Bit[7] RCVR Trigger (MSB)
GP10 Default = 0x01 on VTR POR SCH3112 DEVICE ONLY	23 (R/W)	General Purpose I/O bit 1.0 Bit[0] In/Out : =1 Input, =0 Output Bit[1] Polarity : =1 Invert, =0 No Invert Bits[6:2] Reserved Bit[7] Output Type Select 1=Open Drain 0=Push Pull
GP10 Default = 0x01 on VTR POR SCH3114,SCH3116 DEVICES ONLY	23 (R/W)	General Purpose I/O bit 1.0 Bit[0] In/Out : =1 Input, =0 Output Bit[1] Polarity : =1 Invert, =0 No Invert Bit[2] Alternate Function Select 1= RXD3 0=GP10 Bits[6:3] Reserved Bit[7] Output Type Select 1=Open Drain 0=Push Pull

Table 26.3 Detailed Runtime Register Description (continued)

NAME	REG OFFSET (HEX)	DESCRIPTION
GP11 Default = 0x01 on VTR POR SCH3112 DEVICE ONLY	24 (R/W)	General Purpose I/O bit 1.1 Bit[0] In/Out : =1 Input, =0 Output Bit[1] Polarity : =1 Invert, =0 No Invert Bits[6:2] Reserved Bit[7] Output Type Select 1=Open Drain 0=Push Pull
GP11 Default = 0x01 on VTR POR SCH3114,SCH3116 DEVICES ONLY	24 (R/W)	General Purpose I/O bit 1.1 Bit[0] In/Out : =1 Input, =0 Output Bit[1] Polarity : =1 Invert, =0 No Invert Bit[2] Alternate Function Select 1=TXD3 0=GP11 Bits[6:3] Reserved Bit[7] Output Type Select 1=Open Drain 0=Push Pull
GP12 Default = 0x01 on VTR POR SCH3112 DEVICE ONLY	25 (R/W)	General Purpose I/O bit 1.2 Bit[0] In/Out : =1 Input, =0 Output Bit[1] Polarity : =1 Invert, =0 No Invert Bits[6:2] Reserved Bit[7] Output Type Select 1=Open Drain 0=Push Pull
GP12 Default = 0x01 on VTR POR SCH3114,SCH3116 DEVICES ONLY	25 (R/W)	General Purpose I/O bit 1.2 Bit[0] In/Out : =1 Input, =0 Output Bit[1] Polarity : =1 Invert, =0 No Invert Bit[2] Alternate Function Select 1= nDCD3 0=GP12 Bits[6:3] Reserved Bit[7] Output Type Select 1=Open Drain 0=Push Pull
GP13 Default = 0x01 on VTR POR SCH3112 DEVICE ONLY	26 (R/W)	General Purpose I/O bit 1.3 Bit[0] In/Out : =1 Input, =0 Output Bit[1] Polarity : =1 Invert, =0 No Invert Bits[6:2] Reserved Bit[7] Output Type Select 1=Open Drain 0=Push Pull
GP13 Default = 0x01 on VTR POR SCH3114,SCH3116 DEVICES ONLY	26 (R/W)	General Purpose I/O bit 1.3 Bit[0] In/Out : =1 Input, =0 Output Bit[1] Polarity : =1 Invert, =0 No Invert Bit[2] Alternate Function Select 1= nRI3 0=GP13 Bits[6:3] Reserved Bit[7] Output Type Select 1=Open Drain 0=Push Pull

Table 26.3 Detailed Runtime Register Description (continued)

NAME	REG OFFSET (HEX)	DESCRIPTION
GP14 Default = 0x01 on VTR POR SCH3112 DEVICE ONLY	27 (R/W)	General Purpose I/O bit 1.1 Bit[0] In/Out : =1 Input, =0 Output Bit[1] Polarity : =1 Invert, =0 No Invert Bits[6:2] Reserved Bit[7] Output Type Select 1=Open Drain 0=Push Pull
GP14 Default = 0x01 on VTR POR SCH3114,SCH3116 DEVICES ONLY	27 (R/W)	General Purpose I/O bit 1.1 Bit[0] In/Out : =1 Input, =0 Output Bit[1] Polarity : =1 Invert, =0 No Invert Bit[2] Alternate Function Select 1= nDSR3 0=GP14 Bits[6:3] Reserved Bit[7] Output Type Select 1=Open Drain 0=Push Pull
UART4 FIFO Control Shadow THIS REGISTER IS RESERVED FOR SCH3112 DEVICE	28 (R)	SCH3112 DEVICE Bits[7:0] RESERVED
UART4 FIFO Control Shadow SCH3114 AND SCH3116 DEVICE ONLY.	28 (R)	SCH3114 AND SCH3116 DEVICE UART FIFO Control Shadow 4 Bit[0] FIFO Enable Bit[1] RCVR FIFO Reset Bit[2] XMIT FIFO Reset Bit[3] DMA Mode Select Bit[5:4] Reserved Bit[6] RCVR Trigger (LSB) Bit[7] RCVR Trigger (MSB)
GP15 Default = 0x01 on VTR POR SCH3112 DEVICE ONLY	29 (R/W)	General Purpose I/O bit 1.1 Bit[0] In/Out : =1 Input, =0 Output Bit[1] Polarity : =1 Invert, =0 No Invert Bits[6:2] Reserved Bit[7] Output Type Select 1=Open Drain 0=Push Pull
GP15 Default = 0x01 on VTR POR SCH3114,SCH3116 DEVICES ONLY	29 (R/W)	General Purpose I/O bit 1.1 Bit[0] In/Out : =1 Input, =0 Output Bit[1] Polarity : =1 Invert, =0 No Invert Bit[2] Alternate Function Select 1= nDTR3 0=GP15 Bits[6:3] Reserved Bit[7] Output Type Select 1=Open Drain 0=Push Pull
GP16 Default = 0x01 on VTR POR SCH3112 DEVICE ONLY	2A (R/W)	General Purpose I/O bit 1.1 Bit[0] In/Out : =1 Input, =0 Output Bit[1] Polarity : =1 Invert, =0 No Invert Bits[6:2] Reserved Bit[7] Output Type Select 1=Open Drain 0=Push Pull

Table 26.3 Detailed Runtime Register Description (continued)

NAME	REG OFFSET (HEX)	DESCRIPTION
GP16 Default = 0x01 on VTR POR SCH3114,SCH3116 DEVICES ONLY	2A (R/W)	General Purpose I/O bit 1.1 Bit[0] In/Out : =1 Input, =0 Output Bit[1] Polarity : =1 Invert, =0 No Invert Bit[2] Alternate Function Select 1= nCTS3 0=GP16 Bits[6:3] Reserved Bit[7] Output Type Select 1=Open Drain 0=Push Pull
GP17 Default = 0x01 on VTR POR SCH3112 DEVICE ONLY	2B (R/W)	General Purpose I/O bit 1.1 Bit[0] In/Out : =1 Input, =0 Output Bit[1] Polarity : =1 Invert, =0 No Invert Bits[6:2] Reserved Bit[7] Output Type Select 1=Open Drain 0=Push Pull
GP17 Default = 0x01 on VTR POR SCH3114,SCH3116 DEVICES ONLY	2B (R/W)	General Purpose I/O bit 1.1 Bit[0] In/Out : =1 Input, =0 Output Bit[1] Polarity : =1 Invert, =0 No Invert Bit[2] Alternate Function Select 1= nRTS3 0=GP17 Bits[6:4] Reserved Bit[7] Output Type Select 1=Open Drain 0=Push Pull
GP21 Default =0x8C on VTR POR	2C (R/W)	General Purpose I/O bit 2.1 Bit[0] In/Out : =1 Input, =0 Output Bit[1] Polarity : =1 Invert, =0 No Invert Bit[3:2] Alternate Function Select 11= KDAT (Default) 10=Either Edge Triggered Interrupt Input 0 (Note 26.20) 01=Reserved 00=Basic GPIO function Bits[6:4] Reserved Bit[7] Output Type Select 1=Open Drain 0=Push Pull (Default) APPLICATION NOTE: When Bits[3:2] are programmed to '11' to select the KDAT function, bit[0] should always be programmed to '0'. The KDAT function will not operate properly when bit[0] is set.
GP22 Default =0x8C on VTR POR	2D (R/W)	General Purpose I/O bit 2.2 Bit[0] In/Out : =1 Input, =0 Output Bit[1] Polarity : =1 Invert, =0 No Invert Bit[3:2] Alternate Function Select 11= KCLK (Default) 10=Either Edge Triggered Interrupt Input 1 (Note 26.20) 01= Reserved 00=Basic GPIO function Bits[6:4] Reserved Bit[7] Output Type Select 1=Open Drain (Default) 0=Push Pull APPLICATION NOTE: When Bits[3:2] are programmed to '11' to select the KCLK function, bit[0] should always be programmed to '0'. The KCLK function will not operate properly when bit[0] is set.

Table 26.3 Detailed Runtime Register Description (continued)

NAME	REG OFFSET (HEX)	DESCRIPTION
UART5 FIFO Control Shadow THIS REGISTER IS RESERVED FOR SCH3112 AND SCH3115 DEVICES	2E (R)	SCH3112 AND SCH3114 DEVICES Bits[7:0] RESERVED
UART5 FIFO Control Shadow SCH3116 DEVICE ONLY.	2E (R)	SCH3116 DEVICE UART FIFO Control Shadow 5 Bit[0] FIFO Enable Bit[1] RCVR FIFO Reset Bit[2] XMIT FIFO Reset Bit[3] DMA Mode Select Bit[5:4] Reserved Bit[6] RCVR Trigger (LSB) Bit[7] RCVR Trigger (MSB)
UART6 FIFO Control Shadow THIS REGISTER IS RESERVED FOR SCH3112 AND SCH3114 DEVICES	2F (R)	SCH3112 AND SCH3114 DEVICES Bits[7:0] RESERVED
UART6 FIFO Control Shadow SCH3116 DEVICE ONLY.	2F (R)	SCH3116 DEVICE UART FIFO Control Shadow 6 Bit[0] FIFO Enable Bit[1] RCVR FIFO Reset Bit[2] XMIT FIFO Reset Bit[3] DMA Mode Select Bit[5:4] Reserved Bit[6] RCVR Trigger (LSB) Bit[7] RCVR Trigger (MSB)
SP5 Option Default = 0x04 on VTR POR THIS REGISTER IS RESERVED FOR SCH3112 AND SCH3114 DEVICES	30 (R/W)	SCH3112 AND SCH3114 DEVICES Bits[7:0] RESERVED
SP5 Option Default = 0x04 on VTR POR SCH3116 DEVICE ONLY.	30 (R/W)	SCH3116 DEVICE - SP Options for SP5 Bit[0] nSCOUT5 Select: 1= nRTS5 0= nDTR5 Bit[2:1] nSCIN Select: 11= nDCD5 10= nRI5 01= nCTS5 00= nDSR5 Bit[3] Automatic Direction Control Select 1=FC on 0=FC off Bits[4] Signal select 1=nRTS control 0=nDTR control Bits[5] Polarity 0= Drive low when enabled 1= Drive 1 when enabled Bit[7:6] Reserved

Datasheet

Table 26.3 Detailed Runtime Register Description (continued)

NAME	REG OFFSET (HEX)	DESCRIPTION
SP6 Option Default = 0x04 on VTR POR THIS REGISTER IS RESERVED FOR SCH3112 AND SCH3114 DEVICES	31 (R/W)	SCH3112 AND SCH3114 DEVICES Bits[7:0] RESERVED
SP6 Option Default = 0x04 on VTR POR SCH3116 DEVICE ONLY.	31 (R/W)	SCH3116 DEVICE - SP Options for SP6 Bit[0] nSCOUT6 Select: 1= nRTS6 0= nDTR6 Bit[2:1] nSCIN Select: 11= nDCD6 10= nRI6 01= nCTS6 00= nDSR6 Bit[3] Automatic Direction Control Select 1=FC on 0=FC off Bits[4] Signal select 1=nRTS control 0=nDTR control Bits[5] Polarity 0= Drive low when enabled 1= Drive 1 when enabled Bit[7:6] Reserved
GP27 Default = 0x01 on VTR POR	32 (R/W)	General Purpose I/O bit 2.7 Bit[0] In/Out : =1 Input, =0 Output Bit[1] Polarity : =1 Invert, =0 No Invert Bit[3:2] Alternate Function Select 11=Reserved 10=8042 P17 function (Note 26.19) 01=nIO_SMI (Note 26.22) 00=GPIÖ Bits[6:4] Reserved Bit[7] Output Type Select 1=Open Drain 0=Push Pull
GP30 Default = 0x05 on VTR POR	33 (R/W)	General Purpose I/O bit 3.2 Bit[0] In/Out : =1 Input, =0 Output Bit[1] Polarity : =1 Invert, =0 No Invert Bit[2] Alternate Function Select 1=nFPRST (Default) 0=GPIÖ Bits[6:3] Reserved Bit[7] Output Type Select 1=Open Drain (Default) 0=Push Pull
GP31 Default = 0x01 on VTR POR SCH3112 DEVICE ONLY	34 (R/W)	General Purpose I/O bit 1.1 Bit[0] In/Out : =1 Input, =0 Output Bit[1] Polarity : =1 Invert, =0 No Invert Bits[6:2] Reserved Bit[7] Output Type Select read only returns 1= Open Drain Note: The pin can only be an Open Drain output.

Table 26.3 Detailed Runtime Register Description (continued)

NAME	REG OFFSET (HEX)	DESCRIPTION
GP31 Default = 0x01 on VTR POR SCH3114, SCH3116 DEVICES ONLY	34 (R/W)	General Purpose I/O bit 1.1 Bit[0] In/Out : =1 Input, =0 Output Bit[1] Polarity : =1 Invert, =0 No Invert Bit[2] Alternate Function Select 1= nRI4 0=GP31 Bits[6:3] Reserved Bit[7] Output Type Select read only returns 1= Open Drain Note: The pin can only be an Open Drain output.
GP32 Default = 0x84 on VTR POR	35 (R/W)	General Purpose I/O bit 3.2 Bit[0] In/Out : =1 Input, =0 Output Bit[1] Polarity : =1 Invert, =0 No Invert Bit[2] Alternate Function Select 1=MDAT (Default) 0=GPIO Bits[6:3] Reserved Bit[7] Output Type Select 1=Open Drain (Default) 0=Push Pull APPLICATION NOTE: When Bit[2] are programmed to '1' to select the MDAT function, bit[0] should always be programmed to '0'. The MDAT function will not operate properly when bit[0] is set.
GP33 Default = 0x84 on VTR POR	36 (R/W)	General Purpose I/O bit 3.3 Bit[0] In/Out : =1 Input, =0 Output Bit[1] Polarity : =1 Invert, =0 No Invert Bit[2] Alternate Function Select 1=MCLK (Default) 0=GPIO Bits[6:3] Reserved Bit[7] Output Type Select 1=Open Drain (Default) 0=Push Pull APPLICATION NOTE: When Bit[2] are programmed to '1' to select the MCLK function, bit[0] should always be programmed to '0'. The MCLK function will not operate properly when bit[0] is set.
GP34 Default = 0x01 on VTR POR SCH3112 DEVICE ONLY	37 (R/W)	General Purpose I/O bit 1.1 Bit[0] In/Out : =1 Input, =0 Output Bit[1] Polarity : =1 Invert, =0 No Invert Bits[6:2] Reserved Bit[7] Output Type Select read only returns 1= Open Drain Note: The pin can only be an Open Drain output.
GP34 Default = 0x01 on VTR POR SCH3114, SCH3116 DEVICES ONLY	37 (R/W)	General Purpose I/O bit 1.1 Bit[0] In/Out : =1 Input, =0 Output Bit[1] Polarity : =1 Invert, =0 No Invert Bit[2] Alternate Function Select 1= nDTR4 0=GP34 Bits[6:3] Reserved Bit[7] Output Type Select read only returns 1= Open Drain Note: The pin can only be an Open Drain output.

Table 26.3 Detailed Runtime Register Description (continued)

NAME	REG OFFSET (HEX)	DESCRIPTION
GP36 Default = 0x01 on VTR POR	39 (R/W)	General Purpose I/O bit 3.6 Bit[0] In/Out : =1 Input, =0 Output Bit[1] Polarity : =1 Invert, =0 No Invert Bit[2] Alternate Function Select 1= nKBDRST 0=Basic GPIO function Bits[6:3] Reserved Bit[7] Output Type Select 1=Open Drain 0=Push Pull
GP37 Default = 0x01 on VTR POR	3A (R/W)	General Purpose I/O bit 3.7 Bit[0] In/Out : =1 Input, =0 Output Bit[1] Polarity : =1 Invert, =0 No Invert Bit[2] Alternate Function Select 1=A20M 0=Basic GPIO function Bits[6:3] Reserved Bit[7] Output Type Select 1=Open Drain 0=Push Pull
GP40 Default =0x01 on VTR POR	3B (R/W)	General Purpose I/O bit 4.0 Bit[0] In/Out : =1 Input, =0 Output Bit[1] Polarity : =1 Invert, =0 No Invert Bit[2] Alternate Function Select 1=DRV DEN0 (Note 26.21) 0=Basic GPIO function Bits[6:3] Reserved Bit[7] Output Type Select 1=Open Drain 0=Push Pull
CLOCK Output Control Register VTR POR = 0x00	3C (R/W)	Bit[0] Enable 1= Output Enabled 0= Disable Clock output Bit[3:1] Frequency Select 000= 0.25 Hz 001= 0.50 Hz 010= 1.00 Hz 011= 2.00 Hz 100= 4.00 Hz 101= 8.00 Hz 110= 16 hz 111 = reserved Bit[7:4] Reserved
GP42 Default =0x01 on VTR POR	3D (R/W)	General Purpose I/O bit 4.2 Bit[0] In/Out : =1 Input, =0 Output Bit[1] Polarity : =1 Invert, =0 No Invert Bit[2] Alternate Function Select 1=nIQ_PME Note: configuring this pin function as output with non-inverted polarity will give an active low output signal. The output type can be either open drain or push-pull. 0=Basic GPIO function Bits[6:3] Reserved Bit[7] Output Type Select 1=Open Drain 0=Push Pull

Table 26.3 Detailed Runtime Register Description (continued)

NAME	REG OFFSET (HEX)	DESCRIPTION
GP50 Default = 0x01 on VTR POR	3F (R/W)	General Purpose I/O bit 5.0 Bit[0] In/Out : =1 Input, =0 Output Bit[1] Polarity : =1 Invert, =0 No Invert Bit[2] Alternate Function Select 1=nRI2 (Note 26.18) 0=GPIO Bits[6:3] Reserved Bit[7] Output Type Select 1=Open Drain 0=Push Pull
GP51 Default = 0x01 on VTR POR	40 (R/W)	General Purpose I/O bit 5.1 Bit[0] In/Out : =1 Input, =0 Output Bit[1] Polarity : =1 Invert, =0 No Invert Bit[2] Alternate Function Select 1=nDCD2 0=GPIO Bits[6:3] Reserved Bit[7] Output Type Select 1=Open Drain 0=Push Pull
GP52 Default = 0x01 on VTR POR	41 (R/W)	General Purpose I/O bit 5.2 Bit[0] In/Out : =1 Input, =0 Output Bit[1] Polarity : =1 Invert, =0 No Invert Bit[2] Alternate Function Select 1=RXD2 0=GPIO Bits[6:3] Reserved Bit[7] Output Type Select 1=Open Drain 0=Push Pull
GP53 Default = 0x01 on VTR POR	42 (R/W)	General Purpose I/O bit 5.3 Bit[0] In/Out : =1 Input, =0 Output Bit[1] Polarity : =1 Invert, =0 No Invert Bit[2] Alternate Function Select 1=TXD2 0=GPIO Bits[6:3] Reserved Bit[7] Output Type Select 1=Open Drain 0=Push Pull
GP54 Default = 0x01 on VTR POR	43 (R/W)	General Purpose I/O bit 5.4 Bit[0] In/Out : =1 Input, =0 Output Bit[1] Polarity : =1 Invert, =0 No Invert Bit[2] Alternate Function Select 1=nDSR2 0=GPIO Bit[3] RESERVED Bits[6:4] Reserved Bit[7] Output Type Select 1=Open Drain 0=Push Pull

Table 26.3 Detailed Runtime Register Description (continued)

NAME	REG OFFSET (HEX)	DESCRIPTION
GP55 Default = 0x01 on VTR POR	44 (R/W)	General Purpose I/O bit 5.5 Bit[0] In/Out : =1 Input, =0 Output Bit[1] Polarity : =1 Invert, =0 No Invert Bit[2] Alternate Function Select 1=nRTS2 0=GPIO Bit[3] RESERVED Bits[6:4] Reserved Bit[7] Output Type Select 1=Open Drain 0=Push Pull
GP56 Default = 0x01 on VTR POR	45 (R/W)	General Purpose I/O bit 5.6 Bit[0] In/Out : =1 Input, =0 Output Bit[1] Polarity : =1 Invert, =0 No Invert Bit[2] Alternate Function Select 1=nCTS2 0=GPIO Bit[3] RESERVED Bits[6:4] Reserved Bit[7] Output Type Select 1=Open Drain 0=Push Pull
GP57 Default = 0x01 on VTR POR	46 (R/W)	General Purpose I/O bit 5.7 Bit[0] In/Out : =1 Input, =0 Output Bit[1] Polarity : =1 Invert, =0 No Invert Bit[2] Alternate Function Select 1=nDTR2 0=GPIO Bit[3] RESERVED Bits[6:4] Reserved Bit[7] Output Type Select 1=Open Drain 0=Push Pull
GP60 Default = 0x01 on VTR POR	47 (R/W)	General Purpose I/O bit 6.0 Bit[0] In/Out : =1 Input, =0 Output Bit[1] Polarity : =1 Invert, =0 No Invert Bit[3:2] Alternate Function Select 11=WDT 10=Either Edge Triggered Interrupt Input 4 (Note 26.20) 01=LED1 00=GPIO Bits[6:4] Reserved Bit[7] Output Type Select 1=Open Drain 0=Push Pull
GP61 Default = 0x01 on VTR POR	48 (R/W)	General Purpose I/O bit 6.1 Bit[0] In/Out : =1 Input, =0 Output Bit[1] Polarity : =1 Invert, =0 No Invert Bit[3:2] Alternate Function Select 11=CLKO - Programmable clock output as described in 10=Either Edge Triggered Interrupt Input 5 (Note 26.20) 01=LED2 00=GPIO Bits[6:4] Reserved Bit[7] Output Type Select 1=Open Drain 0=Push Pull

Table 26.3 Detailed Runtime Register Description (continued)

NAME	REG OFFSET (HEX)	DESCRIPTION
<p>PWR_REC Power Recovery Register</p> <p>Default = 0xxxxx11b on VTR POR</p> <p>Default =x00000xxb on a Vbat POR</p> <p>Default = 0xxxxxxx on a VCC POR and PCI Reset</p> <p>Note: x indicates that the bit is not effected by this reset condition.</p> <p>SCH3112 AND SCH3114 DEVICES ONLY.</p>	<p>49</p> <p>R/W when bit[7] =0 (default), except for bit[4]</p> <p>Bit[4] is a Read-Only bit.</p> <p>Read-Only when bit[7]=1</p>	<p>SCH3112 AND SCH3114 DEVICES A/C Power Control/Recovery Register</p> <p>Bit[0] Power Button Enable 0=disabled 1=enabled (default)</p> <p>Bit[1] Keyboard Power Button Enable 0=disabled 1=enabled (default)</p> <p>Bit[2] Power Failure Recovery Enable 0=disabled (default) 1=enabled</p> <p>Bit[3] PS_ON# sampling enable 0=Sampling is disabled (Mode 1) 1=Sampling is enabled (Mode 2) When sampling is enabled the PS_ON# pin is sampled every 0.5 seconds and stored in an 8-bit shift register for up to a maximum of 4 seconds.</p> <p>Bit[4] Previous State Bit (This read-only bit is powered by Vbat) (NOTE: THIS BIT IS NOT RESET ON A VTR POR) This bit contains the state of the PS_ON# pin when VTR power is removed from the device. 0=off (PS_ON# signal was high) 1=on (PS_ON# signal was low)</p> <p>Bit[6:5] APF (After Power Failure) (These bits are powered by Vbat) (NOTE: THIS BIT IS NOT RESET ON A VTR POR) When VTR transitions from the OFF state to the ON state, the power recovery logic will look at the APF bits to determine if the power supply should be off or on. If the logic determines that the Power Supply should be place in the ON state it will generate a pulse on the PB_OUT# pin. The auto recovery logic does not directly control the PS_ON# pin. The PS_ON# pin is controlled by the SLP_Sx# pin. 00=Power Supply Off 01=Power Supply On 10=Power Supply set to Previous State 11=Power Supply Off</p> <p>Bit[7] Register Recovery R/W Control This bit is used to control write access to the Power Recovery Register at offset 49h. 0=Read/Write 1=Read-Only A/C Power Control/Recovery Register</p>

Datasheet

Table 26.3 Detailed Runtime Register Description (continued)

NAME	REG OFFSET (HEX)	DESCRIPTION
PWR_REC Power Recovery Register Default = 0xxxxx11b on VTR POR Default =x00000xxb on a Vbat POR Default = 0xxxxxxx on a VCC POR and PCI Reset Note: x indicates that the bit is not effected by this reset condition. THIS REGISTER IS RESERVED IN THE SCH3116 DEVICE	49 R/W when bit[7] =0 (default), except for bit[4] Bit[4] is a Read-Only bit. Read-Only when bit[7]=1	SCH3116 DEVICES Bits[7:0] RESERVED
PS_ON Register default = 0x00 on a Vbat POR default = value latched on Power Failure on a VTR POR SCH3112 AND SCH3114 DEVICES ONLY.	4A (R)	SCH3112 AND SCH3114 DEVICES PS_ON Shift Register This 8-bit register is used to read the PS_ON sample values loaded in the shift register in A/C Power Recovery Control - Mode 2. Bit[0] = PS_ON# sampled 0 - 0.5sec before power failure Bit[1] = PS_ON# sampled 0.5 - 1.0sec before power failure Bit[2] = PS_ON# sampled 1.0 - 1.5sec before power failure Bit[3] = PS_ON# sampled 1.5 - 2.0sec before power failure Bit[4] = PS_ON# sampled 2.0 - 2.5sec before power failure Bit[5] = PS_ON# sampled 2.5 - 3.0sec before power failure Bit[6] = PS_ON# sampled 3.0 - 3.5sec before power failure Bit[7] = PS_ON# sampled 3.5 - 4.0sec before power failure Bit definition 0=off (PS_ON# signal was high) 1=on (PS_ON# signal was low) Note: This register is powered by Vbat
PS_ON Register default = 0x00 on a Vbat POR default = value latched on Power Failure on a VTR POR THIS REGISTER IS RESERVED IN THE SCH3116 DEVICE	4A (R)	SCH3116 DEVICES Bits[7:0] RESERVED Note: This register is powered by Vbat

Table 26.3 Detailed Runtime Register Description (continued)

NAME	REG OFFSET (HEX)	DESCRIPTION
GP1 Default = 0x00 on VTR POR	4B (R/W)	General Purpose I/O Data Register 1 Bit[0] GP10 Bit[1] GP11 Bit[2] GP12 Bit[3] GP13 Bit[4] GP14 Bit[5] GP15 Bit[6] GP16 Bit[7] GP17
GP2 Default = 0x00 on VTR POR	4C (R/W)	General Purpose I/O Data Register 2 Bit[0] Reserved Bit[1] GP21 Bit[2] GP22 Bit[3] Reserved Bit[4] Reserved Bit[5] Reserved Bit[6] Reserved Bit[7] GP27
GP3 Default = 0x00 on VTR POR	4D (R/W)	General Purpose I/O Data Register 3 Bit[0] GP30 Bit[1] GP31 Bit[2] GP32 Bit[3] GP33 Bit[4] GP34 Bit[5] Reserved Bit[6] GP36 Bit[7] GP37
GP4 Default = 0x00 on VTR POR	4E (R/W)	General Purpose I/O Data Register 4 Bit[0] GP40 Bit[1] Reserved Bit[2] GP42 Bit[3] Reserved Bit[4] GP44 Bit[5] GP45 Bit[6] GP46 Bit[7] GP47
GP5 Default = 0x00 on VTR POR	4F (R/W)	General Purpose I/O Data Register 5 Bit[0] GP50 Bit[1] GP51 Bit[2] GP52 Bit[3] GP53 Bit[4] GP54 Bit[5] GP55 Bit[6] GP56 Bit[7] GP57
GP6 Default = 0x00 on VTR POR	50 (R/W)	General Purpose I/O Data Register 6 Bit[0] GP60 Bit[1] GP61 Bit[2] GP62 Bit[3] GP63 Bit[4] GP64 Bit[5] GP65 Bit[6] GP66 Bit[7] GP67
N/A	51 (R)	Bits[7:0] Reserved – reads return 0

Datasheet

Table 26.3 Detailed Runtime Register Description (continued)

NAME	REG OFFSET (HEX)	DESCRIPTION
PS_ON# Previous State Select Default = 0x00 on Vbat POR SCH3112 AND SCH3114 DEVICES ONLY.	53 (R/W)	SCH3112 AND SCH3114 DEVICES Bits[7:4] Reserved – reads return 0 Bit[3] SMSC Reserved, should be programmed to 0 for proper operation Bits[2:0] PS_ON# Previous State Select The TTL level of the PS_ON# pin is sampled every 0.5 seconds and placed into an 8-bit shift register while VTR and VCC are on. The PS_ON# Previous State Select bits determine which bit is used as the previous state bit following a power failure ($VTR \leq \sim 2.2V$). 000 = PS_ON# sampled 0 - 0.5sec before power failure 001 = PS_ON# sampled 0.5 - 1.0sec before power failure 010 = PS_ON# sampled 1.0 - 1.5sec before power failure 011 = PS_ON# sampled 1.5 - 2.0sec before power failure 100 = PS_ON# sampled 2.0 - 2.5sec before power failure 101 = PS_ON# sampled 2.5 - 3.0sec before power failure 110 = PS_ON# sampled 3.0 - 3.5sec before power failure 111 = PS_ON# sampled 3.5 - 4.0sec before power failure
PS_ON# Previous State Select Default = 0x00 on Vbat POR THIS REGISTER IS RESERVED IN THE SCH3116 DEVICE	53 (R/W)	SCH3116 DEVICE Bits[7:0] RESERVED
GP62 Default = 0x01 on VTR POR SCH3112 DEVICE ONLY	54 (R/W)	General Purpose I/O bit 5.7 Bit[0] In/Out : =1 Input, =0 Output Bit[1] Polarity : =1 Invert, =0 No Invert Bits[6:2] Reserved Bit[7] Output Type Select 1=Open Drain 0=Push Pull
GP62 Default = 0x01 on VTR POR SCH3114, SCH3116 DEVICES ONLY	54 (R/W)	General Purpose I/O bit 5.7 Bit[0] In/Out : =1 Input, =0 Output Bit[1] Polarity : =1 Invert, =0 No Invert Bit[2] Alternate Function Select 1=nCTS4 0=GPIO Bits[6:3] Reserved Bit[7] Output Type Select 1=Open Drain 0=Push Pull
GP63 Default = 0x01 on VTR POR SCH3112 DEVICE ONLY	55 (R/W)	General Purpose I/O bit 5.7 Bit[0] In/Out : =1 Input, =0 Output Bit[1] Polarity : =1 Invert, =0 No Invert Bits[6:2] Reserved Bit[7] Output Type Select 1=Open Drain 0=Push Pull

Table 26.3 Detailed Runtime Register Description (continued)

NAME	REG OFFSET (HEX)	DESCRIPTION
GP63 Default = 0x01 on VTR POR SCH3114, SCH3116 DEVICES ONLY	55 (R/W)	General Purpose I/O bit 5.7 Bit[0] In/Out : =1 Input, =0 Output Bit[1] Polarity : =1 Invert, =0 No Invert Bit[2] Alternate Function Select 1=nDCD4 0=GPIO Bits[6:3] Reserved Bit[7] Output Type Select 1=Open Drain 0=Push Pull
GP64 Default = 0x01 on VTR POR SCH3112 DEVICE ONLY	56 (R/W)	General Purpose I/O bit 5.7 Bit[0] In/Out : =1 Input, =0 Output Bit[1] Polarity : =1 Invert, =0 No Invert Bits[6:2] Reserved Bit[7] Output Type Select 1=Open Drain 0=Push Pull
GP64 Default = 0x01 on VTR POR SCH3114, SCH3116 DEVICES ONLY	56 (R/W)	General Purpose I/O bit 5.7 Bit[0] In/Out : =1 Input, =0 Output Bit[1] Polarity : =1 Invert, =0 No Invert Bit[2] Alternate Function Select 1=RXD4 0=GPIO Bits[6:3] Reserved Bit[7] Output Type Select 1=Open Drain 0=Push Pull
GP65 Default = 0x01 on VTR POR SCH3112 DEVICE ONLY	57 (R/W)	General Purpose I/O bit 5.7 Bit[0] In/Out : =1 Input, =0 Output Bit[1] Polarity : =1 Invert, =0 No Invert Bits[6:2] Reserved Bit[7] Output Type Select 1=Open Drain 0=Push Pull
GP65 Default = 0x01 on VTR POR SCH3114, SCH3116 DEVICES ONLY	57 (R/W)	General Purpose I/O bit 5.7 Bit[0] In/Out : =1 Input, =0 Output Bit[1] Polarity : =1 Invert, =0 No Invert Bit[2] Alternate Function Select 1=TXD4 0=GPIO Bits[6:3] Reserved Bit[7] Output Type Select 1=Open Drain 0=Push Pull
GP66 Default = 0x01 on VTR POR SCH3112 DEVICE ONLY	58 (R/W)	General Purpose I/O bit 5.7 Bit[0] In/Out : =1 Input, =0 Output Bit[1] Polarity : =1 Invert, =0 No Invert Bits[6:2] Reserved Bit[7] Output Type Select 1=Open Drain 0=Push Pull

Datasheet

Table 26.3 Detailed Runtime Register Description (continued)

NAME	REG OFFSET (HEX)	DESCRIPTION
GP66 Default = 0x01 on VTR POR SCH3114, SCH3116 DEVICES ONLY	58 (R/W)	General Purpose I/O bit 5.7 Bit[0] In/Out : =1 Input, =0 Output Bit[1] Polarity : =1 Invert, =0 No Invert Bit[2] Alternate Function Select 1=nDSR4 0=GPIO Bits[6:3] Reserved Bit[7] Output Type Select 1=Open Drain 0=Push Pull
GP67 Default = 0x01 on VTR POR SCH3112 DEVICE ONLY	59 (R/W)	General Purpose I/O bit 5.7 Bit[0] In/Out : =1 Input, =0 Output Bit[1] Polarity : =1 Invert, =0 No Invert Bits[6:2] Reserved Bit[7] Output Type Select 1=Open Drain 0=Push Pull
GP67 Default = 0x01 on VTR POR SCH3114, SCH3116 DEVICES ONLY	59 (R/W)	General Purpose I/O bit 5.7 Bit[0] In/Out : =1 Input, =0 Output Bit[1] Polarity : =1 Invert, =0 No Invert Bit[2] Alternate Function Select 1=nRTS4 0=GPIO Bits[6:3] Reserved Bit[7] Output Type Select 1=Open Drain 0=Push Pull
TEST Default = 0x00 on VBAT POR	5A (R)	Bits[0:1,5] SMSC Reserved bit. Must be written as a '0'. Bits[2:4,6:7] Reserved Read only.
DBLCLICK Default = 0x0C on VBAT POR	5B Bits [5:0] are R/W when Mouse_Specific_Wake register- Bit [7] is '0' Bits [5:0] are Read Only when Mouse_Specific_Wake register- Bit [7] is '1'	Double Click for Specific Wake on Mouse Select Register The DBLCLICK contains a numeric value that determines the time interval used to check for a double mouse click. DBLCLICK is the time interval between mouse clicks. For example, if DBLCLICK is set to 0.5 seconds, you have one half second to click twice for a double-click. Bit[0:5] This field contains a six bit weighted sum value from 0 to 0x3Fh which provides a double click interval between 0.0859375 and 5.5 seconds. Each incremental digit has a weight of 0.0859375 seconds. Bit[6] Reserved - returns zero when read Bit[7] Spinup delay 1= zero delay for spinup following VTR POR 0 = spinup delay by 2 seconds (default)

Table 26.3 Detailed Runtime Register Description (continued)

NAME	REG OFFSET (HEX)	DESCRIPTION
<p>Mouse_Specific_Wake</p> <p>Default = 00h on VBAT POR</p> <p>Default = 0xxxxxxx on VTR POR, VCC POR, and PCI Reset</p> <p>Note: The 'x' indicates bit is not effected by reset</p>	<p>5C</p> <p>R/W when Bit [7] is '0'</p> <p>Read Only when Bit [7] is '1'</p>	<p>Specific Wake on Mouse Click Control Register Bit[0:1] SMSC Reserved bit. Must be written as a '0'.</p> <p>Bits[4:2] SPESME SELECT. These bits select which mouse event is/are routed to trigger a PME wake event. 000 = Any button click or any movement (left/right/middle) 001 = One click of left button. 010 = One click of right button. 011 = Any one click of left/right/middle button. 100 = Reserved 101 = Two times click of left button. 110 = Two times click of right button. 111 = Reserved</p> <p>Bit[5] Reserved. Read only zero.</p> <p>Bit[6] KB_MSE_SWAP. This bit swaps the Keyboard and Mouse Port interfaces. 0 = The Keyboard and Mouse Ports are not swapped. 1 = The Keyboard and Mouse Ports are swapped.</p> <p>Bit [7] Mouse_Specific_Wake Lock (Note) (This bit is Reset on a VBAT POR, VTR POR, VCC POR, and PCI Reset) 0 = Mouse_Specific_Wake, and DBLCLICK Registers are Read/Write. 1 = Mouse_Specific_Wake and DBLCLICK Registers are Read Only.</p>
<p>LED1</p> <p>Default = 0x00 on VTR POR</p>	<p>5D</p> <p>(R/W)</p>	<p>LED1 Bit[1:0] LED1 Control 00=off 01=blink at 1Hz rate with a 50% duty cycle (0.5 sec on, 0.5 sec off) 10=Blink at ½ HZ rate with a 25% duty cycle (0.5 sec on, 1.5 sec off) 11=on Bits[7:2] Reserved</p>
<p>LED2</p> <p>Default = 0x00 on VTR POR</p>	<p>5E</p> <p>(R/W)</p>	<p>LED2 Bit[1:0] LED2 Control 00=off 01=blink at 1Hz rate with a 50% duty cycle (0.5 sec on, 0.5 sec off) 10=Blink at ½ HZ rate with a 25% duty cycle (0.5 sec on, 1.5 sec off) 11=on Bits[7:2] Reserved</p>
<p>Keyboard Scan Code – Make Byte 1 (MSB)</p> <p>Default = 0xE0 on Vbat POR</p>	<p>5F</p> <p>(R/W)</p>	<p>Keyboard Scan Code This register is used to decode the first byte received from keyboards that generate multi-byte make codes and for single byte make codes.</p> <p>Bit[0] LSB of Scan Code Bit[7] MSB of Scan Code</p> <p>Note: The keyboard scan code registers default to the ACPI scan 2 Power make/break codes. (i.e., make=E0_37, break=E0_F0_37). Note: Programming this register to 0x00 indicates that this register a don't care. Any valid scan code that is received will be a match.</p>

Table 26.3 Detailed Runtime Register Description (continued)

NAME	REG OFFSET (HEX)	DESCRIPTION
Keyboard Scan Code – Make Byte 2 (LSB) Default = 0x37 on Vbat POR	60 (R/W)	Keyboard Scan Code This register is used only for multi-byte make codes. It is used to decode the second byte received. Bit[0] LSB of Scan Code Bit[7] MSB of Scan Code Note: The keyboard scan code registers default to the ACPI scan 2 Power make/break codes. (i.e., make=E0_37, break=E0_F0_37). Note: Programming this register to 0x00 indicates that this register a don't care. Any valid scan code that is received will be a match.
Keyboard Scan Code – Break Byte 1 (MSB) Default = 0xE0 on Vbat POR	61 (R/W)	Keyboard Scan Code This register is used to decode the first byte received from keyboards that generate multi-byte make codes and for single byte break codes. Bit[0] LSB of Scan Code Bit[7] MSB of Scan Code Note: The keyboard scan code registers default to the ACPI scan 2 Power make/break codes. (i.e., make=E0_37, break=E0_F0_37). Note: Programming this register to 0x00 indicates that this register a don't care. Any valid scan code that is received will be a match.
Keyboard Scan Code – Break Byte 2 Default = 0xF0 on Vbat POR	62 (R/W)	Keyboard Scan Code This register is used to decode the second byte received in multi-byte break codes. Bit[0] LSB of Scan Code Bit[7] MSB of Scan Code Note: The keyboard scan code registers default to the ACPI scan 2 Power make/break codes. (i.e., make=E0_37, break=E0_F0_37). Note: Programming this register to 0x00 indicates that this register a don't care. Any valid scan code that is received will be a match.
Keyboard Scan Code – Break Byte 3 (LSB) Default = 0x37 on Vbat POR	63 (R/W)	Keyboard Scan Code This register is used to decode the third byte received in scan 2 multi-byte break codes. Bit[0] LSB of Scan Code Bit[7] MSB of Scan Code Note: The keyboard scan code registers default to the ACPI scan 2 Power make/break codes. (i.e., make=E0_37, break=E0_F0_37). Note: Programming this register to 0x00 indicates that this register a don't care. Any valid scan code that is received will be a match.

Table 26.3 Detailed Runtime Register Description (continued)

NAME	REG OFFSET (HEX)	DESCRIPTION
Keyboard PWRBTN/SPEKEY Default = 6Ch on Vbat POR Default = 0xxxxxxb on VTR POR, VCC POR, and PCI Reset Note: The 'x' indicates bit is not effected by reset	64 R/W when Bit [7] is '0' Read Only when Bit [7] is '1'	Bit[0] SMSC Reserved bit. Must be written as a '0'. Bit[1] SMSC Reserved bit. Must be written as a '0'. Bits[3:2] SPEKEY ScanCode. This bit is used to configure the hardware to decode a particular type of scan code. 00 = Single Byte, Scan Code Set 1 (Ex. make=37h and break=B7h) 01 =Multi-Byte, Scan Code Set 1 (Ex. make = E0h, 37h and break = E0h, B7h) 10 = Single Byte, Scan Code Set 2 (Ex. make=37h and break=F0h 37h) 11 = Multi-Byte, Scan Code Set 2 (Ex. make = E0h, 37h and break = E0h F0h 37h) (Default) Bits[5:4] Keyboard Power Button Release These bits are used to determine the pulse width of the Power Button event from the keyboard (KB_PB_STS). The wake on specific key can be configured to generate a PME event and/or power button event. If it is used to generate a power button event, the following bits will determine when the KB_PB_STS event is de-asserted. 00=De-assert KB_PB_STS 0.5sec after it is asserted (default) 01=De-assert KB_PB_STS after any valid scan code NOT EQUAL to the programmed make code. 10=De-assert KB_PB_STS when scan code received is equal to programmed break code 11=Reserved Bit[6] SMSC Reserved bit. Must be written as a '1'.
Keyboard PWRBTN/SPEKEY (continued)		Bit [7] Keyboard PWRBTN/SPEKEY Lock (Note) (This bit is Reset on a Vbat POR, VTR POR, VCC POR, and PCI Reset) 0 = Keyboard PWRBTN/SPEKEY and Keyboard Scan Code Registers are Read/Write 1 = Keyboard PWRBTN/SPEKEY and Keyboard Scan Code Registers are Read Only Note: The following registers become Read-Only when Bit [7] is '1': Keyboard Scan Code – Make Byte 1 at offset 5Fh Keyboard Scan Code – Make Byte 2 at offset 60h Keyboard Scan Code – Break Byte 1 at offset 61h Keyboard Scan Code – Break Byte 2 at offset 62h Keyboard Scan Code – Break Byte 3 at offset 63h Keyboard PWRBTN/SPEKEY at offset 64h
WDT_TIME_OUT Default = 0x00 on VCC POR, VTR POR, and PCI Reset	65 (R/W)	Watch-dog Timeout Bit[0] Reserved Bit[1] Reserved Bits[6:2] Reserved, = 00000 Bit[7] WDT Time-out Value Units Select = 0 Minutes (default) = 1 Seconds
WDT_VAL Default = 0x00 on VCC POR, VTR POR, and PCI Reset	66 (R/W)	Watch-dog Timer Time-out Value Binary coded, units = minutes (default) or seconds, selectable via Bit[7] of WDT_TIME_OUT register (0x52). 0x00 Time out disabled 0x01 Time-out = 1 minute (second) 0xFF Time-out = 255 minutes (seconds)

Datasheet

Table 26.3 Detailed Runtime Register Description (continued)

NAME	REG OFFSET (HEX)	DESCRIPTION
WDT_CFG Default = 0x00 on VCC POR, VTR POR, and PCI Reset	67 (R/W)	Watch-dog timer Configuration Bit[0] Reserved Bit[1] Keyboard Enable =1 WDT is reset upon a Keyboard interrupt. =0 WDT is not affected by Keyboard interrupts. Bit[2] Mouse Enable =1 WDT is reset upon a Mouse interrupt. =0 WDT is not affected by Mouse interrupts. Bit[3] Reserved Bits[7:4] WDT Interrupt Mapping 1111 = IRQ15 0011 = IRQ3 0010 = IRQ2 (Note) 0001 = IRQ1 0000 = Disable Note: IRQ2 is used for generating SMI events via the serial IRQ's stream. The WDT should not be configured for IRQ2 if the IRQ2 slot is enabled for generating an SMI event.
WDT_CTRL Default = 0x00 on VCC POR and VTR POR Default = 0000000xb on PCI Reset Note: Bit[0] is not cleared by PCI Reset	68 (R/W) Bit[2] is Write-Only	Watch-dog timer Control Bit[0] Watch-dog Status Bit, R/W =1 WD timeout occurred =0 WD timer counting Bit[1] Reserved Bit[2] Force Timeout, W =1 Forces WD timeout event; this bit is self-clearing Bit[3] P20 Force Timeout Enable, R/W = 1 Allows rising edge of P20, from the Keyboard Controller, to force the WD timeout event. A WD timeout event may still be forced by setting the Force Timeout Bit, bit 2. Note: If the P20 signal is high when the enable bit is set a WD timeout event will be generated. = 0 P20 activity does not generate the WD timeout event. Note: The P20 signal will remain high for a minimum of 1us and can remain high indefinitely. Therefore, when P20 forced timeouts are enabled, a self- clearing edge-detect circuit is used to generate a signal which is OR'ed with the signal generated by the Force Timeout Bit. Bit[7:4] Reserved. Set to 0
TEST Default=0x00 on Vbat POR	6D (R/W)	Test Register. Test Registers are reserved for SMSC. Users should not write to this register, may produce undesired results.
GP44 Default = 0x80 on VTR POR SCH3112, SCH3114 ONLY	6Eh (R/W)	General Purpose I/O bit 4.4 Bit[0] In/Out : =1 Input, =0 Output Bit[1] Polarity : =1 Invert, =0 No Invert Bit[2] Alternate Function Select 1=GPIO 0=nIDE_RSTDRV (Default) Bits[6:3] Reserved Bit[7] Output Type Select 1=Open Drain 0=Push Pull

Table 26.3 Detailed Runtime Register Description (continued)

NAME	REG OFFSET (HEX)	DESCRIPTION
GP44 Default = 0x01 on VTR POR SCH3116 ONLY	6Eh (R/W)	General Purpose I/O bit 4.4 Bit[0] In/Out : =1 Input, =0 Output Bit[1] Polarity : =1 Invert, =0 No Invert Bit[2] Alternate Function Select 1=TXD6 0=GPIO (Default) Bits[6:3] Reserved Bit[7] Output Type Select 1=Open Drain 0=Push Pull
GP45 Default = 0x00 on VTR POR SCH3112, SCH3114 ONLY	6Fh (R/W)	General Purpose I/O bit 4.4 Bit[0] In/Out : =1 Input, =0 Output Bit[1] Polarity : =1 Invert, =0 No Invert Bit[2] Alternate Function Select 1=GPIO 0=nPCI_RST1 (Default) Bits[6:3] Reserved Bit[7] Output Type Select 1=Open Drain 0=Push Pull
GP45 Default = 0x01 on VTR POR SCH3116 ONLY	6Fh (R/W)	General Purpose I/O bit 4.4 Bit[0] In/Out : =1 Input, =0 Output Bit[1] Polarity : =1 Invert, =0 No Invert Bit[2] Alternate Function Select 1=RXD6 0=GPIO (Default) Bits[6:3] Reserved Bit[7] Output Type Select 1=Open Drain 0=Push Pull
HW_Reg INDEX Default=0x00 on VTR POR	70 (R/W)	The register is used to access the registers located in the H/W Monitoring Register block. The value in this register is the register INDEX (address), which determines the register currently accessible.
HW_Reg DATA Default=0x00 on VTR POR	71 (R/W)	This register is used to Read/Write the data in the hardware monitoring register that is currently INDEX'd. (See the HW_Reg INDEX register at offset 60h.)
GP46 Default = 0x00 on VTR POR SCH3112, SCH3114 ONLY	72h (R/W)	General Purpose I/O bit 4.4 Bit[0] In/Out : =1 Input, =0 Output Bit[1] Polarity : =1 Invert, =0 No Invert Bit[2] Alternate Function Select 1=GPIO 0=nPCI_RST2 (Default) Bits[6:3] Reserved Bit[7] Output Type Select 1=Open Drain 0=Push Pull
GP46 Default = 0x01 on VTR POR SCH3116 ONLY	72h (R/W)	General Purpose I/O bit 4.4 Bit[0] In/Out : =1 Input, =0 Output Bit[1] Polarity : =1 Invert, =0 No Invert Bit[2] Alternate Function Select 1=nSCIN6 0=GPIO (Default) Bits[6:3] Reserved Bit[7] Output Type Select 1=Open Drain 0=Push Pull

Table 26.3 Detailed Runtime Register Description (continued)

NAME	REG OFFSET (HEX)	DESCRIPTION
GP47 Default = 0x00 on VTR POR SCH3112, SCH3114 ONLY	73h (R/W)	General Purpose I/O bit 4.4 Bit[0] In/Out : =1 Input, =0 Output Bit[1] Polarity : =1 Invert, =0 No Invert Bit[2] Alternate Function Select 1=GPIO 0=nPCI_RST3 (Default) Bits[6:3] Reserved Bit[7] Output Type Select 1=Open Drain 0=Push Pull
GP47 Default = 0x01 on VTR POR SCH3116 ONLY	73h (R/W)	General Purpose I/O bit 4.4 Bit[0] In/Out : =1 Input, =0 Output Bit[1] Polarity : =1 Invert, =0 No Invert Bit[2] Alternate Function Select 1=nSCOUT6 0=GPIO (Default) Bits[6:3] Reserved Bit[7] Output Type Select 1=Open Drain 0=Push Pull
N/A	74-7F (R)	Bits[7:0] Reserved – reads return 0

Note: When selecting an alternate function for a GPIO pin, all bits in the GPIO register must be properly programmed, including in/out, polarity and output type.

APPLICATION NOTE:

- Note 26.18** If this pin is used for Ring Indicator wakeup, either the nRI2 event can be enabled via bit 1 in the PME_EN1 register or the GP50 PME event can be enabled via bit 0 in the PME_EN5 register.
- Note 26.19** In order to use the P17 functions, the corresponding GPIO must be programmed for output, non-invert, and push-pull output type.
- Note 26.20** If the EETI function is selected for this GPIO then both a high-to-low and a low-to-high edge will set the PME, SMI and MSC status bits.
- Note 26.21** If the FDC function is selected on this pin (DRVDEN0) then bit 6 of the FDD Mode Register (Configuration Register 0xF0 in Logical Device 0) will override bit 7 in the GPIO Control Register. Bit 7 of the FDD Mode Register will also affect the pin if the FDC function is selected.
- Note 26.22** The nIO_SMI pin is inactive when the internal group SMI signal is inactive and when the SMI enable bit (EN_SMI, bit 7 of the SMI_EN2 register) is '0'. When the output buffer type is OD, nIO_SMI pin is floating when inactive; when the output buffer type is push-pull, the nIO_SMI pin is high when inactive.
- Note 26.23** Bit3 of the PME_STS5 register may be set on a VCC POR. If GP53 is configured as input, then the corresponding PME status bits will be set on a VCC POR. These bits are R/W but have no effect on circuit operation.
- Note 26.24** These bits are R/W but have no effect on circuit operation.



Chapter 27 Valid Power Modes

The following table shows the valid power states for each power supply to the device.

Table 27.1 Valid Power States

POWER SUPPLY	POWER STATE		
	S0-S2	S3	S4-S5
Vbat	On Off (Note 27.1)	On Off (Note 27.1)	On Off (Note 27.1)
VTR	On	On	On
VCC	On	Off	Off
HVTR	On (HVTR=VTR)	On (HVTR=VTR)	On (HVTR=VTR)

Note 27.1 Although this is not considered normal operating mode, Vbat = Off is a valid power state. When Vbat is off all battery backed system context will be lost.



Chapter 28 Operational Description

28.1 Maximum Guaranteed Ratings

Operating Temperature Range -40°C to +85°C

Storage Temperature Range -55° to +150°C

Lead Temperature Range Refer to JEDEC Spec. J-STD-020b

Note: Stresses above those listed above and below could cause permanent damage to the device. This is a stress rating only and functional operation of the device at any other condition above those indicated in the operation sections of this specification is not implied. When powering this device from laboratory or system power supplies, it is important that the Absolute Maximum Ratings not be exceeded or device failure can result. Some power supplies exhibit voltage spikes on their outputs when the AC power is switched on or off. In addition, voltage transients on the AC power line may appear on the DC output. If this possibility exists, it is suggested that a clamp circuit be used.

28.1.1 Super I/O section (pins 3 to 112)

Maximum V_{CC} +5.5V

Positive Voltage on any pin, with respect to Ground $V_{CC}+0.3V$

Negative Voltage on any pin, with respect to Ground -0.3V

28.1.2 Hardware Monitoring Block (pins 1 and 2 and pins 113 to 128)

Maximum HVTR +5.5V

Positive Voltage on any pin, with respect to Ground (Except analog inputs) HVTR+0.3V

Negative Voltage on any pin, with respect to Ground (Except analog inputs) -0.3V

28.2 DC Electrical Characteristics

Table 28.1 Buffer Operational Ratings

SUPER I/O BLOCK ($T_A = -40^{\circ}C - +85^{\circ}C$, $V_{CC} = +3.3 V \pm 10\%$)						
PARAMETER	SYMBOL	MIN	TYP	MAX	UNITS	COMMENTS
I Type Input Buffer						
Low Input Level	V_{ILI}			0.8	V	TTL Levels
High Input Level	V_{IHI}	2.0		5.5	V	
IS Type Input Buffer						
Low Input Level	V_{ILIS}			0.8	V	Schmitt Trigger
High Input Level	V_{IHIS}	2.2		5.5	V	Schmitt Trigger
Schmitt Trigger Hysteresis	V_{HYS}		100		mV	

Table 28.1 Buffer Operational Ratings (continued)

SUPER I/O BLOCK ($T_A = -40^{\circ}\text{C} - +85^{\circ}\text{C}$, $V_{CC} = +3.3\text{ V} \pm 10\%$)						
PARAMETER	SYMBOL	MIN	TYP	MAX	UNITS	COMMENTS
O6 Type Buffer						
Low Output Level	V_{OL}			0.4	V	$I_{OL} = 6\text{mA}$
High Output Level	V_{OH}	2.4			V	$I_{OH} = -3\text{mA}$
O8 Type Buffer						
Low Output Level	V_{OL}			0.4	V	$I_{OL} = 8\text{mA}$
High Output Level	V_{OH}	2.4			V	$I_{OH} = -4\text{mA}$
OD4 Type Buffer						
Low Output Level	V_{OL}			0.4	V	$I_{OL} = 4\text{mA}$
High Output Level	V_{OH}			$V_{CC}+0.3$	V	Open Drain; $V_{CC}=3.3\text{V}$
OD8 Type Buffer						
Low Output Level	V_{OL}			0.4	V	$I_{OL} = 8\text{mA}$
High Output Level	V_{OH}			$V_{CC}+0.3$	V	Open Drain; $V_{CC}=3.3\text{V}$
O12 Type Buffer						
Low Output Level	V_{OL}			0.4	V	$I_{OL} = 12\text{mA}$
High Output Level	V_{OH}	2.4			V	$I_{OH} = -6\text{mA}$
OD12 Type Buffer						
Low Output Level	V_{OL}			0.4	V	$I_{OL} = 12\text{mA}$
High Output Level	V_{OH}			$V_{CC}+0.3$	V	Open Drain; $V_{CC}=3.3\text{V}$
OD14 Type Buffer						
Low Output Level	V_{OL}			0.4	V	$I_{OL} = 14\text{mA}$
High Output Level	V_{OH}			$V_{CC}+0.3$	V	Open Drain; $V_{CC}=3.3\text{V}$
OP14 Type Buffer						
Low Output Level	V_{OL}			0.4	V	$I_{OL} = 14\text{mA}$
High Output Level	V_{OH}	2.4			V	$I_{OH} = -14\text{mA}$
IO8 Type Buffer						
Low Input Level	V_{ILI}			0.8	V	TTL Levels
High Input Level	V_{IHI}	2.0		5.5	V	
Low Output Level	V_{OL}			0.4	V	$I_{OL} = 8\text{mA}$
High Output Level	V_{OH}	2.4			V	$I_{OH} = -4\text{mA}$

Table 28.1 Buffer Operational Ratings (continued)

SUPER I/O BLOCK ($T_A = -40^{\circ}\text{C} - +85^{\circ}\text{C}$, $V_{CC} = +3.3\text{ V} \pm 10\%$)						
PARAMETER	SYMBOL	MIN	TYP	MAX	UNITS	COMMENTS
IS/O8 Type Buffer						
Low Input Level	V_{ILI}			0.8	V	Schmitt Trigger
High Input Level	V_{IHI}	2.2		5.5	V	Schmitt Trigger
Schmitt Trigger Hysteresis	V_{HYS}		100		mV	
Low Output Level	V_{OL}			0.4	V	$I_{OL} = 8\text{mA}$
High Output Level	V_{OH}	2.4			V	$I_{OH} = -4\text{mA}$
IO12 Type Buffer						
Low Input Level	V_{ILI}			0.8	V	TTL Levels
High Input Level	V_{IHI}	2.0		5.5	V	
Low Output Level	V_{OL}			0.4	V	$I_{OL} = 12\text{mA}$
High Output Level	V_{OH}	2.4			V	$I_{OH} = -6\text{mA}$
IOP14 Type Buffer						
Low Input Level	V_{ILI}			0.8	V	TTL Levels
High Input Level	V_{IHI}	2.0		5.5	V	
Low Output Level	V_{OL}			0.4	V	$I_{OL} = 14\text{mA}$
High Output Level	V_{OH}	2.4			V	$I_{OH} = -14\text{mA}$
IOD16 Type Buffer						
Low Input Level	V_{ILI}			0.8	V	TTL Levels
High Input Level	V_{IHI}	2.0		5.5	V	
Low Output Level	V_{OL}			0.4	V	$I_{OL} = 16\text{mA}$
High Output Level	V_{OH}			$V_{CC}+0.3$	V	Open Drain; $V_{CC}=3.3\text{V}$
OD_PH Type Buffer						
	VOL				0.3	V RLOAD is 40ohms to 1.2V Max Output impedance is 10ohms
PCI Type Buffers (PCI_ICLK, PCI_I, PCI_O, PCI_IO)						
3.3V PCI 2.1 Compatible.						
Leakage Current (ALL)						
Input High Current	$I_{LEAK_{IH}}$			10	μA	(Note 28.1) $V_{IN} = V_{CC}$
Input Low Current	$I_{LEAK_{IL}}$			-10	μA	$V_{IN} = 0\text{V}$

Table 28.1 Buffer Operational Ratings (continued)

SUPER I/O BLOCK ($T_A = -40^{\circ}\text{C} - +85^{\circ}\text{C}$, $V_{CC} = +3.3\text{ V} \pm 10\%$)						
PARAMETER	SYMBOL	MIN	TYP	MAX	UNITS	COMMENTS
Backdrive Protect/ChiProtect (All signal pins excluding LAD[3:0], LDRQ#, LFRAME#) Input High Current Input Low Current	 ILEAK _{IH} ILEAK _{IL}			 10 -10	 μA μA	$V_{CC} = 0\text{V}$ $V_{IN} = 5.5\text{V Max}$ $V_{IN} = 0\text{V}$
5V Tolerant Pins (All signal pins excluding LAD[3:0], LDRQ#, LFRAME#) Inputs and Outputs in High Impedance State Input High Current Input Low Current	 ILEAK _{IH} ILEAK _{IL}			 10 -10	 μA μA	$V_{CC} = 0\text{V}$ $V_{IN} = 5.5\text{V Max}$ $V_{IN} = 0\text{V}$
LPC Bus Pins (LAD[3:0], LDRQ#, LFRAME#) Input High Current Input Low Current	 ILEAK _{IH} ILEAK _{IL}			 10 -10	 μA μA	$V_{CC} = 0\text{V}$ and $V_{CC} = 3.3\text{V}$ $V_{IN} = 3.6\text{V Max}$ $V_{IN} = 0\text{V}$
V_{CC} Supply Current Active	I _{CC}			15 (Note 28.2)	mA	All outputs open, all inputs transitioning from/to 0V to/from 3.3V.
Trickle Supply Voltage	V _{TR}	2.97 (Note 28.3)	3.3	3.63	V	
V_{TR} Supply Current Active	I _{TR}	0.25 (Note 28.2, Note 28.4)		10 (Note 28.2, Note 28.4)	mA	All outputs, all inputs transitioning from/to 0V to/from 3.3V.
Battery Supply Voltage	V _{BAT}	2.2	3.0	3.6	V	
V_{BAT} Average Supply Current Active V_{BAT} Monitoring Active V_{BAT} Monitoring Disabled	 I _{BAT, AVG} I _{BAT, AVG}			 1.5 1.0	 μA μA	All outputs open, all inputs transitioning to/from 0V from/to 3.0V). See PME_STS1.
V_{BAT} Peak Supply Current Active V_{BAT} Monitoring Active	I _{BAT, Peak}			10	μA	All outputs open, all inputs transitioning to/from 0V from/to 3.0V). See PME_STS1.

Datasheet

HARDWARE MONITORING BLOCK ($T_A = -40^{\circ}\text{C} - +85^{\circ}\text{C}$, HVTR = +3.3 V \pm 10%)						
Parameter	Symbol	Min	Typ	Max	Units	Comments
Temperature-to-Digital Converter Characteristics						
Internal Temperature Accuracy		-3 -2	± 0.25	+3 +2	$^{\circ}\text{C}$ $^{\circ}\text{C}$	$0^{\circ}\text{C} \leq T_A \leq 70^{\circ}\text{C}$ $40^{\circ}\text{C} \leq T_A \leq 70^{\circ}\text{C}$ Resolution
External Diode Sensor Accuracy		-5 -3	± 0.25	+5 +3	$^{\circ}\text{C}$ $^{\circ}\text{C}$	$-40^{\circ}\text{C} \leq T_S \leq 125^{\circ}\text{C}$ $40^{\circ}\text{C} \leq T_S \leq 100^{\circ}\text{C}$ Resolution
Analog-to-Digital Converter Characteristics						
Total Unadjusted Error	TUE			± 2	%	Note 28.5
Differential Non-Linearity	DNL		± 1		LSB	
Power Supply Sensitivity	PSS		± 1		%/V	
Total Monitoring Cycle Time (Cycle Mode, Default Averaging)	$t_{C(\text{Cycle})}$		1.25	1.4	sec	Note 28.6
Conversion Time (Continuous Mode, Default Averaging)	$t_{C(\text{Cts})}$	225	247	275	msec	Note 28.7
Input Resistance			140	200	$\text{k}\Omega$	
ADC Resolution						10 bits Note 28.10
Input Buffer (I) (FANTACH1-FANTACH4)						
Low Input Level	V_{ILI}			0.8	V	
High Input Level	V_{IHI}	2.0		$V_{CC}+0.3$	V	
I VID Type Buffer (GP62* to GP67*)						
Low Input Level	V_{ILI}			0.4	V	(Note 28.11)
High Input Level	V_{IHI}	0.8		$V_{CC}+0.3$	V	
IOD Type Buffer (SCL, SDA, PWM1, PWM2, PWM3/ADDRESS ENABLE, nHWM_INT)						
Low Input Level	V_{ILI}			0.8	V	
High Input Level	V_{IHI}	2.0		$V_{CC}+0.3$	V	
Hysteresis	V_{HYS}		500		mV	
Low Output Level	V_{OL}			0.4	V	$I_{OL} = +4.0 \text{ mA}$ (Note 28.9)

HARDWARE MONITORING BLOCK ($T_A = -40^{\circ}\text{C} - +85^{\circ}\text{C}$, $\text{HVTR} = +3.3\text{ V} \pm 10\%$)						
Parameter	Symbol	Min	Typ	Max	Units	Comments
Leakage Current (ALL - Digital)						(Note 28.8)
Input High Current	$I_{LEAK_{IH}}$			10	μA	$V_{IN} = V_{CC}$
Input Low Current	$I_{LEAK_{IL}}$			-10	μA	$V_{IN} = 0\text{V}$
Digital Input Capacitance	C_{IN}			10	pF	
V_{CC} Supply Current						All outputs open, all inputs transitioning from/to 0V to/from 3.3V.
Active Mode	I_{CC}			3	mA	
Sleep Mode	I_{CC}			500	μA	
Shutdown Mode	I_{CC}			3	μA	

Notes:

- Voltages are measured from the local ground potential, unless otherwise specified.
- Typical values are at $T_A=25^{\circ}\text{C}$ and represent most likely parametric norm.
- The maximum allowable power dissipation at any temperature is $PD = (T_{Jmax} - T_A) / QJA$.
- Timing specifications are tested at the TTL logic levels, $V_{IL}=0.4\text{V}$ for a falling edge and $V_{IH}=2.4\text{V}$ for a rising edge. TRI-STATE output voltage is forced to 1.4V.

Note 28.1 All leakage currents are measured with all pins in high impedance.

Note 28.2 These values are estimated. They will be updated after Characterization. Contact SMSC for the latest values.

Note 28.3 The minimum value given for V_{TR} applies when V_{CC} is active. When V_{CC} is 0V, the minimum V_{TR} is 0V.

Note 28.4 Max I_{TRI} with $V_{CC} = 3.3\text{V}$ (nominal) is 10mA
Max I_{TRI} with $V_{CC} = 0\text{V}$ (nominal) is 250uA

Note 28.5 TUE (Total Unadjusted Error) includes Offset, Gain and Linearity errors of the ADC.

Note 28.6 Total Monitoring Cycle Time for cycle mode includes a one second delay plus all temperature conversions and all analog input voltage conversions.

Note 28.7 See PME_STS1 for conversion cycle timing for all averaging options. Only the nominal default case is shown in this section.

Note 28.8 All leakage currents are measured with all pins in high impedance.

Note 28.9 The low output level for PWM pins is actually +8.0mA.

Note 28.10 The h/w monitor analog block implements a 10-bit ADC. The output of this ADC goes to an average block, which can be configured to accumulate the averaged value of the analog inputs. The amount of averaging is programmable. The output of the averaging block produce a 12-bit temperature or voltage reading value. The 8 MSbits go to the reading register and the 4 LSbits to the A/D LSb register.

Note 28.11 Other platform components may use VID inputs and may require tighter limits.

Datasheet

28.3 Capacitance Values for Pins

The input and output capacitance applies to both the Super I/O Block and the Hardware Monitoring Block digital pins.

Table 28.2 Capacitance $T_A = 25$; $f_c = 1\text{MHz}$; $V_{CC} = 3.3\text{V} \pm 10\%$

LIMITS						
PARAMETER	SYMBOL	MIN	TYP	MAX	UNIT	TEST CONDITION
Clock Input Capacitance	C_{IN}			20	pF	All pins except pin under test tied to AC ground
Input Capacitance	C_{IN}			10	pF	
Output Capacitance	C_{OUT}			20	pF	

Note: The input capacitance of a port is measured at the connector pins.



Chapter 29 Timing Diagrams

For the Timing Diagrams shown, the following capacitive loads are used on outputs.

NAME	CAPACITANCE TOTAL (PF)
SER_IRQ	50
LAD [3:0]	50
LDRQ#	50
nDIR	240
nSTEP	240
nDS0	240
PD[0:7]	240
nSTROBE	240
nALF	240
KDAT	240
KCLK	240
MDAT	240
MCLK	240
LED1	50
LED2	50
TXD1	50
TXD2	50
TXD3	50
TXD4	50
TXD5	50
TXD6	50

29.1 Power Up Timing

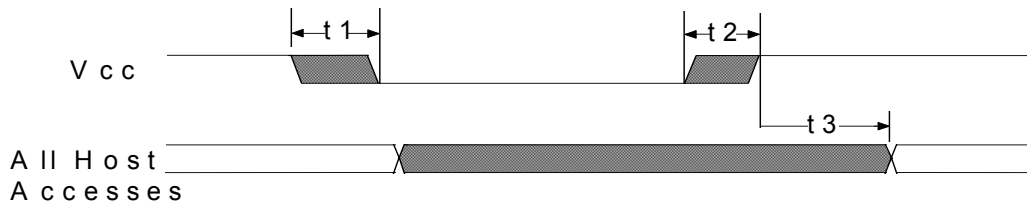

Figure 29.1 Power-Up Timing

NAME	DESCRIPTION	MIN	TYP	MAX	UNITS
t1	Vcc Slew from 2.7V to 0V	300			?s
t2	Vcc Slew from 0V to 2.7V	100			?s
t3	All Host Accesses After Power-up (See Note 29.1)	125		500	?s

Note 29.1 Internal write-protection period after Vcc passes 2.7 volts on power-up

29.2 Input Clock Timing

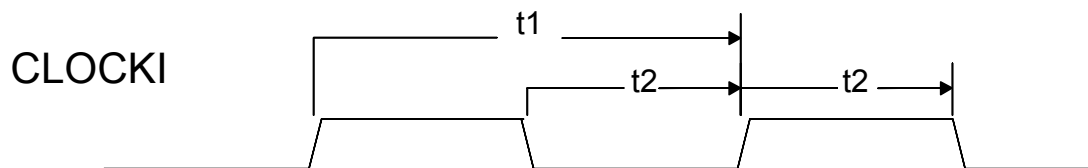

Figure 29.2 Input Clock Timing

NAME	DESCRIPTION	MIN	TYP	MAX	UNITS
t1	Clock Cycle Time for 14.318MHZ		69.84		ns
t2	Clock High Time/Low Time for 14.318MHz	20	35		ns
	Clock Rise Time/Fall Time (not shown)			5	ns

Datasheet

29.3 LPC Interface Timing

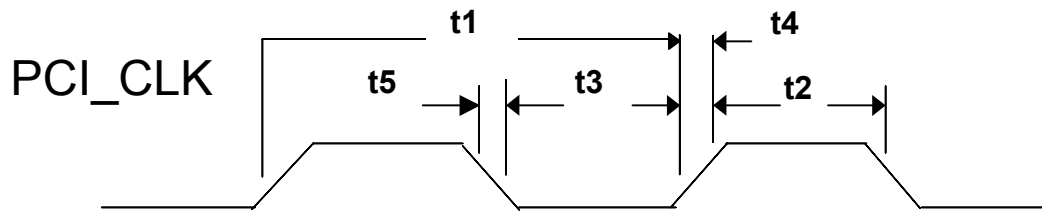

Figure 29.3 PCI Clock Timing

NAME	DESCRIPTION	MIN	TYP	MAX	UNITS
t1	Period	30		33.3	nsec
t2	High Time	12			nsec
t3	Low Time	12			nsec
t4	Rise Time			3	nsec
t5	Fall Time			3	nsec

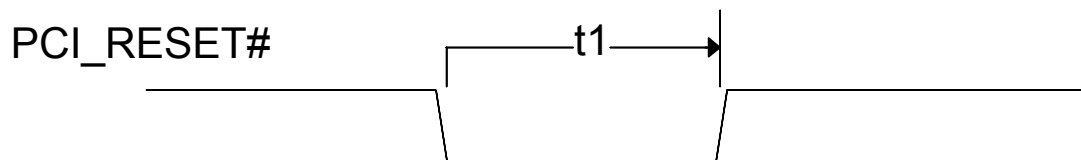
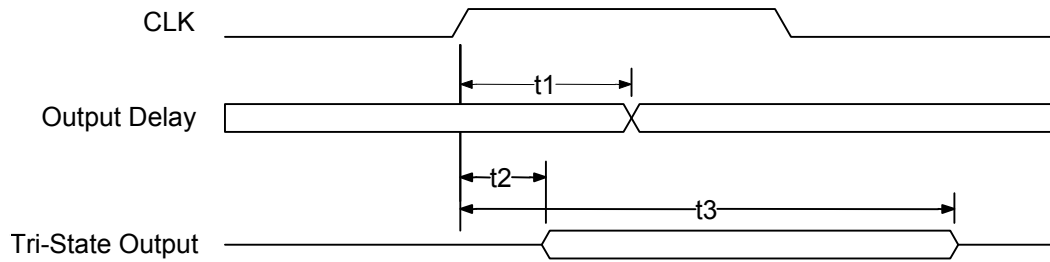
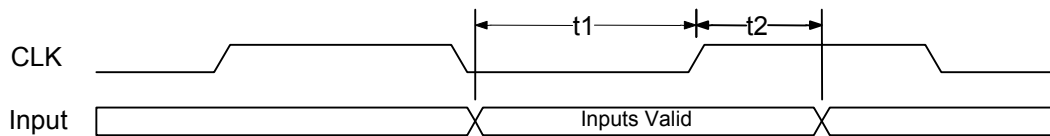

Figure 29.4 Reset Timing

NAME	DESCRIPTION	MIN	TYP	MAX	UNITS
t1	PCI_RESET# width	1			ms

Figure 29.5 Output Timing Measurement Conditions, LPC Signals

NAME	DESCRIPTION	MIN	TYP	MAX	UNITS
t1	CLK to Signal Valid Delay – Bused Signals	2		11	ns
t2	Float to Active Delay	2		11	ns
t3	Active to Float Delay			28	ns

Figure 29.6 Input Timing Measurement Conditions, LPC Signals

NAME	DESCRIPTION	MIN	TYP	MAX	UNITS
t1	Input Set Up Time to CLK – Bused Signals	7			ns
t2	Input Hold Time from CLK	0			ns

Note: L1=Start; L2=CYCTYP+DIR; L3=Sync of 0000

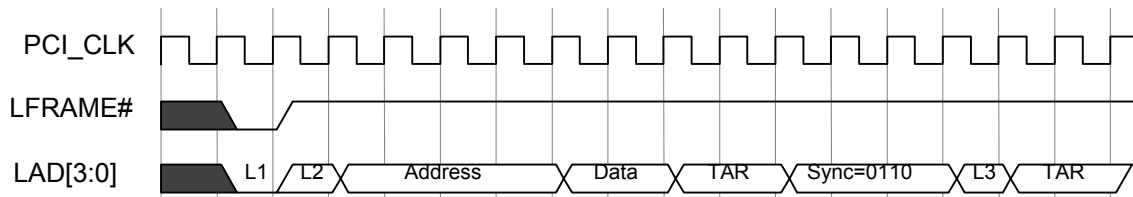
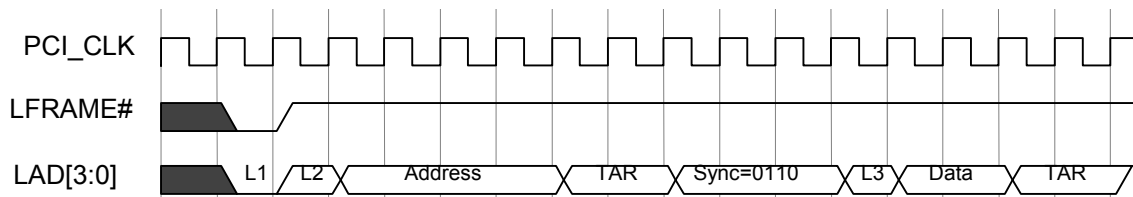

Figure 29.7 I/O Write



Note: L1=Start; L2=CYCTYP+DIR; L3=Sync of 0000

Figure 29.8 I/O Read

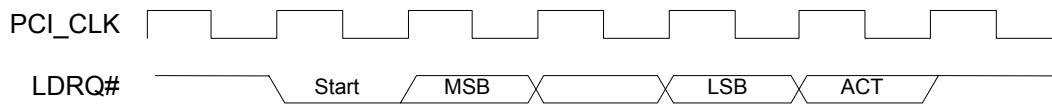
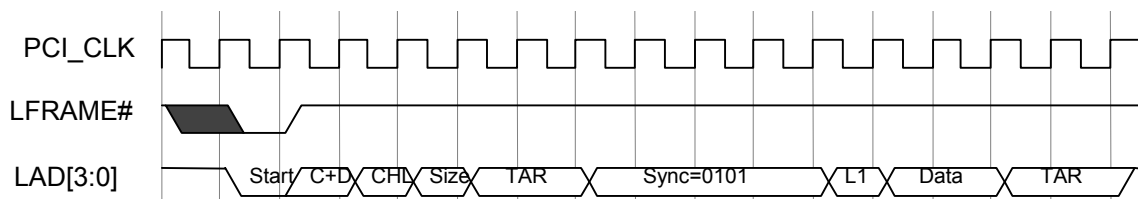
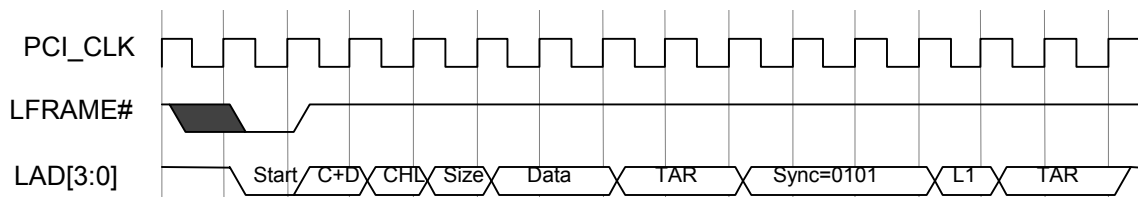

Figure 29.9 DMA Request Assertion through LDRQ#



Note: L1=Sync of 0000

Figure 29.10 DMA Write (First Byte)



Note: L1=Sync of 0000

Figure 29.11 DMA Read (First Byte)

29.4 Floppy Disk Controller Timing

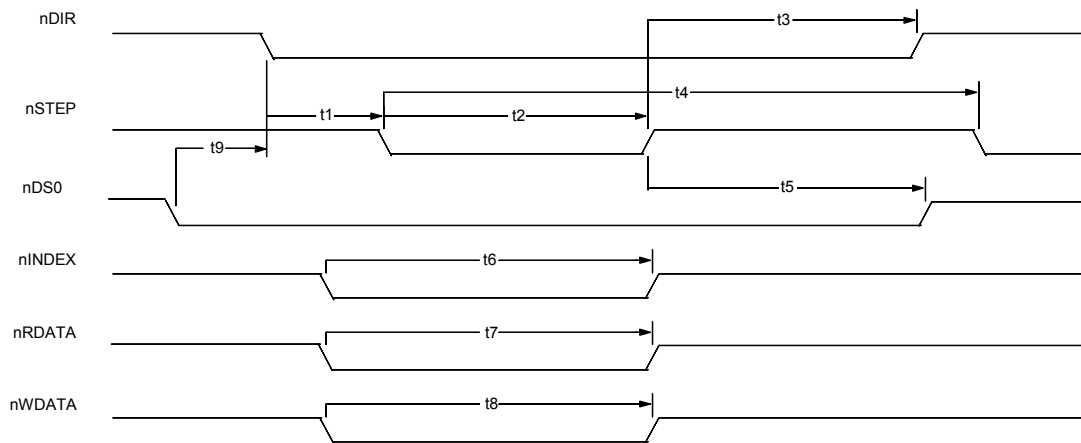

Figure 29.12 Floppy Disk Drive Timing (AT Mode Only)

NAME	DESCRIPTION	MIN	TYP	MAX	UNITS
t1	nDIR Set Up to STEP Low		4		X*
t2	nSTEP Active Time Low		24		X*
t3	nDIR Hold Time after nSTEP		96		X*
t4	nSTEP Cycle Time		132		X*
t5	nDS0 Hold Time from nSTEP Low (Note 29.2)		20		X*
t6	nINDEX Pulse Width		2		X*
t7	nRDATA Active Time Low		40		ns
t8	nWDATA Write Data Width Low		.5		Y*
t9	nDS0 Setup Time nDIR Low (Note 29.2)	0			ns

*X specifies one MCLK period and Y specifies one WCLK period.

MCLK = 16 x Data Rate (at 500 kb/s MCLK = 8 MHz)

WCLK = 2 x Data Rate (at 500 kb/s WCLK = 1 MHz)

Note 29.2 The DS0 setup and hold times must be met by software.

Datasheet

29.5 Parallel Port Timing

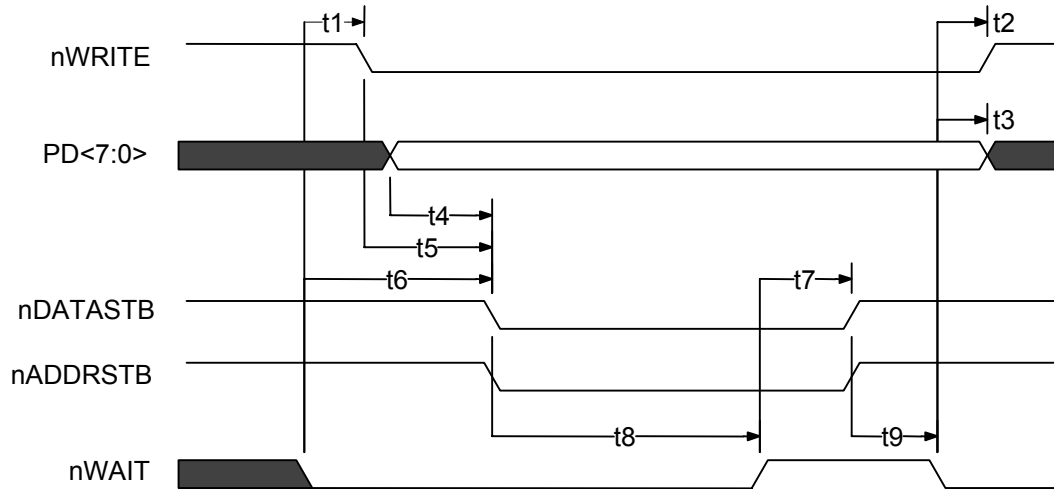
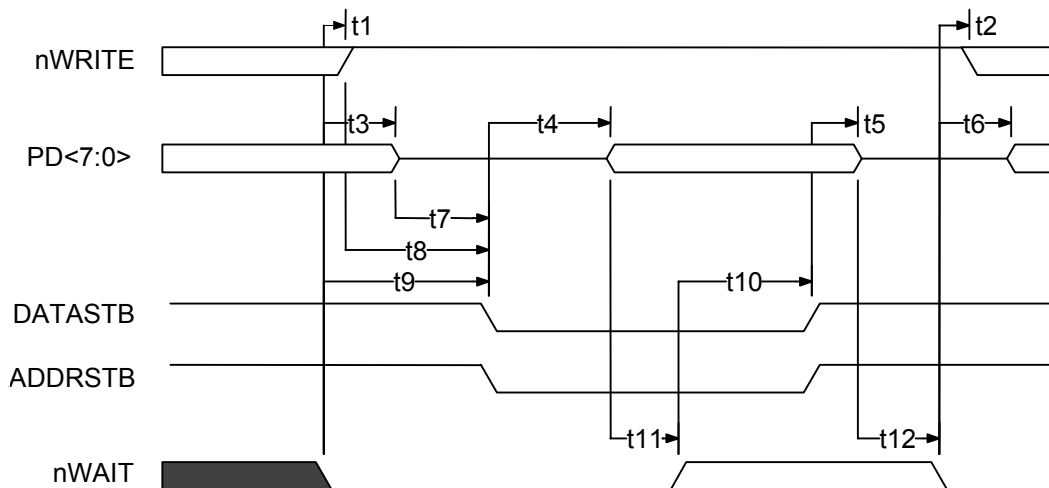

Figure 29.13 EPP 1.9 Data or Address Write Cycle

NAME	DESCRIPTION	MIN	TYP	MAX	UNITS
t1	nWAIT Asserted to nWRITE Asserted (See Note 29.3)	60		185	ns
t2	nWAIT Asserted to nWRITE Change (See Note 29.3)	60		185	ns
t3	nWAIT Asserted to PDATA Invalid (See Note 29.3)	0			ns
t4	PDATA Valid to Command Asserted	10			ns
t5	nWRITE to Command Asserted	5		35	ns
t6	nWAIT Asserted to Command Asserted (See Note 29.3)	60		210	ns
t7	nWAIT Deasserted to Command Deasserted (See Note 29.3)	60		190	ns
t8	Command Asserted to nWAIT Deasserted	0		10	?s
t9	Command Deasserted to nWAIT Asserted	0			ns

Note 29.3 nWAIT must be filtered to compensate for ringing on the parallel bus cable. nWAIT is considered to have settled after it does not transition for a minimum of 50 nsec

Figure 29.14 EPP 1.9 Data or Address Read Cycle

NAME	DESCRIPTION	MIN	TYP	MAX	UNITS
t1	nWAIT Asserted to nWRITE Deasserted	0		185	ns
t2	nWAIT Asserted to nWRITE Modified (Notes 1,2)	60		190	ns
t3	nWAIT Asserted to PDATA Hi-Z (Note 1)	60		180	ns
t4	Command Asserted to PDATA Valid	0			ns
t5	Command Deasserted to PDATA Hi-Z	0			ns
t6	nWAIT Asserted to PDATA Driven (Note 1)	60		190	ns
t7	PDATA Hi-Z to Command Asserted	0		30	ns
t8	nWRITE Deasserted to Command	1			ns
t9	nWAIT Asserted to Command Asserted	0		195	ns
t10	nWAIT Deasserted to Command Deasserted (Note 1)	60		180	ns
t11	PDATA Valid to nWAIT Deasserted	0			ns
t12	PDATA Hi-Z to nWAIT Asserted	0			µs

Notes:

- nWAIT is considered to have settled after it does not transition for a minimum of 50 ns.
- When not executing a write cycle, EPP nWRITE is inactive high.

Datasheet

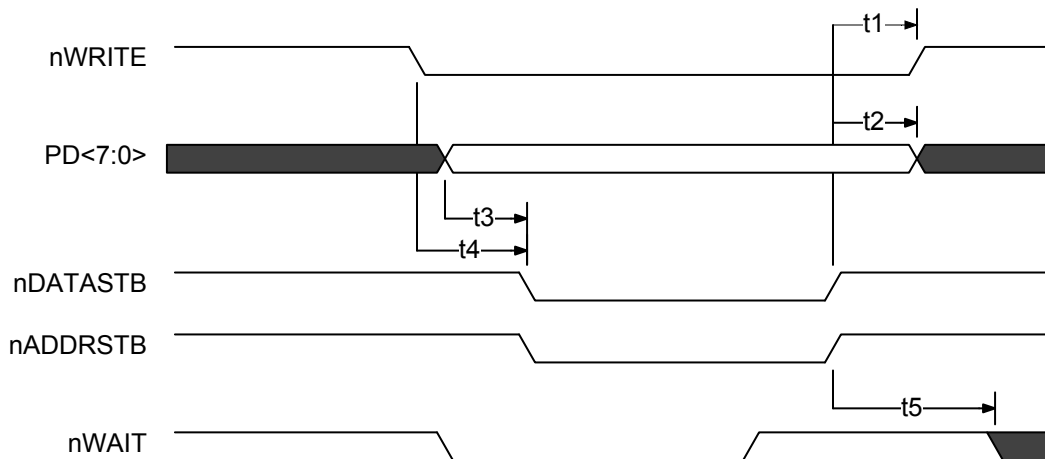

Figure 29.15 EPP 1.7 Data or Address Write Cycle

NAME	DESCRIPTION	MIN	TYP	MAX	UNITS
t1	Command Deasserted to nWRITE Change	0		40	ns
t2	Command Deasserted to PDATA Invalid	50			ns
t3	PDATA Valid to Command Asserted	10		35	ns
t4	nWRITE to Command	5		35	ns
t5	Command Deasserted to nWAIT Deasserted	0			ns

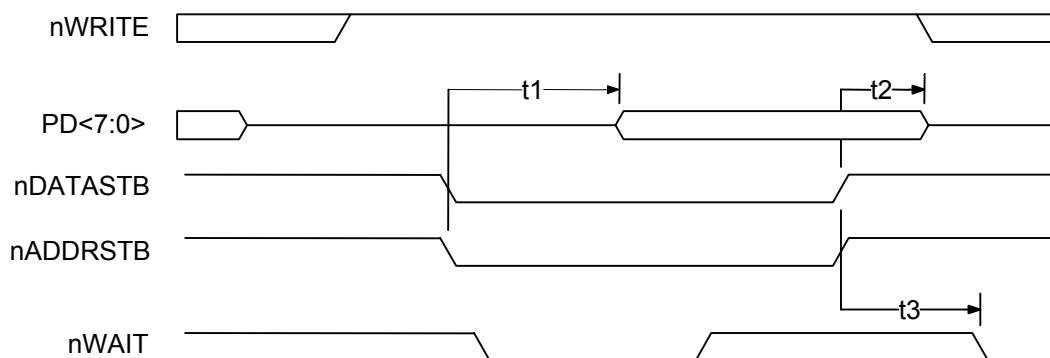

Figure 29.16 EPP 1.7 Data or Address Read Cycle

NAME	DESCRIPTION	MIN	TYP	MAX	UNITS
t1	Command Asserted to PDATA Valid	0			ns
t2	Command Deasserted to PDATA Hi-Z	0			ns
t3	Command Deasserted to nWAIT Deasserted	0			ns

ECP PARALLEL PORT TIMING

Parallel Port FIFO (Mode 101)

The standard parallel port is run at or near the peak 500KBytes/sec allowed in the forward direction using DMA. The state machine does not examine nACK and begins the next transfer based on Busy. Refer to [Figure 29.17 on page 357](#).

ECP Parallel Port Timing

The timing is designed to allow operation at approximately 2.0 Mbytes/sec over a 15ft cable. If a shorter cable is used then the bandwidth will increase.

Forward-Idle

When the host has no data to send it keeps HostClk (nStrobe) high and the peripheral will leave PeriphClk (Busy) low.

Forward Data Transfer Phase

The interface transfers data and commands from the host to the peripheral using an interlocked PeriphAck and HostClk. The peripheral may indicate its desire to send data to the host by asserting nPeriphRequest.

The Forward Data Transfer Phase may be entered from the Forward-Idle Phase. While in the Forward Phase the peripheral may asynchronously assert the nPeriphRequest (nFault) to request that the channel be reversed. When the peripheral is not busy it sets PeriphAck (Busy) low. The host then sets HostClk (nStrobe) low when it is prepared to send data. The data must be stable for the specified setup time prior to the falling edge of HostClk. The peripheral then sets PeriphAck (Busy) high to acknowledge the handshake. The host then sets HostClk (nStrobe) high. The peripheral then accepts the data and sets PeriphAck (Busy) low, completing the transfer. This sequence is shown in [Figure 29.18 on page 358](#).

The timing is designed to provide 3 cable round-trip times for data setup if Data is driven simultaneously with HostClk (nStrobe).

Reverse-Idle Phase

The peripheral has no data to send and keeps PeriphClk high. The host is idle and keeps HostAck low.

Reverse Data Transfer Phase

The interface transfers data and commands from the peripheral to the host using an interlocked HostAck and PeriphClk.

The Reverse Data Transfer Phase may be entered from the Reverse-Idle Phase. After the previous byte has been accepted the host sets HostAck (nALF) low. The peripheral then sets PeriphClk (nACK) low when it has data to send. The data must be stable for the specified setup time prior to the falling edge of PeriphClk. When the host is ready to accept a byte it sets HostAck (nALF) high to acknowledge the handshake. The peripheral then sets PeriphClk (nACK) high. After the host has accepted the data, it sets HostAck (nALF) low, completing the transfer. This sequence is shown in [Figure 29.19 on page 359](#).

Output Drivers

To facilitate higher performance data transfer, the use of balanced CMOS active drivers for critical signals (Data, HostAck, HostClk, PeriphAck, PeriphClk) are used in ECP Mode. Because the use of active drivers can present compatibility problems in Compatible Mode (the control signals, by tradition, are specified as open-drain), the drivers are dynamically changed from open-drain to push-pull. The timing for the dynamic driver change is specified in the *IEEE 1284 Extended Capabilities Port Protocol and ISA Interface Standard, Rev. 1.14*, July 14, 1993, available from Microsoft. The dynamic driver change must be implemented properly to prevent glitching the outputs.

Datasheet

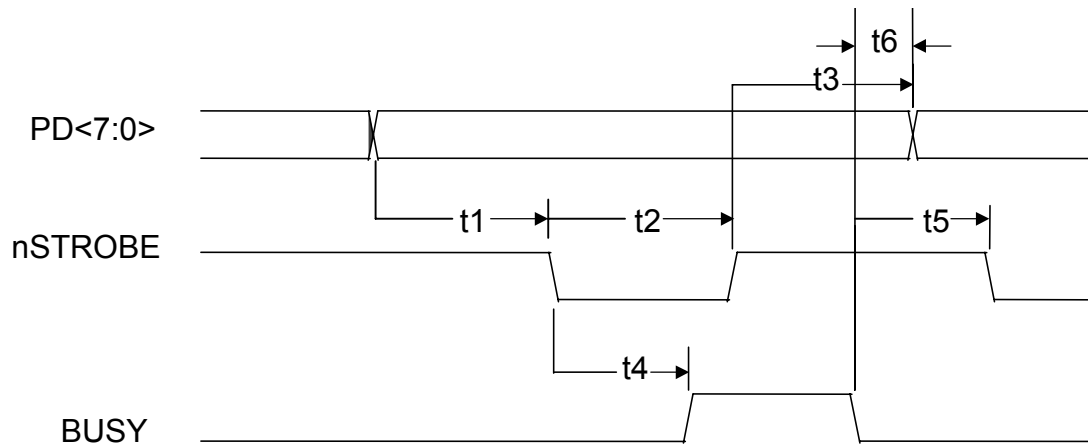
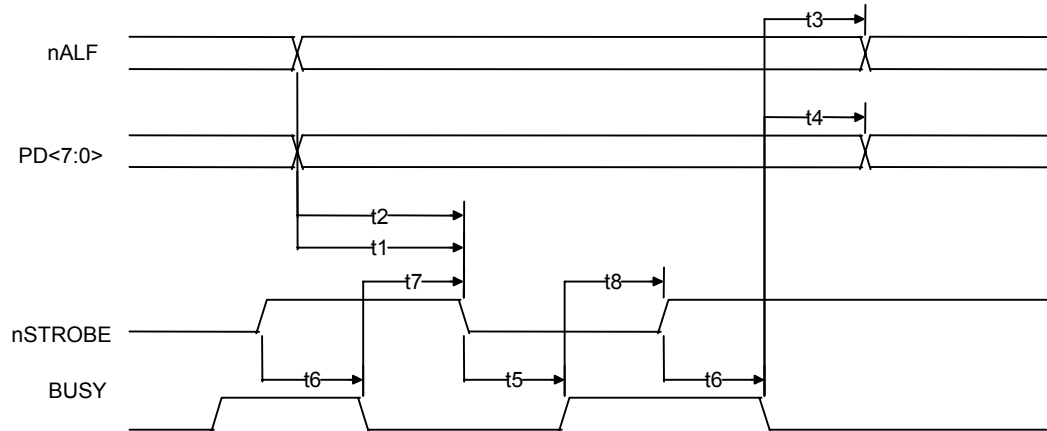

Figure 29.17 Parallel Port FIFO Timing

NAME	DESCRIPTION	MIN	TYP	MAX	UNITS
t1	PDATA Valid to nSTROBE Active	600			ns
t2	nSTROBE Active Pulse Width	600			ns
t3	PDATA Hold from nSTROBE Inactive (See Note 29.4)	450			ns
t4	nSTROBE Active to BUSY Active			500	ns
t5	BUSY Inactive to nSTROBE Active	680			ns
t6	BUSY Inactive to PDATA Invalid (See Note 29.4)	80			ns

Note 29.4 The data is held until BUSY goes inactive or for time t3, whichever is longer. This only applies if another data transfer is pending. If no other data transfer is pending, the data is held indefinitely.

Figure 29.18 ECP Parallel Port Forward Timing

NAME	DESCRIPTION	MIN	TYP	MAX	UNITS
t1	nALF Valid to nSTROBE Asserted	0		60	ns
t2	PDATA Valid to nSTROBE Asserted	0		60	ns
t3	BUSY Deasserted to nALF Changed (Notes 1,2)	80		180	ns
t4	BUSY Deasserted to PDATA Changed (Notes 1,2)	80		180	ns
t5	nSTROBE Asserted to Busy Asserted	0			ns
t6	nSTROBE Deasserted to Busy Deasserted	0			ns
t7	BUSY Deasserted to nSTROBE Asserted (Notes 1,2)	80		200	ns
t8	BUSY Asserted to nSTROBE Deasserted (Note 2)	80		180	ns

Notes:

1. Maximum value only applies if there is data in the FIFO waiting to be written out.
2. BUSY is not considered asserted or deasserted until it is stable for a minimum of 75 to 130 ns.

Datasheet

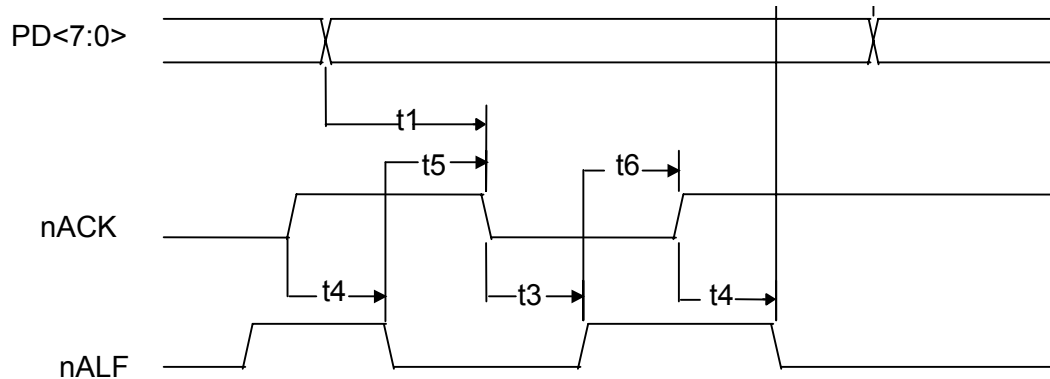

Figure 29.19 ECP Parallel Port Reverse Timing

NAME	DESCRIPTION	MIN	TYP	MAX	UNITS
t1	PDATA Valid to nACK Asserted	0			ns
t2	nALF Deasserted to PDATA Changed	0			ns
t3	nACK Asserted to nALF Deasserted (Notes 1,2)	80		200	ns
t4	nACK Deasserted to nALF Asserted (Note 2)	80		200	ns
t5	nALF Asserted to nACK Asserted	0			ns
t6	nALF Deasserted to nACK Deasserted	0			ns

Notes:

1. Maximum value only applies if there is room in the FIFO and terminal count has not been received. ECP can stall by keeping nALF low.
2. nACK is not considered asserted or deasserted until it is stable for a minimum of 75 to 130 ns.

29.6 IR Timing

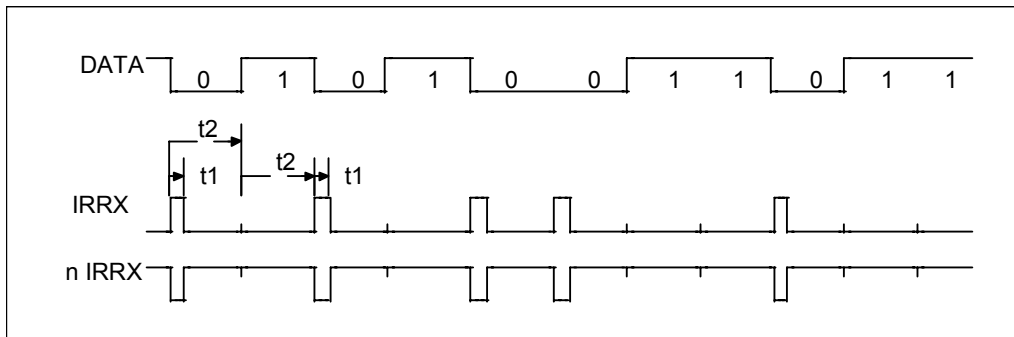

	Parameter	min	typ	max	units
t1	Pulse Width at 115kbaud	1.4	1.6	2.71	µs
t1	Pulse Width at 57.6kbaud	1.4	3.22	3.69	µs
t1	Pulse Width at 38.4kbaud	1.4	4.8	5.53	µs
t1	Pulse Width at 19.2kbaud	1.4	9.7	11.07	µs
t1	Pulse Width at 9.6kbaud	1.4	19.5	22.13	µs
t1	Pulse Width at 4.8kbaud	1.4	39	44.27	µs
t1	Pulse Width at 2.4kbaud	1.4	78	88.55	µs
t2	Bit Time at 115kbaud		8.68		µs
t2	Bit Time at 57.6kbaud		17.4		µs
t2	Bit Time at 38.4kbaud		26		µs
t2	Bit Time at 19.2kbaud		52		µs
t2	Bit Time at 9.6kbaud		104		µs
t2	Bit Time at 4.8kbaud		208		µs
t2	Bit Time at 2.4kbaud		416		µs

Notes:

1. Receive Pulse Detection Criteria: A received pulse is considered detected if the received pulse is a minimum of 1.41µs.
2. IRRX: L5, CRF1 Bit 0 = 1
nIRRX: L5, CRF1 Bit 0 = 0 (default)

Figure 29.20 IrDA Receive Timing

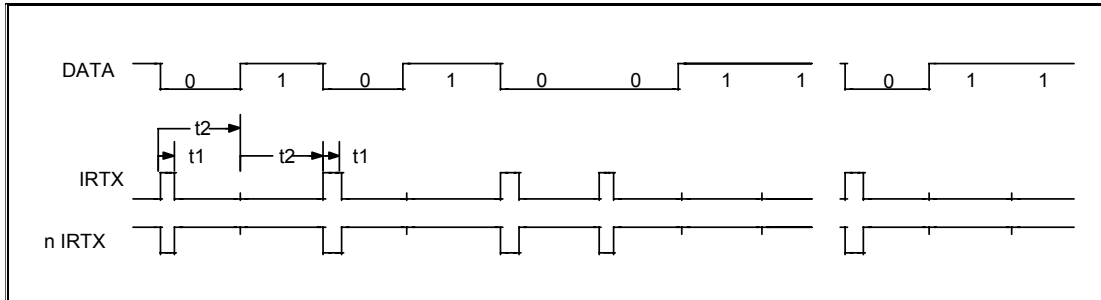
Datasheet

	Parameter	min	typ	max	units
t1	Pulse Width at 115kbaud	1.41	1.6	2.71	μ s
t1	Pulse Width at 57.6kbaud	1.41	3.22	3.69	μ s
t1	Pulse Width at 38.4kbaud	1.41	4.8	5.53	μ s
t1	Pulse Width at 19.2kbaud	1.41	9.7	11.07	μ s
t1	Pulse Width at 9.6kbaud	1.41	19.5	22.13	μ s
t1	Pulse Width at 4.8kbaud	1.41	39	44.27	μ s
t1	Pulse Width at 2.4kbaud	1.41	78	88.55	μ s
t2	Bit Time at 115kbaud		8.68		μ s
t2	Bit Time at 57.6kbaud		17.4		μ s
t2	Bit Time at 38.4kbaud		26		μ s
t2	Bit Time at 19.2kbaud		52		μ s
t2	Bit Time at 9.6kbaud		104		μ s
t2	Bit Time at 4.8kbaud		208		μ s
t2	Bit Time at 2.4kbaud		416		μ s

Notes:

- IrDA @ 115k is HPSIR compatible. IrDA @ 2400 will allow compatibility with HP95LX and 48SX.
- IRTX: L5, CRF1 Bit 1 = 1 (default)
nIRTX: L5, CRF1 Bit 1 = 0

Figure 29.21 IrDA Transmit Timing

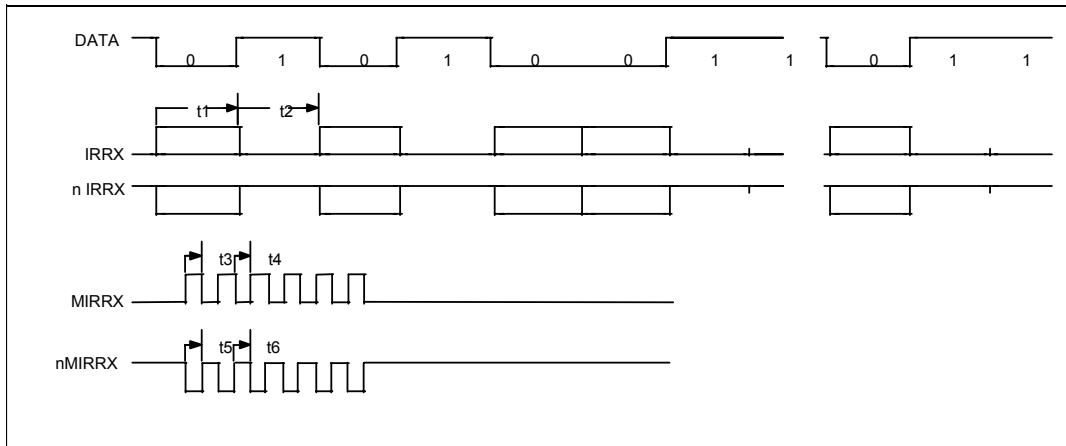

	Parameter	min	typ	max	units
t1	Modulated Output Bit Time				μ s
t2	Off Bit Time				μ s
t3	Modulated Output "On"	0.8	1	1.2	μ s
t4	Modulated Output "Off"	0.8	1	1.2	μ s
t5	Modulated Output "On"	0.8	1	1.2	μ s
t6	Modulated Output "Off"	0.8	1	1.2	μ s

Notes:

1. IRRX: L5, CRF1 Bit 0 = 1
 nIRRX: L5, CRF1 Bit 0 = 0 (default)
 MIRRX, nMIRRX are the modulated outputs

Figure 29.22 Amplitude Shift-Keyed IR Receive Timing

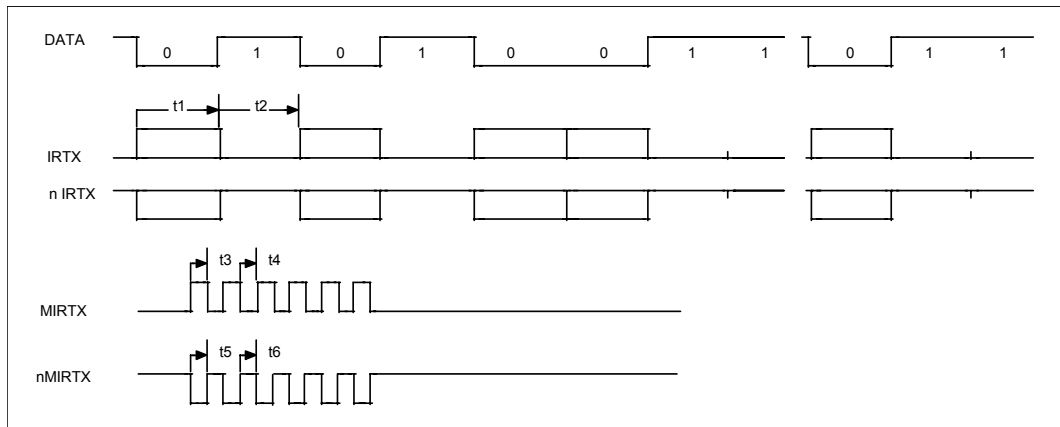

	Parameter	min	typ	max	units
t1	Modulated Output Bit Time				μ s
t2	Off Bit Time				μ s
t3	Modulated Output "On"	0.8	1	1.2	μ s
t4	Modulated Output "Off"	0.8	1	1.2	μ s
t5	Modulated Output "On"	0.8	1	1.2	μ s
t6	Modulated Output "Off"	0.8	1	1.2	μ s

Notes:
 1. IRTX: L5, CRF1 Bit 1 = 1 (default)
 nIRTX: L5, CRF1 Bit 1 = 0
 MIRTX, nMIRTX are the modulated outputs

Figure 29.23 Amplitude Shift-Keyed IR Transmit Timing

29.7 Serial IRQ Timing

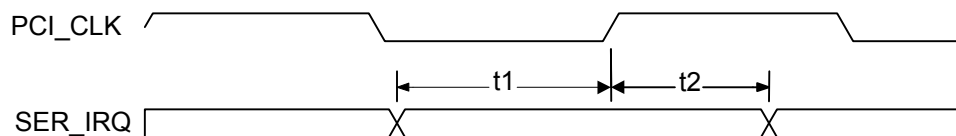

Figure 29.24 Setup and Hold Time

NAME	DESCRIPTION	MIN	TYP	MAX	UNITS
t1	SER_IRQ Setup Time to PCI_CLK Rising	7			nsec
t2	SER_IRQ Hold Time to PCI_CLK Rising	0			nsec

29.8 UART Interface Timing

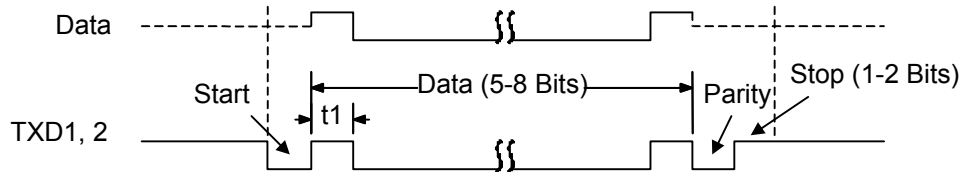

Figure 29.25 Serial Port Data

NAME	DESCRIPTION	MIN	TYP	MAX	UNITS
t1	Serial Port Data Bit Time		t_{BR}^1		nsec

t_{BR} is 1/Baud Rate. The Baud Rate is programmed through the divisor latch registers. Baud Rates have percentage errors indicated in the "Baud Rate" table in the "Serial Port" section.

29.9 Keyboard/Mouse Interface Timing

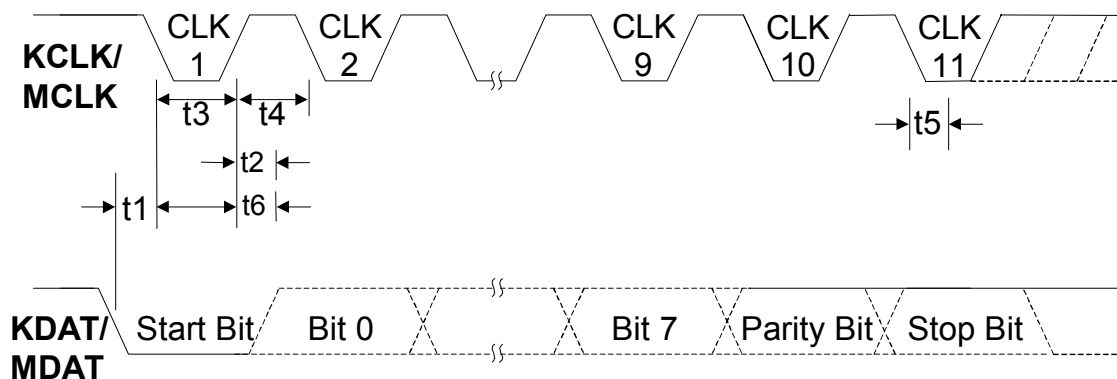

Figure 29.26 Keyboard/Mouse Receive/Send Data Timing

NAME	DESCRIPTION	MIN	TYP	MAX	UNITS
t1	Time from DATA transition to falling edge of CLOCK (Receive)	5		25	μ sec
t2	Time from rising edge of CLOCK to DATA transition (Receive)	5		T4-5	μ sec
t3	Duration of CLOCK inactive (Receive/Send)	30		50	μ sec
t4	Duration of CLOCK active (Receive/Send)	30		50	μ sec
t5	Time to keyboard inhibit after clock 11 to ensure the keyboard does not start another transmission (Receive)	>0		50	μ sec
t6	Time from inactive to active CLOCK transition, used to time when the auxiliary device samples DATA (Send)	5		25	μ sec

Datasheet

29.10 Resume Reset Signal Generation

nRSMRST signal is the reset output for the ICH resume well. This signal is used as a power on reset signal for the ICH.

SCH311X detects when VTR voltage raises above **VTRIP**, provides a delay before generating the rising edge of nRSMRST. See definition of **VTRIP** on page 365.

This delay, tRESET_DELAY, (**t1** on page 365) is nominally 32ms, starts when VTR voltage rises above the **VTRIP** trip point. If the VTR voltage falls below **VTRIP** the during tRESET_DELAY then the following glitch protection behavior is implemented: When the VTR voltage rises above **VTRIP**, nRSMRST will remain asserted the full tRESET_DELAY after which nRSMRST is deasserted.

On the falling edge there is minimal delay, tRESET_FALL.

Timing and voltage parameters are shown in Figure 29.27 and Table 29.1.

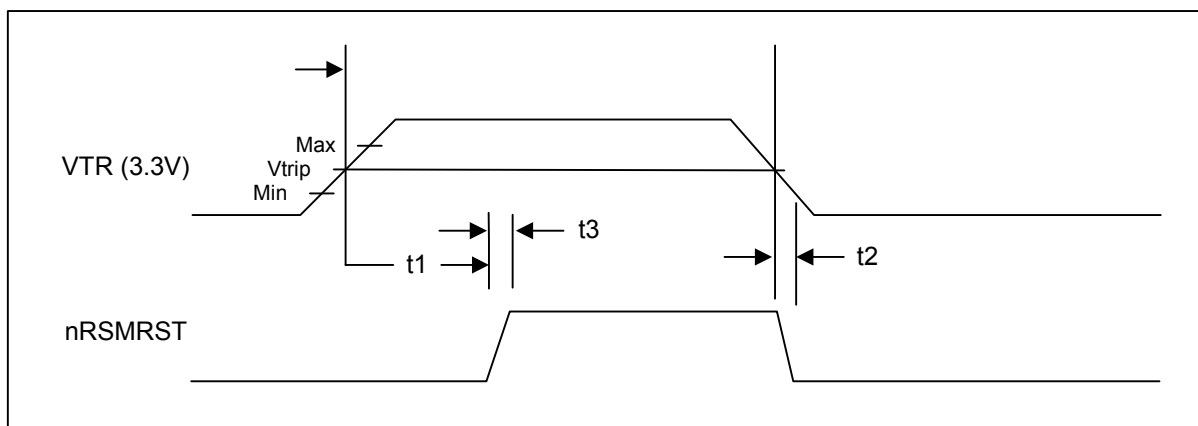

Figure 29.27 Resume Reset Sequence

Table 29.1 Resume Reset Timing

NAME	DESCRIPTION	MIN	TYP	MAX	UNITS	NOTES
t1	tRESET_DELAY: VTR active to nRSMRST inactive	140	350	560	msec	
t2	tRESET_FALL: VTR inactive to nRSMRST active (Glitch width allowance)			100	nsec	
t3	tRESET_RISE			100	nsec	
VTRIP	VTR low trip voltage	2.7	2.8	2.9	V	

APPLICATION NOTE: The 5 Volt Standby power supply must power up before or simultaneous with VTR, and must power down simultaneous with or after VTR (from ICH2 data sheet.) SCH311X does not have a 5 Volt Standby power supply input and does not respond to incorrect 5 Volt Standby power - VTR sequencing.

29.11 nLEDx Timing

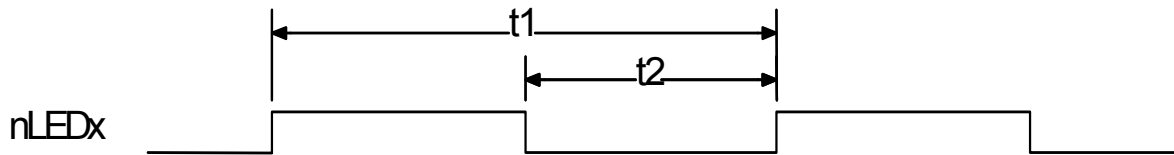

Figure 29.28 nLEDx Timing

NAME	DESCRIPTION	MIN	TYP	MAX	UNITS
t1	Period		1 or 2 ²	5.88 ¹	sec
t2	Blink ON Time	0	0.5 ²	1.52 ¹	sec

1. These Max values are due to internal Ring Oscillator. If 1Hz blink rate is selected for LED1 pin, the range will vary from 0.33Hz to 1.0Hz. If 0.5Hz blink rate is selected for LED1 pin, the range will vary from 0.17Hz to 0.5Hz.
 2. The blink rate is programmed through Bits[1:0] in LEDx register. When Bits[1:0]=00, LED is OFF. Bits[1:0]=01 indicates LED blink at 1Hz rate with a 50% duty cycle (0.5 sec ON, 0.5 sec OFF). Bits[1:0]=10 indicates LED blink at ½ Hz rate with a 25% duty cycle (0.5 sec ON, 1.5 sec OFF). When Bits[1:0]=11, LED is ON.

29.12 PWM Outputs

The following section shows the timing for the PWM[1:3] outputs.

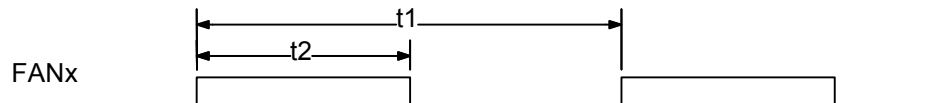

Figure 29.29 PWMx Output Timing

Table 29.2 Timing for PWM[1:3] Outputs

Name	Description	Min	Typ	Max	Units
t1	PWM Period (Note 1) - low frequency option - high frequency option	11.4 10.7		90.9 42.7	msec usec
t2	PWM High Time (Note 2)	0		99.6	%

Notes:

- This value is programmable by the PWM frequency bits located in the FRFx registers.
- The PWM High Time is based on a percentage of the total PWM period (min=0/256* T_{PWM} , max =255/256* T_{PWM}). During Spin-up the PWM High Time can reach a 100% or Full On. ($T_{PWM} = t1$).

Datasheet

Chapter 30 Package Outline

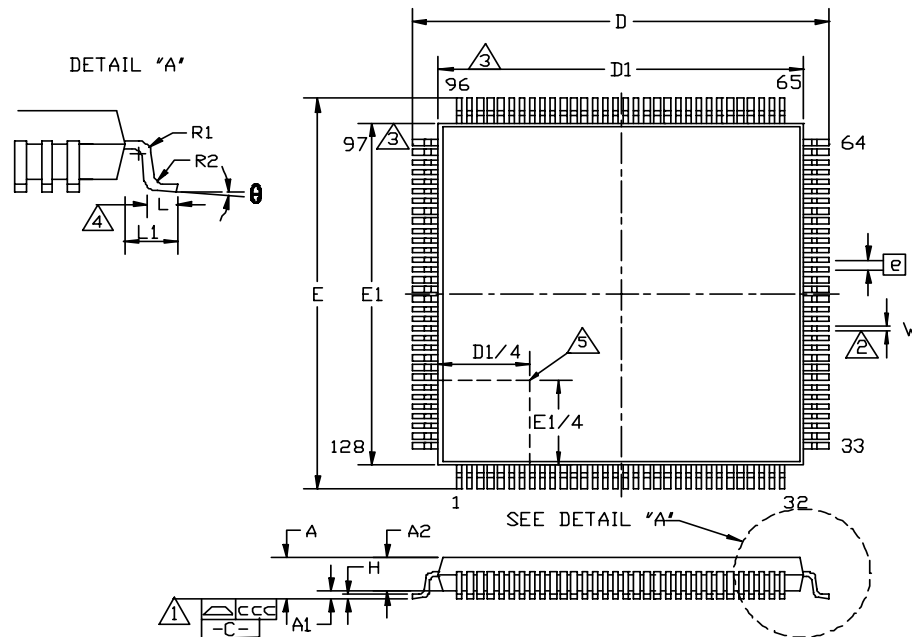

Figure 30.1 128 Pin VTQFP Package Outline

Table 30.1 128 Pin VTQFP Package Parameters

	MIN	NOMINAL	MAX	REMARKS
A	~	~	1.20	Overall Package Height
A1	0.05	~	0.15	Standoff
A2	0.95	~	1.05	Body Thickness
D	15.80	~	16.20	X Span
D1	13.80	~	14.20	X body Size
E	15.80	~	16.20	Y Span
E1	13.80	~	14.20	Y body Size
H	0.09	~	0.20	Lead Frame Thickness
L	0.45	0.60	0.75	Lead Foot Length
L1	~	1.00	~	Lead Length
e	0.40 Basic			Lead Pitch
q	0°	~	7°	Lead Foot Angle
W	0.13	0.18	0.23	Lead Width
R1	0.08	~	~	Lead Shoulder Radius
R2	0.08	~	0.20	Lead Foot Radius
ccc	~	~	0.08	Coplanarity

Notes:

- Controlling Unit: millimeter.
- Tolerance on the true position of the leads is ± 0.035 mm maximum.
- Package body dimensions D1 and E1 do not include the mold protrusion. Maximum mold protrusion is 0.25 mm.
- Dimension for foot length L measured at the gauge plane 0.25 mm above the seating plane.
- Details of pin 1 identifier are optional but must be located within the zone indicated.



Appendix A ADC Voltage Conversion

Table A.1 Analog-to-Digital Voltage Conversions for Hardware Monitoring Block

INPUT VOLTAGE				A/D OUTPUT	
+12 V	+5 V Note 30.1	+3.3 V Note 30.2	V _{CCPIN}	Decimal	Binary
<0.062	<0.026	<0.0172	<0.012	0	0000 0000
0.062–0.125	0.026–0.052	0.017–0.034	0.012–0.023	1	0000 0001
0.125–0.188	0.052–0.078	0.034–0.052	0.023–0.035	2	0000 0010
0.188–0.250	0.078–0.104	0.052–0.069	0.035–0.047	3	0000 0011
0.250–0.313	0.104–0.130	0.069–0.086	0.047–0.058	4	0000 0100
0.313–0.375	0.130–0.156	0.086–0.103	0.058–0.070	5	0000 0101
0.375–0.438	0.156–0.182	0.103–0.120	0.070–0.082	6	0000 0110
0.438–0.500	0.182–0.208	0.120–0.138	0.082–0.093	7	0000 0111
0.500–0.563	0.208–0.234	0.138–0.155	0.093–0.105	8	0000 1000
⋮	⋮	⋮	⋮	⋮	⋮
4.000–4.063	1.666–1.692	1.100–1.117	0.749–0.761	64 (1/4 Scale)	0100 0000
⋮	⋮	⋮	⋮	⋮	⋮
8.000–8.063	3.330–3.560	2.200–2.217	1.499–1.511	128 (1/2 Scale)	1000 0000
⋮	⋮	⋮	⋮	⋮	⋮
12.000–12.063	5.000–5.026	3.300–3.317	2.249–2.261	192 (3/4 Scale)	1100 0000
⋮	⋮	⋮	⋮	⋮	⋮
15.312–15.375	6.380–6.406	4.210–4.230	2.869–2.881	245	1111 0101
15.375–15.437	6.406–6.432	4.230–4.245	2.881–2.893	246	1111 0110
15.437–15.500	6.432–6.458	4.245–4.263	2.893–2.905	247	1111 0111
15.500–15.563	6.458–6.484	4.263–4.280	2.905–2.916	248	1111 1000
15.625–15.625	6.484–6.510	4.280–4.300	2.916–2.928	249	1111 1001
15.625–15.688	6.510–6.536	4.300–4.314	2.928–2.940	250	1111 1010
15.688–15.750	6.536–6.562	4.314–4.330	2.940–2.951	251	1111 1011
15.750–15.812	6.562–6.588	4.331–4.348	2.951–2.964	252	1111 1100
15.812–15.875	6.588–6.615	4.348–4.366	2.964–2.975	253	1111 1101
15.875–15.938	6.615–6.640	4.366–4.383	2.975–2.987	254	1111 1110
>15.938	>6.640	>4.383	>2.988	255	1111 1111

Note 30.1 The 5V input is a +5V nominal inputs. 2.5V input is a 2.5V nominal input.

Note 30.2 The VCC, VTR, and Vbat inputs are +3.3V nominal inputs. VCC and VTR are nominal 3.3V power supplies. Vbat is a nominal 3.0V power supply.





Datasheet

Appendix B Example Fan Circuits

The following figures show examples of circuitry on the board for the PWM outputs, tachometer inputs, and remote diodes. [Figure B.1](#) shows how the part can be used to control four fans by connecting two fans to one PWM output.

Note: These examples represent the minimum required components. Some designs may require additional components.

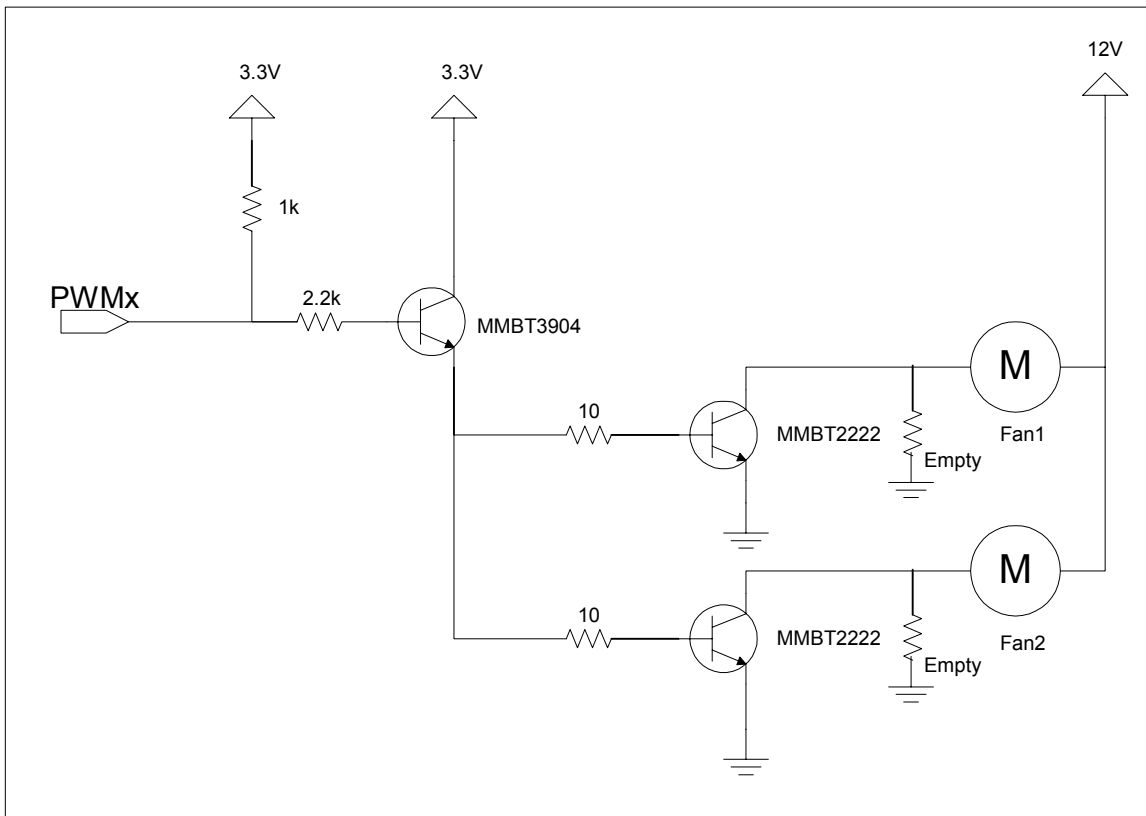

Figure B.1 Fan Drive Circuitry for Low Frequency Option (Apply to PWM Driving Two Fans)

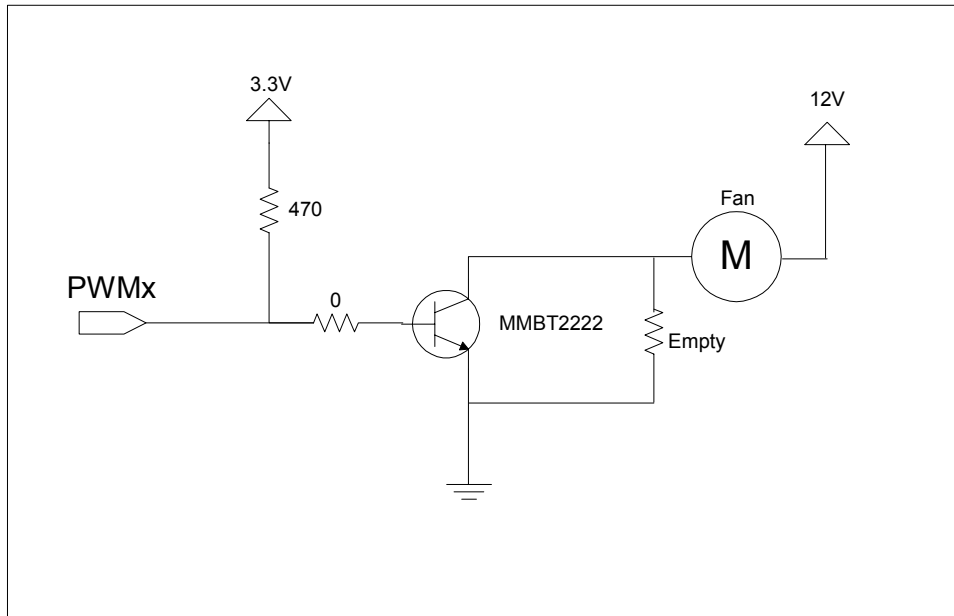

Figure B.2 Fan Drive Circuitry for Low Frequency Option (Apply to PWM Driving One Fan)

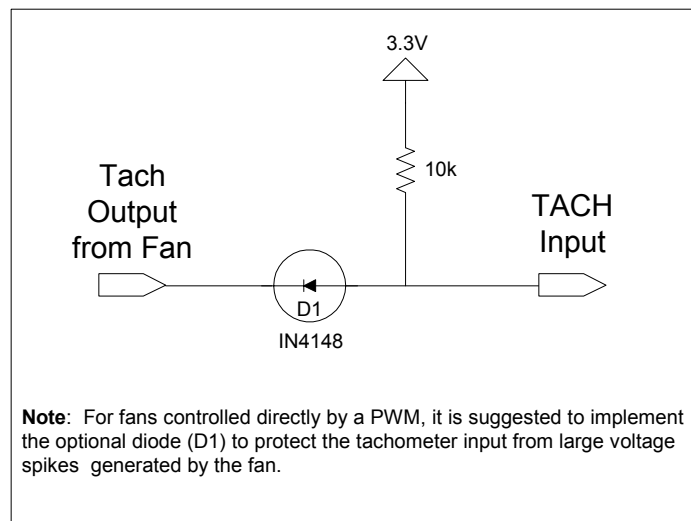

Figure B.3 Fan Tachometer Circuitry (Apply to Each Fan)

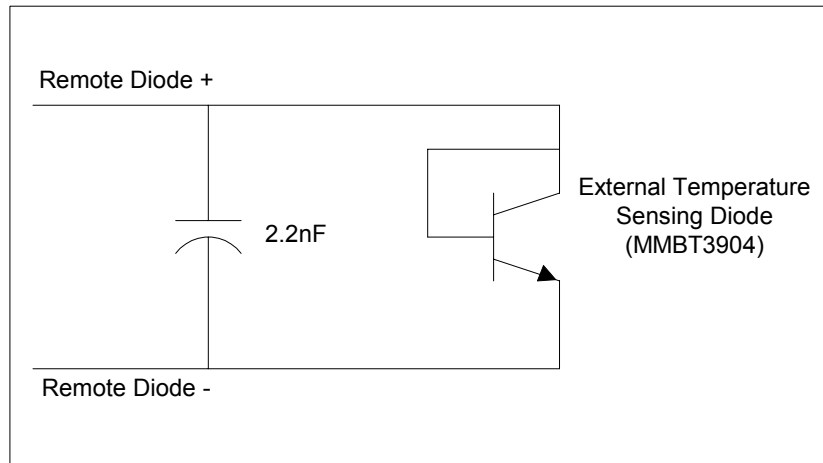

Figure B.4 Remote Diode (Apply to Remote2 Lines)

Notes:

1. 2.2nF cap is optional and should be placed close to the SCH311X if used.
2. The voltage at PWM3 must be at least 2.0V to avoid triggering Address Enable.
3. The Remote Diode + and Remote Diode - tracks should be kept close together, in parallel with grounded guard tracks on each side. Using wide tracks will help to minimize inductance and reduce noise pickup. A 10 mil track minimum width and spacing is recommended. See Figure B.5, "Suggested Minimum Track Width and Spacing".

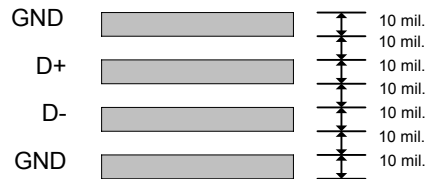

Figure B.5 Suggested Minimum Track Width and Spacing



Appendix C Test Mode

The SCH311X provides board test capability through the implementation of one XNOR chain and one XOR chain. The XNOR chain is dedicated to the Super I/O portion and the Hardware Monitoring Block of the device.

C.1 XNOR-Chain Test Mode Overview

XNOR-Chain test structure allows users to confirm that all pins are in contact with the motherboard during assembly and test operations. See [Figure C.1](#). When the chip is in the XNOR chain test mode, setting the state of any of the input pins to the opposite of its current state will cause the output of the chain to toggle.

The XNOR-Chain test structure must be activated to perform these tests. When the XNOR-Chain is activated, the SCH311X pin functions are disconnected from the device pins, which all become input pins except for one output pin at the end of XNOR-Chain.

The tests that are performed when the XNOR-Chain test structure is activated require the board-level test hardware to control the device pins and observe the results at the XNOR-Chain output pin.

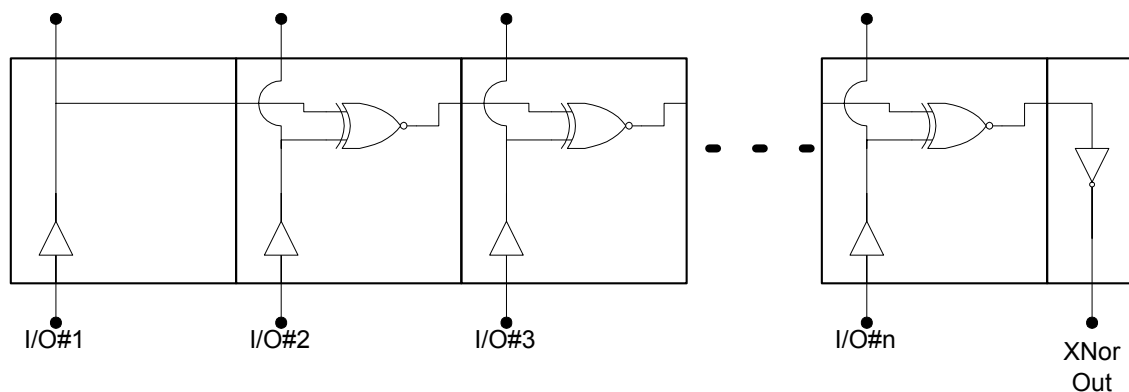

Figure C.1 XNOR-Chain Test Structure

C.1.1 Board Test Mode

Board test mode can be entered as follows:

On the rising (deasserting) edge of PCI_RESET#, drive LFRAME# low and drive LAD[0] low.

Exit board test mode as follows:

On the rising (deasserting) edge of PCI_RESET#, drive either LFRAME# or LAD[0] high.

See PME_STS1 for a description of this board test mode.

The PCI_RESET# pin is not included in the XNOR-Chain. The XNOR-Chain output pin# is TXD1. See the following subsections for more details.

Pin List of XNOR Chain

Pins 1-128 on the chip are inputs to the first XNOR chain, with the exception of the following:

- All power supply pins - HVTR, HVSS, VCC, VTR, and Vbat
- VSS and AVSS
- All analog inputs: Remote2-, Remote2+, Remote1-, Remote1+, VCCP_IN, +12V_IN, +5V_IN, +2.5V_IN

- TXD1 This is the chain output.
- PCI_RESET#.

To put the chip in the first XNOR chain test mode, tie LAD0 and LFRAME# low. Then toggle PCI_RESET# from a low to a high state. Once the chip is put into XNOR chain test mode, LAD0 and LFRAME# become part of the chain.

To exit the SIO XNOR chain test mode tie LAD0 or LFRAME# high. Then toggle PCI_RESET# from a low to a high state. A VCC POR will also cause the XNOR chain test mode to be exited. To verify the test mode has been exited, observe the output at TXD1. Toggling any of the input pins in the chain should not cause its state to change.

Setup of Super I/O XNOR Chain

Warning: Ensure power supply is off during setup.

- Connect the VSS, the AVSS, HVSS pins to ground.
- Connect the VCC, the VTR, and HVTR pins to 3.3V.
- Connect an oscilloscope or voltmeter to TXD1.
- All other pins should be tied to ground.

Testing

1. Turn power on.
2. With LAD0 and LFRAME# low, bring PCI_RESET# high. The chip is now in XNOR chain test mode. At this point, all inputs to the first XNOR chain are low. The output, on TXD1 should also be low. Refer to INITIAL CONFIG on [Table C.1](#).
3. Bring pin 110 high. The output on TXD1 (pin66) should go toggle. Refer to STEP ONE in [Table C.1](#).
4. In descending pin order, bring each input high. The output should switch states each time an input is toggled. Continue until all inputs are high. The output on TXD1 should now be low. Refer to END CONFIG in [Table C.1](#).
5. The current state of the chip is now represented by INITIAL CONFIG in [Table C.2](#).
6. Each input should now be brought low, starting at pin one and continuing in ascending order. Continue until all inputs are low. The output on TXD1 should now be low. Refer to [Table C.2](#).
7. To exit test mode, tie LAD0 (pin 19) OR LFRAME# high, and toggle PCI_RESET# from a low to a high state.

Table C.1 Toggling Inputs in Descending Order

	PIN 128	PIN 109	PIN 108	PIN 107	PIN 106	PIN ...	PIN 1	OUTPUT PIN 66
INITIAL CONFIG	L	L	L	L	L	L	L	H
STEP 1	H	L	L	L	L	L	L	L
STEP 2	H	H	L	L	L	L	L	H
STEP 3	H	H	H	L	L	L	L	L
STEP 4	H	H	H	H	L	L	L	H
STEP 5	H	H	H	H	H	L	L	L
...
STEP N	H	H	H	H	H	H	L	H
END CONFIG	H	H	H	H	H	H	H	L

Table C.2 Toggling Inputs in Ascending Order

	PIN 1	PIN 2	PIN 3	PIN 4	PIN 5	PIN ...	PIN 128	OUTPUT PIN 66
INITIAL CONFIG	H	H	H	H	H	H	H	L
STEP 1	L	H	H	H	H	H	H	H
STEP 2	L	L	H	H	H	H	H	L
STEP 3	L	L	L	H	H	H	H	H
STEP 4	L	L	L	L	H	H	H	L
STEP 5	L	L	L	L	L	H	H	H
...
STEP N	L	L	L	L	L	L	H	H
END CONFIG	L	L	L	L	L	L	L	H

