



81 and 65 MUX LCD Controller and Driver

High Uniformity of Contrast and no external components

Description

The EM6126 is an ultra-low power bit map controller and driver for full dot matrix monochrome STN LCD displays. The driving capability is **81 rows x 102 columns** or **65 rows x 118 columns** addressed by I²C or 3-wire interface. V_{LCD} is internally generated up to 11V without external components.

Key Features

- ❑ High accuracy of frame frequency and LCD voltage by laser trimming
- ❑ No external components
- ❑ OTP Trimming
- ❑ Generated LCD voltage on chip
- ❑ Partial display of 17 rows
- ❑ I²C and 3-wire interfaces
- ❑ LCD voltage digitally programmable 4.5V to 11V
- ❑ Selectable x5, x4, x3, x2 multiplier factor for V_{LCD}
- ❑ Supply voltage from low 2.4V up to 3.3V
- ❑ True Low Current:
 - $I_{HV}=124\mu A$
 - $I_{DD}=15\mu A$ (active)
 - $I_{DD}=0.1\mu A$ (sleep)
- ❑ Temperature compensation of V_{LCD} (4 coefficients)
- ❑ Oscillator for LCD refresh on chip
- ❑ Intermediate bias voltage generation on chip
- ❑ Available in die with gold bumps, COG

& BENEFITS

- ✓ Flexibility and easy to design-in
- ✓ Uniformity of contrast of all dies in production
- ✓ Usable with a wide range of modules
- ✓ No flickering
- ✓ Ideal for portable and mobile phones applications
- ✓ Save PCB space
- ✓ Cost effective

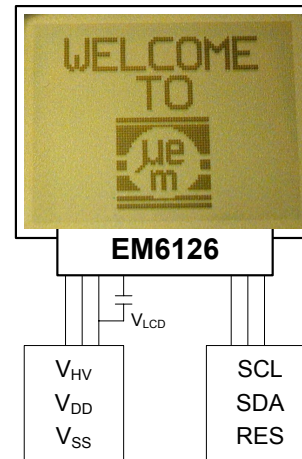

Typical Applications

- ❑ Mobile and DECT phones
- ❑ MP3 and DVD players
- ❑ Graphic calculators
- ❑ GPS, credit card readers
- ❑ Scales and utility meters
- ❑ Sporting & fishing devices

