

### ■ Features

- Maximum switching current: 3.5A
- Built-in ON/OFF control function
- Built-in soft start function to suppress overshoot of output voltage in power on sequence or ON/OFF control sequence
- Built-in oscillation circuit (Oscillation frequency: TYP. 150kHz)
- Built-in overheat protection function, overcurrent shut-down function
- Sleeve-packaged product
- Variable output voltage  
(Output variable range:  $V_{ref}$  to  $35V$ / $-V_{ref}$  to  $-30V$ )  
[Possible to select step-down output/inversing output according to external connection circuit]

### ■ Applications

- LCD monitors
- Car navigation systems
- Switching power supplies

### ■ Absolute Maximum Ratings

( $T_a=25^{\circ}C$ )

Parameter	Symbol	Rating	Unit
*1 Input voltage	$V_{IN}$	40	V
Error input voltage	$V_{ADJ}$	7	V
Input-output voltage	$V_{I-O}$	41	V
*2 Output – COM voltage	$V_{OUT}$	-1	V
*3 $V_{soft}$ terminal voltage	$V_{soft}$	-0.3 to +40	V
Switching current	$I_{SW}$	3.5	A
*4 Power dissipation	$P_D$	35	W
*5 Junction temperature	$T_j$	150	$^{\circ}C$
Operating temperature	$T_{opr}$	-20 to +85	$^{\circ}C$
Storage temperature	$T_{stg}$	-40 to +150	$^{\circ}C$
Soldering temperature	$T_{sol}$	260 (10s)	$^{\circ}C$

\*1 Voltage between  $V_{IN}$  terminal and COM terminal

\*2 Voltage between  $V_{OUT}$  terminal and COM terminal

\*3 Voltage between  $V_{SOFT}$  terminal and COM terminal

\*4  $P_D$ : With infinite heat sink

\*5 Overheat protection may operate at  $T_j=125^{\circ}C$  to  $150^{\circ}C$

• Please refer to the chapter " Handling Precautions ".

\* All specs and applications shown above subject to change without prior notice.

### ■ Electrical Characteristics (CP1032-ADJ)

(Unless otherwise specified, condition shall be  $V_{IN}=12V$ ,  $I_o=0.5A$ ,  $V_o=5V$ ,  $V_{soft}$  terminal=0.1 $\mu$ F,  $T_a=25^\circ C$ )

Parameter	Symbol	Conditions	MIN.	TYP.	MAX.	Unit
Output saturation voltage	$V_{SAT}$	$I_{sw}=3A$	-	1.4	1.8	V
Reference voltage	$V_{ref}$	-	1.235	1.26	1.285	V
Reference voltage temperature fluctuation	$\Delta V_{ref}$	$T_j=0$ to $125^\circ C$	-	$\pm 0.5$	-	%
Load regulation	$ R_{egL} $	$I_o=0.5$ to $3A$	-	0.2	1.5	%
Line regulation	$ R_{egI} $	$V_{IN}=8$ to $35V$	-	1	2.5	%
Efficiency	$\eta$	$I_o=3A$	-	80	-	%
Oscillation frequency	$f_o$	-	135	150	165	kHz
Oscillation frequency temperature fluctuation	$\Delta f_o$	$T_j=0$ to $125^\circ C$	-	$\pm 2$	-	%
Overcurrent detecting level	$I_L$	-	3.6	4.2	5.8	A
Charge current	$I_{CHG}$	②, ④ terminals is open, ⑤ terminal	-	-10	-	$\mu A$
Input threshold voltage	$V_{THL}$	Duty ratio=0%, ④ terminal=0V, ⑤ terminal	-	1.3	-	V
	$V_{THH}$	Duty ratio=100%, ④ terminals is open, ⑤ terminal	-	2.3	-	V
ON threshold voltage	$V_{TH(ON)}$	④ terminal=0V, ⑤ terminal	0.7	0.8	0.9	V
Overcurrent shutdown threshold voltage	$V_{THIL}$	⑤ terminal	3.8	4.6	5.5	V
Stand-by current	$I_{SD}$	$V_{IN}=40V$ , ⑤ terminal=0V	-	140	400	$\mu A$
Output OFF-state dissipation current	$I_{QS}$	$V_{IN}=40V$ , ⑤ terminal=0.9V	-	8	16	mA

### (CP1032-5.0V)

(Unless otherwise specified, condition shall be  $V_{IN}=12V$ ,  $I_o=0.5A$ ,  $V_o=5V$ ,  $V_{soft}$  terminal=0.1 $\mu$ F,  $T_a=25^\circ C$ )

Parameter	Symbol	Conditions	MIN.	TYP.	MAX.	Unit.	
Output Voltage	$V_{OUT}$	Test circuit of Figure2	4.9	5.0	5.1	V	
		0.5 $I_{LOAD}$ 3A Test circuit of Figure2	8V $V_{IN}$ 40V	4.8	5.0	5.2	V
		0.5 $I_{LOAD}$ 3A -40 $T_j$ 125 Test circuit of Figure2	8V $V_{IN}$ 40V	4.75	5.0	5.25	V
Efficiency		$I_{LOAD}=3A$		80		%	
Oscillator Frequency	$f_{osc}$		135	150	165	kHz	

\* All specs and applications shown above subject to change without prior notice.

## Chopper Regulators

### ■ Order Information

Package	Part Number	Packing Type	Marking
TO-263-5	CP1032 ADJ	Tape/Tube	CP1032 ADJ
	CP1032 5.0	Tape/Tube	CP1032 5.0
TO-220-5	CP1032 ADJ N	Tape/Tube	CP1032 ADJ
	CP1032 5.0 N	Tape/Tube	CP1032 5.0

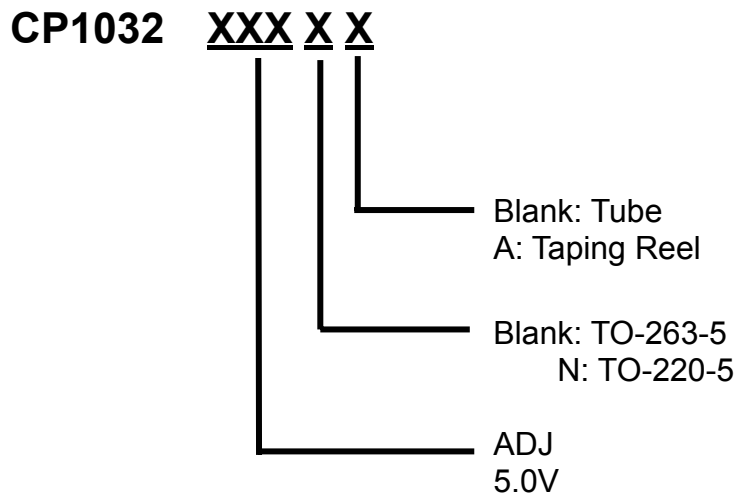

\* All specs and applications shown above subject to change without prior notice.

### ■ Connection Diagrams

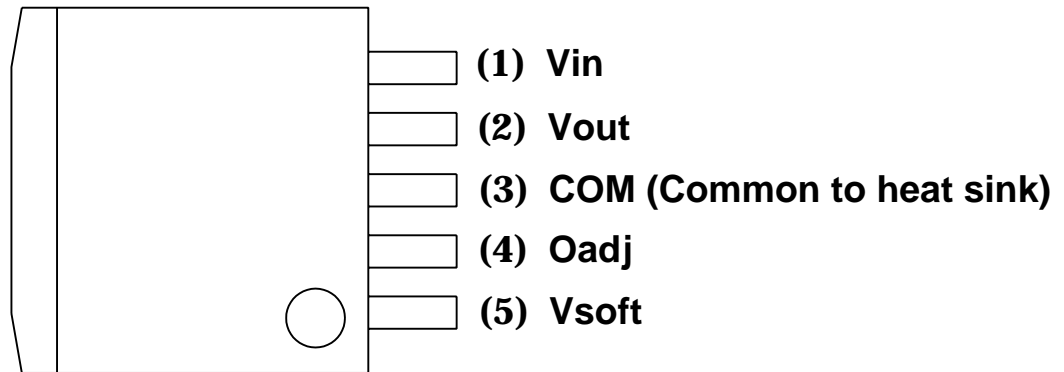

(TO-263-5)

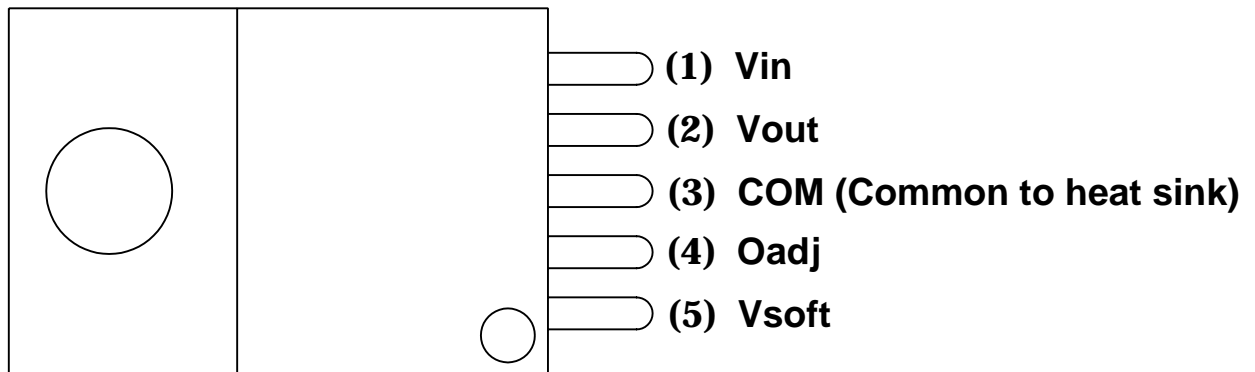

(TO-220-5)

\* All specs and applications shown above subject to change without prior notice.

Fig.1 Test Circuit

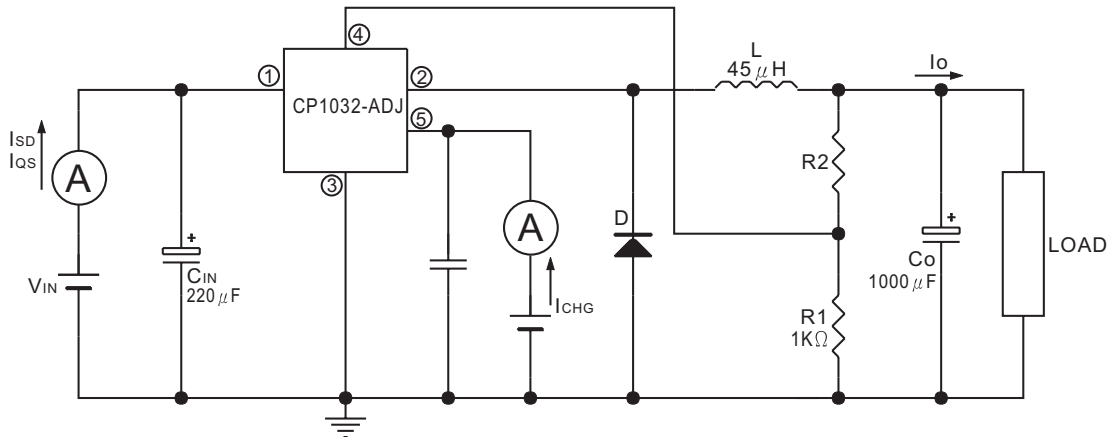

5 terminal	Vo output
LOW	OFF
HIGH	ON
OPEN	ON

Fig.2 Test Circuit

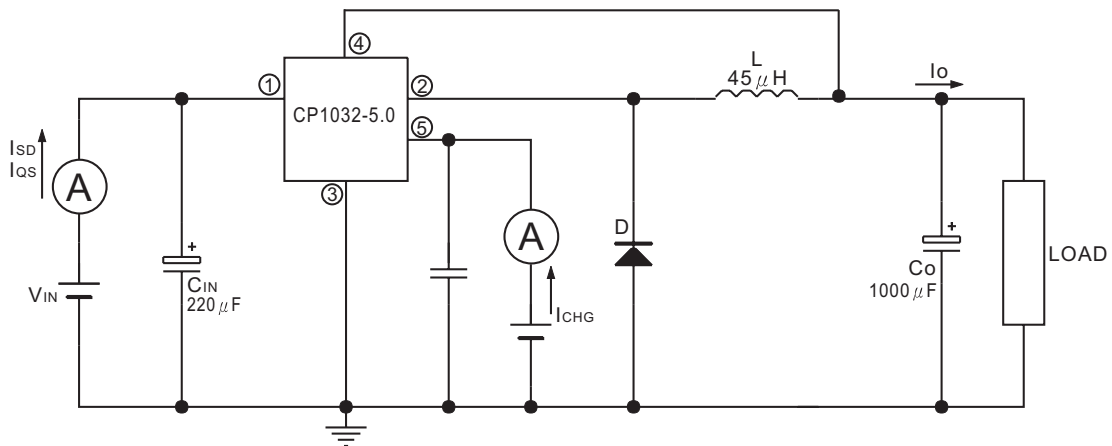

5 terminal	Vo output
LOW	OFF
HIGH	ON
OPEN	ON

\* All specs and applications shown above subject to change without prior notice.

**Fig.3 Power Dissipation vs. Ambient Temperature**

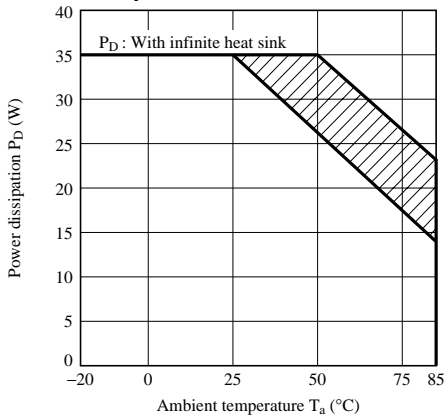

Note) Oblique line portion: Overheat protection may operate in this area.

**Fig.4 Overcurrent Protection Characteristics (Typical Value)**

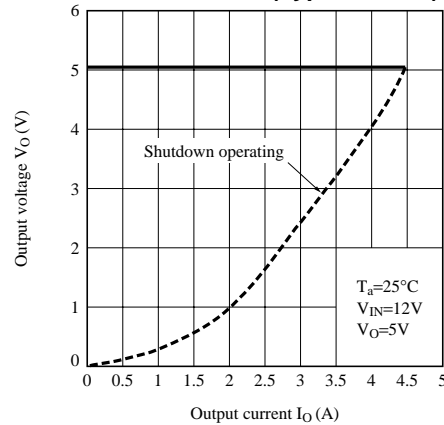

**Fig.5 Efficiency vs. Input Voltage**

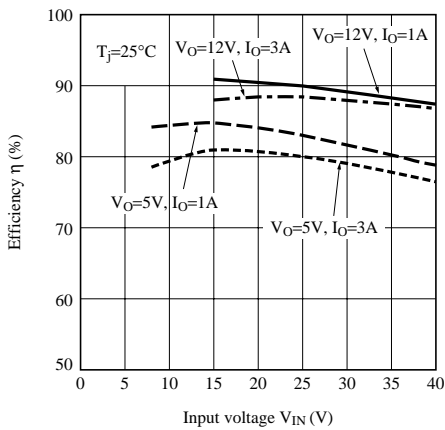

**Fig.6 Switching Current vs. Output Saturation Voltage**

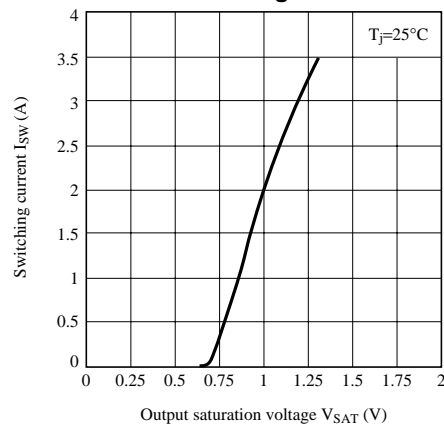

**Fig.7 Operating Dissipation Current vs. Input Voltage**

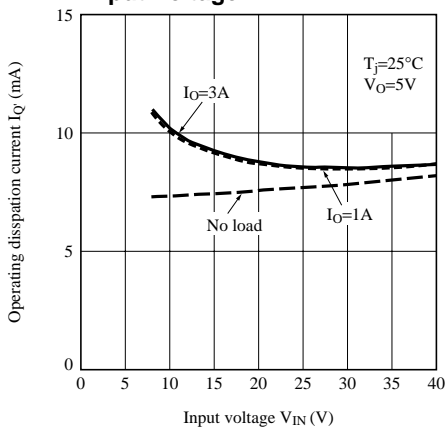

**Fig.8 Reference Voltage Fluctuation vs. Junction Temperature**

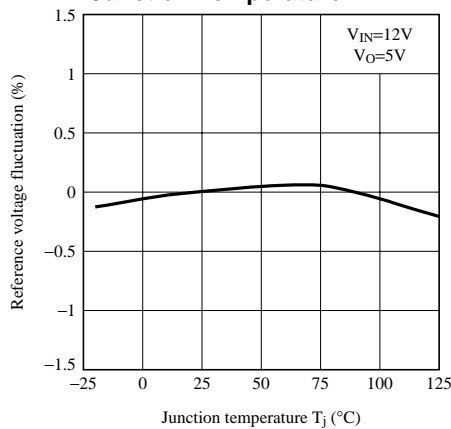

\* All specs and applications shown above subject to change without prior notice.

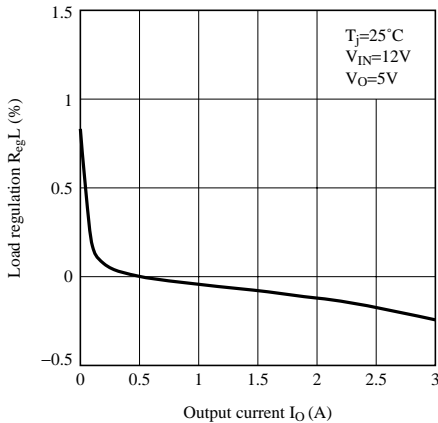
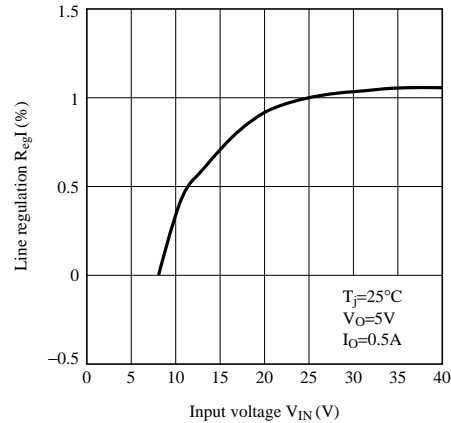
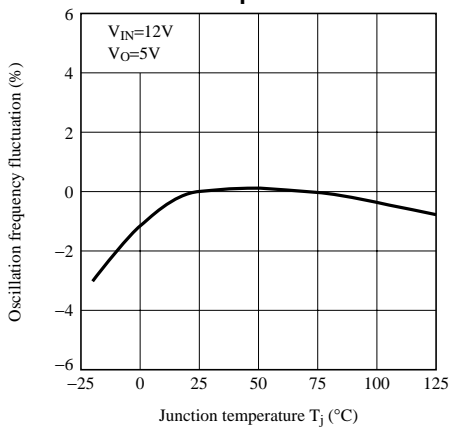
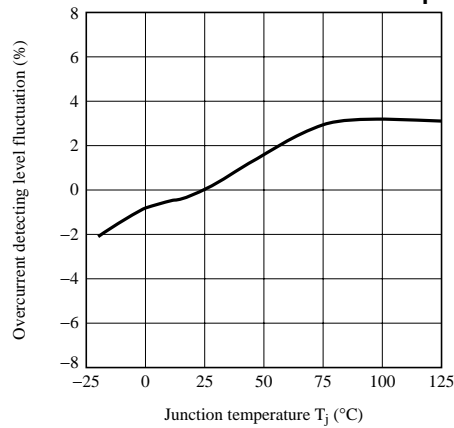
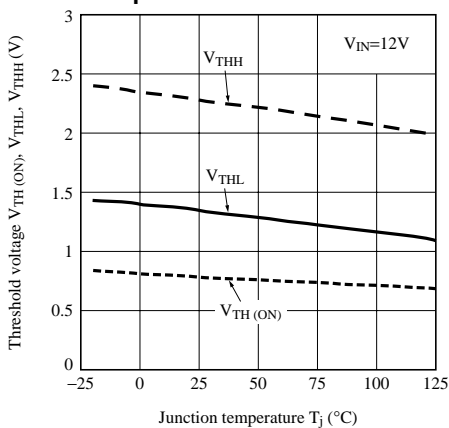
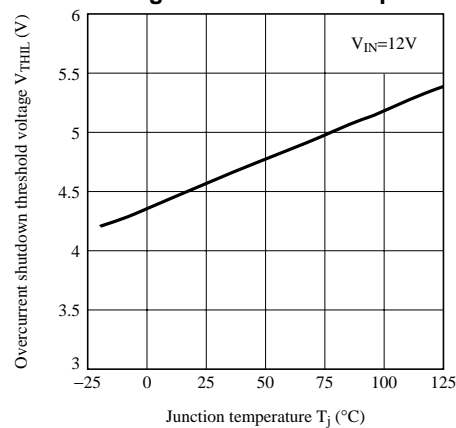
**Fig.9 Load Regulation vs. Output Current**

**Fig.10 Line Regulation vs. Input Voltage**

**Fig.11 Oscillation Frequency Fluctuation vs. Junction Temperature**

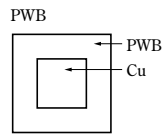
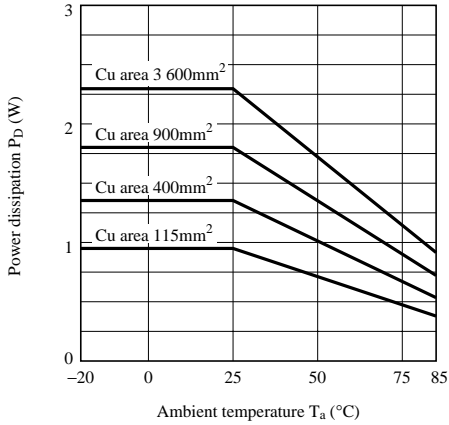
**Fig.12 Overcurrent Detecting Level Fluctuation vs. Junction Temperature**

**Fig.13 On Threshold Voltage vs. Junction Temperature**

**Fig.14 Overcurrent Shutdown Threshold Voltage vs. Junction Temperature**

\* All specs and applications shown above subject to change without prior notice.

**Fig.15 Power Dissipation vs. Ambient Temperature (Typical Value)**



Material : Glass-cloth epoxy resin  
 Size : 60×60×1.6mm  
 Cu thickness : 65μm

**Fig.16 Block Diagram**

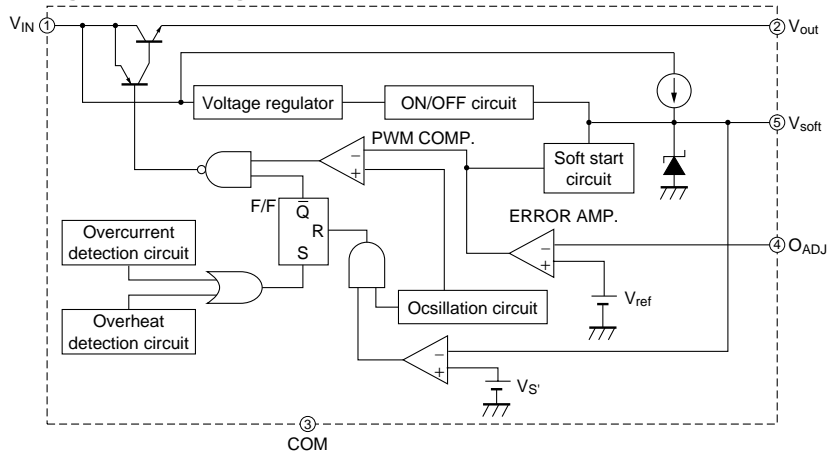

\* All specs and applications shown above subject to change without prior notice.



Fig.17 Step Down Type Circuit Diagram

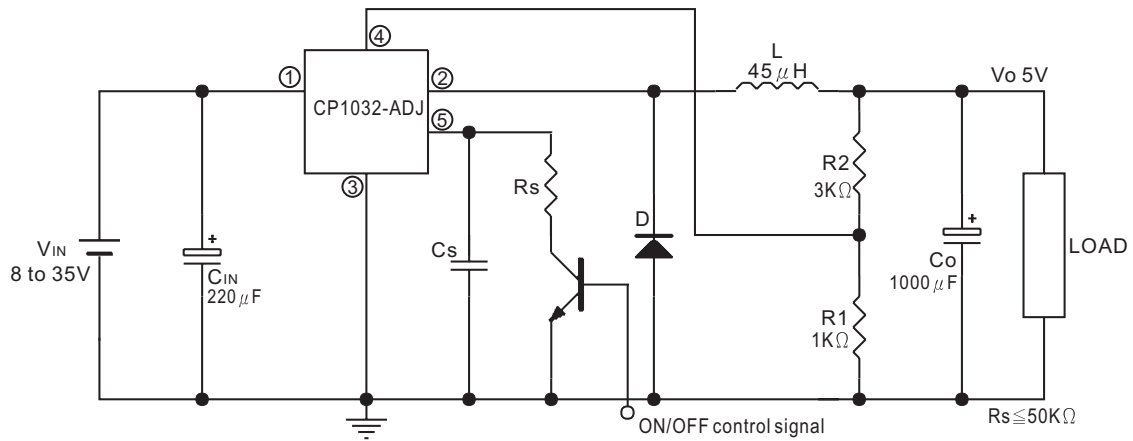
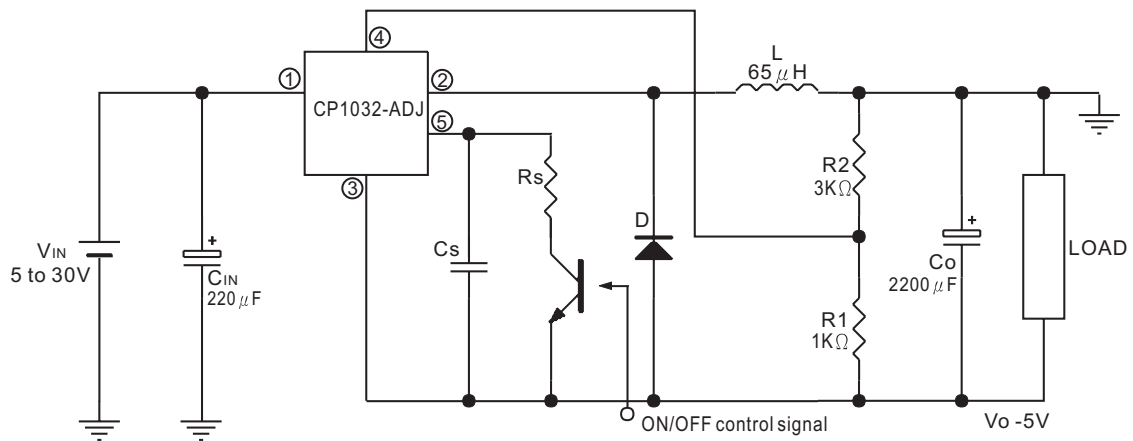

Fig.18 Polarity Inversion Type Circuit Diagram



\* All specs and applications shown above subject to change without prior notice.

Fig.19 Step Down Type Circuit Diagram

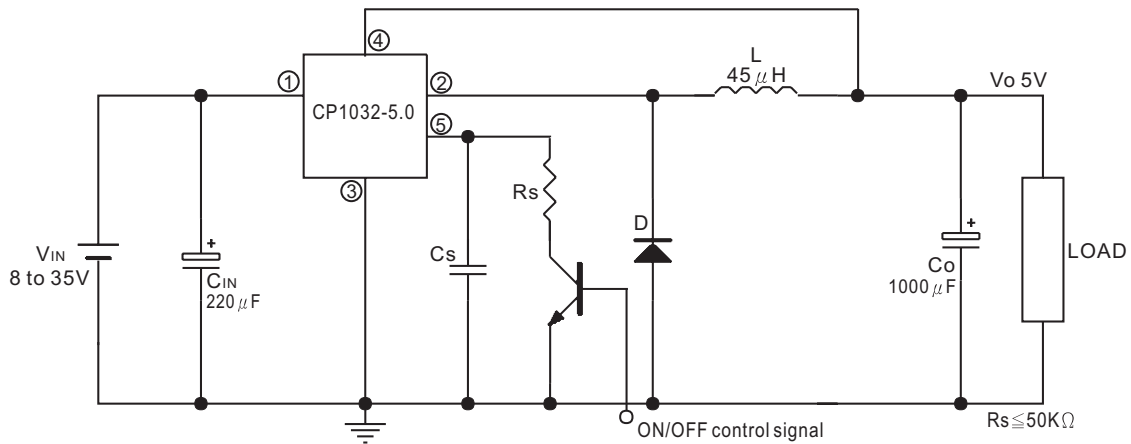
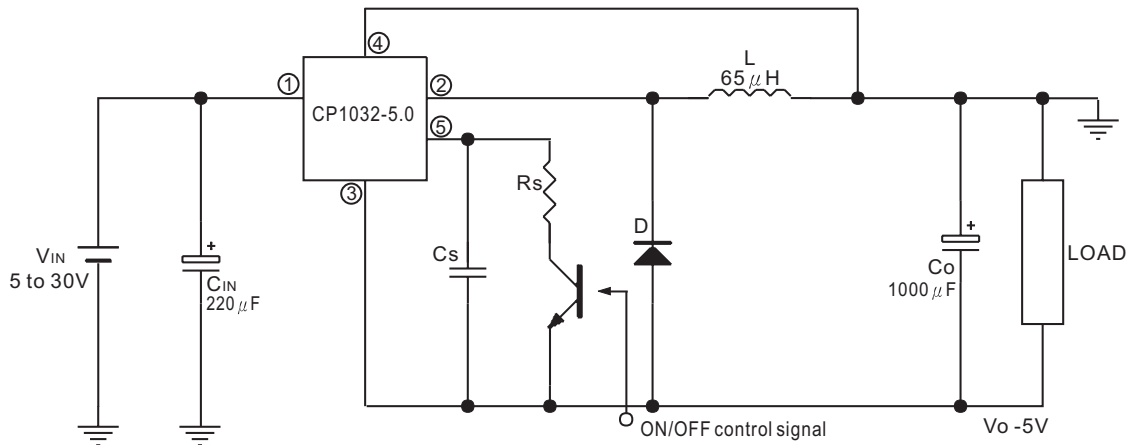

Fig.20 Polarity Inversion Type Circuit Diagram



\* All specs and applications shown above subject to change without prior notice.

■ **Physical Dimensions** inch(millimeters)

(TO-263-5)

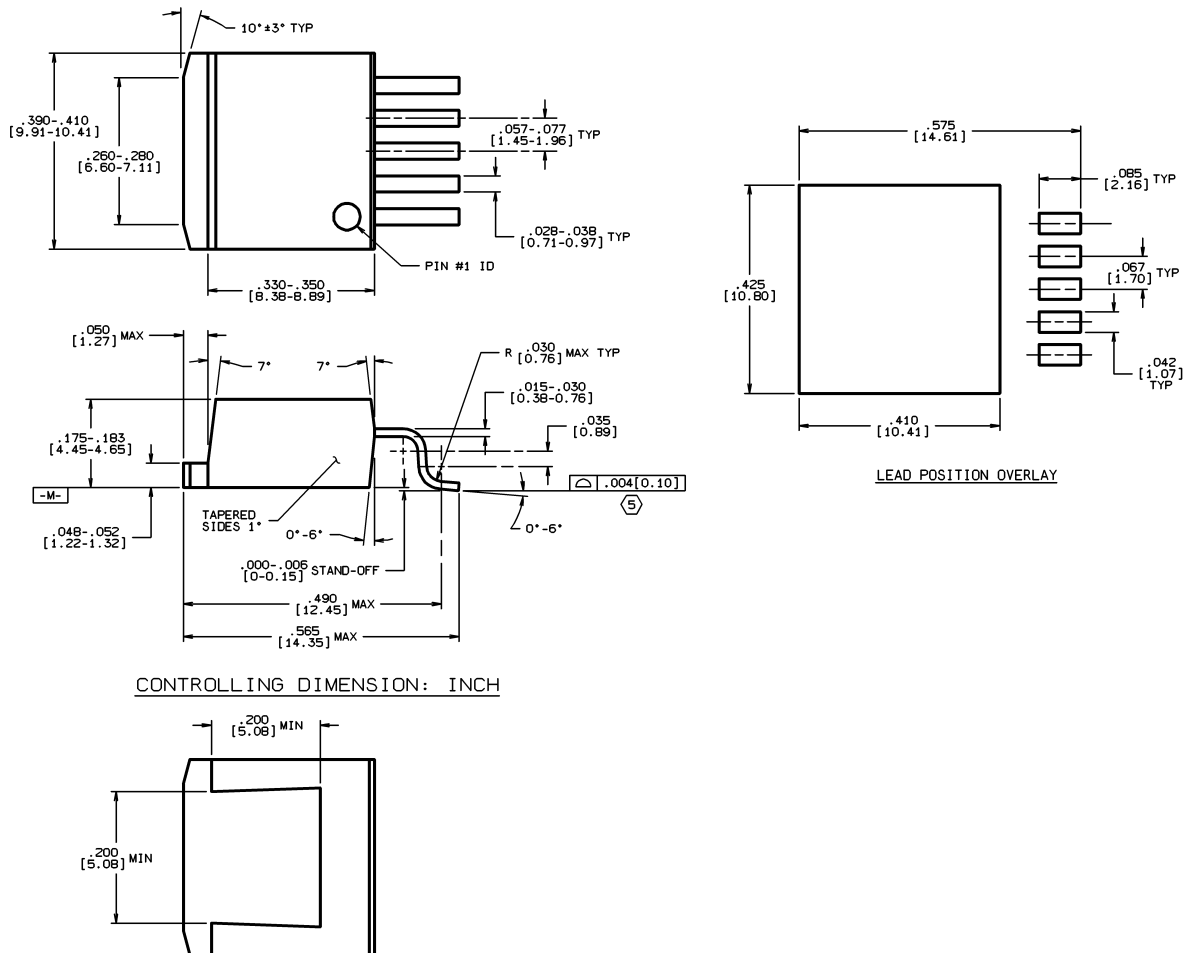

\* All specs and applications shown above subject to change without prior notice.

(TO-220-5)

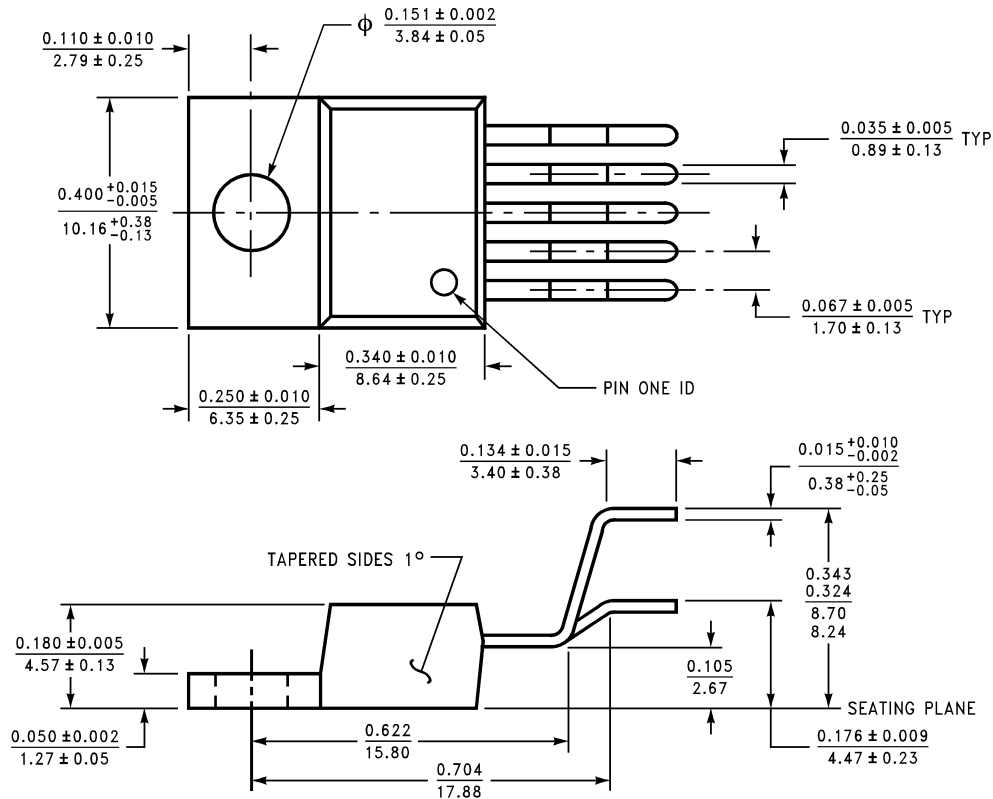

\* All specs and applications shown above subject to change without prior notice.