

DESCRIPTION

The LX1704 family represents a new generation of a fully integrated audio stereo Class-D amplifier from Microsemi. This CMOS stereo Class-D amplifier series is optimized for low voltage, low power operation and minimum system cost. The products are ideal for use in battery powered applications where low power consumption is desirable such as: portable speakers, DVDs, PMP, and other low power systems.

The LX1704 family provides very low quiescent current consumption through the use of a proprietary output modulation scheme. This technology enables filterless operation in many applications. The part features on board, low $R_{ds(on)}$, complementary output MOSFET's that reduces the need for external components.

The LX1704 is offered in a small footprint, low profile, 4mm x 4mm 16-pin MLPQ.

IMPORTANT: For the most current data, consult MICROSEMI's website: <http://www.microsemi.com>

KEY FEATURES

- No Output Filter Required
- Low EMI Design
- Low Quiescent Current: 4mA
- Low Shutdown Current: 1 μ A
- Wide Supply Voltage Range: 2.5 - 5.5 Volt
- 2W Output Power into 4 Ω Load with THD<1% @ 5.0V
- THD+N as Low as 0.1%
- Small Form Factor...16 pin MLP Package Only 4 x 4mm
- Built-in Clock Frequency
- Built-in Feedback Loop, Keep High Audio Fidelity
- Fixed 20dB Gain
- Full 20 - 20kHz Audio Bandwidth
- Shut-down Function
- Internal Thermal Shutdown
- High Efficiency: over 85% through Modulation Scheme and Class-D Operation
- Built-in De-Pop Circuit

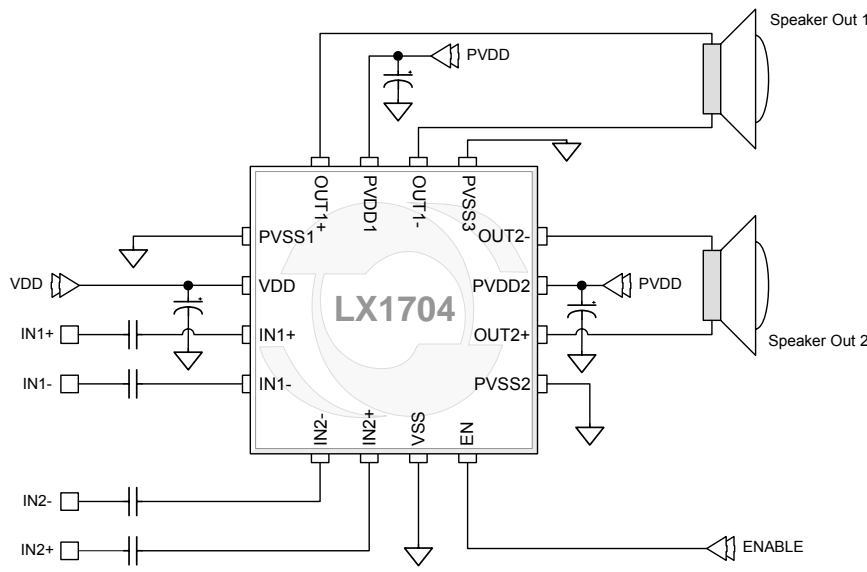
PRODUCT HIGHLIGHT

APPLICATIONS

- Portable Speakers
- Portable DVD
- PMP / PMC
- Notebook PC

PACKAGE ORDER INFO

T_A (°C)	LQ Plastic MLPQ 4mm x 4mm 16-Pin RoHS Compliant / Pb-free
0 to 70	LX1704CLQ

Note: Available in Tape & Reel. Append the letters "TR" to the part number. (i.e. LX1704CLQ-TR)

ABSOLUTE MAXIMUM RATINGS

Positive Supply Voltage (VDD, PVDD).....	-0.3 to 6.5V
Analog Input Voltage (IN1+, IN1-, IN2+, IN2-).....	-0.3 to VDD + 0.3V
Digital Input Voltage(EN, MUTE)	-0.3 to VDD + 0.3V
Operating Temperature Range (T _A)	0°C to +70°C
Maximum Operating Junction Temperature (T _J)	150°C
Storage Temperature Range.....	-65°C to 150°C
Package Peak Temp. for Solder Reflow (40 seconds maximum exposure) ...	260°C (+0 -5)

Note: Exceeding these ratings could cause damage to the device. All voltages are with respect to Ground. Currents are positive into, negative out of specified terminal.

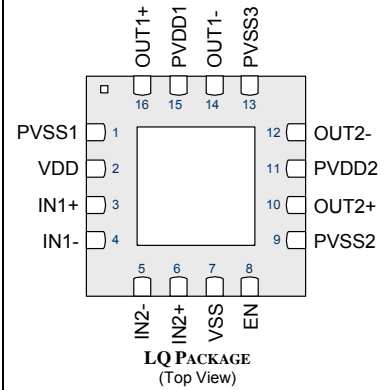
PACKAGE PIN OUT

RoHS / Pb-free 100% matte Tin Lead Finish

THERMAL DATA

LQ Plastic MLPQ 16-Pin 4mm x 4mm

THERMAL RESISTANCE-JUNCTION TO AMBIENT, θ_{JA}

24.6°C/W

Junction Temperature Calculation: $T_J = T_A + (P_D \times \theta_{JA})$.

The θ_{JA} numbers are guidelines for the thermal performance of the device/pc-board system. All of the above assume no ambient airflow.

FUNCTIONAL PIN DESCRIPTION

Name	Description
VSS	Negative Supply to Analog Stage (ground)
IN1-	Negative Audio Input Channel 1
IN1+	Positive Audio Input Channel 1
EN	Enable Pin, Active High
IN2-	Negative Audio Input Channel 2
IN2+	Positive Audio Input Channel 2
VDD	Analog Positive Power Supply
PVSS1 PVSS2 PVSS3	Negative Supply to Negative Output Stage (ground) for Channel1
OUT1+	Positive Audio (PWM) Output for Channel 1
PVDD1 & PVDD2	Positive supply to Positive Output Stage for Channel 1
OUT1-	Negative Audio (PWM) Output for Channel 1
OUT2+	Positive Audio (PWM) Output Channel 2
OUT2-	Negative Audio (PWM) Output Channel 2

SYSTEM CHARACTERISTICS

The following specifications apply over the operating ambient temperature $0 \leq T_A \leq 70^\circ\text{C}$ except where otherwise noted and the following test conditions: PVDD = VDD = 5.0V, PVSS = VSS = 0V, RL = 4Ω

Parameter	Symbol	Test Conditions	LX1704			Units
			Min	Typ	Max	
Supply Current: Quiescent	I _{QQ}	No Load		2.5	5	mA
Supply Current: Shutdown Mode	I _{QQSD}	Disable Pin Active			1	μA
Output Power @ 4 Ohms	P _O	VDD = PVDD = 5V, Fin = 1kHz	THD+N = 1%	2.4		W
			THD+N = 10%	3.3		
		VDD = PVDD = 3.3V, Fin = 1kHz	THD+N = 1%	0.9		
			THD+N = 10%	1.2		
Power Efficiency	H	VDD = PVDD = 5V, Fin = 1kHz		85		%
Total Harmonic Distortion @ 50% of Maxim Power	THD_N	VDD = PVDD = 5V, Fin = 1kHz, RL = 4Ω		0.1		%
Signal To Noise Ratio	SNR	VDD = PVDD = 5V, F = 1kHz, P _O = 1W, A-weighted		90		dB
Output Noise Floor	V _N	Input Grounded A-weighted 20 to 20kHz		100		μV _{RMS}
Frequency Response Lower Corner Frequency	F _{LO}	3dB relative to 1kHz	20		20K	Hz
Frequency Response		VDD = PVDD = 2.5 to 5.5V, RL = 4Ω, P _O = 200mW @ 20 to 80kHz, Filter less			3	dB
Power Supply Rejection Ratio	PSRR	Input Referred, VDD = PVDD = 2.5V to 5.5V	55	60		dB
Common Mode Rejection Ratio	CMRR	VDD = PVDD = 2.5V to 5.5V	55	60		dB
Gain	G _{sys}			20		dB

ELECTRICAL CHARACTERISTICS

The following specifications apply over the operating ambient temperature $0 \leq T_A \leq 70^\circ\text{C}$ except where otherwise noted and the following test conditions: PVDD = VDD = 5.0V, PVSS = VSS = 0V, RL = 4Ω

Parameter	Symbol	Test Conditions	LX1704			Units
			Min	Typ	Max	
Supply Voltage	VDD PVDD		2.5		5.5	V
Oscillator Frequency	f _{SW}	VDD = PVDD = 2.5 to 5.5V		200		kHz
Supply Current: Quiescent	I _{QQ}	No Load	VDD = PVDD = 5V	2.5	5	mA
			VDD = PVDD = 3.3V	2	4	
Supply Current: Shutdown Mode	I _{QQSD}	Disable Pin Active			1	μA
Power Supply Rejection Ratio	PSRR	VDD = PVDD = 2.5V to 5.5V	55	60		dB
Input Resistance	R _{IN}	VDD = PVDD = 2.5V to 5.5V Single Ended		18		KΩ
Output DC Offset	V _{OFF}	Input Shorted to GND	-50		+50	mV
Static Drain-to-Source ON-Resistance	RDSON	VDD = PVDD = 5V	P Channel	350		mΩ
			N Channel	350		
		VDD = PVDD = 3.3V	P Channel	470		
			N Channel	470		
		VDD = PVDD = 2.5V	P Channel		600	
			N Channel		600	
Stage Gain	G _H	VDD = PVDD = 2.5V to 5.5V	9	10	11	V/V
Thermal Indicator Junction	T _J			150		°C
Under Voltage Threshold Level	V _{DD}		1.8	2.0	2.2	V
Enable Threshold	EN		2.10	2.25	2.40	V

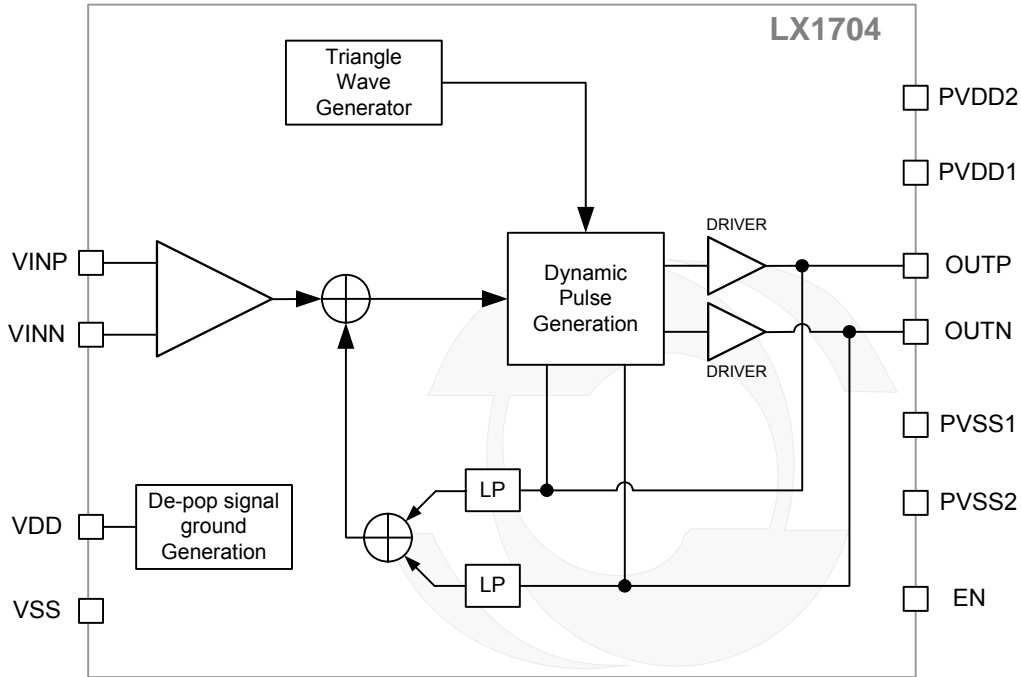
SIMPLIFIED BLOCK DIAGRAM

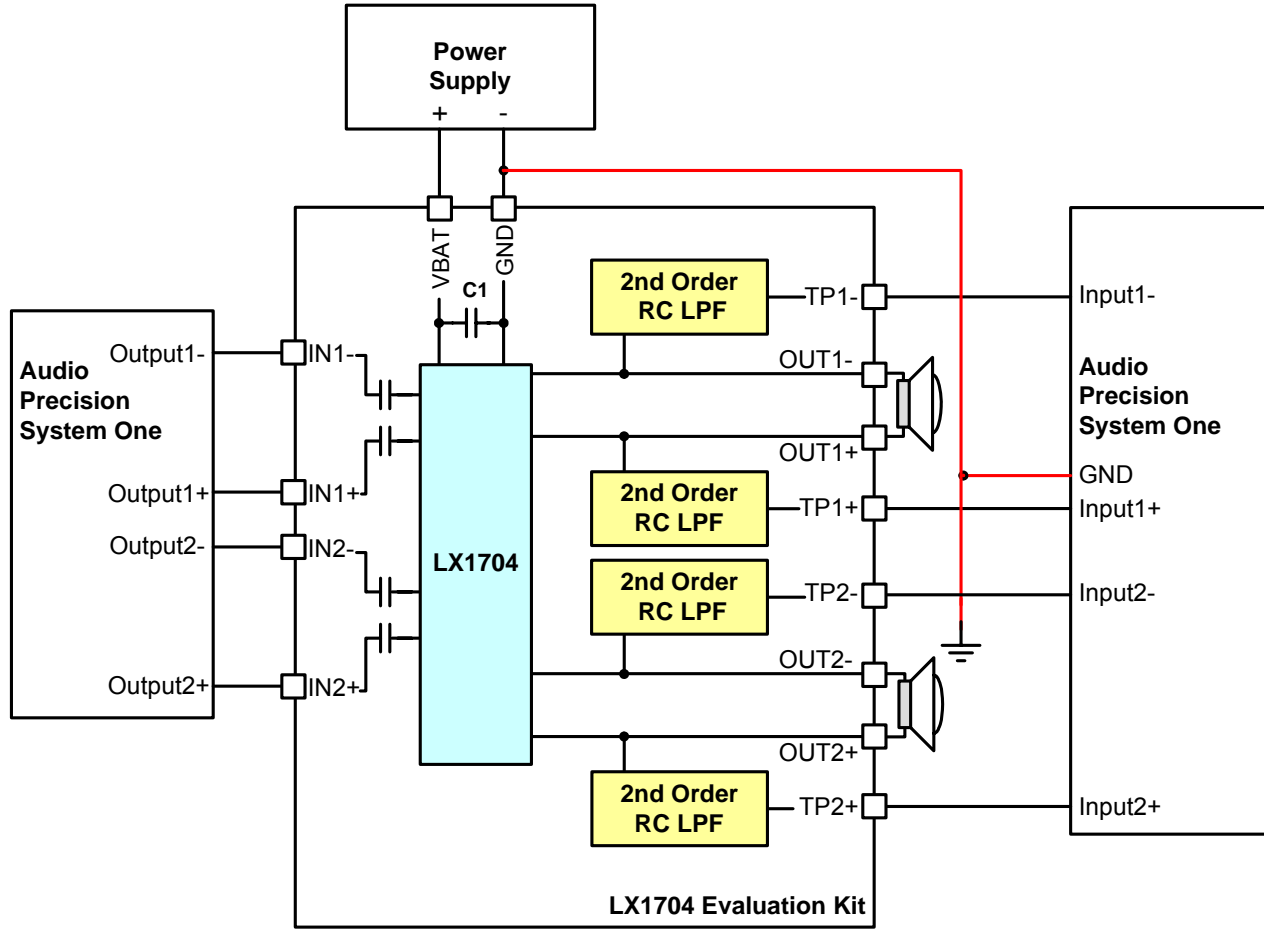
Figure 1 – LX1704 Simplified Block Diagram (Half Circuit)

SYSTEM TEST SETUP

Figure 2 – Typical Evaluation Test Setup Circuit
Default Settings:

Equipments: Audio Precision SYSTEM 1

Oscilloscope,

Power Supply ~ +5V;

Supply Voltage: 2.5V / 3.3V / 5.0V 3 corner voltages

On-Board passive LPF: 40kHz cut off frequency (-6dB)

AP settings: 10Hz ~ 22KHz BPF

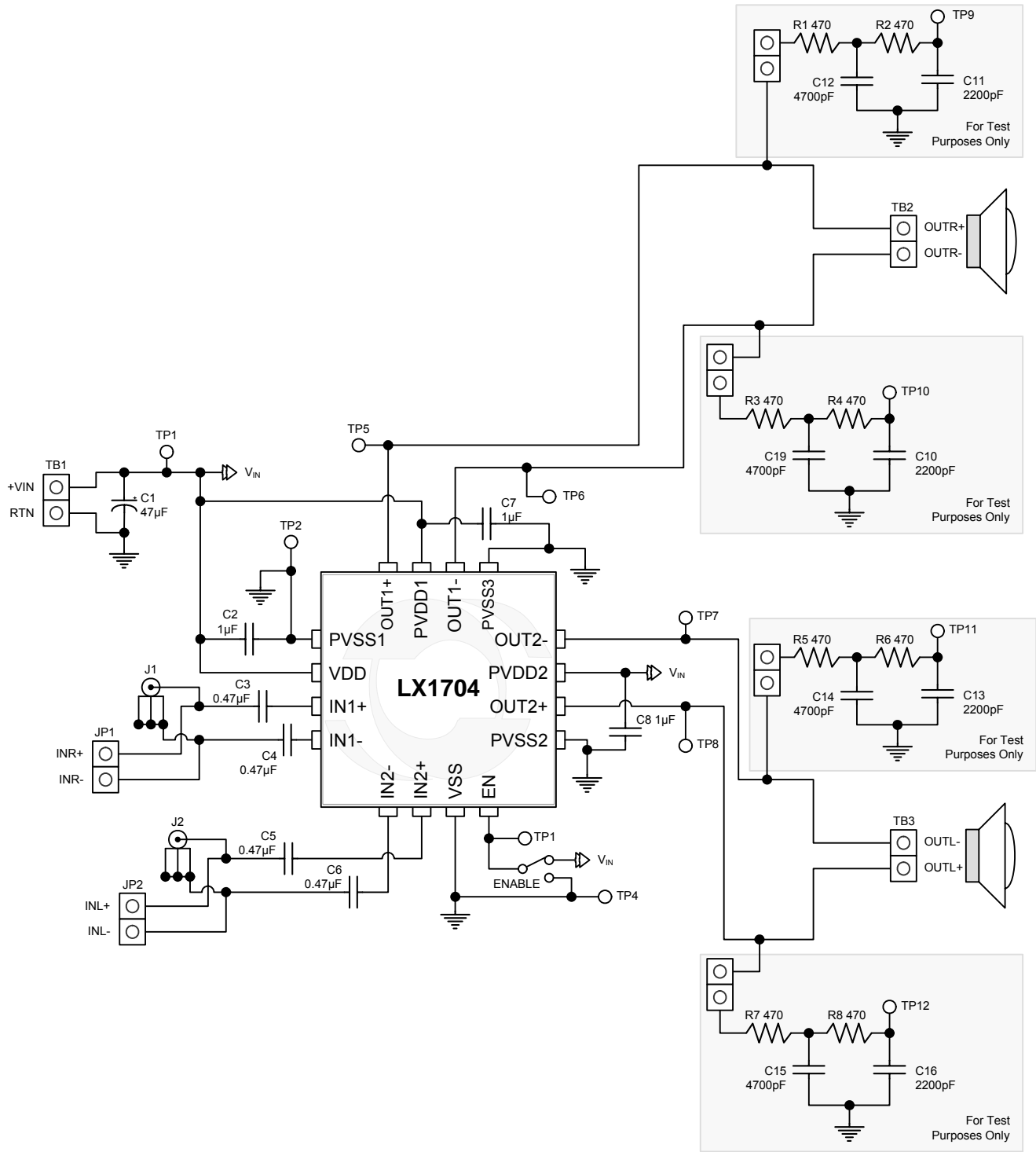
APPLICATION CIRCUITS

Figure 3 – Typical LX1704 Application

FUNCTIONAL DESCRIPTION**GENERAL DESCRIPTION**

The LX1704 is a filterless, low-EMI, class-D audio power amplifier. It offers high performance (THD+N is just 0.1% @ 2W), high efficiency (>85% @ 1.2W), and best in class EMI radiation (just 20dB μ V/m). The internal signal path is completely differential to minimize common-mode noise pickup. The inputs may be driven single-ended or differentially and they may be direct or AC coupled. The LX1704 may be operated with just a single decoupling capacitor.

FILTERLESS 3-LEVEL CLASS-D MODULATION

The LX1704 output stage is configured as a full H-bridge push-pull driver. The speaker must be driven differentially from the OUTP and OUTN pins. Each side of the speaker is driven by a 200KHz switching signal that transitions between V_{DD} and GND. With zero input voltage, the duty cycle at each output is around 50% and the signals are in-phase with each other. In this case, there is basically no differential voltage across the speaker. When the input signal goes positive, the duty cycle at OUTP increases above 50% and the duty cycle at OUTN decreases below 50%. This causes a net positive current to flow into the speaker. A negative input voltage causes the OUTN duty cycle to increase and the OUTP duty cycle to decrease which causes a net negative current to flow into the speaker. The differential voltage across the speaker has a fundamental frequency of twice the 200KHz switching frequency. The speaker itself serves as the low pass filter which then recreates the audio signal. This type of modulation can be described as driving $+V_{DD}$, $-V_{DD}$, and 0V across the speaker which is why it is referred to as 3-Level modulation.

Classical, 2-Level modulation drives either $+V_{DD}$ or $-V_{DD}$ across the speaker at all times. This scheme requires an L-C filter between the amplifier's outputs and the speaker in order to keep the output current low.

LOW-EMI OUTPUT STAGE WITH SLEW RATE LIMITING AND ACTIVE OVERSHOOT CLAMPING

With 3-Level modulation, the carrier frequency drives a full amplitude common-mode signal to the speaker wires. This can cause high EMI radiation. One way to combat this would be to filter the outputs with LC filters or ferrite beads located close to the amplifier. In the LX1704, the output stage has been carefully designed to minimize EMI radiation so that these types of filters are not required. Slew rate limiting is used to keep the outputs from switching too quickly. Active overshoot clamping is used to minimize the inductive overshoot which occurs at each transition. These two techniques allow the LX1704 to easily meet FCC standards for radiated emissions when driving up to 3 meters of speaker wire.

DIFFERENTIAL SIGNAL PATH, WIDE DYNAMIC RANGE, AND BUILT-IN THERMAL OVERLOAD PROTECTION

The fully differential signal path uses Pulse Width Modulation and multiple feedback loops to provide high performance and low distortion. This is all fully-integrated to eliminate the need for any external feedback components or filters. The gain is fixed by internal resistors at 20dB. The differential signal path and internal voltage boosters allow for wide dynamic range. In fact, the LX1704 can be operated from supplies as low as 2.5V and as high as 5.5V. The output power will be limited by the available supply voltage. An internal thermal sensing circuit shuts down the outputs when the junction temperature exceeds about 150°C to provide thermal overload protection.

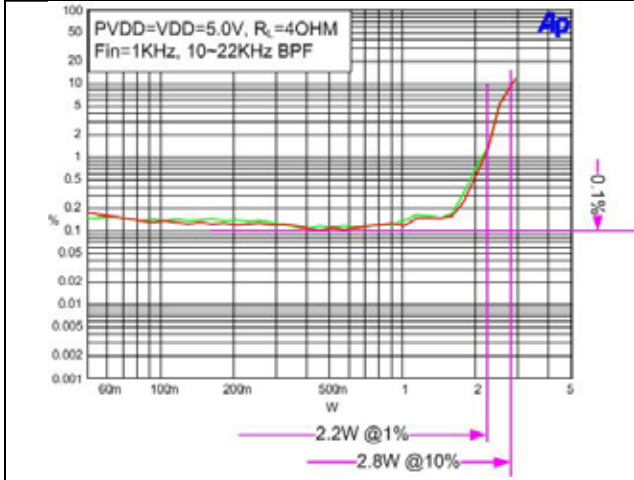
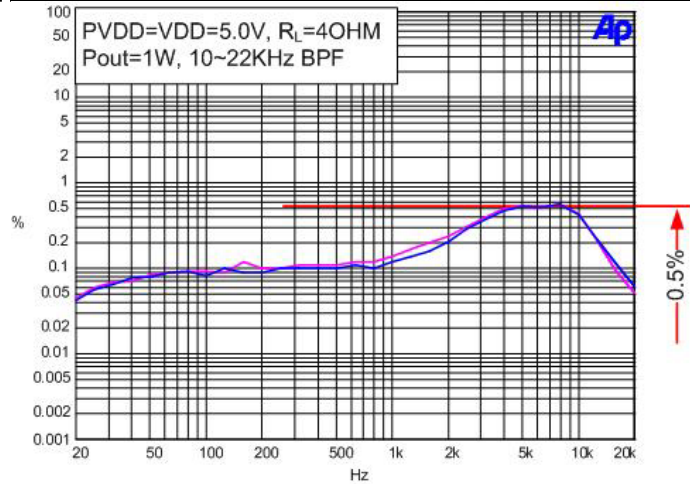
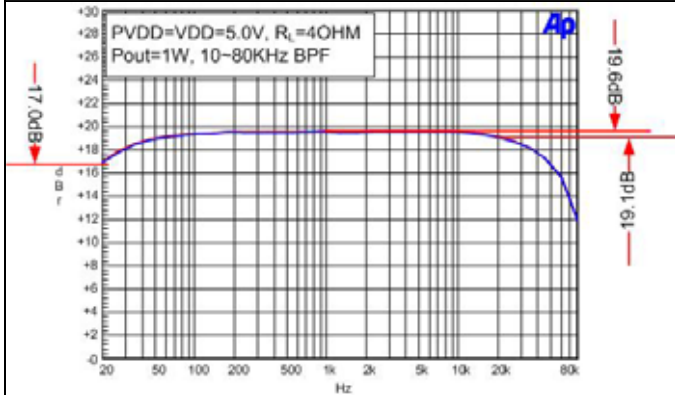
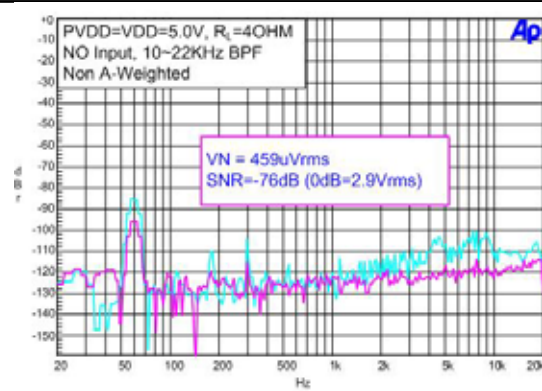
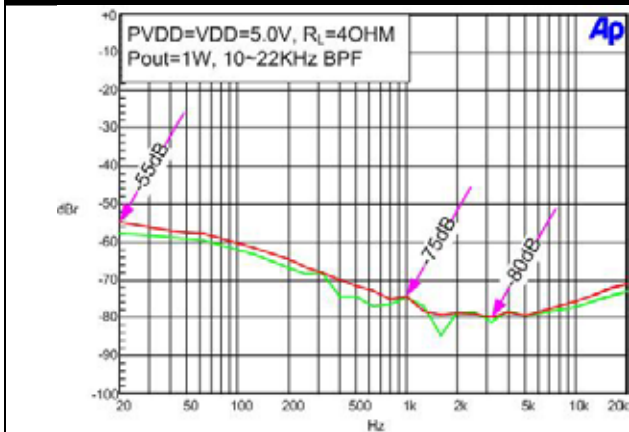
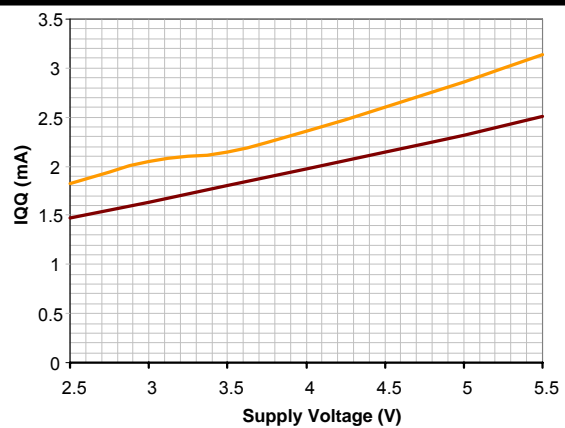
THD+N VS. POWER

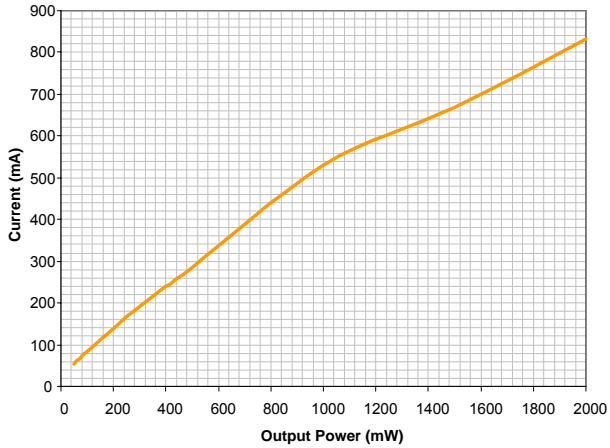
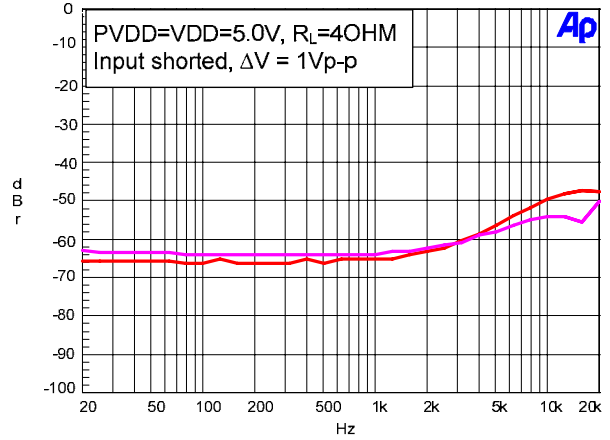
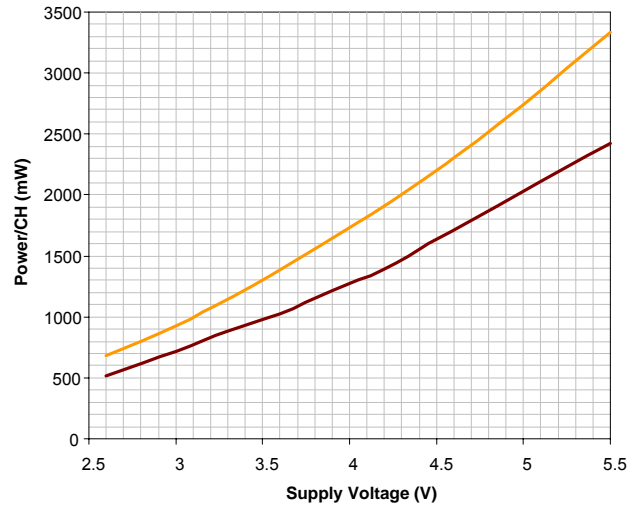
THD+N VS. FREQUENCY

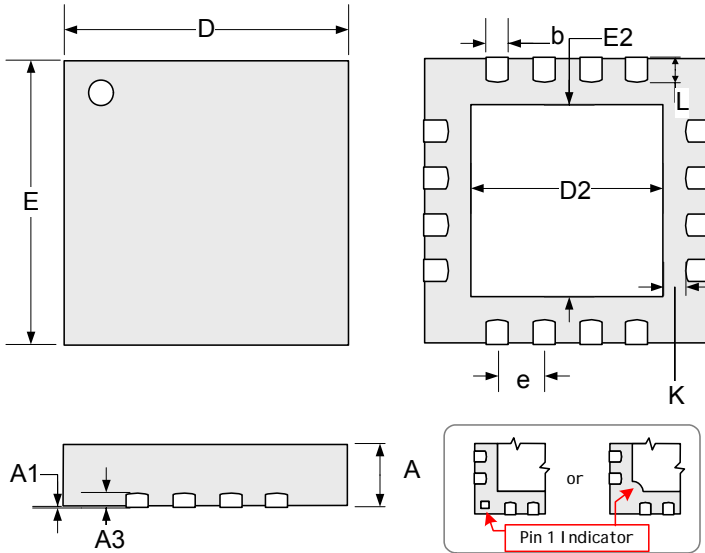
GAIN RESPONSE

NOISE FLOOR

CHANNEL CROSSTALK

IQQ VS. SUPPLY VOLTAGE

POWER SUPPLY VS OUTPUT POWER

PSRR

POWER VS SUPPLY VOLTAGE

PACKAGE DIMENSIONS
LQ
16-Pin MLPQ Plastic (4mm x 4mm EP / 114x114Cu Exposed Pad)

Dim	MILLIMETERS		INCHES	
	MIN	MAX	MIN	MAX
A	0.80	1.00	0.031	0.039
A1	0	0.05	0	0.002
A3	0.18	0.30	0.007	0.012
b	0.23	0.38	0.009	0.015
D	4.00 BSC		0.157 BSC	
E	4.00 BSC		0.157 BSC	
e	0.65 BSC		0.026 BSC	
D2	2.55	2.80	0.100	0.110
E2	2.55	2.80	0.100	0.110
K	0.20	-	0.008	-
L	0.30	0.50	0.012	0.020

Note:

1. Dimensions do not include mold flash or protrusions; these shall not exceed 0.155mm(.006") on any side. Lead dimension shall not include solder coverage.



Microsemi[®]

LX1704

2W Filter less Stereo Class-D Amplifier

PRODUCTION DATA SHEET

NOTES

PRODUCTION DATA – Information contained in this document is proprietary to Microsemi and is current as of publication date. This document may not be modified in any way without the express written consent of Microsemi. Product processing does not necessarily include testing of all parameters. Microsemi reserves the right to change the configuration and performance of the product and to discontinue product at any time.