

SWITCHING REGULATOR POWER OUTPUT STAGES

DESCRIPTION

The SM625/626/627 series of Power Output Stages are especially designed to be driven with standard PWM integrated circuits to form an efficient switching power supply. The SM625, SM626 and SM627 are optimized for non-isolated Buck and Buck-Boost application. The hybrid circuit construction utilizes thick film resistors on a beryllia substrate for maximum thermal conductivity and resultant low thermal impedance. All of the active elements in the hybrid are fully passivated.

FEATURES

- Equivalent to the Unitrode PIC 625, 626, 627
- 15A current capability
- Designed and characterized for switching regulator applications such as Buck, Boost, and Buck-Boost type
- Cost saving design reduces size, improves efficiency, reduces noise and RFI
- High operating frequency (to > 100KHz) results in smaller inductor-capacitor filter and improved power supply response time
- High operating efficiency at 7A typical performance -
Rise and fall time < 300ns
Efficiency > 85%
- Electrically isolated, 4-pin, TO-66 hermetic case

HIGH RELIABILITY FEATURES

- ◆ Available with high reliability processing

FUNCTIONAL DIAGRAM

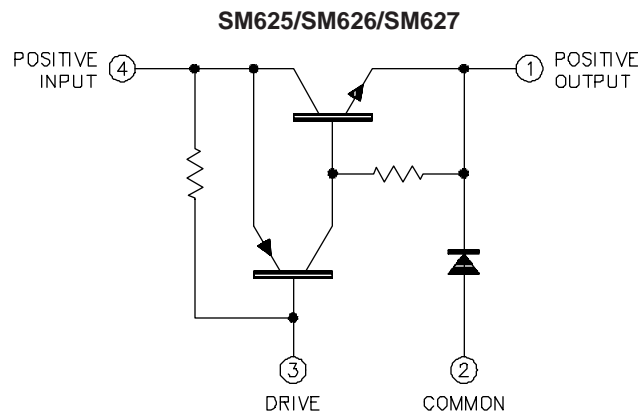

ABSOLUTE MAXIMUM RATINGS (Note 1)

	SM625	SM626	SM627
Input Voltage, V_{4-2}	60V	80V	100V
Output Voltage, V_{1-2}	60V	80V	100V
Drive Input Reverse Voltage, V_{3-4}	5V	5V	5V
Output Current, I_1	15A	15A	15A
Drive Current, I_3	-0.4A	-0.4A	-0.4A

Thermal Resistance	
Power Switch, θ_{j-c}	4.0°C/W
Commutating Diode	4.0°C/W
Case to Ambient, θ_{c-a}	60.0°C/W

Operating Junction Temperature	
Hermetic (R Package)	150°C
Storage Temperature Range	-65°C to 150°C
Lead Temperature (Soldering, 10 Seconds)	300°C

Note 1. Exceeding these ratings could cause damage to the device.

THERMAL DATA

R Package:

Thermal Resistance-Junction to Case, θ_{j-c}	4.0°C/W
Thermal Resistance-Junction to Ambient, θ_{j-a}	40°C/W

Note A. Junction Temperature Calculation: $T_j = T_a + (P_D \times \theta_{j-a})$.

Note B. The above numbers for θ_{j-c} are maximums for the limiting thermal resistance of the package in a standard mounting configuration. The θ_{j-a} numbers are meant to be guidelines for the thermal performance of the device/pc-board system. All of the above assume no ambient airflow.

RECOMMENDED OPERATING CONDITIONS (Note 2)

	SM625	SM626	SM627
Input Voltage, V_{4-2}	50V	70V	90V
Output Voltage, V_{1-2}	50V	70V	90V
Drive Input Reverse Voltage, V_{3-4}	4V	4V	4V
Output Current, I_1	13A	13A	13A
Drive Current, I_3	-0.3A	-0.3A	-0.3A

Operating Ambient Temperature Range	
SM6XXR	0°C to 70°C
SM6XXHRR	-55°C to 125°C

Note 2. Range over which the device is functional.

ELECTRICAL CHARACTERISTICS

(Unless otherwise specified, these specifications apply for the operating ambient temperature of $T_a = 25^\circ\text{C}$. Low duty cycle pulse testing techniques are used which maintains junction and case temperatures equal to the ambient temperature.)

Parameter	Test Conditions	SG625/626/627			Units
		Min.	Typ.	Max.	
On-State Voltage (Note 3)	$I_4 = 7\text{A}(-7\text{A}), I_3 = -30\text{mA} (30\text{mA})$		1.0	1.5	V
	$I_4 = 15\text{A}(-15\text{A}), I_3 = -30\text{mA} (30\text{mA})$		2.5	3.5	V
Diode Forward Voltage (Note 3)	$I_4 = 7\text{A}(-7\text{A})$		0.85	1.25	V
	$I_4 = 15\text{A}(-15\text{A})$		0.95	1.75	V
Off-State Current	$V_4 = \text{Rated input voltage}$		0.1	10	μA
	$V_4 = \text{Rated input voltage}, T_a = 125^\circ\text{C}$		10		μA
Diode Reverse Current	$V_1 = \text{Rated output voltage}$		1.0	10	μA
	$V_1 = \text{Rated output voltage}, T_a = 125^\circ\text{C}$		500		μA

Note 3. Pulse test: Duration = 300 μs , Duty Cycle $\leq 2\%$.

ELECTRICAL SPECIFICATIONS (continued)

Parameter	Test Conditions	SG625/626/627			Units
		Min.	Typ.	Max.	
Dynamic Characteristics (See Figures 1 & 2) (Notes 4 & 5)					
Current Delay Time			35	60	ns
Current Rise Time			65	150	ns
Voltage Rise Time			40	60	ns
Voltage Storage Time			700		ns
Voltage Fall Time			70	175	ns
Current Fall Time			175	300	ns
Efficiency (Note 5)			85		%

AC TEST CIRCUIT AND SWITCHING TIME WAVEFORMS (Note 6)

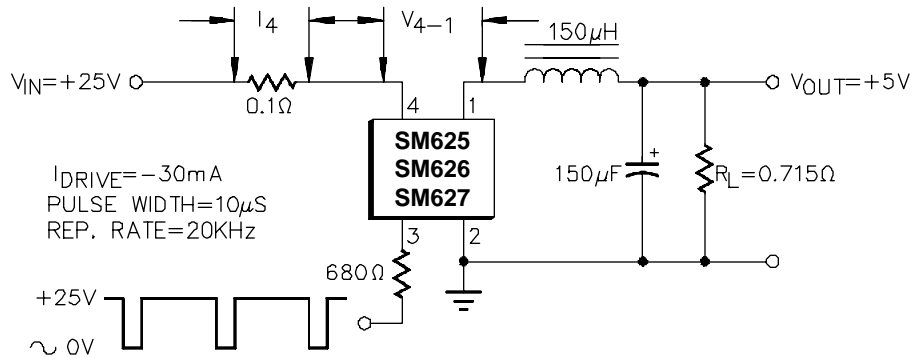

FIGURE 1 - SM625/626/627 SWITCHING SPEED CIRCUIT

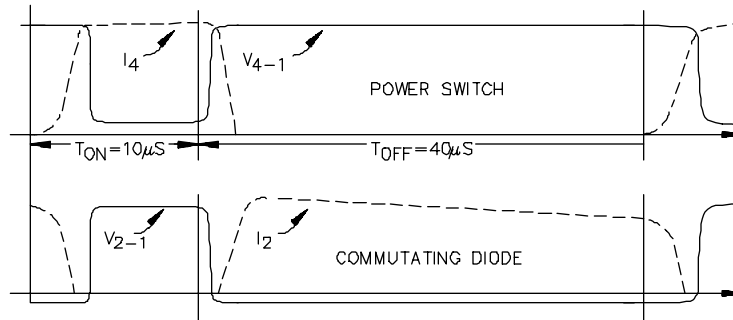

FIGURE 2 - SM625/626/627 SWITCHING WAVEFORMS

Note 4. In switching an inductive load, the current will lead the voltage on turn-on and lag the voltage on turn-off (see Figure 2). Therefore, Voltage Delay Time ($t_{DV} \cong t_{di} + t_{ri}$) and Current Storage Time ($t_{sv} \cong t_{sv} + t_{fv}$).

Note 5. The efficiency is a measure of internal power losses and is equal to Output Power divided by Input Power. The switching speed circuit of Figure 1, in which the efficiency measured, is representative of typical operating conditions for the SM600 series switching regulators.

APPLICATION CIRCUITS

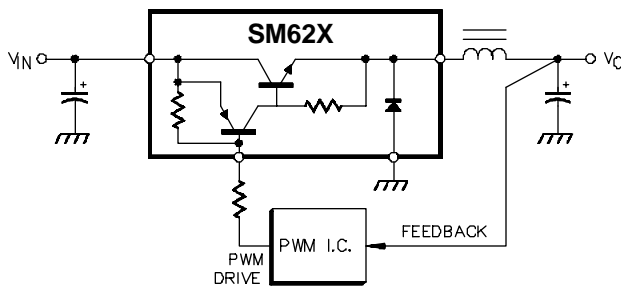

FIGURE 3 - STEP DOWN (BUCK) CONVERTER

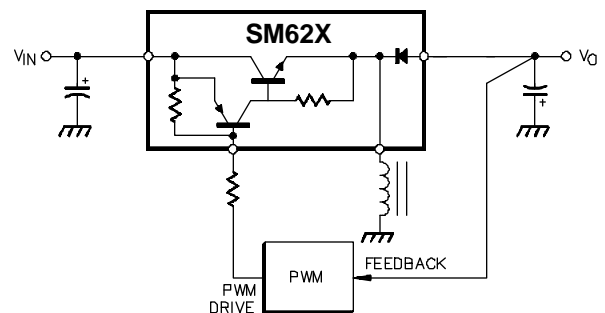

FIGURE 4 - NEGATIVE OUTPUT DOWN/UP (BUCK-BOOST) CONVERTER

CONNECTION DIAGRAMS & ORDERING INFORMATION (See Note Below)

Package	Part No.	Ambient Temperature Range	Connection Diagram
4-PIN TO-66 METAL CAN R - PACKAGE	SM625R	0°C to 70°C	
	SM625HRR	-55°C to 125°C	
	SM626R	0°C to 70°C	
	SM626HRR	-55°C to 125°C	
	SM627R	0°C to 70°C	
	SM627HRR	-55°C to 125°C	

- Note
1. All packages are viewed from the top.
 2. Case is electrically isolated.
 3. Contact factory for additional screening available.