

FEATURES

- Precision Low Voltage Monitoring down to 1.8V
- 9 Reset Threshold Options:
 - 1.58V to 4.63V
- 140ms (Min) Reset Timeout
- Watchdog Timer with 1.6s Timeout
- Manual Reset Input
- Reset Output Stages
 - Push-Pull Active-Low
 - Open-Drain Active-Low
 - Push-Pull Active-High
- Low Power Consumption (3μA)
- Guaranteed Reset Output valid to V_{CC}=1V
- Power Supply Glitch Immunity
- Specified from -40°C to +125°C
- 5-Lead SOT-23 Package

APPLICATIONS

- Microprocessor Systems
- Computers
- Controllers
- Intelligent Instruments
- Portable Equipment

GENERAL DESCRIPTION

The ADM6821-ADM6825 are supervisory circuits which monitor power supply voltage levels and code execution integrity in microprocessor-based systems. As well as providing power-on-reset signals, an on-chip watchdog timer can reset the microprocessor if it fails to strobe within a preset timeout period. A reset signal can also be asserted by means of an external push-button, through a manual reset input. The three parts feature different combinations of watchdog input, manual reset input and output stage configuration, as shown in table 1.

FUNCTIONAL BLOCK DIAGRAM

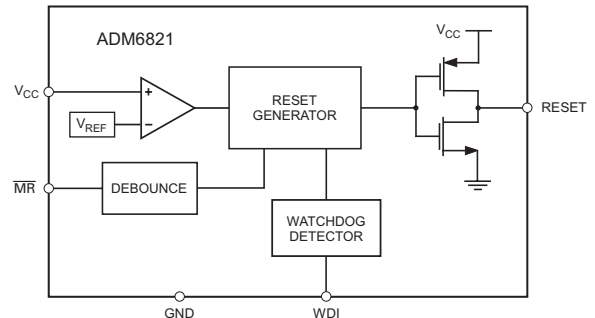

Each part is available in a choice of 9 reset threshold options ranging from 1.58V to 4.63V. The reset and watchdog timeout periods are fixed at 140ms (min) and 1.6s (typ), respectively.

The ADM6821-ADM6825 are available in 5-lead SOT-23 packages and typically consume only 3μA, making them suitable for use in low power portable applications.

Table 1. Selection Table

Part No.	Watchdog Timer	Manual Reset	Output Stage	
			RESET	RESET
ADM6821	Yes	Yes	-	Push-Pull
ADM6822	Yes	Yes	Open-Drain	-
ADM6823	Yes	Yes	Push-Pull	-
ADM6824	Yes	-	Push-Pull	Push-Pull
ADM6825	-	Yes	Push-Pull	Push-Pull

Rev. PrA

Information furnished by Analog Devices is believed to be accurate and reliable. However, no responsibility is assumed by Analog Devices for its use, nor for any infringements of patents or other rights of third parties that may result from its use. Specifications subject to change without notice. No license is granted by implication or otherwise under any patent or patent rights of Analog Devices. Trademarks and registered trademarks are the property of their respective companies.

ADM6821–ADM6825—SPECIFICATIONS

Table 2. $V_{CC}=4.5V$ to $5.5V$ for ADM682_L/M, $V_{CC}=2.7V$ to $3.6V$ for ADM682_T/S/R, $V_{CC}=2.1V$ to $2.75V$ for ADM682_Z/Y, $V_{CC}=1.53V$ to $2.0V$ for ADM682_W/V, $T_A=-40^{\circ}C$ to $+125^{\circ}C$, unless otherwise noted.

Parameter	Min	Typ	Max	Units	Test Conditions/Comments
SUPPLY					
V_{CC} Operating Voltage Range	1		5.5	V	$T_A=0^{\circ}C$ to $+70^{\circ}C$
	1.2		5.5	V	$T_A=-40^{\circ}C$ to $+125^{\circ}C$
Supply Current (WDI and \overline{MR} unconnected)		10	24	μA	$V_{CC}=5.5V$, no load, $T_A=-40^{\circ}C$ to $+85^{\circ}C$
			30	μA	$V_{CC}=5.5V$, no load, $T_A=-40^{\circ}C$ to $+125^{\circ}C$
		7	16	μA	$V_{CC}=3.6V$, no load, $T_A=-40^{\circ}C$ to $+85^{\circ}C$
			25	μA	$V_{CC}=3.6V$, no load, $T_A=-40^{\circ}C$ to $+125^{\circ}C$
		5	12	μA	$V_{CC}=3.6V$, no load, $T_A=-40^{\circ}C$ to $+85^{\circ}C$ (ADM6825 only)
			20	μA	$V_{CC}=3.6V$, no load, $T_A=-40^{\circ}C$ to $+125^{\circ}C$ (ADM6825 only)
RESET THRESHOLD VOLTAGE					
ADM682_L	4.50	4.63	4.75	V	$T_A=-40^{\circ}C$ to $+85^{\circ}C$
	4.47		4.78	V	$T_A=-40^{\circ}C$ to $+125^{\circ}C$
ADM682_M	4.25	4.38	4.50	V	$T_A=-40^{\circ}C$ to $+85^{\circ}C$
	4.22		4.53	V	$T_A=-40^{\circ}C$ to $+125^{\circ}C$
ADM682_T	3.00	3.08	3.15	V	$T_A=-40^{\circ}C$ to $+85^{\circ}C$
	2.97		3.17	V	$T_A=-40^{\circ}C$ to $+125^{\circ}C$
ADM682_S	2.85	2.93	3.00	V	$T_A=-40^{\circ}C$ to $+85^{\circ}C$
	2.83		3.02	V	$T_A=-40^{\circ}C$ to $+125^{\circ}C$
ADM682_R	2.55	2.63	2.70	V	$T_A=-40^{\circ}C$ to $+85^{\circ}C$
	2.53		2.72	V	$T_A=-40^{\circ}C$ to $+125^{\circ}C$
ADM682_Z	2.25	2.32	2.38	V	$T_A=-40^{\circ}C$ to $+85^{\circ}C$
	2.24		2.40	V	$T_A=-40^{\circ}C$ to $+125^{\circ}C$
ADM682_Y	2.12	2.19	2.25	V	$T_A=-40^{\circ}C$ to $+85^{\circ}C$
	2.11		2.27	V	$T_A=-40^{\circ}C$ to $+125^{\circ}C$
ADM682_W	1.62	1.67	1.71	V	$T_A=-40^{\circ}C$ to $+85^{\circ}C$
	1.61		1.72	V	$T_A=-40^{\circ}C$ to $+125^{\circ}C$
ADM682_V	1.52	1.58	1.62	V	$T_A=-40^{\circ}C$ to $+85^{\circ}C$
RESET THRESHOLD TEMPERATURE COEFFICIENT		60		ppm/ $^{\circ}C$	
RESET THRESHOLD HYSTERESIS		$2x V_{TH}$		mV	
RESET TIMEOUT PERIOD	140	200	280	ms	
	100		320	ms	
V_{CC} TO RESET DELAY		20		μs	$V_{CC} = V_{TH}$ to $(V_{TH} - 100mV)$
RESET Output Voltage Low			0.4	V	$V_{CC} \geq 4.25V$, $I_{SINK} = 3.2mA$, reset asserted
			0.3	V	$V_{CC} \geq 2.55V$, $I_{SINK} = 1.2mA$, reset asserted
			0.3	V	$V_{CC} \geq 1.25V$, $I_{SINK} = 100\mu A$, reset asserted
			0.3	V	$V_{CC} \geq 1.0V$, $I_{SINK} = 50\mu A$, reset asserted, $T_A = -40^{\circ}C$ to $+85^{\circ}C$
RESET Output Voltage High	$0.8 \times V_{CC}$			V	$V_{CC} \geq 4.75V$, $I_{SOURCE} = 800\mu A$, reset not asserted

Parameter	Min	Typ	Max	Units	Test Conditions/Comments
	$0.8 \times V_{CC}$			V	$V_{CC} > 3.15V$, $I_{SOURCE} = 500\mu A$, reset not asserted
	$0.8 \times V_{CC}$			V	$V_{CC} > 1.8V$, $I_{SOURCE} = 200\mu A$, reset not asserted
RESET Output Voltage High	$0.8 \times V_{CC}$				$V_{CC} > 4.25V$, $I_{SOURCE} = 800\mu A$, reset asserted $V_{CC} > 2.55V$, $I_{SOURCE} = 500\mu A$, reset asserted $V_{CC} > 1.50V$, $I_{SOURCE} = 100\mu A$, reset asserted $V_{CC} > 1.0V$, $I_{SOURCE} = 1\mu A$, reset asserted, $T_A = -40^\circ C$ to $+85^\circ C$
RESET Output Voltage Low			0.4	V	$V_{CC} > 4.75V$, $I_{SINK} = 3.2mA$, reset not asserted
			0.3	V	$V_{CC} > 3.15V$, $I_{SINK} = 1.2mA$, reset not asserted
			0.3	V	$V_{CC} > 1.8V$, $I_{SINK} = 500\mu A$, reset not asserted
WATCHDOG INPUT (ADM6821-ADM6824)					
Watchdog Timeout Period	1.12	1.6	2.40	s	$V_{IL} = 0.4V$, $V_{IH} = 0.8 \times V_{CC}$
WDI Pulse Width	50			ns	
WDI Input Threshold					
V_{IL}			$0.3 \times V_{CC}$	V	
V_{IH}	$0.7 \times V_{CC}$			V	
WDI Input Current		120	160	μA	$V_{WDI} = V_{CC}$, time average
	-20	-15		μA	$V_{WDI} = 0$, time average
MANUAL RESET INPUT (ADM6821-ADM6823/ADM6825)					
\overline{MR} Input Threshold			$0.3 \times V_{CC}$	V	
	$0.7 \times V_{CC}$			V	
\overline{MR} Input Pulse Width	1			μs	
\overline{MR} Glitch Rejection		100		ns	
\overline{MR} Pull-up Resistance	25	50	75	$k\Omega$	
\overline{MR} to Reset Delay		200		ns	

ABSOLUTE MAXIMUM RATINGS

Table 3. $T_A = 25^\circ C$ unless otherwise noted.

Parameter	Rating
V_{CC}	-0.3V to +6V
Output Current (RESET, \overline{RESET})	20mA
Operating Temperature Range	-40°C to +125°C
Storage Temperature Range	-65°C to +150°C
θ_{JA} Thermal Impedance	270°C/W
Lead Temperature	
Soldering (10 sec)	300°C
Vapour Phase (60 sec)	215°C
Infrared (15 sec)	220°C

Stresses above those listed under Absolute Maximum Ratings may cause permanent damage to the device. This is a stress rating only and functional operation of the device at these or any other conditions above those indicated in the operational section of this specification is not implied. Exposure to absolute maximum rating conditions for extended periods may affect device reliability.

PIN CONFIGURATIONS AND FUNCTIONAL DESCRIPTIONS

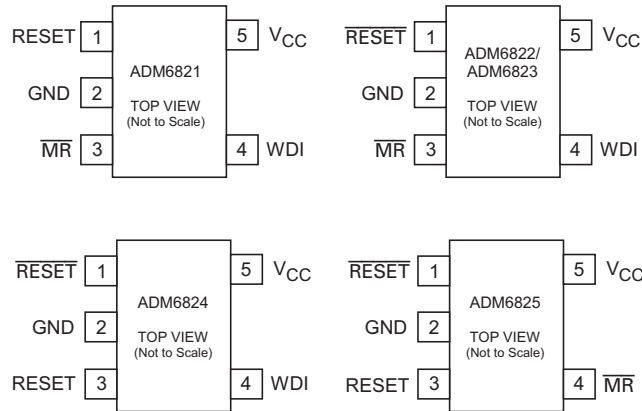

Table 4. Pin Functional Descriptions

Pin No.	Name	Description
1	RESET (ADM6822/23/24/25)	Active-Low Reset Output, which is asserted whenever V_{CC} is below the reset.threshold, V_{TH} . Open-Drain Output Stage for ADM6822. Push-Pull Output Stage for ADM6823/24/25.
	RESET (ADM6821)	Active-High Reset Output
2	GND	Ground
3	MR (ADM6821/22/23)	Manual Reset Input. This is an active-low input which, when forced low for at least 1 μ s, generates a reset. Features a 52k Ω internal pull-up.
	RESET (ADM6824/ADM6825)	Active-High Push-Pull Reset Output.
4	WDI (ADM6821/22/23/24)	Watchdog Input. Generates a reset if the voltage on the pin remains low or high for the duration of the watchdog timeout. The timer is cleared if a logic transition occurs on this pin or if a reset is generated.
	MR (ADM6825)	Manual Reset Input.
5	V_{CC}	Power Supply Voltage being Monitored

ESD CAUTION

ESD (electrostatic discharge) sensitive device. Electrostatic charges as high as 4000 V readily accumulate on the human body and test equipment and can discharge without detection. Although this product features proprietary ESD protection circuitry, permanent damage may occur on devices subjected to high energy electrostatic discharges. Therefore, proper ESD precautions are recommended to avoid performance degradation or loss of functionality.



ORDERING GUIDE

Model	Reset Threshold (V)	Temperature Range	Quantity	Package Type	Branding
ADM6821LART-RL	4.63	-40°C to +125°C	10k	SOT-23-5	NOA
ADM6821LART-RL7	4.63	-40°C to +125°C	3k	SOT-23-5	NOA
ADM6821MART-RL	4.38	-40°C to +125°C	10k	SOT-23-5	NOA
ADM6821MART-RL7	4.38	-40°C to +125°C	3k	SOT-23-5	NOA
ADM6821TART-RL	3.08	-40°C to +125°C	10k	SOT-23-5	NOA
ADM6821TART-RL7	3.08	-40°C to +125°C	3k	SOT-23-5	NOA
ADM6821SART-RL	2.93	-40°C to +125°C	10k	SOT-23-5	NOA
ADM6821SART-RL7	2.93	-40°C to +125°C	3k	SOT-23-5	NOA
ADM6821RART-RL	2.63	-40°C to +125°C	10k	SOT-23-5	NOA
ADM6821RART-RL7	2.63	-40°C to +125°C	3k	SOT-23-5	NOA
ADM6821ZART-RL	2.32	-40°C to +125°C	10k	SOT-23-5	NOA
ADM6821ZART-RL7	2.32	-40°C to +125°C	3k	SOT-23-5	NOA
ADM6821YART-RL	2.19	-40°C to +125°C	10k	SOT-23-5	NOA
ADM6821YART-RL7	2.19	-40°C to +125°C	3k	SOT-23-5	NOA
ADM6821WART-RL	1.67	-40°C to +125°C	10k	SOT-23-5	NOA
ADM6821WART-RL7	1.67	-40°C to +125°C	3k	SOT-23-5	NOA
ADM6821VART-RL	1.58	-40°C to +125°C	10k	SOT-23-5	NOA
ADM6821VART-RL7	1.58	-40°C to +125°C	3k	SOT-23-5	NOA
ADM6822LART-RL	4.63	-40°C to +125°C	10k	SOT-23-5	NOB
ADM6822LART-RL7	4.63	-40°C to +125°C	3k	SOT-23-5	NOB
ADM6822MART-RL	4.38	-40°C to +125°C	10k	SOT-23-5	NOB
ADM6822MART-RL7	4.38	-40°C to +125°C	3k	SOT-23-5	NOB
ADM6822TART-RL	3.08	-40°C to +125°C	10k	SOT-23-5	NOB
ADM6822TART-RL7	3.08	-40°C to +125°C	3k	SOT-23-5	NOB
ADM6822SART-RL	2.93	-40°C to +125°C	10k	SOT-23-5	NOB
ADM6822SART-RL7	2.93	-40°C to +125°C	3k	SOT-23-5	NOB
ADM6822RART-RL	2.63	-40°C to +125°C	10k	SOT-23-5	NOB
ADM6822RART-RL7	2.63	-40°C to +125°C	3k	SOT-23-5	NOB
ADM6822ZART-RL	2.32	-40°C to +125°C	10k	SOT-23-5	NOB
ADM6822ZART-RL7	2.32	-40°C to +125°C	3k	SOT-23-5	NOB
ADM6822YART-RL	2.19	-40°C to +125°C	10k	SOT-23-5	NOB
ADM6822YART-RL7	2.19	-40°C to +125°C	3k	SOT-23-5	NOB
ADM6822WART-RL	1.67	-40°C to +125°C	10k	SOT-23-5	NOB
ADM6822WART-RL7	1.67	-40°C to +125°C	3k	SOT-23-5	NOB
ADM6822VART-RL	1.58	-40°C to +125°C	10k	SOT-23-5	NOB
ADM6822VART-RL7	1.58	-40°C to +125°C	3k	SOT-23-5	NOB
ADM6823LART-RL	4.63	-40°C to +125°C	10k	SOT-23-5	NOC
ADM6823LART-RL7	4.63	-40°C to +125°C	3k	SOT-23-5	NOC
ADM6823MART-RL	4.38	-40°C to +125°C	10k	SOT-23-5	NOC
ADM6823MART-RL7	4.38	-40°C to +125°C	3k	SOT-23-5	NOC
ADM6823TART-RL	3.08	-40°C to +125°C	10k	SOT-23-5	NOC
ADM6823TART-RL7	3.08	-40°C to +125°C	3k	SOT-23-5	NOC
ADM6823SART-RL	2.93	-40°C to +125°C	10k	SOT-23-5	NOC
ADM6823SART-RL7	2.93	-40°C to +125°C	3k	SOT-23-5	NOC
ADM6823RART-RL	2.63	-40°C to +125°C	10k	SOT-23-5	NOC
ADM6823RART-RL7	2.63	-40°C to +125°C	3k	SOT-23-5	NOC
ADM6823ZART-RL	2.32	-40°C to +125°C	10k	SOT-23-5	NOC
ADM6823ZART-RL7	2.32	-40°C to +125°C	3k	SOT-23-5	NOC
ADM6823YART-RL	2.19	-40°C to +125°C	10k	SOT-23-5	NOC
ADM6823YART-RL7	2.19	-40°C to +125°C	3k	SOT-23-5	NOC

ORDERING GUIDE (CONTD.)

Model	Reset Threshold (V)	Temperature Range	Quantity	Package Type	Branding
ADM6823WART-RL	1.67	-40°C to +125°C	10k	SOT-23-5	NOC
ADM6823WART-RL7	1.67	-40°C to +125°C	3k	SOT-23-5	NOC
ADM6823VART-RL	1.58	-40°C to +125°C	10k	SOT-23-5	NOC
ADM6823VART-RL7	1.58	-40°C to +125°C	3k	SOT-23-5	NOC
ADM6824LART-RL	4.63	-40°C to +125°C	10k	SOT-23-5	NOD
ADM6824LART-RL7	4.63	-40°C to +125°C	3k	SOT-23-5	NOD
ADM6824MART-RL	4.38	-40°C to +125°C	10k	SOT-23-5	NOD
ADM6824MART-RL7	4.38	-40°C to +125°C	3k	SOT-23-5	NOD
ADM6824TART-RL	3.08	-40°C to +125°C	10k	SOT-23-5	NOD
ADM6824TART-RL7	3.08	-40°C to +125°C	3k	SOT-23-5	NOD
ADM6824SART-RL	2.93	-40°C to +125°C	10k	SOT-23-5	NOD
ADM6824SART-RL7	2.93	-40°C to +125°C	3k	SOT-23-5	NOD
ADM6824RART-RL	2.63	-40°C to +125°C	10k	SOT-23-5	NOD
ADM6824RART-RL7	2.63	-40°C to +125°C	3k	SOT-23-5	NOD
ADM6824ZART-RL	2.32	-40°C to +125°C	10k	SOT-23-5	NOD
ADM6824ZART-RL7	2.32	-40°C to +125°C	3k	SOT-23-5	NOD
ADM6824YART-RL	2.19	-40°C to +125°C	10k	SOT-23-5	NOD
ADM6824YART-RL7	2.19	-40°C to +125°C	3k	SOT-23-5	NOD
ADM6824WART-RL	1.67	-40°C to +125°C	10k	SOT-23-5	NOD
ADM6824WART-RL7	1.67	-40°C to +125°C	3k	SOT-23-5	NOD
ADM6824VART-RL	1.58	-40°C to +125°C	10k	SOT-23-5	NOD
ADM6824VART-RL7	1.58	-40°C to +125°C	3k	SOT-23-5	NOD
ADM6825LART-RL	4.63	-40°C to +125°C	10k	SOT-23-5	NOE
ADM6825LART-RL7	4.63	-40°C to +125°C	3k	SOT-23-5	NOE
ADM6825MART-RL	4.38	-40°C to +125°C	10k	SOT-23-5	NOE
ADM6825MART-RL7	4.38	-40°C to +125°C	3k	SOT-23-5	NOE
ADM6825TART-RL	3.08	-40°C to +125°C	10k	SOT-23-5	NOE
ADM6825TART-RL7	3.08	-40°C to +125°C	3k	SOT-23-5	NOE
ADM6825SART-RL	2.93	-40°C to +125°C	10k	SOT-23-5	NOE
ADM6825SART-RL7	2.93	-40°C to +125°C	3k	SOT-23-5	NOE
ADM6825RART-RL	2.63	-40°C to +125°C	10k	SOT-23-5	NOE
ADM6825RART-RL7	2.63	-40°C to +125°C	3k	SOT-23-5	NOE
ADM6825ZART-RL	2.32	-40°C to +125°C	10k	SOT-23-5	NOE
ADM6825ZART-RL7	2.32	-40°C to +125°C	3k	SOT-23-5	NOE
ADM6825YART-RL	2.19	-40°C to +125°C	10k	SOT-23-5	NOE
ADM6825YART-RL7	2.19	-40°C to +125°C	3k	SOT-23-5	NOE
ADM6825WART-RL	1.67	-40°C to +125°C	10k	SOT-23-5	NOE
ADM6825WART-RL7	1.67	-40°C to +125°C	3k	SOT-23-5	NOE
ADM6825VART-RL	1.58	-40°C to +125°C	10k	SOT-23-5	NOE
ADM6825VART-RL7	1.58	-40°C to +125°C	3k	SOT-23-5	NOE

OUTLINE DIMENSIONS

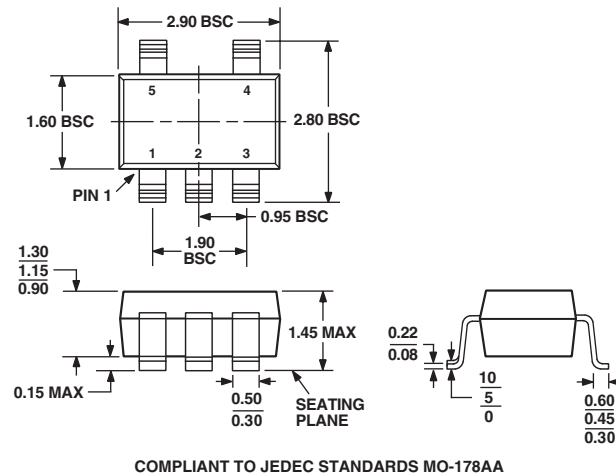

Figure 1. 5-Lead Small Outline Transistor Package [SOT-23]
(RT-5)

Dimensions shown in millimeters