

Features

- Very Low Forward Voltage Drop
- Guard Ring Construction for Transient Protection
- High Conductance
- **Lead Free By Design/RoHS Compliant (Note 3)**
- "Green Device" (Note 4)

Mechanical Data

- Case: SOD-323
- Case Material - Molded Plastic, "Green" Molding Compound. UL Flammability Classification Rating 94V-0
- Moisture sensitivity: Level 1 per J-STD-020C
- Terminal Connections: Cathode Band
- Terminals: Finish — Matte Tin annealed over Alloy 42 leadframe. Solderable per MIL-STD-202, Method 208
- Marking & Type Code Information: See Page 2

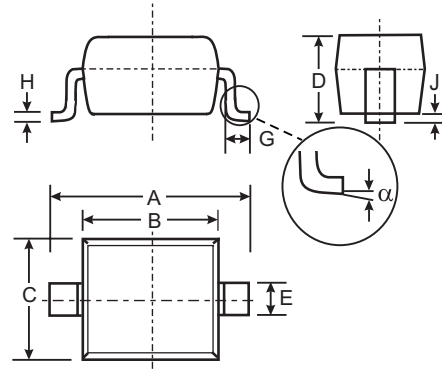

SOD-323		
Dim	Min	Max
A	2.30	2.70
B	1.60	1.80
C	1.20	1.40
D	1.00	1.10
E	0.25	0.35
G	0.20	0.40
H	0.10	0.15
J	0.05 Typical	
α	0°	8°
All Dimensions in mm		

Type Code: LZ

- Ordering Information: See Page 2
- Weight: 0.004 grams (approx.)

Maximum Ratings @ $T_A = 25^\circ\text{C}$ unless otherwise specified

Single phase, half wave, 60Hz, resistive or inductive load.
For capacitive load, derate current by 20%.

Characteristic	Symbol	Value	Unit
Peak Repetitive Reverse Voltage Working Peak Reverse Voltage DC Blocking Voltage	V_{RRM} V_{RWM} V_R	30	V
RMS Reverse Voltage	$V_{R(RMS)}$	21	V
Average Rectified Output Current	I_O	1	A
Non-Repetitive Peak Forward Surge Current 8.3ms single half sine-wave superimposed on rated load (JEDEC Method)	I_{FSM}	5.5	A
Operating and Storage Temperature Range	T_j, T_{STG}	-65 to +125	$^\circ\text{C}$

Thermal Characteristics @ $T_A = 25^\circ\text{C}$ unless otherwise specified

Characteristic	Symbol	Value	Unit
Power Dissipation (Note 1)	P_d	235	mW
Typical Thermal Resistance Junction to Ambient (Note 1)	$R_{\theta JA}$	426	$^\circ\text{C/W}$

Electrical Characteristics @ $T_A = 25^\circ\text{C}$ unless otherwise specified

Characteristic	Symbol	Min	Typ	Max	Unit	Test Conditions
Reverse Breakdown Voltage (Note 2)	$V_{(BR)R}$	30	—	—	V	$I_R = 500\mu\text{A}$
Forward Voltage Drop	V_F	—	245 320 495	270 350 550	mV	$I_F = 10\text{mA}$ $I_F = 100\text{mA}$ $I_F = 1\text{A}$
Leakage Current (Note 2)	I_R	—	3.0 3.5 5.0	10 20 50	μA	$V_R = 5\text{V}$ $V_R = 8\text{V}$ $V_R = 15\text{V}$
Total Capacitance	C_T	—	25	—	pF	$f = 1\text{MHz}, V_R = 5\text{VDC}$

- Note:
1. Part mounted on FR-4 PC board with recommended pad layout, which can be found on our website at <http://www.diodes.com/datasheets/ap02001.pdf>.
 2. Short duration test pulse used to minimize self-heating effect.
 3. No purposefully added lead.
 4. Diodes Inc.'s "Green" policy can be found on our website at http://www.diodes.com/products/lead_free/index.php.

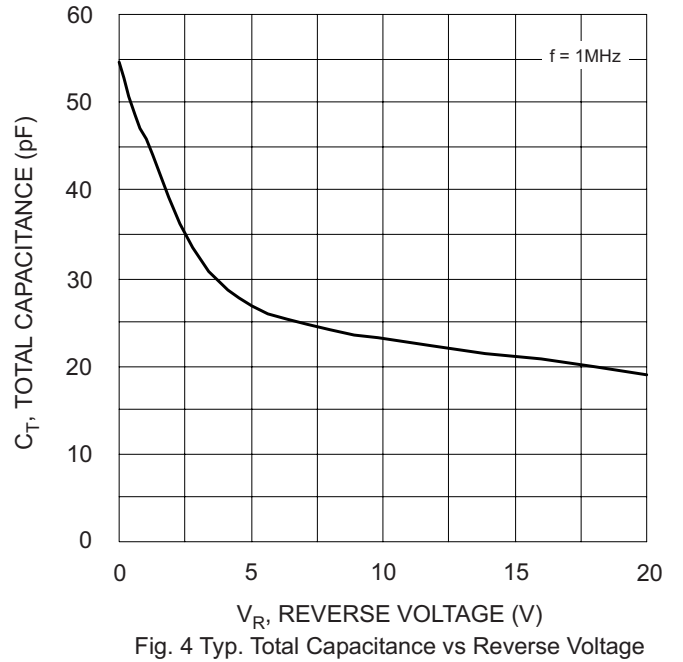
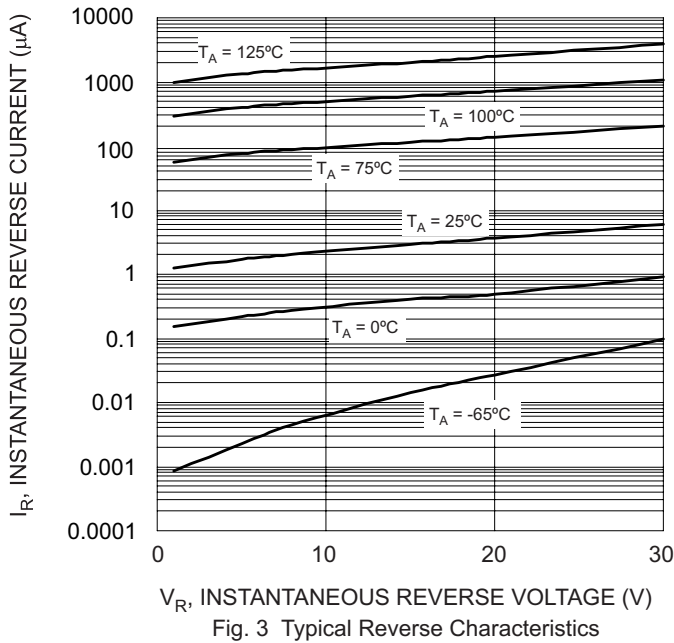
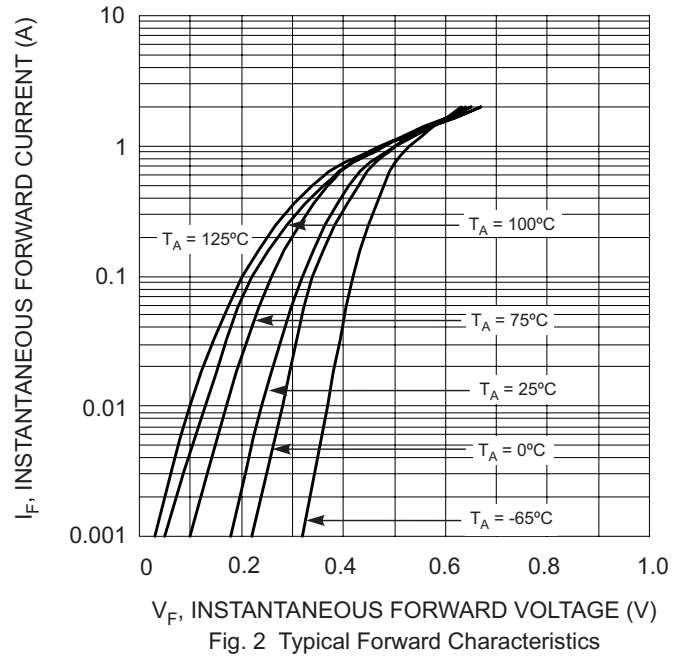
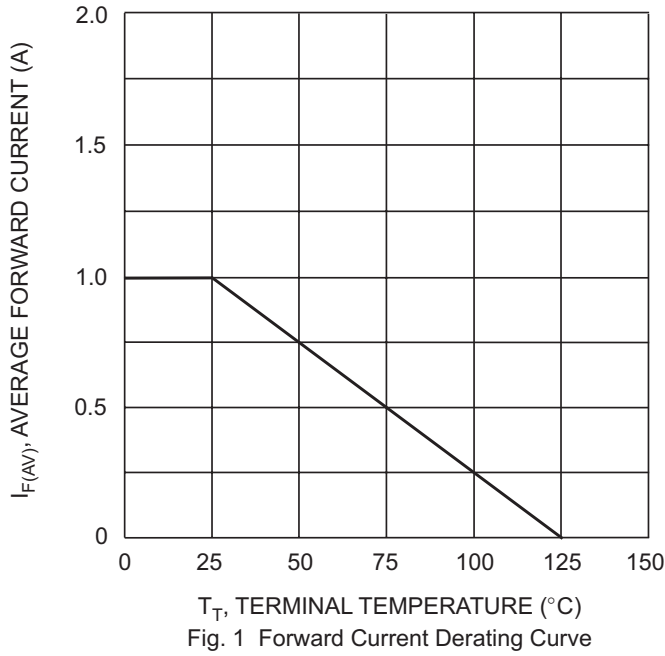

Ordering Information (Note 5)

Device	Packaging	Shipping
BAT760-7	SOD-323	3000/Tape and Reel

Note: 5. For Packaging Details, go to our website at <http://www.diodes.com/datasheets/ap02007.pdf>.

Marking Information

