

Features

- AVR[®] Microcontroller-based Function Controller and Hub
- Binary-compatible with the AT43USB355
- Fully Programmable Full-Speed USB 2.0 Hub with Two External and One Attached Downstream Ports
- Full Speed USB Function with Four Endpoints
- High Performance and Low Power 12/24 MIPS AVR RISC Microcontroller
- 120 Powerful Instructions – Most with 83/41.5 ns Execution Cycle Times
- 24 KB Masked ROM Program Memory
- 1 KB Internal Data SRAM
- 32 x 8 General-purpose Working Registers
- 15 Programmable I/O Port Pins
- 12-channel 10-bit Analog-to-Digital Converter (ADC)
- One 8-bit Timer/Counter with Separate Pre-scaler
- One 16-bit Timer/Counter with Separate Pre-scaler and Two PWMs
- External and Internal Interrupt Sources
- Programmable Watchdog Timer
- Low Power Suspend Mode
- 6 MHz Crystal Oscillator with PLL
- 5V Operation with On-chip 3.3V Regulators
- 48-lead LQFP Package



Low Cost USB Microcontroller with Hub, ADC and PWM

AT43USB353M

Summary

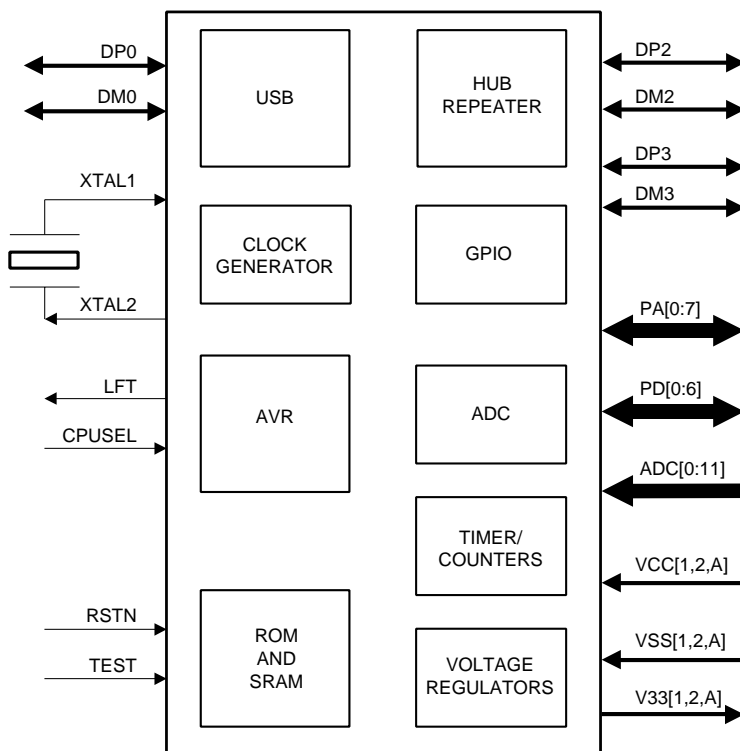



Overview

The Atmel AT43USB353M is a full-speed USB AVR-based microcontroller with a full-speed USB 2.0 compliant embedded hub especially suitable for use in applications requiring Analog-to-Digital converters (ADCs) and PWMs such as in force feedback game controllers. The USB hub has 3 downstream ports, one of which is permanently attached to the USB function. The USB function controller has its own device address and endpoints. In game controller applications, the two external downstream USB ports can be used to connect other devices such as headphone sets for voice commands flash memory modules or any other USB device.

The MCU of the AT43USB353M is a high performance 8-bit AVR RISC that operates at a clock frequency of 12 MHz or 24 MHz. Its program memory is a 24-Kbyte mask programmable ROM and its data memory is 1-Kbyte SRAM. The ADC has a minimum conversion time of 12 ms that together with the 12 input channels should cover even the most demanding game controllers such as gamepads, joysticks and racing wheels. The two PWM outputs can be programmed for 8-, 9- or 10-bit resolution for applications requiring force feedback. The 15 general-purpose programmable I/O pins provide generous inputs for the various buttons and switches and LED indicators that are being used in increasing numbers in today's game controllers.

The USB function has one control endpoint and three additional programmable endpoints, each with their own FIFOs. Two of the endpoints have a 64-byte FIFO each, while the third has an 8-byte FIFO. The USB hardware supports the physical and link layers of the USB protocol while the transaction layer function must be implemented in the MCU's firmware. The AVR architecture was developed to be efficiently programmed in C and without loss in performance.

The AT43USB353M is binary-compatible with the AT43USB355. Firmware written for the AT43USB355 will run on the AT43USB353M without modification as long as only features common to both devices are used.

Development Support

The AT43USB353M uses the same program and development tools as the AT43USB355 and other Atmel AVR microcontrollers including: C compilers, macro assemblers, program debuggers/simulators, in-circuit emulators. The development kit is the AT43DK355, which comes with USB firmware library and sample source code for the most common USB applications.

Ordering Information

Program Memory	Ordering Code	Package	Operation Range
Mask ROM	AT43USB353M-AC	48 LQFP	Commercial (0°C to 70°C)

Package Type	
48AA	48-lead, 7 x 7 mm Body Size, Low Profile Plastic Quad Flat Package (LQFP)

Packaging Information

48AA – LQFP

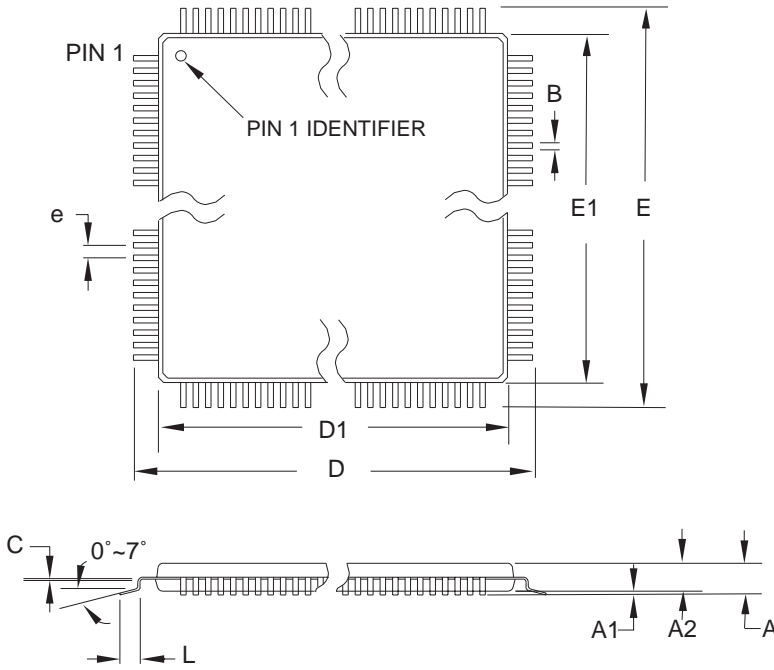

COMMON DIMENSIONS
(Unit of Measure = mm)

SYMBOL	MIN	NOM	MAX	NOTE
A	–	–	1.60	
A1	0.05	–	0.15	
A2	1.35	1.40	1.45	
D	8.75	9.00	9.25	
D1	6.90	7.00	7.10	Note 2
E	8.75	9.00	9.25	
E1	6.90	7.00	7.10	Note 2
B	0.17	–	0.27	
C	0.09	–	0.20	
L	0.45	–	0.75	
e	0.50 TYP			

- Notes:
1. This package conforms to JEDEC reference MS-026, Variation BBC.
 2. Dimensions D1 and E1 do not include mold protrusion. Allowable protrusion is 0.25 mm per side. Dimensions D1 and E1 are maximum plastic body size dimensions including mold mismatch.
 3. Lead coplanarity is 0.08 mm maximum.

10/5/2001

2325 Orchard Parkway San Jose, CA 95131	TITLE	DRAWING NO.	REV.
	48AA , 48-lead, 7 x 7 mm Body Size, 1.4 mm Body Thickness, 0.5 mm Lead Pitch, Low Profile Plastic Quad Flat Package (LQFP)	48AA	C



Atmel Headquarters

Corporate Headquarters

2325 Orchard Parkway
San Jose, CA 95131
TEL 1(408) 441-0311
FAX 1(408) 487-2600

Europe

Atmel Sarl
Route des Arsenaux 41
Case Postale 80
CH-1705 Fribourg
Switzerland
TEL (41) 26-426-5555
FAX (41) 26-426-5500

Asia

Room 1219
Chinachem Golden Plaza
77 Mody Road Tsimshatsui
East Kowloon
Hong Kong
TEL (852) 2721-9778
FAX (852) 2722-1369

Japan

9F, Tonetsu Shinkawa Bldg.
1-24-8 Shinkawa
Chuo-ku, Tokyo 104-0033
Japan
TEL (81) 3-3523-3551
FAX (81) 3-3523-7581

Atmel Operations

Memory

2325 Orchard Parkway
San Jose, CA 95131
TEL 1(408) 441-0311
FAX 1(408) 436-4314

Microcontrollers

2325 Orchard Parkway
San Jose, CA 95131
TEL 1(408) 441-0311
FAX 1(408) 436-4314

La Chantrerie
BP 70602
44306 Nantes Cedex 3, France
TEL (33) 2-40-18-18-18
FAX (33) 2-40-18-19-60

ASIC/ASSP/Smart Cards

Zone Industrielle
13106 Rousset Cedex, France
TEL (33) 4-42-53-60-00
FAX (33) 4-42-53-60-01

1150 East Cheyenne Mtn. Blvd.
Colorado Springs, CO 80906
TEL 1(719) 576-3300
FAX 1(719) 540-1759

Scottish Enterprise Technology Park
Maxwell Building
East Kilbride G75 0QR, Scotland
TEL (44) 1355-803-000
FAX (44) 1355-242-743

RF/Automotive

Theresienstrasse 2
Postfach 3535
74025 Heilbronn, Germany
TEL (49) 71-31-67-0
FAX (49) 71-31-67-2340

1150 East Cheyenne Mtn. Blvd.
Colorado Springs, CO 80906
TEL 1(719) 576-3300
FAX 1(719) 540-1759

Biometrics/Imaging/Hi-Rel MPU/ High Speed Converters/RF Datacom

Avenue de Rochepleine
BP 123
38521 Saint-Egreve Cedex, France
TEL (33) 4-76-58-30-00
FAX (33) 4-76-58-34-80

e-mail

literature@atmel.com

Web Site

<http://www.atmel.com>

© Atmel Corporation 2003.

Atmel Corporation makes no warranty for the use of its products, other than those expressly contained in the Company's standard warranty which is detailed in Atmel's Terms and Conditions located on the Company's web site. The Company assumes no responsibility for any errors which may appear in this document, reserves the right to change devices or specifications detailed herein at any time without notice, and does not make any commitment to update the information contained herein. No licenses to patents or other intellectual property of Atmel are granted by the Company in connection with the sale of Atmel products, expressly or by implication. Atmel's products are not authorized for use as critical components in life support devices or systems.

Atmel® and AVR® are the registered trademarks of Atmel.

Other terms and product names may be the trademarks of others.



Printed on recycled paper.