



## LM224

### LINEAR INTEGRATED CIRCUIT

## QUADRUPLE OPERATIONAL AMPLIFIERS

### DESCRIPTION

UTC LM224 consist of four independent, high-gain, frequency-compensated operational amplifiers which are designed to operate from a single power supply over a wide range of voltage. Operation from split supplies is also possible so long as the difference between the two supplies is 3V ~ 30V. The low supply current drain is independent of the magnitude of the supply voltage.

The device can easily be implemented in single supply voltage system, including transducer amplifiers, DC gain blocks, and all of conventional OP Amp circuits.

### FEATURES

- \* Wide Supply Voltage Range.(Single Supply: 3~30V)
- \* Low Supply Current Drain Independent of Supply Voltage: 0.8 mA Typ
- \* Large DC voltage gain: 100dB
- \* Input Common-Mode Voltage Range Includes Ground.
- \* Low Input Bias and Offset Parameters
- \* Differential Input Voltage Range Equal to Maximum Rated Supply Voltage: 32V
- \* Open-Loop Differential Voltage Amplification: 100 V/mV Typ
- \* Internal Frequency Compensation for Unity Gain

### ORDERING INFORMATION

Ordering Number		Package	Packing
Normal	Lead Free Plating		
LM224-D14-T	LM224L-D14-T	DIP-14	Tube
LM224-S14-R	LM224L-S14-R	SOP-14	Tape Reel
LM224-S14-T	LM224L-S14-T	SOP-14	Tube
LM224-P14-R	LM224L-P14-R	TSSOP-14	Tape Reel
LM224-P14-T	LM224L-P14-T	TSSOP-14	Tube

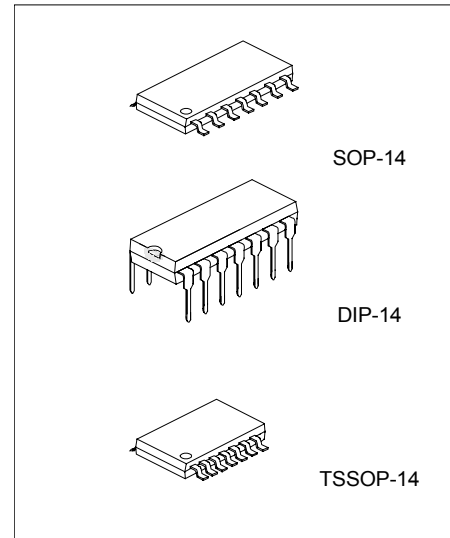

\*Pb-free plating product number: LM224L

### ■ PIN CONFIGURATION

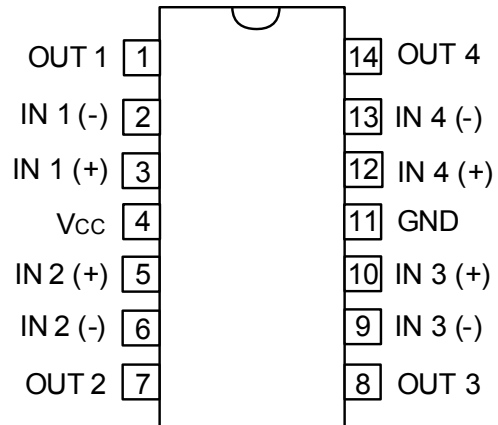

### ■ ABSOLUTE MAXIMUM RATINGS

PARAMETER	SYMBOL	RATINGS	UNIT
Supply Voltage (Note 1)	$V_{CC}$	32	V
Differential Input voltage (Note 2)	$V_{I(DIFF)}$	$\pm 32$	V
Input Voltage	$V_{IN}$	-0.3 ~ +32	V
Output Short Circuit (one amplifier) to Ground ( $T_a \leq 25$ , $V_{CC} \leq 15V$ ) (Note 3)		Continuous	
Power Dissipation( $T_a=25^\circ C$ )	$P_D$	900	mW
Operation Temperature (Note 4)	$T_{OPR}$	-25 ~ +85	
Storage Temperature	$T_{STG}$	-40 ~ +150	

NOTES: 1.All voltage values(except differential voltages and  $V_{CC}$  specified for the measurement of  $I_{IN(OS)}$ ) are with respect to the network GND.

2. Differential voltages are at  $IN+$  with respect to  $IN-$ .

3. Short circuits from outputs to  $V_{CC}$  can cause excessive heating and eventual destruction.

4.The device is guaranteed to meet performance specification within 0 ~70 operating temperature range and assured by design from -25 ~+85 .

### ■ ELECTRICAL CHARACTERISTICS ( $V_{CC}=5V$ , unless otherwise specified, $V_{CC}=30V$ for testing only.)

PARAMETER	SYMBOL	$T_a$ ( )	TEST CONDITIONS*	MIN	TYP	MAX	UNIT	
Input Offset Voltage	$V_{IN(OS)}$	25	$V_{CC}=5V$ to 30V, $V_{IC}=V_{ICR(min)}$ , $V_{OUT}=1.4V$		3	5	mV	
		-25~85				7		
Input Offset Current	$I_{IN(OS)}$	25	$V_{OUT}=1.4V$		2	30	nA	
		-25~85				100		
Input Bias Current	$I_B$	25	$V_{OUT}=1.4V$		-20	-150	nA	
		-25~85				-300		
Input Common-mode Voltage Range	$V_{ICR}$	25	$V_{CC}=5V$ to 30V	0~( $V_{CC}-1.5$ )			V	
		-25~85		0~( $V_{CC}-2$ )				
Output Voltage Level	High	25	$R_L=2k\Omega$	$V_{CC}-1.5$			V	
		-25~85	$V_{CC}=30V$ , $R_L=2k\Omega$	26				
		-25~85	$V_{CC}=30V$ , $R_L \geq 10k\Omega$	27	28			
	Low	$V_{OL}$	-25~85	$R_L \leq 10k\Omega$		5	20	mV
Large Signal Current Gain	$G_V$	25	$V_{CC}=15V$ , $V_{OUT}=1V \sim 11V$ $R_L \geq 2k\Omega$	50	100		V/mV	
		-25~85		25				
Common-mode Rejection Ratio	CMRR	25	$V_{IC}=V_{ICR(min)}$	70	80		dB	
Supply Voltage Rejection Ratio ( $\Delta V_{CC}/\Delta V_{IO}$ )	SVR	25		65	100		dB	
Crosstalk Attenuation	$V_{O1}/V_{O2}$	25	$f=1kHz \sim 20kHz$		120		dB	
Output Current	$I_{OUT}$	25	$V_{CC}=15V$ , $V_{ID}=1V$ , $V_{OUT}=0$	-20	-30	-60	mA	
		-25~85		-10				
		25	$V_{CC}=15V$ , $V_{ID}=-1V$ , $V_{OUT}=15V$	10	20			
		-25~85		5				
25	$V_{ID}=-1V$ , $V_{OUT}=200mV$	12	30		$\mu A$			
Short-circuit Output Current	$I_{OS}$	25	$V_{CC}=5V$ , $V_{OUT}=0$ , GND at -5V		$\pm 40$	$\pm 60$	mA	
Supply Current (four amplifiers)	$I_{CC}$	-25~85	$V_{OUT}=2.5V$ , $R_L=$		0.7	1.2	mA	
			$V_{CC}=30V$ , $V_{OUT}=0.5V_{CC}$ , $R_L=$		1.4	3		

Note: All characteristics are measured under open-loop conditions with zero common-mode input voltage.

### ■ THERMAL DATA

PARAMETER	SYMBOL	RATINGS	UNIT
Thermal Resistance Junction-Ambient	SOP-14	86	/W
	DIP-14	80	
	TSSOP-14	113	

■ SCHEMATIC DIAGRAM(One Section Only)

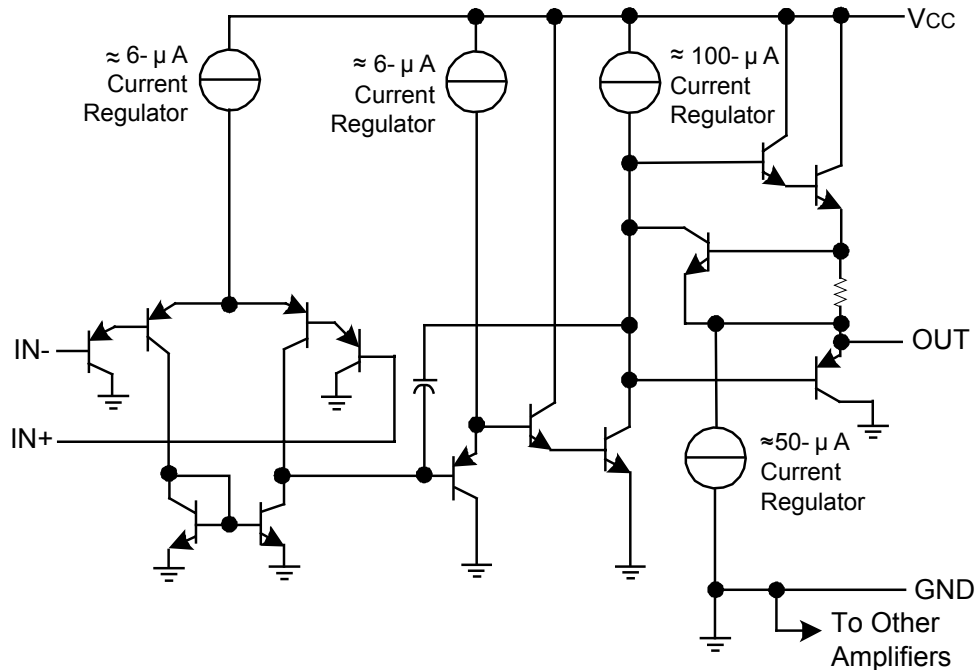

UTC assumes no responsibility for equipment failures that result from using products at values that exceed, even momentarily, rated values (such as maximum ratings, operating condition ranges, or other parameters) listed in products specifications of any and all UTC products described or contained herein. UTC products are not designed for use in life support appliances, devices or systems where malfunction of these products can be reasonably expected to result in personal injury. Reproduction in whole or in part is prohibited without the prior written consent of the copyright owner. The information presented in this document does not form part of any quotation or contract, is believed to be accurate and reliable and may be changed without notice.