



### Ordering Information

ZL60404TBD TO-56 with lens  
 ZL60404TDD ST type connector  
 ZL60404TED SC type connector  
 ZL60404TFD FC type connector

**-40°C to +85°C**

### Description

The Fabry-Perot Laser Diode Receptacle type series is designed for use with SC, FC and ST type fiber connectors as source in telecom and datacom applications.

The ZL60404 is a 1310 nm MQW (Multiple Quantum Well) Fabry-Perot laser diode, integrated with a monitor diode.

The hermetically sealed package includes a ball lens for improved coupling efficiency.

### Features

- Uncooled 1300 nm Fabry-Perot Laser Diode
- Wide operating temperature range -40°C to +85°C
- High reliability
- Built-in monitor diode
- 1.25 Gbps
- Ball lens or receptacle type of packaging

### Applications

- Fiber Channel and Gigabit Ethernet applications up to 1.25 Gbps
- Optical communications systems

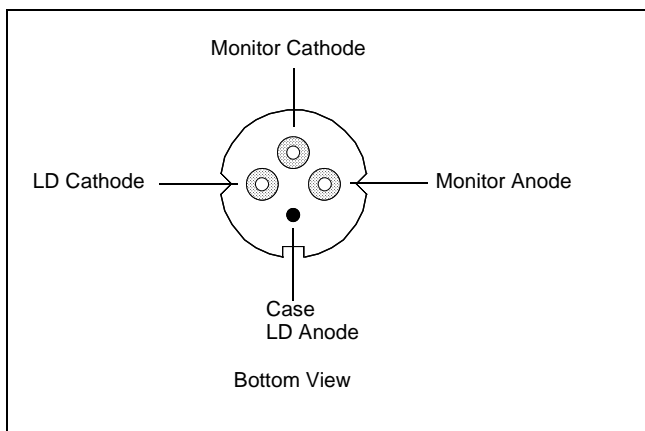

**Figure 1 - PIN Diagram**

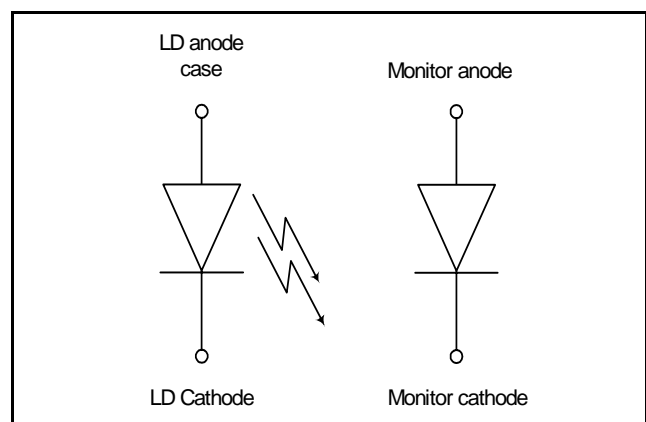

**Figure 2 - Functional Schematic**

**Electrical and Optical Characteristics ( $T_C = 25^\circ\text{C}$ )**

Parameter	Symbol	Conditions	Min.	Typ.	Max.	Unit
Threshold Current	$I_{th}$	CW		10	15	mA
Operating Voltage	$V_{op}$	CW, $I_f = I_{th} + 20\text{ mA}$		1.3	1.5	V
Optical Output Power	$P_f$	CW, $I_f = I_{th} + 20\text{ mA}$		0.6		mW
Wavelength	$\lambda$	CW, $I_{th} + 20\text{ mA}$	1290	1310	1330	nm
Spectral Width	$\Delta\lambda$	CW, $I_{th} + 20\text{ mA}$		1	3	nm
Rise and Fall Times	$t_r, t_f$	$I_f = I_{th} + 20\text{ mA}$ , 20-80%			300	ps
Tracking Error	$\Delta P_f / P_f$	APC, $0 - +70^\circ\text{C}$ $-40^\circ\text{C} - +85^\circ\text{C}$	-1.5 -2.5		1.5 2.5	dB
Monitor Current	$I_D$	CW, $I_{th} + 20\text{ mA}$ , $V_{RD} = 1\text{ V}$	100			$\mu\text{A}$
Monitor Dark Current	$I_D$	$V_{RD} = 5\text{ V}$			1	$\mu\text{A}$
Monitor Capacitance	$C_D$	$V_{RD} = 5\text{ V}$ , $f = 1\text{ MHz}$		10	15	pF

**Absolute Maximum Ratings**

Parameter	Symbol	Rating	Unit
LD Reverse Voltage	$V_{RL}$	2	V
PD Reverse Voltage	$V_{RD}$	20	V
PD Forward Current	$I_f$	2.0	mA
Operating Temperature	$T_{op}$	-40 - +85	$^\circ\text{C}$
Storage Temperature	$T_{stg}$	-40 - +85	$^\circ\text{C}$

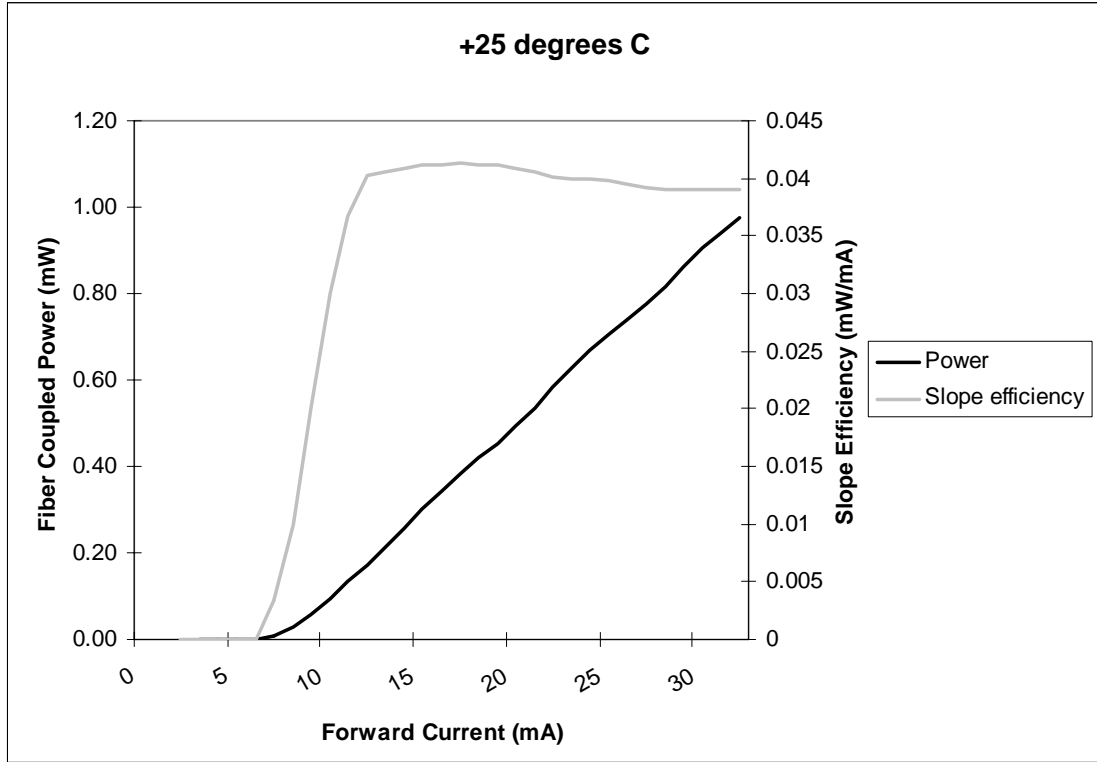

Figure 3 - Typical Fiber Coupled Power and Slope Efficiency at Room Temperature

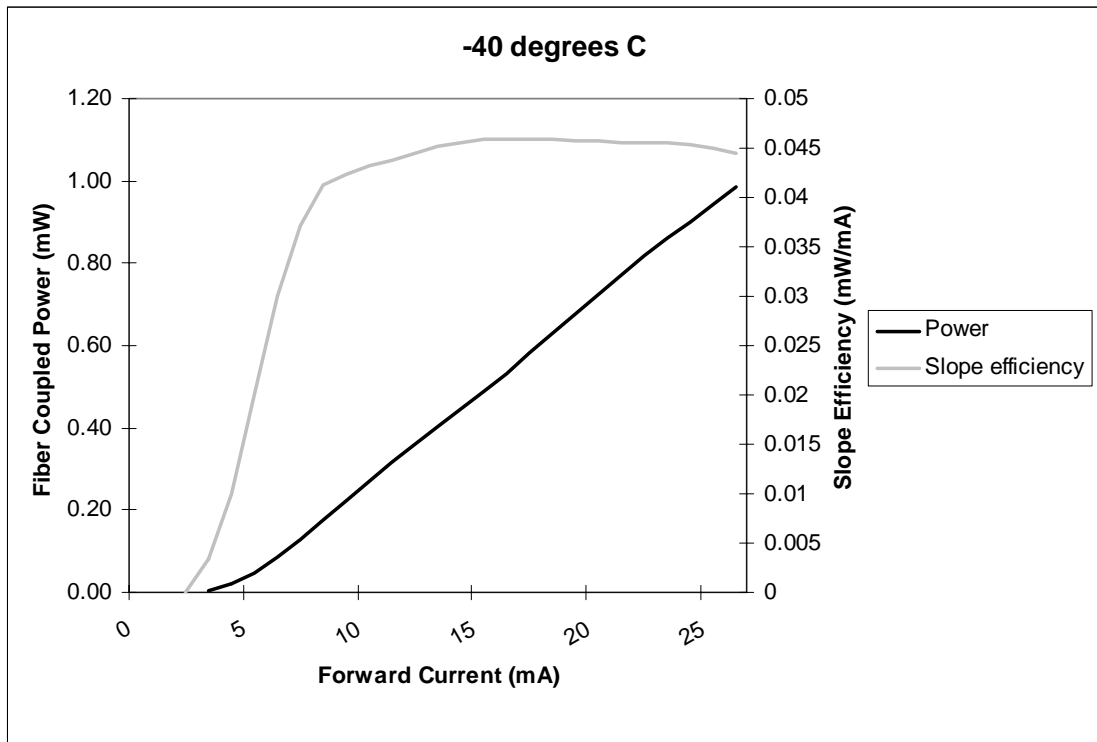

Figure 4 - Typical Fiber Coupled Power and Slope Efficiency at Low Temperature

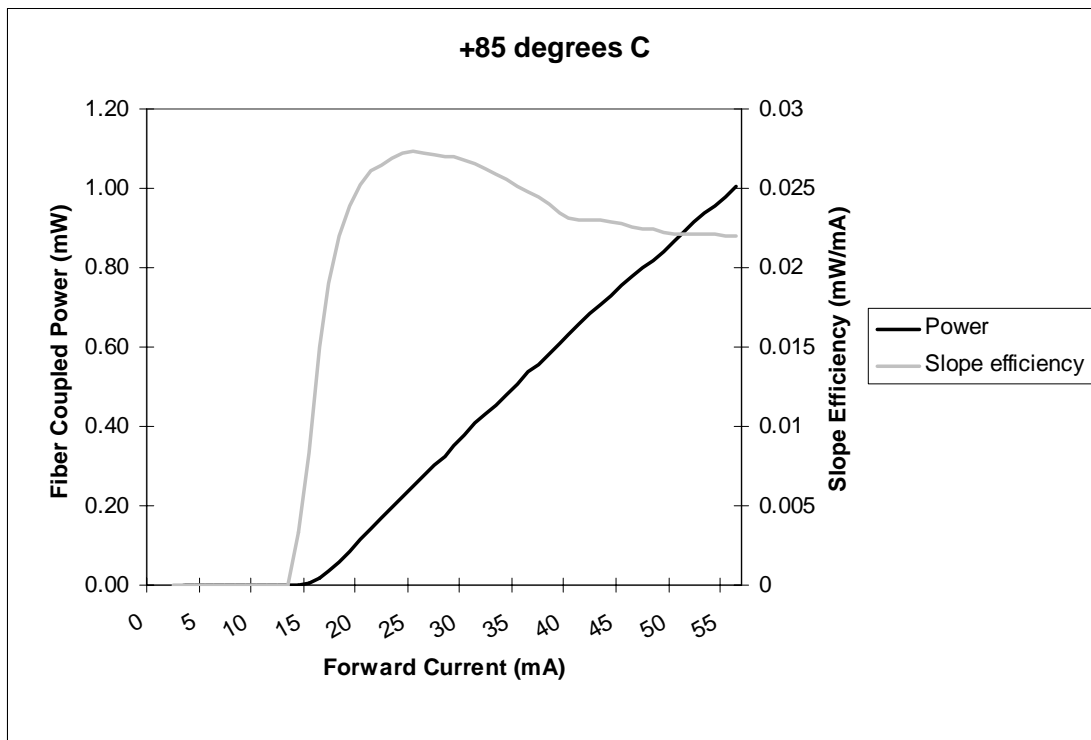
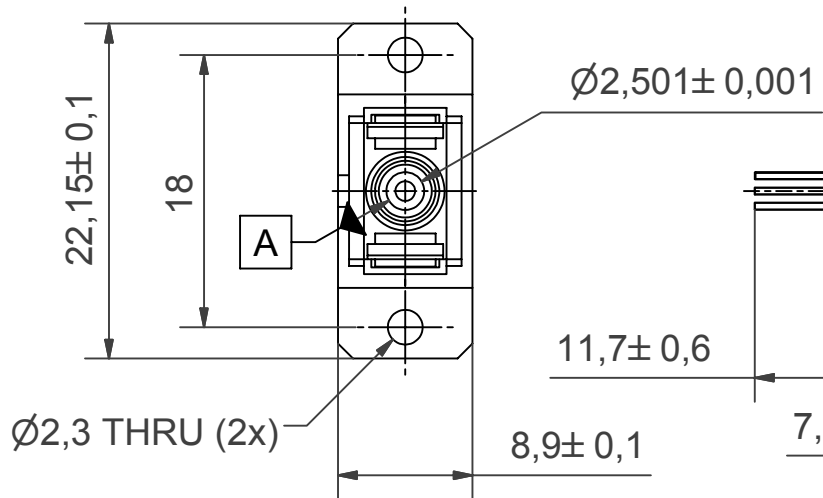
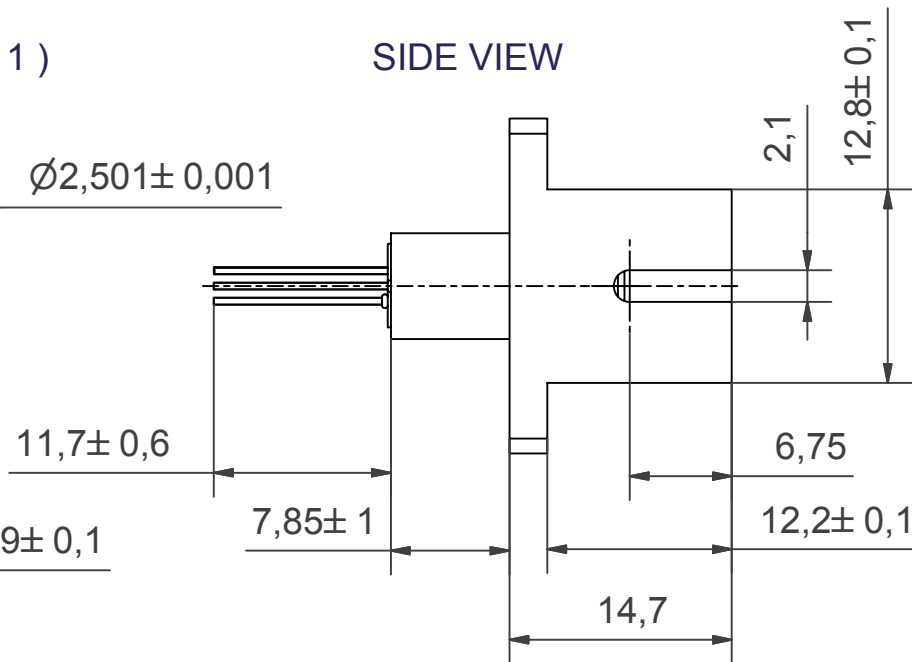

Figure 5 - Typical Fiber Coupled Power and Slope Efficiency at High Temperature

FRONT VIEW ( 2 : 1 )



SIDE VIEW



BOTTOM VIEW

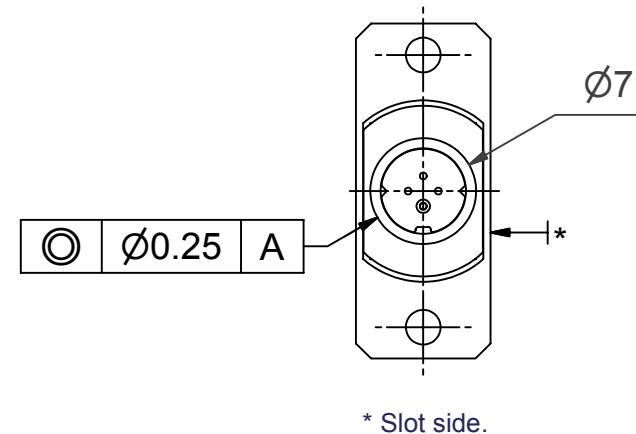

ISOMETRIC VIEW

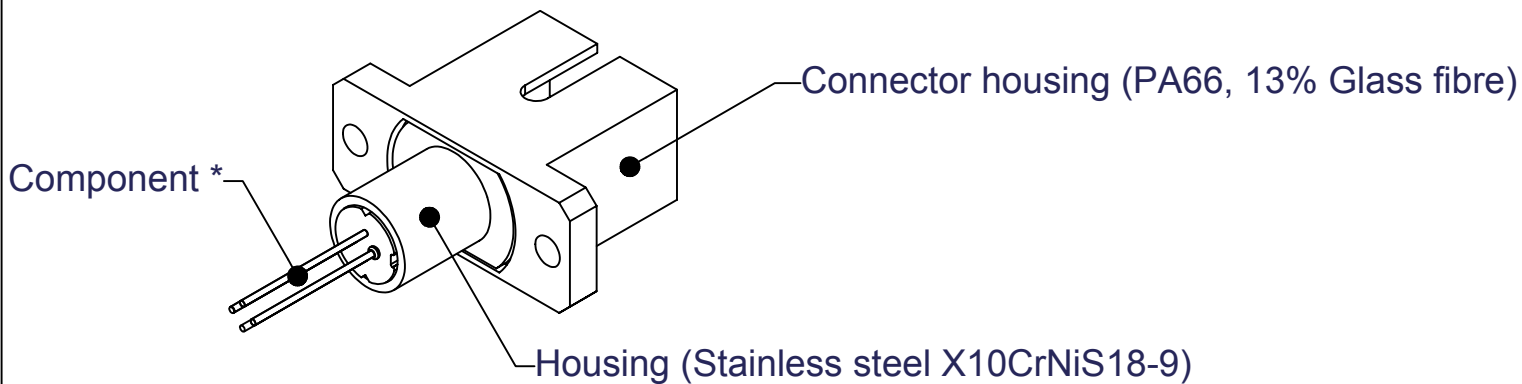

NOTES:-

1. All dimensions in mm.
2. General tol. ISO-2768-mK.

\* For details of the component, see separate data sheet and/or package drawing.

Projection

© Zarlink Semiconductor 2002. All rights reserved.				
ISSUE	1			
ACN	101512rev 1			
DATE	17-NOV-03			
APPRD.	PD\US			



	Package code <b>TE</b>
Previous package codes	Drawing type TO-56 Package Outline in SC Connector housing
	Title <b>101512</b>

FRONT VIEW ( 2 : 1 )

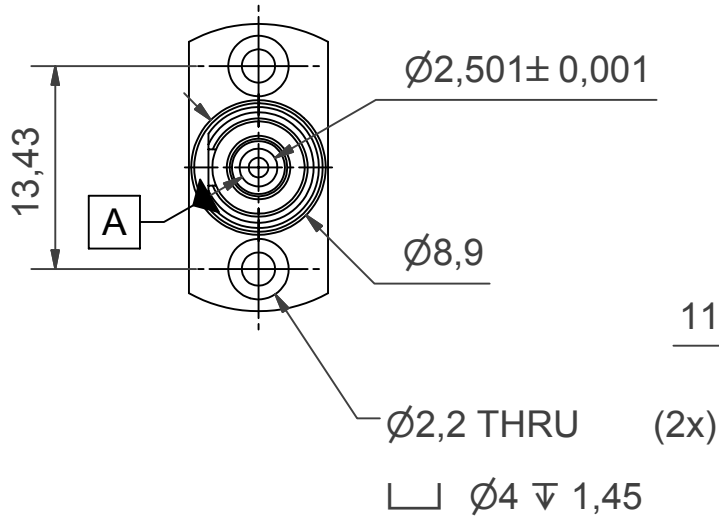

SIDE VIEW

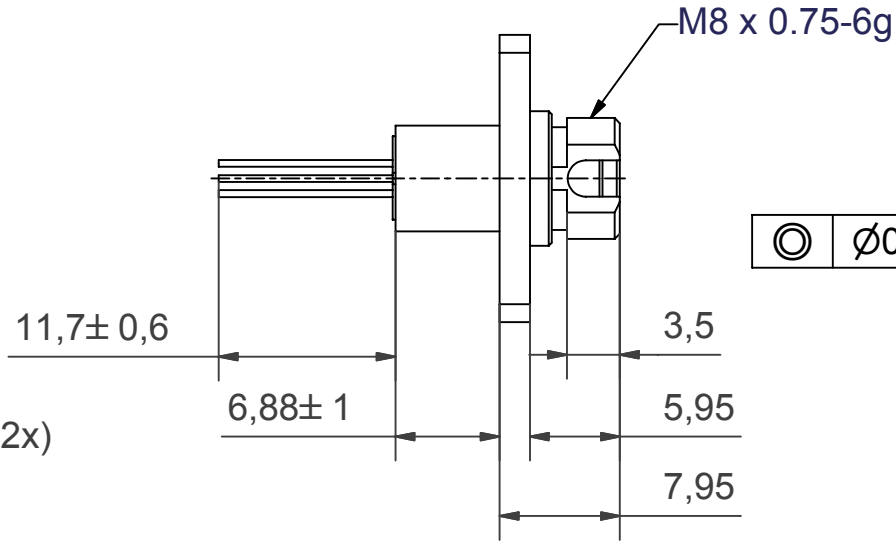

BOTTOM VIEW

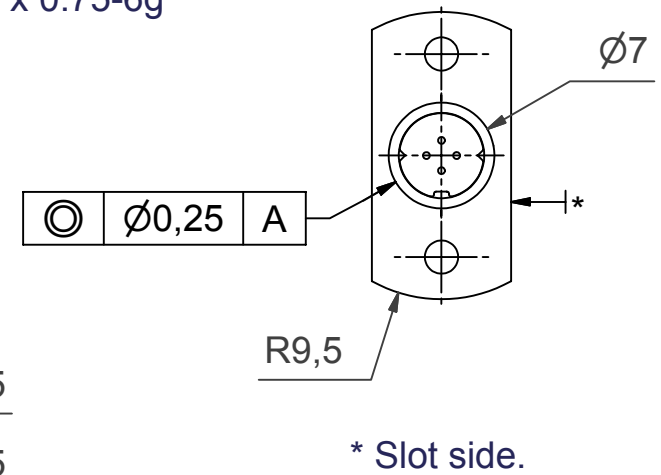

ISOMETRIC VIEW

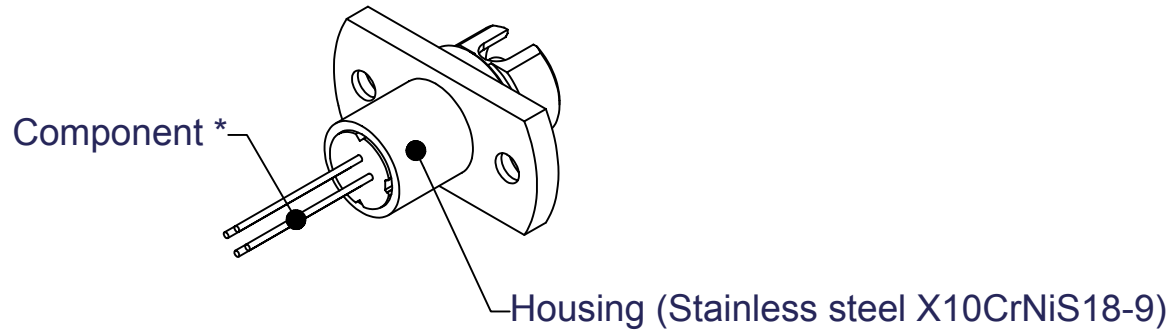

NOTES:-

1. All dimensions in mm.
2. General tol. ISO-2768-mK.

\* For details of the component, see separate data sheet and/or package drawing.

Projection

© Zarlink Semiconductor 2002. All rights reserved.

ISSUE	1			
ACN	101513 rev1			
DATE	17-NOV-03			
APPRD.	PD\US			



Previous package codes

Package code **TF**

Drawing type  
TO-56 Package Outline in FC  
Connector housing

Title  
**101513**

# BOTTOM VIEW ( 10 : 1 )

# SIDE VIEW

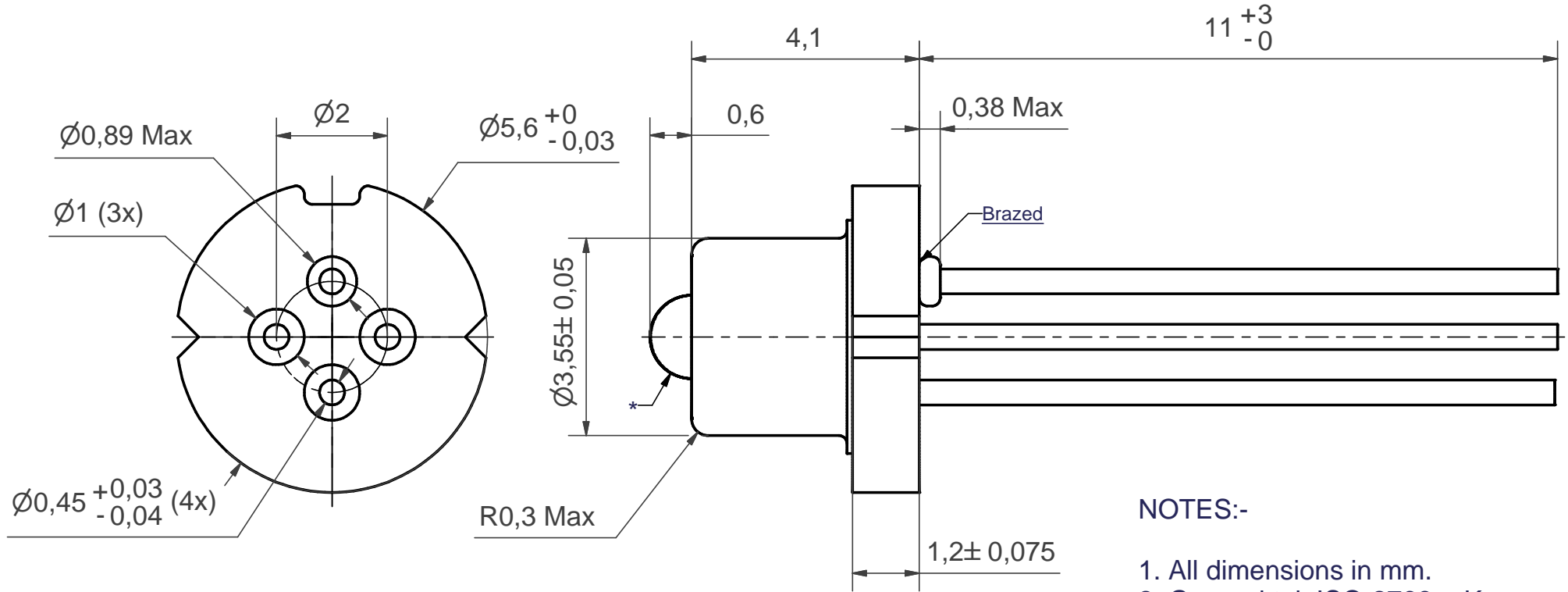

### NOTES:-

1. All dimensions in mm.
2. General tol. ISO-2768-mK.
3. Coating: Case: Ni 3-7  $\mu$ m.  
Header: Ni 2-4  $\mu$ m / Au 0,5  $\mu$ m.

\* Lens  $\varnothing 1,5 \pm 0,002$

Projection Method

© Zarlink Semiconductor 2002. All rights reserved.				
ISSUE	1			
ACN	101615 rev1			
DATE	21-NOV-03			
APPRD.	MD/MA			



	Package code <b>TB</b>
Previous package codes	Drawing type Package Drawing, TO-56 with lens
	Title <b>101615</b>

FRONT VIEW ( 2 : 1 )

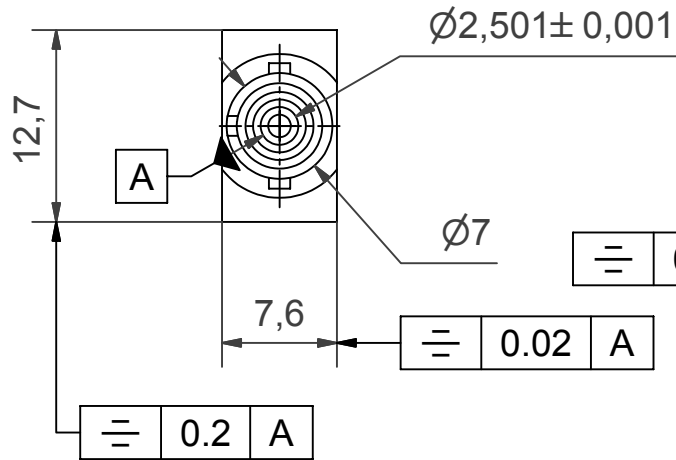

SIDE VIEW

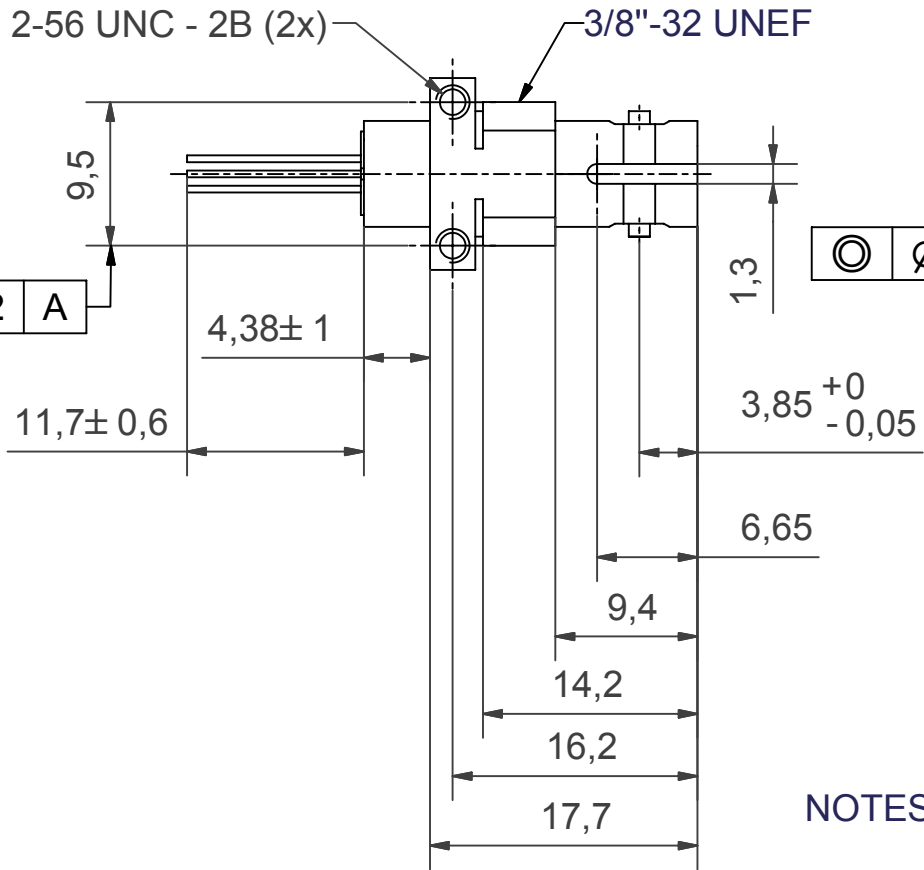

BOTTOM VIEW

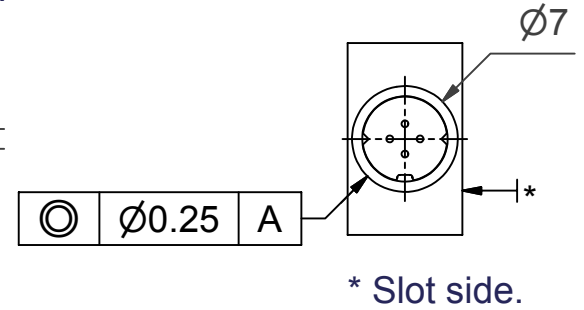

ISOMETRIC VIEW

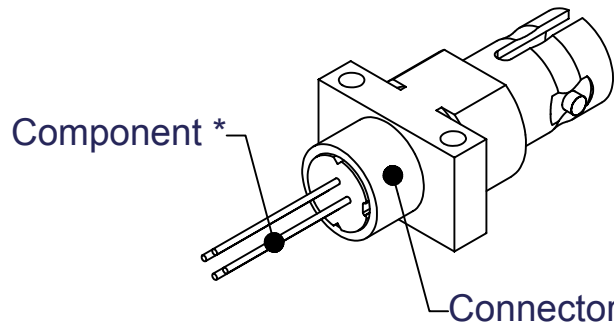

NOTES:-

1. All dimensions in mm.
2. General tol. ±0.1 mm.

\* For details of the component, see separate data sheet and/or package drawing.

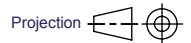

© Zarlink Semiconductor 2002. All rights reserved.

ISSUE	1			
ACN	101514 rev1			
DATE	17-NOV-03			
APPRD.	PD\US			



Previous package codes

Package code **TD**

Drawing type  
TO-56 Package Outline in ST  
Connector housing

Title  
**101514**





**For more information about all Zarlink products  
visit our Web Site at  
[www.zarlink.com](http://www.zarlink.com)**

Information relating to products and services furnished herein by Zarlink Semiconductor Inc. or its subsidiaries (collectively "Zarlink") is believed to be reliable. However, Zarlink assumes no liability for errors that may appear in this publication, or for liability otherwise arising from the application or use of any such information, product or service or for any infringement of patents or other intellectual property rights owned by third parties which may result from such application or use. Neither the supply of such information or purchase of product or service conveys any license, either express or implied, under patents or other intellectual property rights owned by Zarlink or licensed from third parties by Zarlink, whatsoever. Purchasers of products are also hereby notified that the use of product in certain ways or in combination with Zarlink, or non-Zarlink furnished goods or services may infringe patents or other intellectual property rights owned by Zarlink.

This publication is issued to provide information only and (unless agreed by Zarlink in writing) may not be used, applied or reproduced for any purpose nor form part of any order or contract nor to be regarded as a representation relating to the products or services concerned. The products, their specifications, services and other information appearing in this publication are subject to change by Zarlink without notice. No warranty or guarantee express or implied is made regarding the capability, performance or suitability of any product or service. Information concerning possible methods of use is provided as a guide only and does not constitute any guarantee that such methods of use will be satisfactory in a specific piece of equipment. It is the user's responsibility to fully determine the performance and suitability of any equipment using such information and to ensure that any publication or data used is up to date and has not been superseded. Manufacturing does not necessarily include testing of all functions or parameters. These products are not suitable for use in any medical products whose failure to perform may result in significant injury or death to the user. All products and materials are sold and services provided subject to Zarlink's conditions of sale which are available on request.

Purchase of Zarlink's I<sup>2</sup>C components conveys a licence under the Philips I<sup>2</sup>C Patent rights to use these components in and I<sup>2</sup>C System, provided that the system conforms to the I<sup>2</sup>C Standard Specification as defined by Philips.

Zarlink, ZL and the Zarlink Semiconductor logo are trademarks of Zarlink Semiconductor Inc.

Copyright Zarlink Semiconductor Inc. All Rights Reserved.

**TECHNICAL DOCUMENTATION - NOT FOR RESALE**

---