

## RoHS Compliant 1X9 SC Duplex Receptacle Transceiver Module for Gigabit Ethernet



### Features

- Industry Standard 1 x 9 Footprint and duplex SC Connector interface
- Compliant with Specifications for IEEE 802.3z Gigabit Ethernet
- OPT-1250Bxxx compliant with the 1.0625GBd Fibre Channel 100-SM-LC-L FC-PI Rev.13
- OPT-1250Axxx compliant with the 1.0625GBd Fibre Channel FC-PI 100-M5-SN-I Rev.13
- Single +3.3V or 5V Power Supply
- PECL or TTL Receiver Signal Detect Indicator
- Wave Solderable and Aqueous Washable
- Laser Class 1 Product which comply with the requirements of IEC 60825-1 and IEC 60825-2

### Description

The OPT-1250xxxx series from DELTA is a 1X9 transceiver module designed expressly for high-speed communication applications that require rates of up to 1.25Gbit/sec. It is compliant with the Gigabit Ethernet standards as well as 1x Fiber channel standards.

The OPT-1250xxxx transceivers are provided with the SC receptacle that is compatible with the industry standard SC connector.

The post-amplifier of the OPT-1250xxxx also includes a Signal Detect circuit that provides a PECL or TTL logic-Low output when an unusable optical signal level is detected. (see order information)

The OPT-1250xxxx transceiver is a Class 1 eye safety product. The optical power levels, under normal operation, are at eye safe level.

### Applications

- Gigabit Ethernet/Fast Ethernet
- Switched backplane applications

### Performance

#### OPT-1250AxFxx:

- 850nm VCSEL, up to 500m in 50/125  $\mu$  m MMF
- 850nm VCSEL, up to 220m in 62.5/125  $\mu$  m MMF

#### OPT-1250B211x:

- 1310nm FP laser, Data Link up to 5km in 9/125 $\mu$  m SMF

#### OPT-1250BxQxx:

- 1310nm FP laser, Data Link up to 10km in 9/125 $\mu$  m SMF
- 1310nm FP laser, up to 550m in 50/125  $\mu$  m MMF
- 1310nm FP laser, up to 550m in 62.5/125  $\mu$  m MMF

**Absolute Maximum Ratings**

Parameter	Symbol	Min.	Typ.	Max.	Unit	Note
Storage Temperature	T <sub>S</sub>	-40		85	°C	
Lead Soldering Temperature	T <sub>SOLD</sub>			260	°C	
Lead Soldering Time	t <sub>SOLD</sub>			10	sec.	
Supply Voltage	V <sub>CC</sub>	0		6	V	

**Recommended Operating Conditions**

Parameter	Symbol	Min.	Typ.	Max.	Unit	Note
Ambient Operating Temperature	T <sub>A</sub>	0		70	°C	1
Supply Voltage	V <sub>CC</sub>				V	
OPT-1250x1xx		4.75		5.25		
OPT-1250x2xx, OPT-1250x4xx		3.135		3.465		

Note: See ordering information for detail

**Electrical Characteristics**

(At recommended ambient operating temperature, T<sub>A</sub> and supply voltage, V<sub>CC</sub>)

Parameter	Symbol	Min.	Typ.	Max.	Unit	Note
Total Supply Current	I <sub>CC</sub>			300	mA	
<b>Transmitter</b>						
Transmitter Data Input Voltage-Low	V <sub>IL</sub> -V <sub>CC</sub>	-1.810		-1.475	V	1
Transmitter Data Input Voltage-High	V <sub>IH</sub> -V <sub>CC</sub>	-1.165		-0.880	V	1
Transmitter Differential Input Voltage	V <sub>DT</sub>	0.3		1.6	V	2
<b>Receiver</b>						
Data Output Voltage-Low	V <sub>OL</sub> -V <sub>CC</sub>	-1.95		-1.62	V	1
Data Output Voltage-High	V <sub>OH</sub> -V <sub>CC</sub>	-1.045		-0.74	V	1
Receiver Differential Output Voltage	V <sub>DR</sub>	0.5	0.7	1.2	V	2
Output Data Rise/Fall Time	t <sub>r</sub> /t <sub>f</sub>			0.4	ns	3
PECL SD Output						
LOW level output voltage	V <sub>SDH</sub> -V <sub>CC</sub>	-1.84		-1.60	V	4
HIGH level output voltage	V <sub>SDL</sub> -V <sub>CC</sub>	-1.1		-0.9		
TTL SD Output						
LOW level output voltage	V <sub>SDH</sub>	2		V <sub>CC</sub>	V	5
HIGH level output voltage	V <sub>SDL</sub>	0		0.8		

**Notes:**

- For OPT-1250A1F1x, OPT-1250A4F1x, OPT-1250B2I1x, OPT-1250B2Q1x and OPT-1250B1Q1x.
- For OPT-1250A2F2x and OPT-1250B4Q2x.
- These are 20%~80% values
- For OPT-1250A1F1x, OPT-1250A2F2x, OPT-1250B2I1x, OPT-1250B1Q1x and OPT-1250B2Q1x
- For OPT-1250A4F1x and OPT-1250B4Q2x

**Single Mode Transceiver (OPT-1250B2I1x, OPT-1250B1Q1x, OPT-1250B2Q1x, OPT-1250B4Q2x)**

(At recommended ambient operating temperature,  $T_A$  and supply voltage,  $V_{CC}$ ; Data Rate=1.25Gb/sec, PRBS= $2^7-1$  NRZ, 9/125um SMF)

Parameter	Symbol	Min.	Typ.	Max.	Unit	Note
<b>Transmitter</b>						
Output Optical Power (Avg.) OPT-1250BxIx OPT-1250BxQx	$P_O$	-12 -9.5		-3 -3	dBm	
Optical Extinction Ratio	ER	9			dB	
Center Wavelength	c	1270	1310	1355	nm	
Spectral Width (RMS)				2.8	nm	
Optical Rise/Fall time	$t_r/t_f$			0.26	ns	1
Relative Intensity Noise	RIN			-120	dB/Hz	
Output Eye	Complies with the IEEE 802.3z/D2 specification, and is class 1 laser eye safety					
<b>Receiver</b>						
Sensitivity (Avg.)	$P_{IN}$			-19	dBm	2
Input Optical Wavelength			1310		nm	
Signal Detect-Asserted (Avg.)	$P_A$			-19	dBm	
Signal Detect-De-asserted (Avg.)	$P_D$	-35			dBm	
Signal Detect-Hysteresis	$P_A-P_D$	0.5			dB	
Receiver saturation power	$P_{SAT}$	-3			dBm	

**Notes:**

- 6. These are 20%~80% values
- 7. The sensitivity is provided at a BER of  $1 \times 10^{-10}$  or better with an input signal consisting of 1250Mb/s,  $2^7-1$  PRBS.

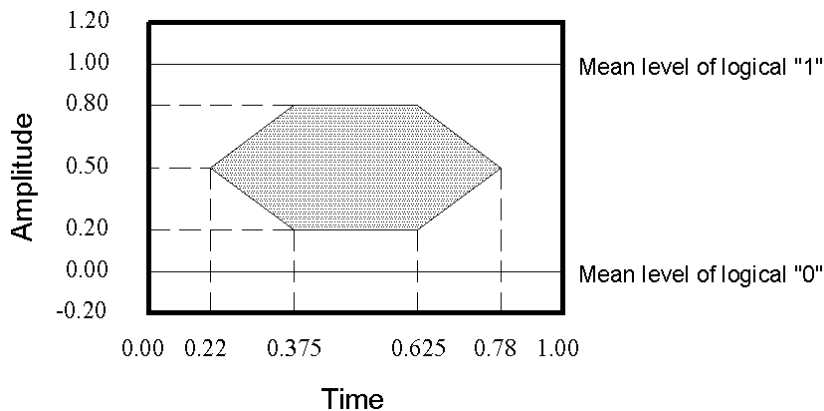

**Mask of the eye diagram for the optical transmit signal**

**Multi-Mode Series Transceiver (OPT-1250A1F1x, OPT-1250A2F2x, OPT-1250A4F1x)**

(At recommended ambient operating temperature,  $T_A$  and supply voltage,  $V_{CC}$ ; Data Rate=1.25Gb/sec, PRBS= $2^7-1$  NRZ, 62.5/125um MMF)

Parameter	Symbol	Min.	Typ.	Max.	Unit	Note
<b>Transmitter</b>						
Output Optical Power (Avg.)	$P_O$	-9.5		-4	dBm	
Optical Extinction Ratio	ER	9			dB	
Center Wavelength	$\lambda_c$	830	850	860	nm	
Spectral Width (RMS)				0.85	nm	
Optical Rise/Fall time	$t_r/t_f$			0.26	ns	1
Relative Intensity Noise	RIN			-117	dB/Hz	
Output Eye	Complies with the IEEE 802.3z/D2 specification, and is class 1 laser eye safety					
<b>Receiver</b>						
Sensitivity (Avg.)	$P_{IN}$			-17	dBm	2
Input Optical Wavelength			850		nm	
Signal Detect-Asserted (Avg.)	$P_A$			-17	dBm	
Signal Detect-De-asserted (Avg.)	$P_D$	-30			dBm	
Signal Detect-Hysteresis	$P_A-P_D$	0.5			dB	
Receiver saturation power	$P_{SAT}$	-4			dBm	

**Notes:**

- 8. These are 20%~80% values
- 9. The sensitivity is provided at a BER of  $1 \times 10^{-10}$  or better with an input signal consisting of 1250Mb/s,  $2^7-1$  PRBS.

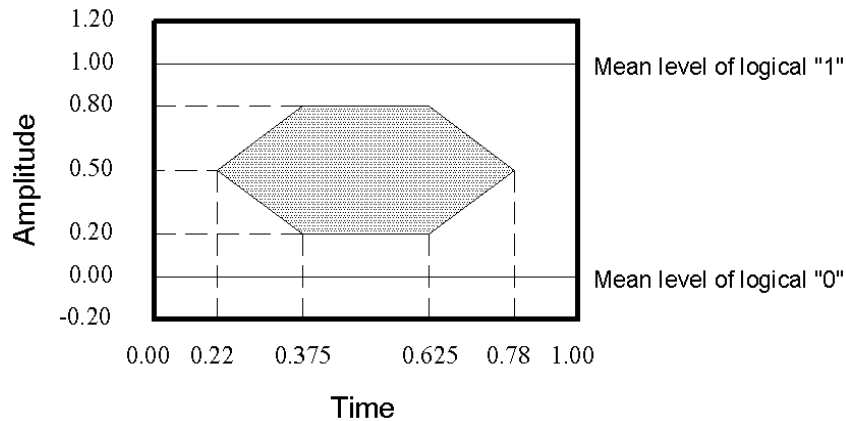

**Mask of the eye diagram for the optical transmit signal**

**Pin Out Table**

<b>PIN</b>	<b>Symbol</b>	<b>Functional description</b>
1	GND	Receiver Signal Ground
2	RD (+)	Receiver Data Out (LVPECL)
3	RD (-)	Receiver Data Out Bar (LVPECL)
4	SD	Receiver Signal Detect (LVPECL or TTL)
5	VccR	Receiver Power Supply,
6	VccT	Transmitter Power Supply
7	TD (-)	Transmitter Data In Bar (LVPECL)
8	TD (+)	Transmitter Data In (LVPECL)
9	GND	Transmitter Signal Ground

**Pin Descriptions:****Pin 1 Receiver Signal Ground, GND**

Directly connect these pins to the ground plane.

**Pin 2 Receiver Data Out (LVPECL), RD (+)**

Receiver Data output (LVPECL), RD (+).

**Pin 3 Receiver Data Out Bar (LVPECL), RD (-)**

Receiver Data output (LVPECL), RD (-).

**Pin 4 Receiver Signal Detect (LVPECL/TTL), SD**

PECL/TTL logic family. Normal Operation: Logic "1" Output

Fault Condition: Logic"0" Output.

**Pin 5 Receiver Power Supply, VccR**

Provide +3.3/5V dc power supply.

**Pin 6 Transmitter Power Supply, VccT**

Provide +3.3/5V dc power supply.

**Pin 7 Transmitter Data In Bar (LVPECL), TD (-)**

Transmitter Data Input (LVPECL), TD (-)

**Pin 8 Transmitter Data In (LVPECL), TD (+)**

Transmitter Data Input (LVPECL), TD (+)

**Pin 9 Transmitter Signal Ground, GND**

Directly connect these pins to the ground plane.

**Recommend Circuit Schematic for Internal DC Coupled Transceivers**

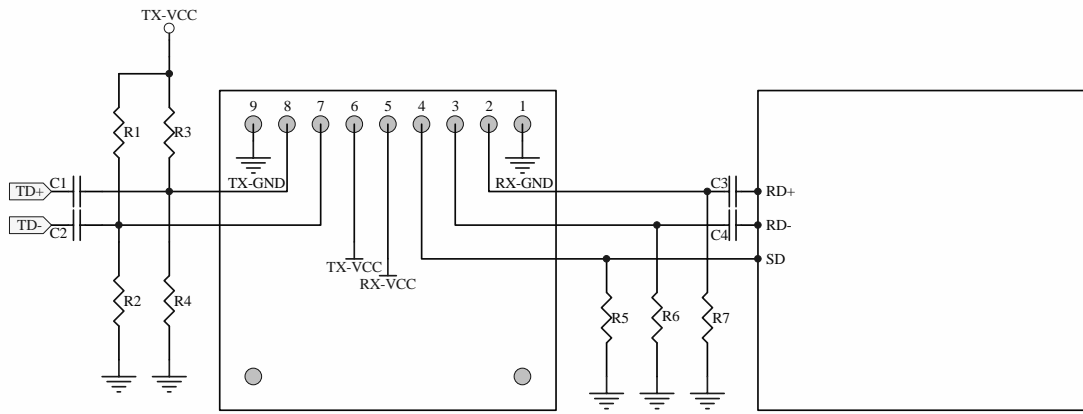

- Transceiver Top View**
- R1=R3=82 Ohm (3.3V), 68 Ohm (5V)
  - R2=R4=130 Ohm (3.3V), 191 Ohm (5V)
  - R5=270 Ohm (3.3V, PECL), 510 Ohm (5V, PECL)
  - NC (TTL)
  - R6=R7=274 Ohm (5V)
  - C1=C2=C3=C4=C6=C8=100 nF
  - C5=100 uF
  - C7=C9=10 uF
  - L1=L2=1 uH or ferrite inductor

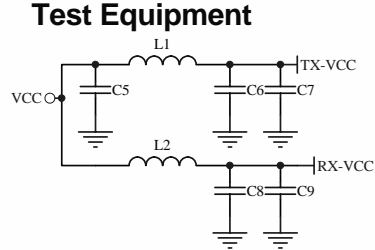

**Recommend Circuit Schematic for Internal AC Coupled Transceivers**

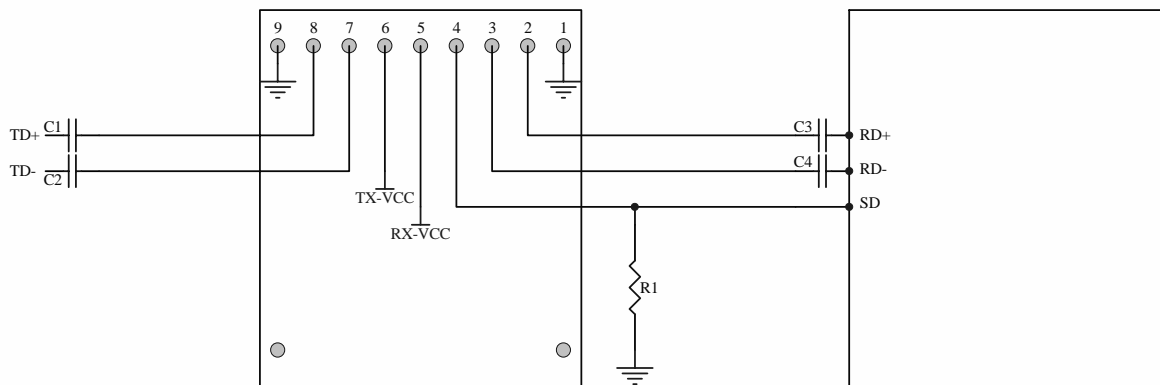

- Transceiver Top View**
- R1=270 Ohm(3.3V, PECL), 510 Ohm (5V, PECL)
  - NC(TTL)
  - C1=C2=C3=C4=C6=C8=100 nF
  - C5=100 uF
  - C7=C9=10 uF
  - L1=L2=1 uH or ferrite inductor

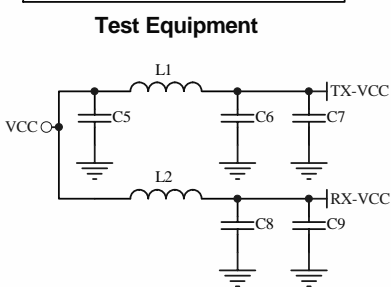

Package Outline Drawing (without shielding)

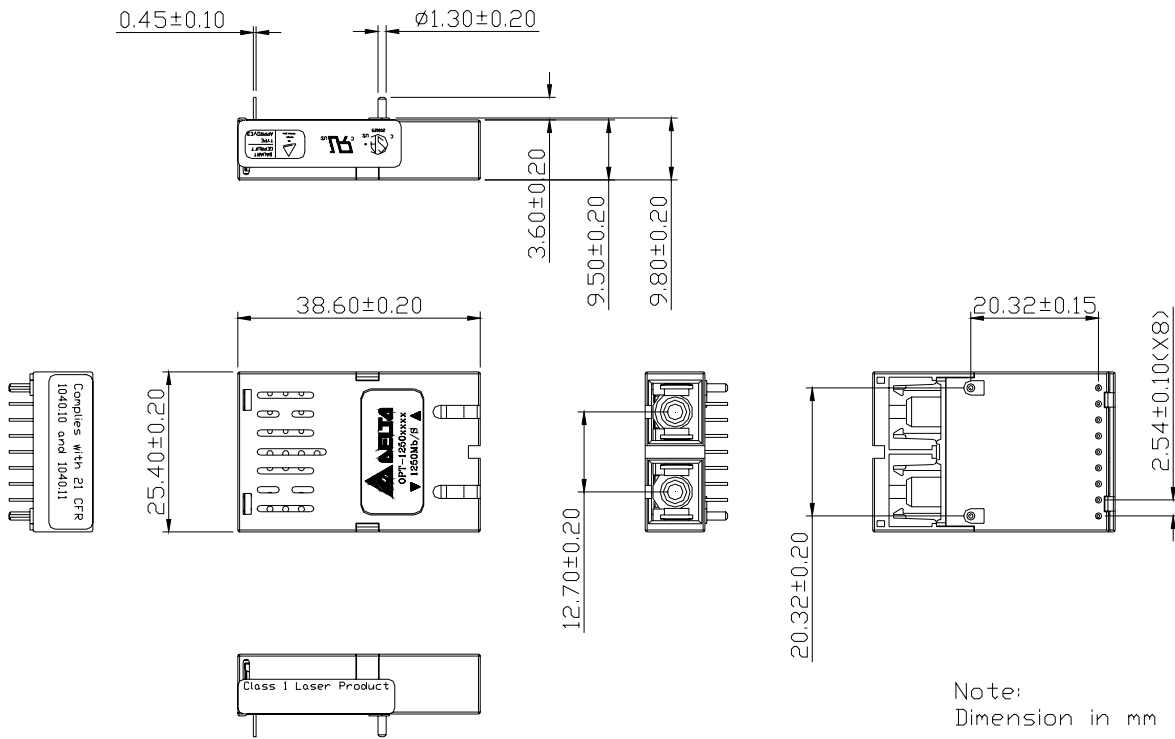

Package Outline Drawing (A type shielding)

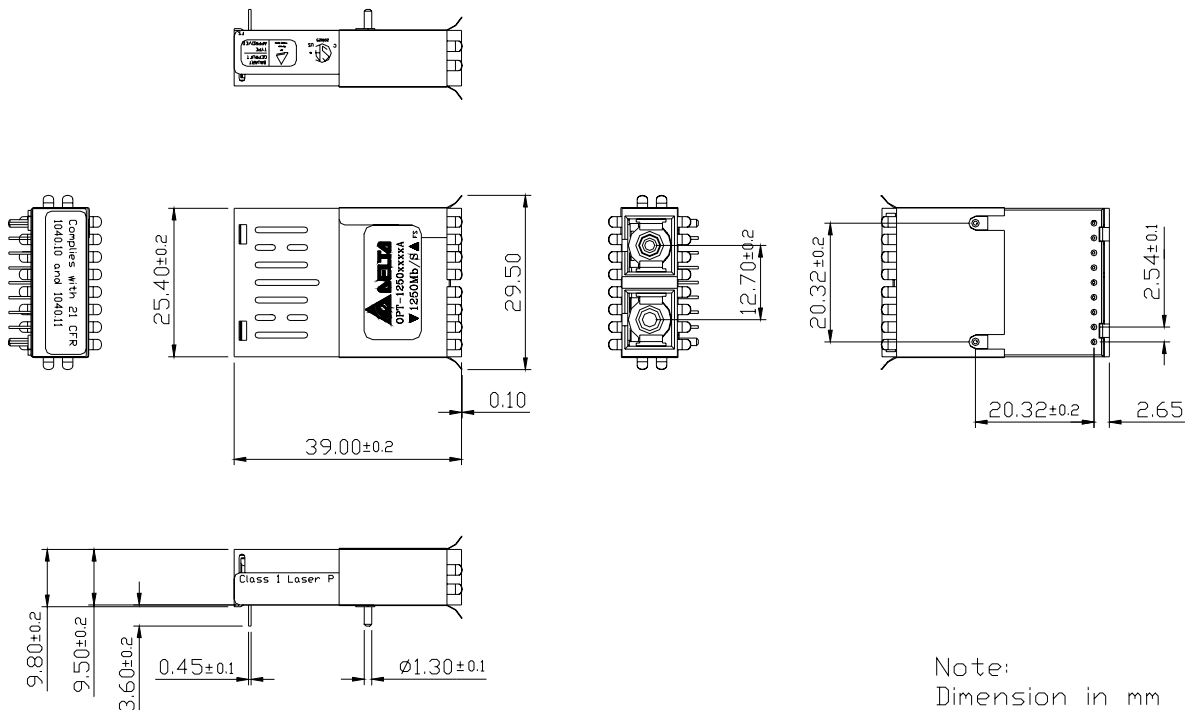

Package Outline Drawing (B type shielding)

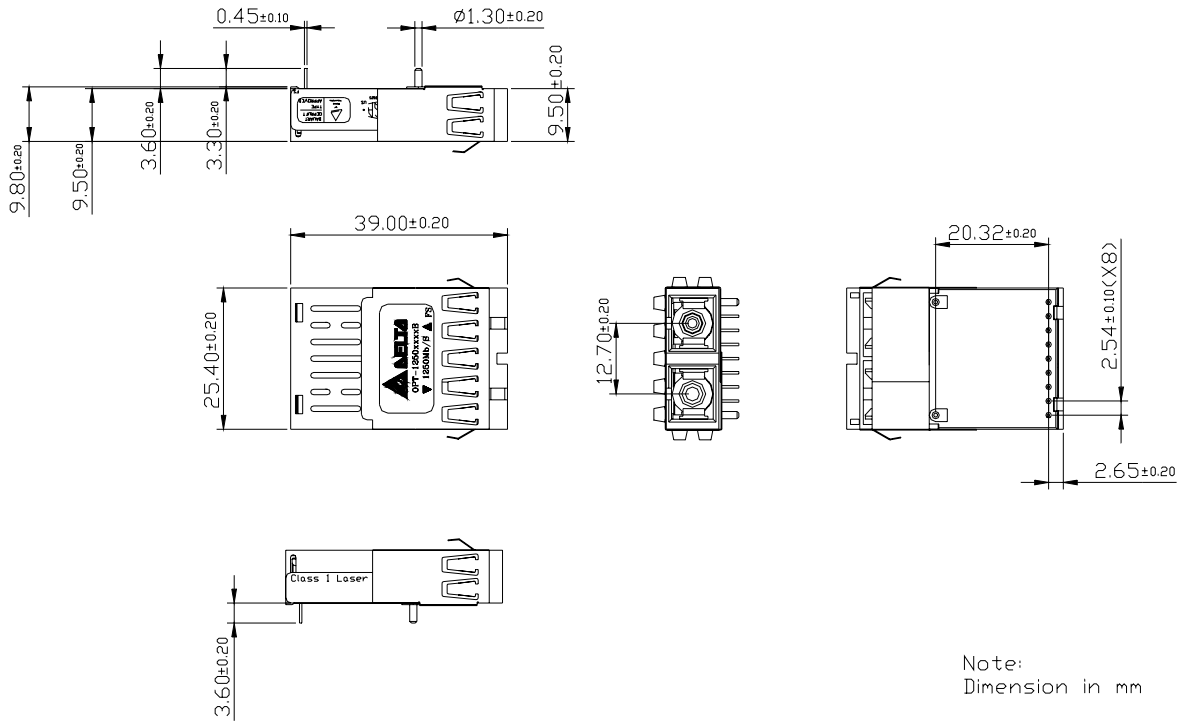

Package Outline Drawing (C type shielding)

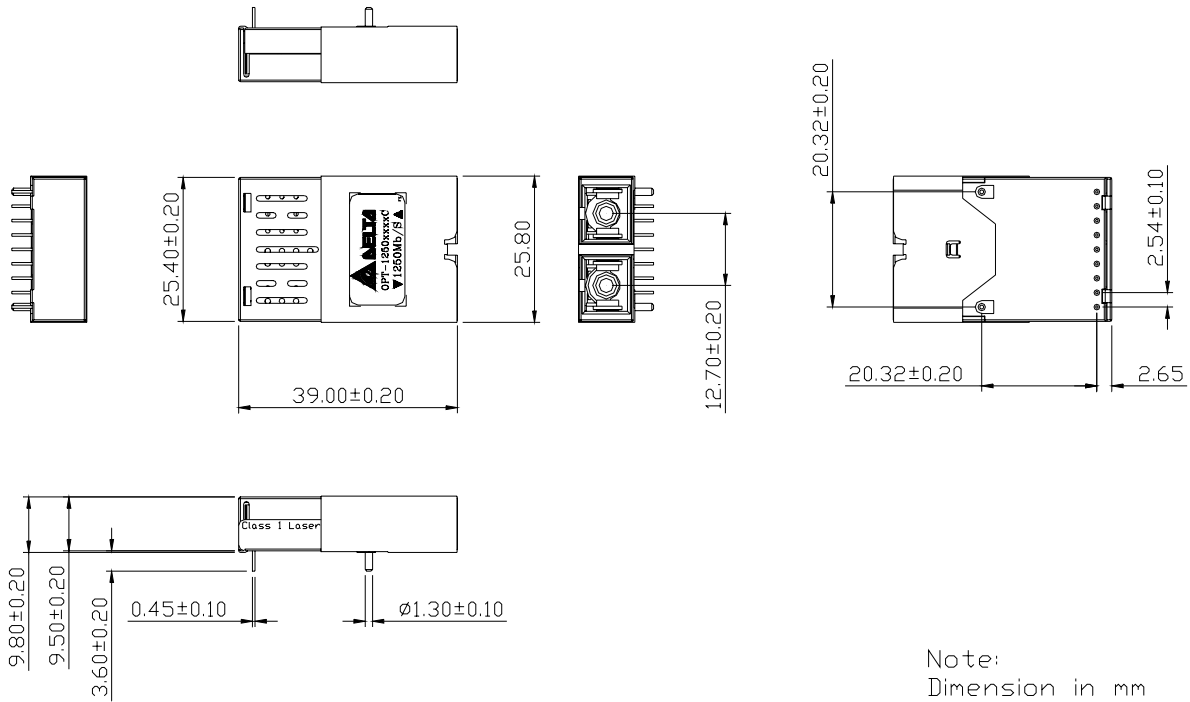



**Regulatory Compliance**

Feature	Reference	Performance
Electromagnetic Interference (EMI)	FCC Class B EN 55022 Class B (CISPR 22A)	(1) Satisfied with electrical characteristics of product spec.  (2) No physical damage
Radio Frequency Electromagnetic Field	EN 61000-4-3 IEC 1000-4-3	
Electrostatic Discharge to the Duplex LC Receptacle	EN 61000-4-2 IEC 1000-4-2 IEC 801.2	
Electrostatic Discharge to the Electrical Pins	MIL-STD-883E Method 3015.7	
Eye Safety	US FDA CDRH AEL Class 1  EN 60950: 2000 EN 60825-1: 1994+A11+A2 EN 60825-2: 2000	CDRH File # 0321539-00  TUV Certificate No. R50032471
Component Recognition	Underwriters Laboratories and Canadian Standards Association Joint Component Recognition for Information Technology Equipment Including Electrical Business Equipment	UL File # E239394

## Ordering information

OPT- 1250X<sub>1</sub>X<sub>2</sub>X<sub>3</sub>X<sub>4</sub>X<sub>5</sub>X<sub>6</sub>X<sub>7</sub>

**X<sub>1</sub>: Fiber**

**A:** Multi-mode 850nm  
**B:** Single-mode 1310nm

**X<sub>2</sub>: Power Supply Voltage and SD Level**

**1:** 5.0V, PECL SD Level  
**2:** 3.3V, PECL SD Level  
**4:** 3.3V, TTL SD Level

**X<sub>3</sub>: Distance**

**F:** 500m, 50/125 μ m MMF  
**I:** 5km, 9/125 μ m SMF  
**Q:** 10km, 9/125 μ m SMF

**X<sub>4</sub>: Data Coupling**

**1:** 1x9SC DC/DC  
**2:** 1x9SC AC/AC

**X<sub>5</sub>:**

**RoHS Compliant**  
**Blank:** Non-RoHS Compliant  
**R:** RoHS Compliant

**X<sub>6</sub>: Shielding Type**

**Blank:** Plastic housing  
**A:** A type shielding  
**B:** B type shielding  
**C:** C type shielding

**X<sub>7</sub>: Temperature**

**Blank:** 0 to +70 degree C  
**H:** -10 to + 85 degree C