

3 Watt Cellular T/R and Antenna Changeover Switch, DC - 3.0 GHz



Features

- Low Cost Plastic SOT-26 Package
- Low Insertion Loss <0.6dB @ 1900 MHz
- Low Power Consumption <20µA @ +3V
- Very High Intercept Point: 53 dBm IP₃
- Both Positive and Negative 2.5 to 8 V Control
- For CDMA, W-CDMA, TDMA, GSM, PCS and DCS Applications

Description

M/A-COM's SW-425 is a GaAs monolithic switch in a low cost SOT-26 surface mount plastic package. The SW-425 is ideally suited for applications where very low power consumption (<10µA@5V), low intermodulation products and very small size are required. Typical applications include Internal/External antenna select switch for portable telephones and data radios. In addition, because of its low loss, good isolation and inherent speed, the SW-425 can be used as a conventional T/R switch or as an antenna diversity switch. The SW-425 can be used in power applications up to 3 watts in systems such as cellular PCS, CDMA, W-CDMA, TDMA, GSM and other analog/digital wireless communications systems.

The SW-425 is fabricated using a new 0.5 micron gate length GaAs PHEMT process. The process features full chip passivation for increased performance and reliability.

Electrical Specifications T_A = 25°C

Parameter	Test Conditions	Units	Min.	Typ.	Max.
Insertion Loss	DC - 1 GHz	dB		0.4	0.5
Insertion Loss	1 - 2 GHz	dB		0.55	0.65
Insertion Loss	2 - 3 GHz	dB		0.7	0.8
Isolation	DC - 1 GHz	dB	18	20	
Isolation	1 - 2 GHz	dB	13	15	
Isolation	2 - 3 GHz	dB	10	12	
VSWR	DC - 3 GHz			1.2:1	1.4:1
P _{1dB} (3V supply)	500 MHz - 3 GHz	dBm	32	34	
P _{1dB} (5V supply)	500 MHz - 3 GHz	dBm	34	36	
Input IP ₂	2-Tone, 5 MHz spacing, 0.9 GHz +10 dBm (+13 dBm total) V _{CTL} =3V	dBm	62	70	
Input IP ₃	2-Tone, 5 MHz spacing, 0.9 GHz +10 dBm (+13 dBm total) V _{CTL} =3V	dBm	48	53	
Harmonics	2 nd 3 rd	Pin 30 dBm V _{CTL} = 3V	65 45	70 48	
Harmonics	2 nd 3 rd	Pin 33 dBm V _{CTL} = 5V	65 65	75 75	
T _{rise} , T _{fall}	10% to 90% RF, 90% to 10% RF	nS		60	
T _{on} , T _{off}	50% Control to 90% RF, Control to 10% RF	nS		20	
Transients	In-Band	mV		20	
Gate Leakage Current	V _{CTL} = 3 V	µA		10	20

SOT-26 Plastic Package

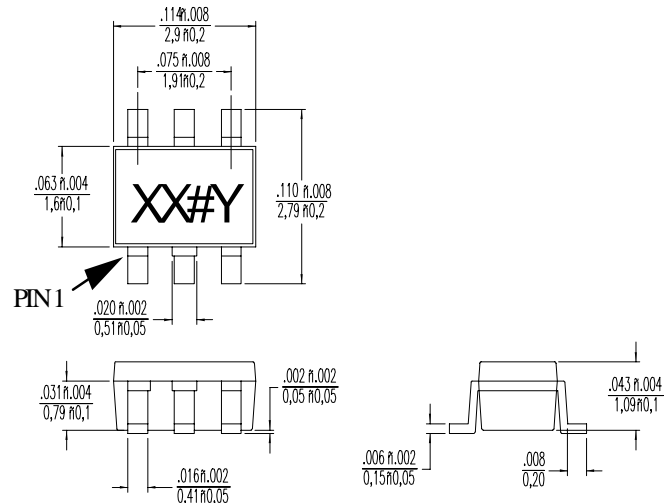

Ordering Information

Part Number	Package
SW-425 PIN	SOT-26 Plastic Package
SW-425TR	Forward Tape and Reel ¹
SW-425RTR	Reverse Tape and Reel ¹

1. Reference Application Note M513 for reel size information.

Absolute Maximum Ratings¹

Parameter	Absolute Maximum
Max. Input Power (0.5 - 3.0 GHz)	
3 V Control	+36 dBm
5 V Control	+38 dBm
Operating Temperature	-40°C to +85°C
Storage Temperature	-65°C to +150°C

1. Exceeding any one or combination of these limits may cause permanent damage.

Functional Diagram

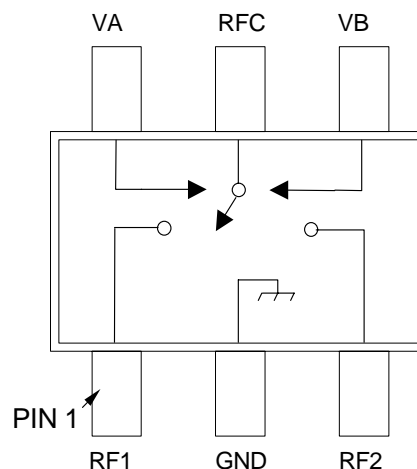

Truth Table

Mode (Control)	Control A	Control B	RFC - RF1	RFC - RF2
Positive ¹	0±0.2V	+2.5 to +8V	Off	On
	+2.5 to +8V	0±0.2V	On	Off
Postitive/ Negative ^{1,2}	-Vc±0.2V	+Vc	Off	On
	+Vc	-Vc±0.2V	On	Off
Negative ³	0±0.2V	-2.5V to -8V	On	Off
	-2.5V to -8V	0±0.2V	Off	On

- External DC blocking capacitors are required on all RF ports. 39pF capacitors used for positive control voltage.
- $|-V_{CTL}|, V_{CTL} \leq 8V$
- If negative control is used, DC blocking capacitors are not required on RF Ports.

PIN Configuration

PIN No.	Function	Description
1	RF1	RF in/out
2	GND	RF Ground
3	RF2	RF in/out
4	VB	V Control B
5	RFC	RF COMMON
6	VA	V Control A

Handling Procedures

The following precautions should be observed to avoid damage:

Static Sensitivity

Gallium arsenide Integrated Circuits are ESD sensitive and can be damaged by static electricity. Proper ESD techniques should be used when handling these devices.

Typical Performance Curves

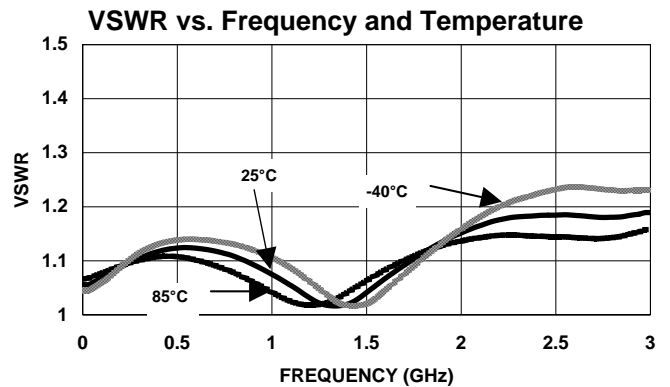
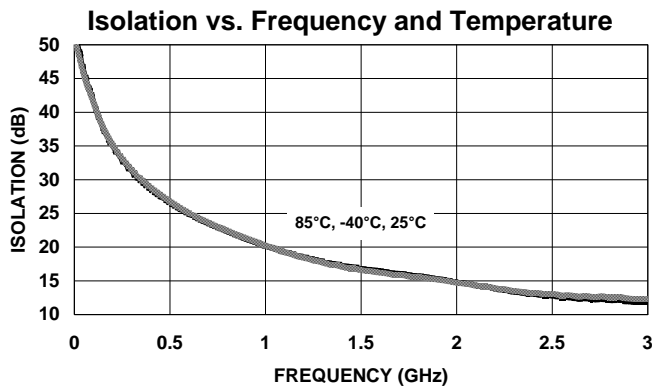
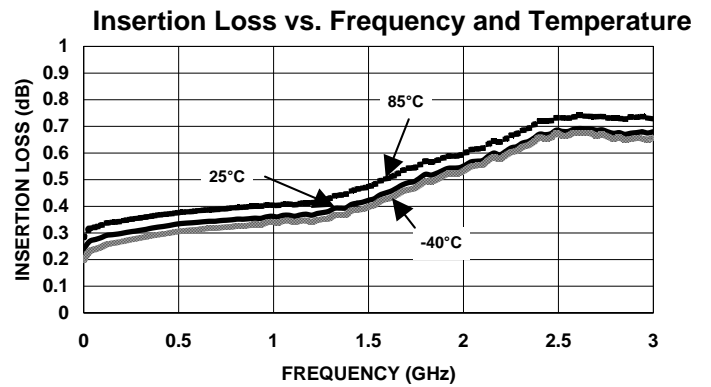
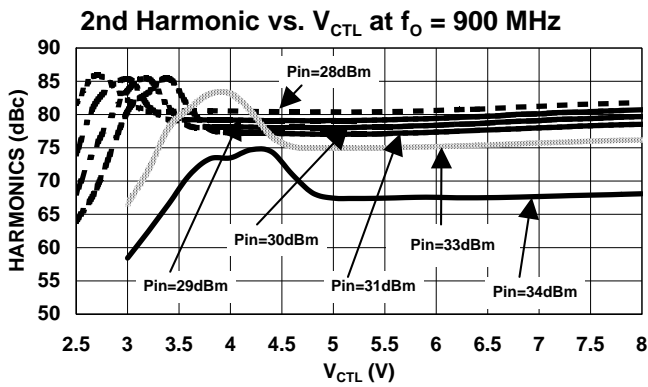
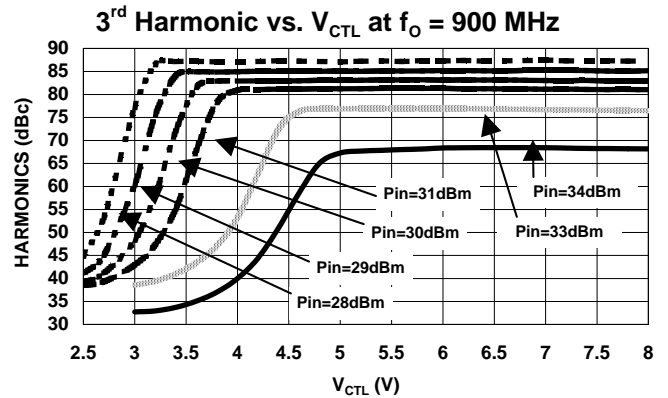
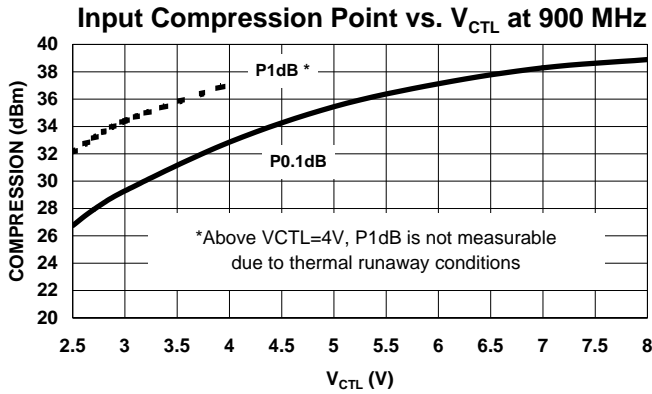

V2.00