

KLM - 128CA - 16B

This module designed for light emitting display device. Organize with 16 x 32 matrix combination with 512 of DUAL(Red, Green)Chip LEDs, for indoor use.

FEATURES

- Active display size : 128mm x256mm
- Dot size : ϕ 6.5
- Dot pitch : 8mm
- Display color : RED, GREEN, AMBER(Mixed color)
- Duty rate : 1/16
- Dot matrix : 512(16 x16)
- Weight : 130g(Typ.)

MAXIMUM RATINGS

(Ta=25)

ITEM	SYMBOL	RATING	UNIT	COND.
Power dissipation	P _d	25	W	
Supply voltage(DRIVE)	V _{DD}	6	V	
Supply voltage(LED)	V _{LED}	6	V	
Logic input power	V _{in}	- 0.5 ~ V _{DD}	V	
Junction Temp.	T _J	115		
Operating Temp.	T _a	- 20 ~ + 65		
Storage Temp.	T _g	- 20 ~ + 70		

DIMENSIONS

(Unit : mm)

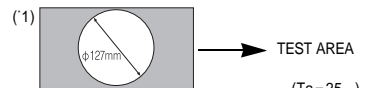
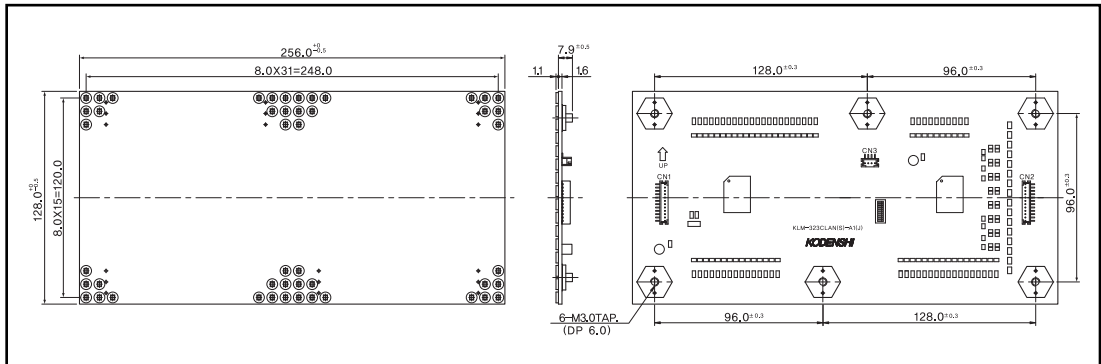

OPTICAL CHARACTERISTICS

(Ta=25)

ITEM	SYMBOL	CONDITION	MIN.	TYP.	MAX.	UNIT.
Bright - ness(16x 16)	GREEN	IV _g	-	100	-	cd/m ² · 1
	RED	IV _r	-	120	-	
	AMBER	IV _o	-	180	-	
Dot - Balance	GREEN	IVR _g	-	-	2	-
	RED	IVR _r	-	-	2	
	AMBER	IVR _o	-	-	2	
Emission Wavelength	GREEN	λ_p	-	570	-	nm
	RED	λ_p	-	660	-	
	AMBER	λ_p	-	-	-	
Spectrum half - band	GREEN	θ	-	30	-	nm
	RED	θ	-	40	-	

LED Dot Matrix

KLM - 128CA - 16B

ELECTRICAL CHARACTERISTICS(VOLTAGE CURRENT CHARACTERISTICS)

(Ta=25)

ITEM	SYMBOL	CONDITION	MIN.	TYP.	MAX.	UNIT.	
Supply voltage(LOGIC)	V _{DD}	-	4.75	5	5.25	V	
Supply voltage(LED)	V _{LED}	-	4.50	5	5.50	V	
Supply current(LOGIC)	I _{DD}	V _{DD} =5V	-	50.0	100.0	mA	
Supply current(LED)	GREEN	I _{LEDg}	Lighting - all '1'	-	-	2.4	A
	RED	I _{LEDr}		-	-	2.2	
	AMBER	I _{LEDo}		-	-	3.6	
Logic - input voltage LOW	V _{IL}	V _{LED} =5V	-	-	1.5	V	
Logic - input voltage HIGH	V _{IH}	V _{DD} =5V	3.5	-	-	V	

*2. V_{DD}=5V, V_{LED}=5V *Temperature condition of guarantee range for operating : -20~+65

*PULL UP

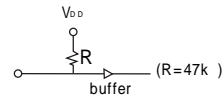

ELECTRICAL CHARACTERISTICS (CONNECTOR SPECIFICATION)

CLASSIFICATION	NAME	STANDARD	LENGTH	COMPANY	REMARK	
POWER CONN.	WAFER	B 4B - PH - SM3 - TB	-	KST	JST C/N	
INPUT SIGNAL CONN.	WAFER	B 12B - PH - SM3 - TB	-	KST	JST C/N	
OUTPUT SIGNAL CONN.	WAFER	B 12B - PH - SM3 - TB	-	KST	JST C/N	
ASSY	POWER	HARNESS	PHR - 4 - 200S	Option	KST	JST C/N
		HARNESS	PHR - 4 - 200R	Option	KST	JST C/N
	SIGNAL	HARNESS	PHR - 12 - 100	Option	KST	JST C/N

BLOCK DIAGRAM

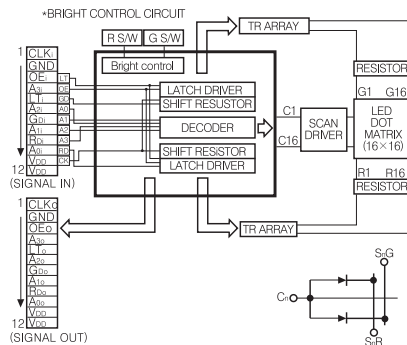

TIMING CHART

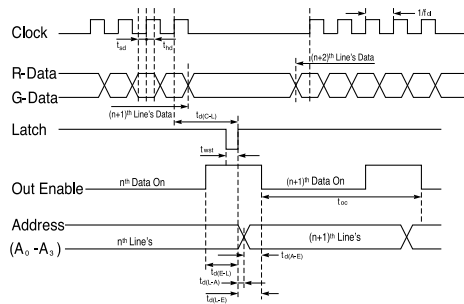

RECOMMENDED TIMING CONDITION

NO	ITEM	SYMBOL	MIN.	TYP.	MAX.	UNIT.
1	CLOCK FREQUENCY	f _{cl}	-	-	40	MHz
2	CLOCK CYCLE	1/f _{cl}	25	-	-	ns
3	CLOCK - LATCH TIME	t _{d(C-L)}	25	-	-	ns
4	LATCH PULSE WIDTH	t _{twst}	25	-	-	ns
5	ENABLE - LATCH TIME	t _{d(E-L)}	0	-	-	ns
6	DATA SETUP TIME	t _{sd}	6	-	-	ns
7	DATA HOLD TIME	t _{hd}	6	-	-	ns
8	ADDRESS - ENABLE TIME	t _{d(A-E)}	25	-	-	ns
9	LATCH - ADDRESS TIME	t _{d(L-A)}	0	-	-	ns
10	LATCH - ENABLE TIME	t _{d(L-E)}	0	-	-	ns
11	ON TIME	t _{oc}	-	-	1	ms