

## Keyboard/Mouse Port Interface

### Features

- Integrated network contains complete filter, solution and ESD protection diodes

### Applications

- EMI/RFI filter and ESD protection for keyboard and mouse ports

### Product Description

The signals from the keyboard/mouse controller contain high frequency EMI signals that must be reduced before the connector. Likewise, the signals from the keyboard/mouse controller must be protected from any possible external charges such as static electricity. The PACKBM provides filtering and pull-up termination of the keyboard and mouse signals as well as ESD protection.

### Electrical Schematic

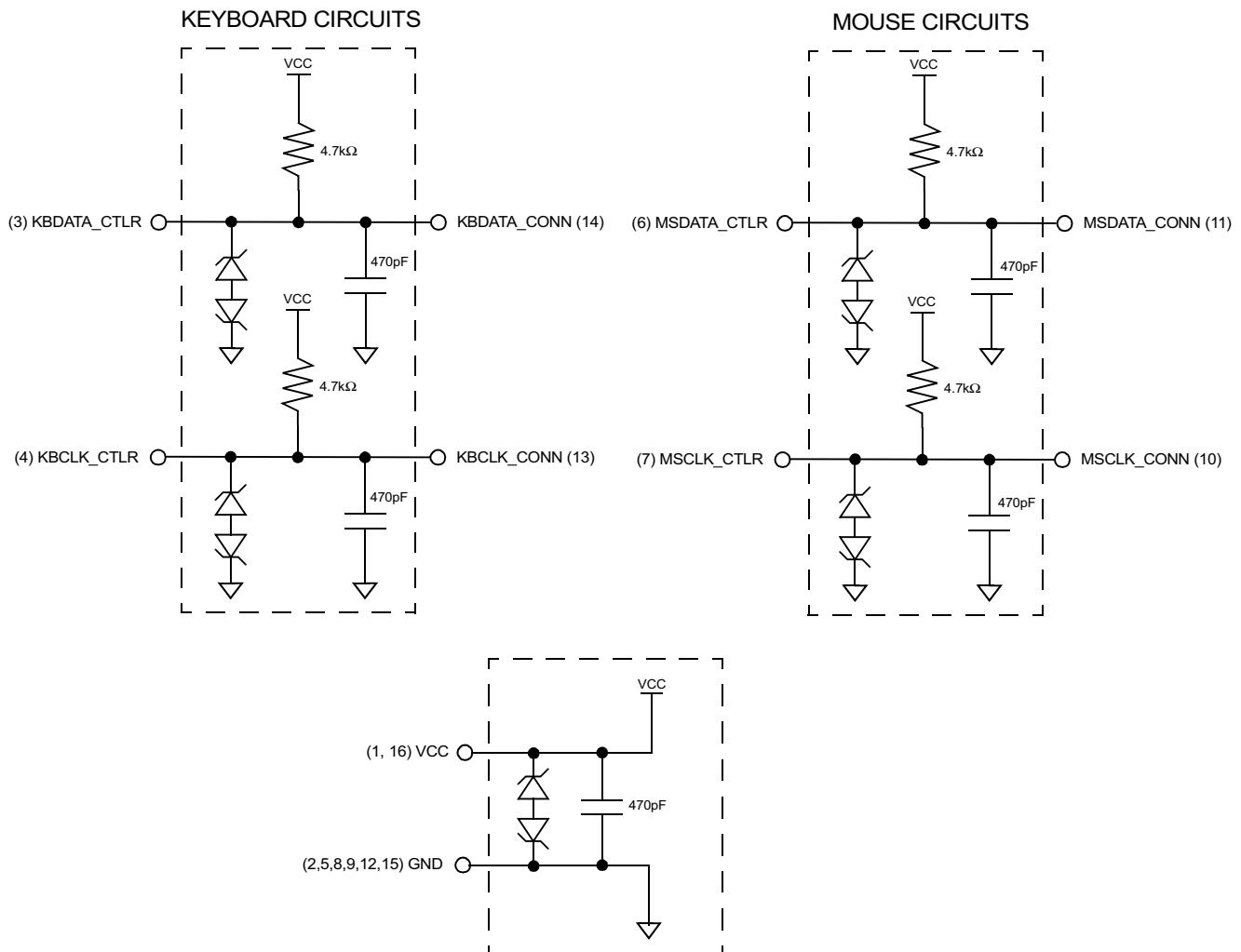



**PACKAGE / PINOUT DIAGRAM**

Top View

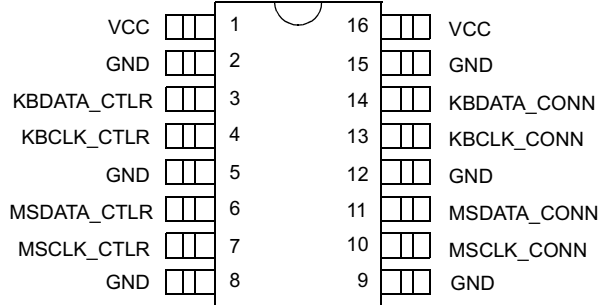

16-PIN QSOP

Note: This drawing is not to scale.

**PIN DESCRIPTIONS**

PIN	NAME	DESCRIPTION
1	VCC	Positive supply
2	GND	Negative supply
3	KBDATA_CTLR	Controller-side keyboard data channel
4	KBCLK_CTLR	Controller-side keyboard clock channel
5	GND	Negative supply
6	MSDATA_CTLR	Controller-side mouse data channel
7	MSCLK_CTLR	Controller-side mouse clock channel
8	GND	Negative supply
9	GND	Negative supply
10	MSCLK_CONN	Connector-side mouse clock channel
11	MSDATA_CONN	Connector-side mouse data channel
12	GND	Negative supply
13	KBCLK_CONN	Connector-side keyboard clock channel
14	KBDATA_CONN	Connector-side keyboard data channel
15	GND	Negative supply
16	VCC	Positive supply



## Ordering Information

PART NUMBERING INFORMATION			
Pins	Package	Ordering Part Number <sup>1</sup>	Part Marking
16	QSOP-16	PACKBMQ/R	PACKBMQ

Note 1: Parts are shipped in Tape & Reel form unless otherwise specified.

## Specifications

ABSOLUTE MAXIMUM RATINGS		
PARAMETER	RATING	UNITS
Storage Temperature Range	-65 to +150	°C

STANDARD OPERATING CONDITIONS		
PARAMETER	RATING	UNITS
Ambient Operating Temperature Range	-40 to +85	°C

ELECTRICAL OPERATING CHARACTERISTICS <sup>1</sup>						
SYMBOL	PARAMETER	CONDITIONS	MIN	TYP	MAX	UNITS
R	Resistance (10% Tolerance)		4.23	4.7	5.17	kΩ
C	Capacitance (20% Tolerance)		376	470	564	pF
V <sub>ESD</sub>	ESD Protection a) Peak Discharge Voltage at any I/O, Human Body Model per MIL-STD-883D, Method 3015 b) In-system protection, HBM c) In-system protection, IEC 1000-4-2, Level 2	Notes 2 & 3 Note 3 Notes 3 & 4	±4 ±8 ±4			kV kV kV
V <sub>CL</sub>	Clamping Voltage during ESD Discharge per MIL-STD-883D, Method 3015 +8kV Discharge -8kV Discharge	Note 2 & 3		30 -30		V V

Note 1: Unless otherwise specified, Electrical Operating Characteristics are guaranteed at T<sub>A</sub>=25°C.

Note 2: Human Body Model per MIL-STD-883, Method 3015, C<sub>Discharge</sub> = 100pF, R<sub>Discharge</sub> = 1.5 KW, pins 1 and 16 tied to 5V and pins 2, 5, 8, 9, 12, 15 tied to ground.

Note 3: Pins 2, 5, 8, 9, 12, 15 grounded, pins 1 and 16 tied to VCC, all other pins are open. ESD contact discharge between ground and pins 3, 4, 6, 7, 10, 11, 13, 14, one at a time.

Note 4: Standard IEC 1000-4-2 with C<sub>Discharge</sub> = 150pF, R<sub>Discharge</sub> = 330W, pins 1, 16 tied to 5V and pins 2, 5, 8, 9, 12, 15 tied to ground.

**Application Information**

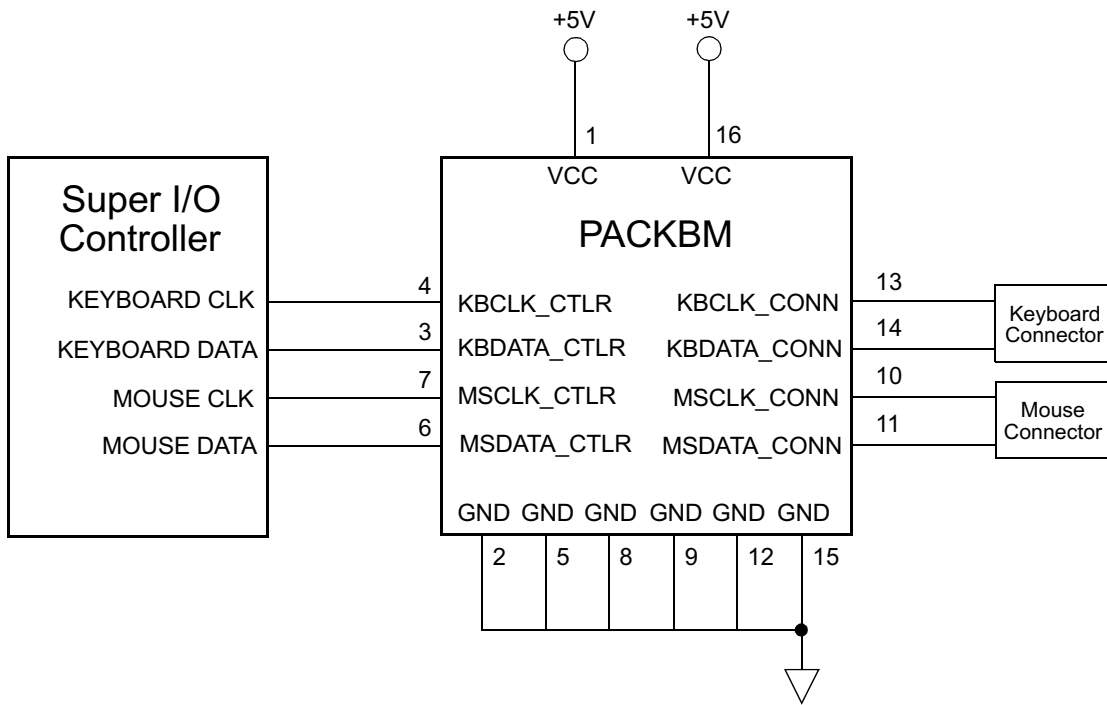

**Figure 1. Typical Application Circuit for the PACKBM.**

## Mechanical Details

### QSOP Mechanical Specifications

PACKBM devices are packaged in 16-pin QSOP packages. Dimensions are presented below.

For complete information on the QSOP-16 package, see the California Micro Devices QSOP Package Information document.

PACKAGE DIMENSIONS				
Package	QSOP (JEDEC name is SSOP)			
Pins	16			
Dimensions	Millimeters		Inches	
	Min	Max	Min	Max
<b>A</b>	1.35	1.75	0.053	0.069
<b>A1</b>	0.10	0.25	0.004	0.010
<b>B</b>	0.20	0.30	0.008	0.012
<b>C</b>	0.18	0.25	0.007	0.010
<b>D</b>	4.80	5.00	0.189	0.197
<b>E</b>	3.81	3.98	0.150	0.157
<b>e</b>	0.64 BSC		0.025 BSC	
<b>H</b>	5.79	6.19	0.228	0.244
<b>L</b>	0.40	1.27	0.016	0.050
<b># per tube</b>	100 pcs*			
<b># per tape and reel</b>	2500 pcs			
Controlling dimension: inches				

\* This is an approximate number which may vary.

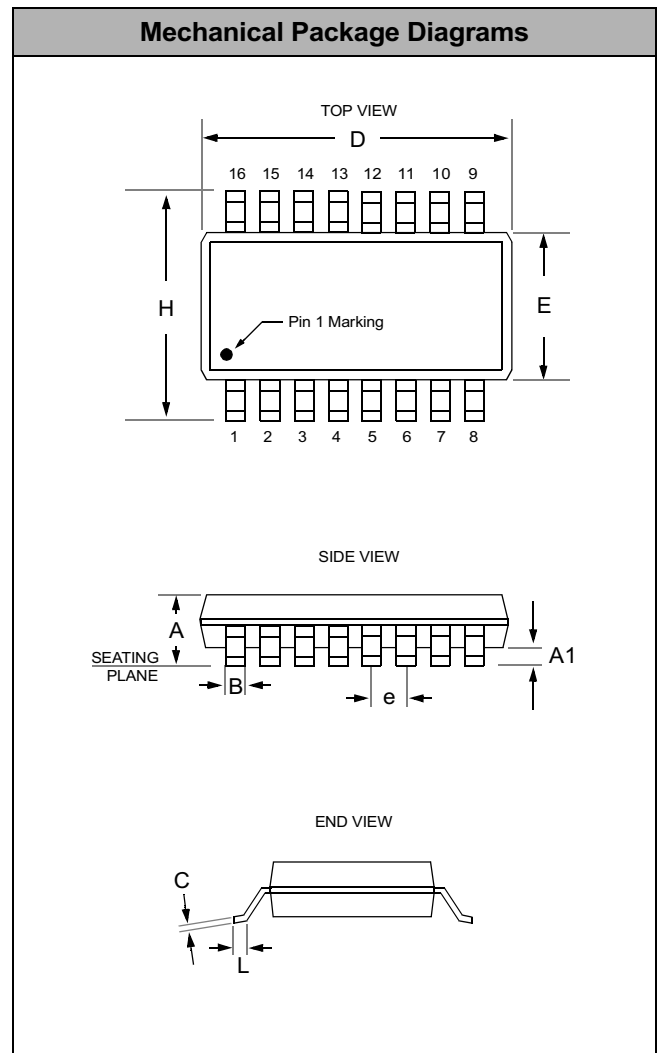

**Package Dimensions for QSOP-16**