

Document Title

64K x16 bit 1.8V Super Low Power Full CMOS Slow SRAM

Revision History

<u>Revision No</u>	<u>History</u>	<u>Draft Date</u>	<u>Remark</u>
03	Divide output load into a couple of factors - tCLZ,tOLZ,tBLZ,tCHZ,tOHZ,tBHZ,tWHZ,tOW - Others	Dec.16. 2000	Final
04	Add marking information Change AC Characteristic - tBLZ	Mar.24. 2002	Final

DESCRIPTION

The HY62SF16101C is a high speed, super low power and 1M bit full CMOS SRAM organized as 65,536 words by 16bit. The HY62SF16101C uses high performance full CMOS process technology and designed for high speed low power circuit technology. It is particularly well suited for used in high density low power system application. This device has a data retention mode that guarantees data to remain valid at a minimum power supply voltage of 1.2V.

FEATURES

- Fully static operation and Tri-state output
- TTL compatible inputs and outputs
- Battery backup(LL/SL-part)
 - . 1.2V(min) data retention
- Standard pin configuration
 - . 48 - FBGA

Product No.	Voltage (V)	Speed (ns)	Operation Current/Icc(mA)	Standby Current(uA)		Temperature (°C)
				LL	SL	
HY62SF16101C	1.7~2.3	85/100/120	3	2	1	0~70
HY62SF16101C-I	1.7~2.3	85/100/120	3	2	1	-40~85(I)

Note 1. Blank : Commercial, I : Industrial
 2. Current value is max.

PIN CONNECTION

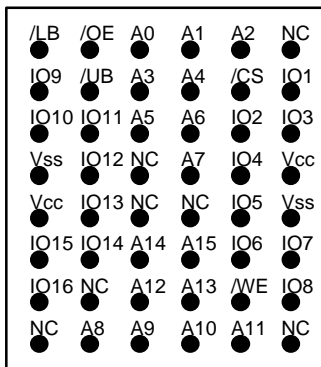

48-FBGA(Top View)

BLOCK DIAGRAM

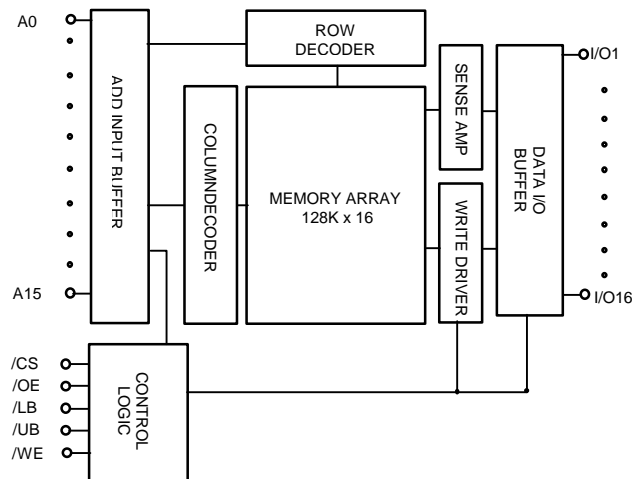

PIN DESCRIPTION

Pin Name	Pin Function	Pin Name	Pin Function
/CS	Chip Select	I/O1~I/O16	Data Inputs/Outputs
/WE	Write Enable	A0~A15	Address Inputs
/OE	Output Enable	Vcc	Power(1.7V~2.3V)
/LB	Low Byte Control(I/O1~I/O8)	Vss	Ground
/UB	Upper Byte Control(I/O9~I/O16)	NC	No Connection

ORDERING INFORMATION

Part No.	Speed	Power	Temp.	Package
HY62SF16101CLLF	85/100/120	LL-part		FBGA
HY62SF16101CSLF	85/100/120	SL-part		FBGA
HY62SF16101CLLF-I	85/100/120	LL-part	I.	FBGA
HY62SF16101CSLF-I	85/100/120	SL-part	I.	FBGA

Note 1. Blank : Commercial, I : Industrial

ABSOLUTE MAXIMUM RATING (1)

Symbol	Parameter	Rating	Unit	Remark
V _{IN} , V _{OUT}	Input/Output Voltage	-0.2 to 3.6	V	
V _{CC}	Power Supply	-0.2 to 4.6	V	
T _A	Operating Temperature	0 to 70	°C	HY62SF16101C
		-40 to 85	°C	HY62SF16101C-I
T _{STG}	Storage Temperature	-55 to 150	°C	
P _D	Power Dissipation	1.0	W	
T _{SD} SOLDER	Lead Soldering Temperature & Time	260•10	°C•sec	

Note

- Stresses greater than those listed under ABSOLUTE MAXIMUM RATINGS may cause permanent damage to the device. This is stress rating only and the functional operation of the device under these or any other conditions above those indicated in the operation of this specification is not implied. Exposure to the absolute maximum rating conditions for extended period may affect reliability.

TRUTH TABLE

/CS	/WE	/OE	/LB	/UB	Mode	I/O		Power
						I/O1~I/O8	I/O9~I/O16	
H	X	X	X	X	Deselected	High-Z	High-Z	Stand by
X	X	X	H	H	Deselected	High-Z	High-Z	Stand by
L	H	H	L	X	Output Disabled	High-Z	High-Z	Active
L	H	H	X	L	Output Disabled	High-Z	High-Z	Active
L	H	L	L	H	Read	DOUT	Hi-Z	Active
			H	L		Hi-Z	DOUT	
			L	L		DOUT	DOUT	
L	L	X	L	H	Write	DIN	Hi-Z	Active
			H	L		Hi-Z	DIN	
			L	L		DIN	DIN	

Note:

- H=V_{IH}, L=V_{IL}, X=don't care(V_{IH} or V_{IL})
- /UB, /LB(Upper, Lower Byte enable)
 These active LOW inputs allow individual bytes to be written or read.
 When /LB is LOW, data is written or read to the lower byte, I/O 1 -I/O 8.
 When /UB is LOW, data is written or read to the Upper byte, I/O 9 -I/O 16.

RCOMMENDED DC OPERATING CONDITION

Symbol	Parameter	Min.	Typ.	Max.	Unit
Vcc	Supply Voltage	1.7	1.8	2.3	V
Vss	Ground	0	0	0	V
V _{IH}	Input High Voltage	1.4	-	V _{cc} +0.3	V
V _{IL}	Input Low Voltage	-0.3(1)	-	0.4	V

Note : 1. V_{IL} = -1.5V for pulse width less than 30ns
 2. Undershoots are sampled and not 100% tested.

DC ELECTRICAL CHARACTERISTICS

V_{cc} = 1.7V~2.3V, T_A = 0°C to 70°C / -40°C to 85°C (I)

Sym	Parameter	Test Condition	Min.	Typ.	Max.	Unit	
I _{LI}	Input Leakage Current	V _{ss} ≤ V _{IN} ≤ V _{cc}	-1	-	1	uA	
I _{LO}	Output Leakage Current	V _{ss} ≤ V _{OUT} ≤ V _{cc} , /CS = V _{IH} or /OE = V _{IH} or /WE = V _{IL} , /UB = /LB = V _{IH}	-1	-	1	uA	
I _{cc}	Operating Power Supply Current	/CS = V _{IL} , V _{IN} = V _{IH} or V _{IL} , I _{I/O} = 0mA	-	-	3	mA	
I _{CC1}	Average Operating Current	/CS ≤ 0.2V, 1us Cycle Time, 100% Duty, I _{I/O} = 0mA, V _{IN} ≤ 0.2V	-	-	3	mA	
		/CS = V _{IL} , V _{IN} = V _{IH} or V _{IL} Cycle Time = Min. 100% Duty I _{I/O} = 0mA	-	-	25	mA	
I _{SB}	TTL Standby Current (TTL Input)	/CS = V _{IH} or /UB = /LB = V _{IH} , V _{IN} = V _{IH} or V _{IL}	-	-	0.3	mA	
I _{SB1}	Standby Current (CMOS Input)	/CS ≥ V _{cc} - 0.2V or /UB = /LB ≥ V _{cc} - 0.2V, V _{IN} ≥ V _{cc} - 0.2V or V _{IN} ≤ V _{ss} + 0.2V	SL	-	-	1	uA
			LL	-	0.5	2	uA
V _{OL}	Output Low Voltage	I _{OL} = 0.1mA	-	-	0.2	V	
V _{OH}	Output High Voltage	I _{OH} = -0.1mA	1.6	-	-	V	

Note : 1. Typical values are at V_{cc} = 1.8V, T_A = 25°C
 2. Typical values are sampled and not 100% tested.

CAPACITANCE

(Temp = 25°C, f = 1.0MHz)

Symbol	Parameter	Condition	Max.	Unit
C _{IN}	Input Capacitance(Add, /CS, /UB, /LB, /WE, /OE)	V _{IN} = 0V	8	pF
C _{OUT}	Output Capacitance(I/O)	V _{I/O} = 0V	10	pF

Note : These parameters are sampled and not 100% tested

AC CHARACTERISTICS
 $V_{CC} = 1.7\sim 2.3V$, $T_A = 0^{\circ}C$ to $70^{\circ}C$ / $-40^{\circ}C$ to $85^{\circ}C$ (I), unless otherwise specified

#	Symbol	Parameter	-85		-10		-12		Unit
			Min.	Max.	Min.	Max.	Min	Max.	
READ CYCLE									
1	tRC	Read Cycle Time	85	-	100	-	120	-	ns
2	tAA	Address Access Time	-	85	-	100	-	120	ns
3	tACS	Chip Select Access Time	-	85	-	100	-	120	ns
4	tOE	Output Enable to Output Valid	-	40	-	45	-	50	ns
5	tBA	/LB, /UB Access Time	-	85	-	100	-	120	ns
6	tCLZ	Chip Select to Output in Low Z	10	-	20	-	20	-	ns
7	tOLZ	Output Enable to Output in Low Z	5	-	5	-	10	-	ns
8	tBLZ	/LB, /UB Enable to Output in Low Z	10	-	10	-	20	-	ns
9	tCHZ	Chip Deselection to Output in High Z	0	30	0	30	0	40	ns
10	tOHZ	Out Disable to Output in High Z	0	30	0	30	0	40	ns
11	tBHZ	/LB, /UB Disable to Output in High Z	0	30	0	30	0	40	ns
12	tOH	Output Hold from Address Change	10	-	15	-	15	-	ns
WRITE CYCLE									
13	tWC	Write Cycle Time	85	-	100	-	120	-	ns
14	tCW	Chip Selection to End of Write	70	-	80	-	100	-	ns
15	tAW	Address Valid to End of Write	70	-	80	-	100	-	ns
16	tBW	/LB, /UB Valid to End of Write	70	-	80	-	100	-	ns
17	tAS	Address Set-up Time	0	-	0	-	0	-	ns
18	tWP	Write Pulse Width	55	-	75	-	85	-	ns
19	tWR	Write Recovery Time	0	-	0	-	0	-	ns
20	tWHZ	Write to Output in High Z	0	30	0	35	0	40	ns
21	tDW	Data to Write Time Overlap	35	-	45	-	50	-	ns
22	tDH	Data Hold from Write Time	0	-	0	-	0	-	ns
23	tOW	Output Active from End of Write	5	-	10	-	10	-	ns

AC TEST CONDITIONS
 $T_A = 0^{\circ}C$ to $70^{\circ}C$ / $-40^{\circ}C$ to $85^{\circ}C$ (I), unless otherwise specified

Parameter	Value	
Input Pulse Level	0.4V to 1.6V	
Input Rise and Fall Time	5ns	
Input and Output Timing Reference Level	0.9V	
Output Load	tCLZ,tOLZ,tBLZ,tCHZ,tOHZ,tBHZ,tWHZ,tOW	CL = 5pF + 1TTL Load
	Others	CL = 30pF + 1TTL Load

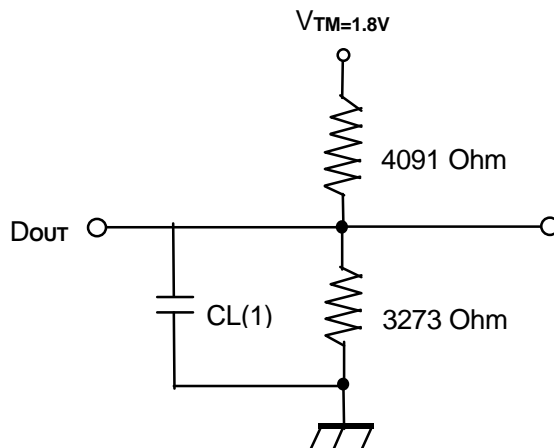
AC TEST LOADS

Note

1. Including jig and scope capacitance

TIMING DIAGRAM

READ CYCLE 1 (Note 1,4)

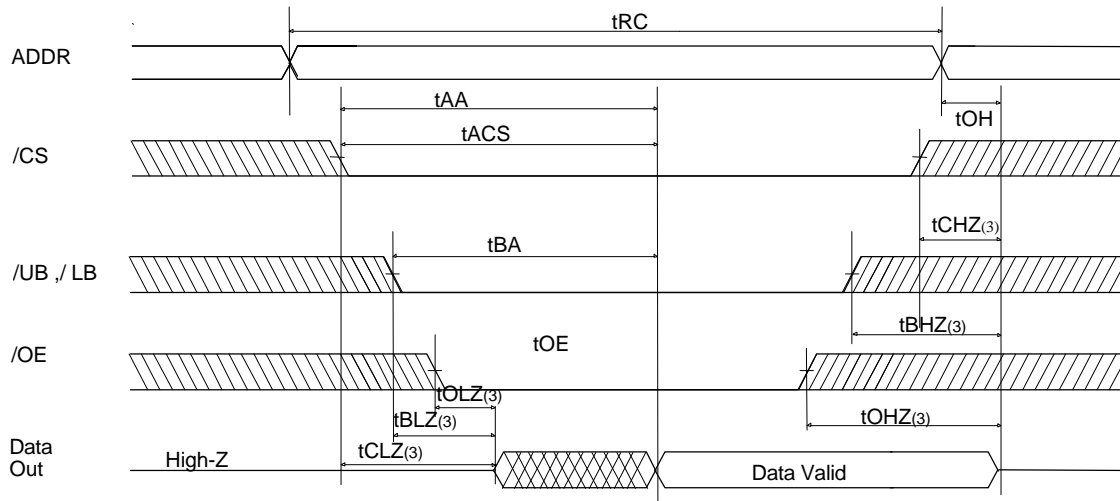

READ CYCLE 2 (Note 1,2,4)

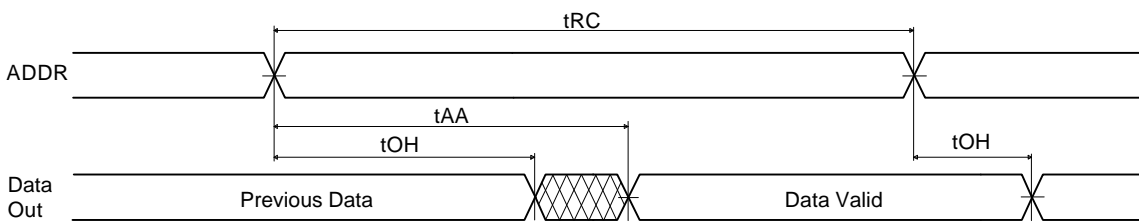

READ CYCLE 3 (Note 1,2,4)

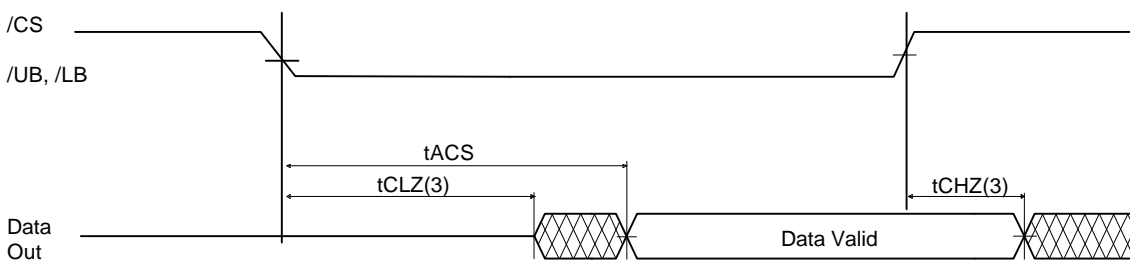

Notes:

1. A read occurs during the overlap of a low /OE, a high /WE, a low /CS1 and low /UB and/or /LB.
2. /OE = V_{IL}
3. Transition is measured ± 200mV from steady state voltage.
This parameter is sampled and not 100% tested.
4. /CS in high for the standby, low for active
/UB and /LB in high for the standby, low for active

WRITE CYCLE 1(1,4,8) (/WE Controlled)

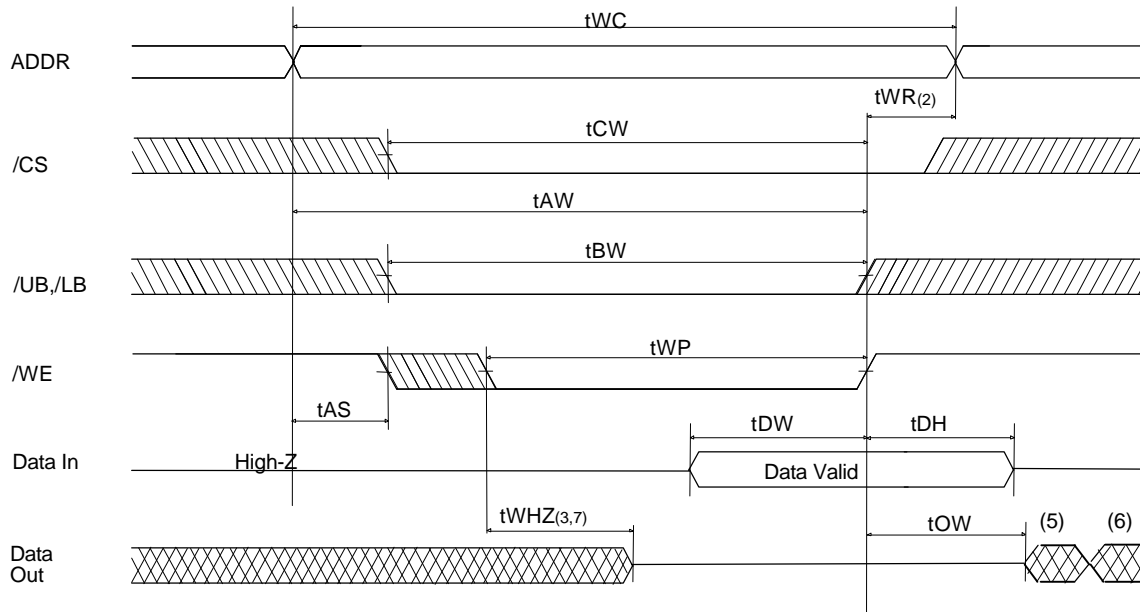

WRITE CYCLE 2 (Note 1,4,8) (/CS Controlled)

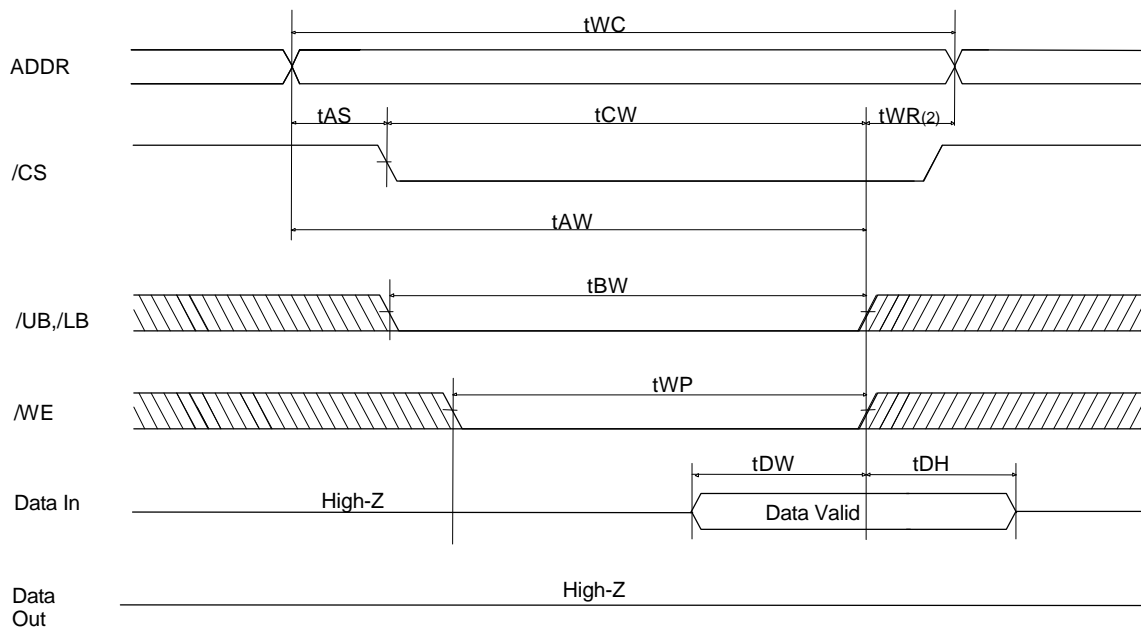

Notes:

1. A write occurs during the overlap of a low /WE, a low /CS1 and low /UB and/or /LB.
2. t_{WR} is measured from the earlier of /CS, /LB, /UB, or /WE going high to the end of write cycle.
3. During this period, I/O pins are in the output state so that the input signals of opposite phase to the output must not be applied.
4. If the /CS, /LB and /UB low transition occur simultaneously with the /WE low transition or after the /WE transition, outputs remain in a high impedance state.
5. Q(data out) is the same phase with the write data of this write cycle.
6. Q(data out) is the read data of the next address.
7. Transition is measured $\pm 200\text{mV}$ from steady state.
This parameter is sampled and not 100% tested.
8. /CS in high for the standby, low for active
/UB and /LB in high for the standby, low for active

DATA RETENTION ELECTRIC CHARACTERISTIC

TA=0°C to 70°C / -40°C to 85°C (I)

Symbol	Parameter	Test Condition	Min	Typ	Max	Unit	
VDR	Vcc for Data Retention	/CS ≥ Vcc - 0.2V or /UB = /LB ≥ Vcc-0.2V, VIN ≥ Vcc - 0.2V or VIN ≤ Vss + 0.2V	1.2	-	2.3	V	
ICCDR	Data Retention Current	Vcc=1.5V, /CS ≥ Vcc - 0.2V or /UB = /LB ≥ Vcc-0.2V, VIN ≥ Vcc - 0.2V or VIN ≤ Vss + 0.2V	LL	-	0.5	2	uA
			SL	-	-	1	uA
tCDR	Chip Deselect to Data Retention Time	See Data Retention Timing Diagram	0	-	-	ns	
tR	Operating Recovery Time		tRC(2)	-	-	ns	

Notes:

1. Typical values are under the condition of TA = 25°C.
2. tRC is read cycle time.

DATA RETENTION TIMING DIAGRAM

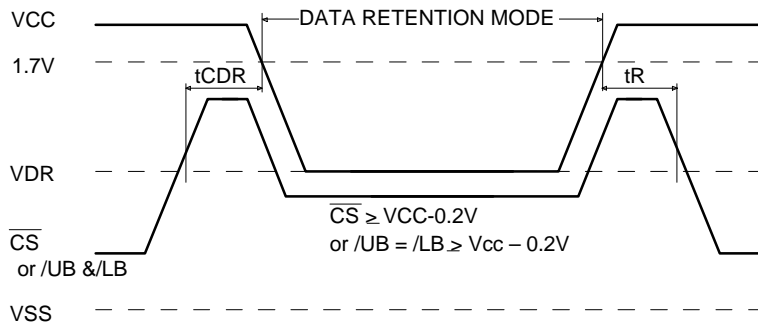

PACKAGE INFORMATION

48ball Fine-Pitch Ball Grid Array Package(F)

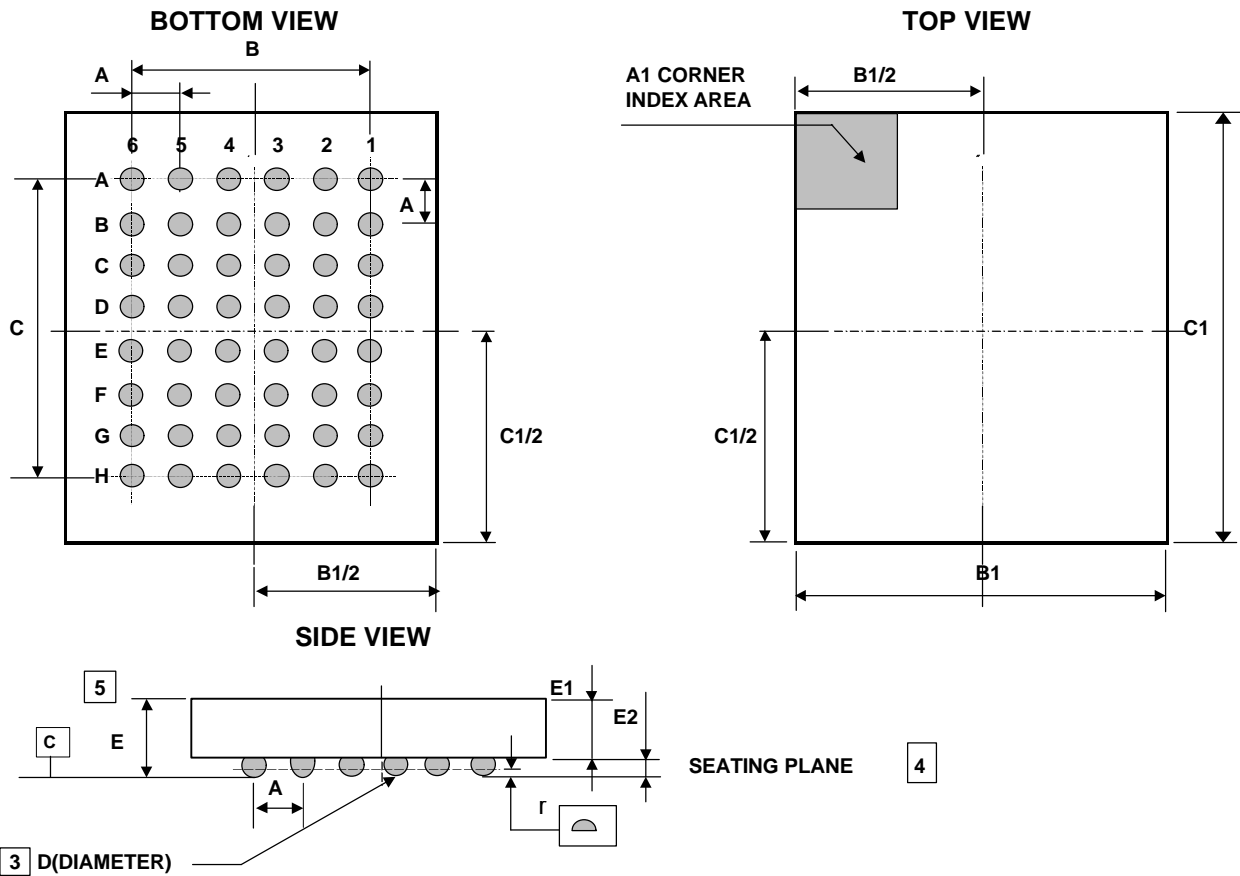

Note

1. DIMENSIONING AND TOLERANCING PER ASME Y14. SM-1994.
2. ALL DIMENSIONS ARE MILLIMETERS.
3. DIMENSION "D" IS MEASURED AT THE MAXIMUM SOLDER BALL DIAMETER IN A PLANE PARALLEL TO DATUM C.
4. PRIMARY DATUM C(SEATING PLANE) IS DEFINED BY THE CROWN OF THE SOLDER BALLS.
5. THIS IS A CONTROLLING DIMENSION.

Symbol	Min.	Typ.	Max.
A	-	0.75	-
B	-	3.75	-
B1	6.1	6.2	6.3
C	-	5.25	-
C1	6.2	6.3	6.4
D	0.3	0.35	0.4
E	0.9	1.0	1.1
E1	0.7	0.75	0.8
E2	0.2	0.25	0.3
r	-	-	0.1

MARKING INSTRUCTION

Package	Marking Example
FBGA	

Index

<ul style="list-style-type: none"> • HYSF611Cc : Part Name c : Power Consumption <ul style="list-style-type: none"> - L : Low Low Power - S : Super Low Power • ss : Speed <ul style="list-style-type: none"> - 85 : 85ns - 10 : 100ns - 12 : 120ns • t : Temperature <ul style="list-style-type: none"> - C : Industrial (-0 ~ 70 °C) - I : Industrial (-40 ~ 85 °C) • yy : Year (ex : 00 = year 2000, 01= year 2001) • ww : Work Week (ex : 12 = work week 12) • p : Process Code • xxxxx : Lot No. • KOR : Origin Country
<p>Note</p> <ul style="list-style-type: none"> - Capital Letter : Fixed Item - Small Letter : Non-fixed Item