

### FEATURES

- ADM8846 drives 6 LEDs from a 2.6 V to 5.5 V (li-ion) input supply**
- 1x/1.5x/2x Fractional Charge Pump to maximise power efficiency**
- 1% Max LED Current Matching**
- Up to 88% Power Efficiency over Li-ion Range**
- Powers Main and Sub Display LEDs with individual shutdown**
- Package footprint only 9mm<sup>2</sup> (3mm x 3mm)**
- Package height only 0.9mm**
- Low power shutdown mode**
- Shutdown Function**
- Soft-start limiting inrush current**

### APPLICATIONS

- Mobile phones with Main and Sub Displays**
- White LED Backlighting**
- Camera Flash/Strobes and Movie Light Applications**
- Micro TFT color displays**
- DSC**
- PDA's**

### GENERAL DESCRIPTION

The ADM8846 provides the power required to drive up to six LEDs, using charge pump technology. The LEDs are used for backlighting a color LCD display, with up to four LEDs in the main display and up to two LEDs in the sub display, with regulated constant current for uniform brightness intensity. Two digital input control pins, CTRL1 and CTRL2 control the shutdown operation and the brightness of the main and sub displays.

To maximize power efficiency, a charge pump that can operate in either of a 1x, 1.5x or 2x mode is used. The charge pump automatically switches between 1x/1.5x/2x modes based on the input voltage, to maintain sufficient drive for the LED anodes at the highest power efficiency.

Improved brightness matching of the LEDs is achieved by the use of a feedback pin to sense individual LED current with a maximum matching accuracy of 1%.

### FUNCTIONAL BLOCK DIAGRAM

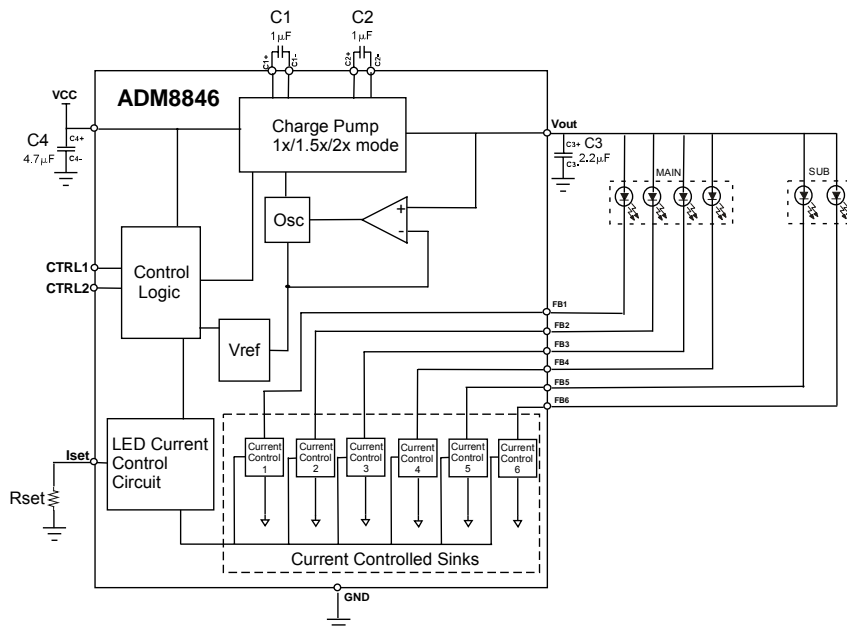

Figure 1. ADM8846 FUNCTIONAL BLOCK DIAGRAM

Rev. PrA\_06/04

Information furnished by Analog Devices is believed to be accurate and reliable. However, no responsibility is assumed by Analog Devices for its use, nor for any infringements of patents or other rights of third parties that may result from its use. Specifications subject to change without notice. No license is granted by implication or otherwise under any patent or patent rights of Analog Devices. Trademarks and registered trademarks are the property of their respective companies.

## TABLE OF CONTENTS

General Description .....	1	ADM8846 LED Brightness Control Using a PWM Signal Applied to $V_{PWM}$ .....	14
ADM8846—Specifications .....	3	ADM8846 LED Brightness Control Using a DC Voltage Applied to $V_{BRIGHT}$ .....	14
Thermal Characteristics .....	3	ADM8846 Applications .....	15
Absolute Maximum Ratings.....	4	Layout considerations and noise .....	15
ESD Caution.....	4	White LED Shorting .....	15
Pin Configuration and Function Description .....	5	Driving Fewer than six LEDs.....	15
Typical Performance Characteristics .....	6	Driving Flash LEDs.....	15
ADM8846 Operation .....	10	Driving Camera Light, Main and sub leds .....	16
Output Current Capability .....	11	ADM8846 Power Efficiency.....	17
Automatic Gain Control.....	11	Outline Dimensions .....	18
Current Matching .....	11	Ordering Guide .....	18
ADM8846 Brightness Control With a Digital PWM Signal.....	12		

## REVISION HISTORY

REV. PrA 06/04

## ADM8846—SPECIFICATIONS

( $V_{CC} = +2.6V$  TO  $5.5V$ ;  $T_A = -40^{\circ}C$  to  $85^{\circ}C$  unless otherwise noted;  $C1, C2 = 1.0\mu F$ ;  $C3 = 2.2\mu F$ ;  $C4 = 4.7\mu F$ )

Table 1.

PARAMETER	Min	Typ	Max	Units	Test Conditions
Input Voltage, $V_{CC}$	2.6		5.5	V	
Supply Current, $I_{CC}$		2.6	4	m A	All 6 LEDs Disabled, $V_{CC} = 3.3V$ , $R_{SET} = 7.08k\Omega$ $CTRL1 = 1$ , $CRTL2 = 1$
Shutdown Current			5	$\mu A$	$T_A = 25^{\circ}C$
Charge-Pump Frequency		1.5		M H z	
Charge Pump Mode Thresholds					
1.5x to 2x		3.33		V	
Accuracy			4	%	
2x to 1.5x		3.36		V	
Accuracy			4	%	
Hysteresis		40		m V	
1x to 1.5x		4.77		V	
Accuracy			4	%	
1.5x to 1x		4.81		V	
Accuracy			4	%	
Hysteresis		40		m V	
Iset Pin					
LED : LED Matching	-1		+1	%	$I_{LED} = 20mA$ , $V_{FB} = 0.4V$
LED : $I_{SET}$ Accuracy	-1		+1	%	$I_{LED} = 20mA$ , $R_{SET} = 7.08K$ , $V_{FB} = 0.4V$ , $V_{CC} = 3.6V$ , $T_A = 25^{\circ}C$ , Note 2
Iset pin voltage		1.18		V	
$I_{LED}$ to $I_{SET}$ Ratio		120			
Min Compliance on FB pin		0.2	0.3	V	$I_{SET} = 20mA$
Charge Pump Output Resistance		1.2	1.7	Ohm	1x Mode
		3.5	4.5	Ohm	1.5x Mode
		8.0	11	Ohm	2x Mode
LED Current			30	m A	See Note 1 and Figure 22
PWM	0.1		200	KHz	
Digital Inputs					
Input Hi	1.6			V	$2.6V \leq V_{CC} \leq 4.2V$
Input Low			0.4	V	$2.6V \leq V_{CC} \leq 4.2V$
Input Leakage Current			1	$\mu A$	
Charge Pump Power Efficiency		88		%	$CTRL1 = 1$ , $CRTL2 = 1$ , $V_{CC} = 3.4V$ , $V_{FB} = 0.2V$ , $I_{FB} = 20mA$
Vout Ripple		30		m V	$V_{CC} = 3.6V$ , $I_{LED} = 20mA$ , All 6 LEDs Enabled

### THERMAL CHARACTERISTICS

16-Lead LFCSP Package:

$\theta_{JA} = 50^{\circ}C/Watt$

# ABSOLUTE MAXIMUM RATINGS

Table 2. (TA = 25°C unless otherwise noted)

Parameter	Rating
Supply Voltage V <sub>CC</sub>	-0.3 V to +6.0 V
I <sub>SET</sub>	-0.3 V to +2.0 V
CTRL1, CTRL2	-0.3 V to +6.0 V
V <sub>OUT</sub> shorted (Note 3)	Indefinite
Feedback pins FB1 to FB6	-0.3 V to +6.0 V
Operating Temperature Range	-40°C to +85°C
V <sub>OUT</sub> (Note 4)	180mA
Storage Temperature Range	-65°C to +125°C
Power Dissipation	2mW
ESD Class	1

Stresses above those listed under Absolute Maximum Ratings may cause permanent damage to the device. This is a stress rating only; functional operation of the device at these or any other conditions above those indicated in the operational section of this specification is not implied. Exposure to absolute maximum rating conditions for extended periods may affect device reliability.

Note 1: LED Current should be derated above T<sub>A</sub> > 65C, refer to Figure 22.

Note 2: Guaranteed by design. Not 100% production tested.

Note 3: Short through LED.

Note 4: Based on long term current density limitations.

## ESD CAUTION

ESD (electrostatic discharge) sensitive device. Electrostatic charges as high as 4000 V readily accumulate on the human body and test equipment and can discharge without detection. Although this product features proprietary ESD protection circuitry, permanent damage may occur on devices subjected to high energy electrostatic discharges. Therefore, proper ESD precautions are recommended to avoid performance degradation or loss of functionality.

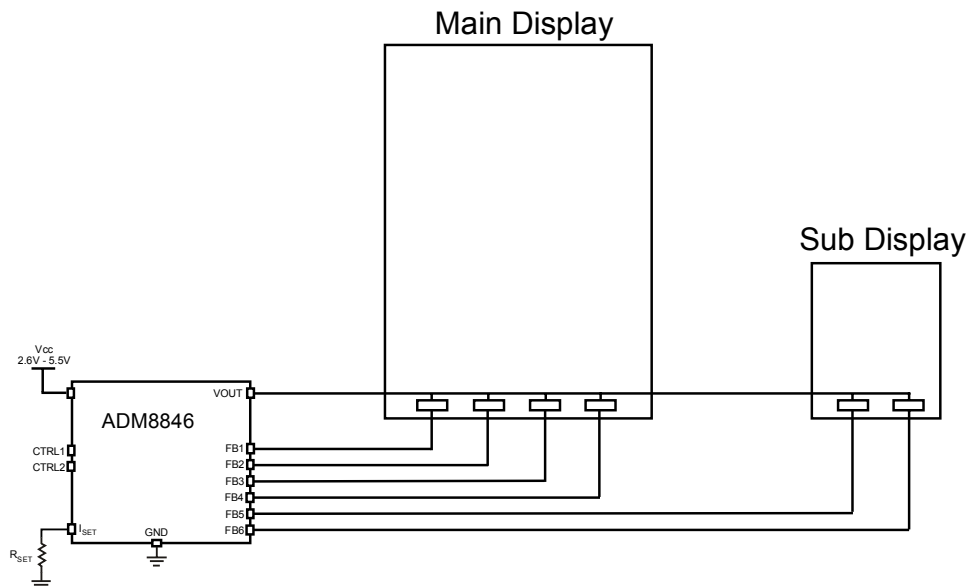

Figure 2. ADM8846 Typical Application Diagram

## PIN CONFIGURATION AND FUNCTION DESCRIPTION

Table 3.

Pin	ADM8846	Mnemonic	Function
1	VOUT		Charge Pump Output. A 2.2μF capacitor to ground is required on this pin. Connect Vout to the anodes of all the LEDs.
2	C2+		Flying Capacitor 2 Positive Connection
3	ISET		Bias current set input. The current flowing through the R <sub>SET</sub> resistor I <sub>SET</sub> is gained up by 120 to give the I <sub>LED</sub> current. Connect a resistor R <sub>SET</sub> to GND to set the bias current as V <sub>SET</sub> /R <sub>SET</sub> . (Note: V <sub>set</sub> = 1.18V)
4	FB1		LED1 Cathode connection and Charge Pump Feedback. The current flowing in LED1 is 120 times the current flowing through R <sub>SET</sub> , I <sub>SET</sub> .
5	FB2		LED2 Cathode connection and Charge Pump Feedback. The current flowing in LED2 is 120 times the current flowing through R <sub>SET</sub> , I <sub>SET</sub> . When using fewer than six LEDs this pin can be left unconnected.
6	FB3		LED3 Cathode connection and Charge Pump Feedback. The current flowing in LED3 is 120 times the current flowing through R <sub>SET</sub> , I <sub>SET</sub> . When using fewer than six LEDs this pin can be left unconnected.
7	FB4		LED4 Cathode connection and Charge Pump Feedback. The current flowing in LED4 is 120 times the current flowing through R <sub>SET</sub> , I <sub>SET</sub> . When using fewer than six LEDs this pin can be left unconnected.
8	FB5		LED5 Cathode connection and Charge Pump Feedback. The current flowing in LED5 is 120 times the current flowing through R <sub>SET</sub> , I <sub>SET</sub> . When using fewer than six LEDs this pin can be left unconnected.
9	FB6		LED6 Cathode connection and Charge Pump Feedback. The current flowing in LED6 is 120 times the current flowing through R <sub>SET</sub> , I <sub>SET</sub> . When using fewer than six LEDs this pin can be left unconnected.
10	GND		Device Ground Pin.
11	C2-		Flying Capacitor 2 Negative Connection.
12	CTRL2		Digital Input. 3 V CMOS Logic. Used with CTRL1 to control the shutdown operation of the main and sub LEDs.
13	CTRL1		Digital Input. 3 V CMOS Logic. Used with CTRL2 to control the shutdown operation of the main and sub LEDs.
14	C1-		Flying Capacitor 1 Negative Connection.
15	Vcc		Positive Supply Voltage Input. Connect this pin to a 2.6 V to 5.5 V supply with a 4.7μF decoupling capacitor.
16	C1+		Flying Capacitor 1 Positive Connection.
-	EP		Expose Paddle. Connect the exposed paddle to GND.

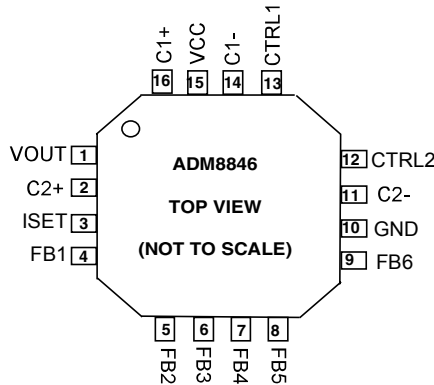

Figure 3. ADM8846 Pin Configuration

ESD (electrostatic discharge) sensitive device. Electrostatic charges as high as 4000 V readily accumulate on the human body and test equipment and can discharge without detection. Although this product features proprietary ESD protection circuitry, permanent damage may occur on devices subjected to high energy electrostatic discharges. Therefore, proper ESD precautions are recommended to avoid performance degradation or loss of functionality.



TYPICAL PERFORMANCE CHARACTERISTICS

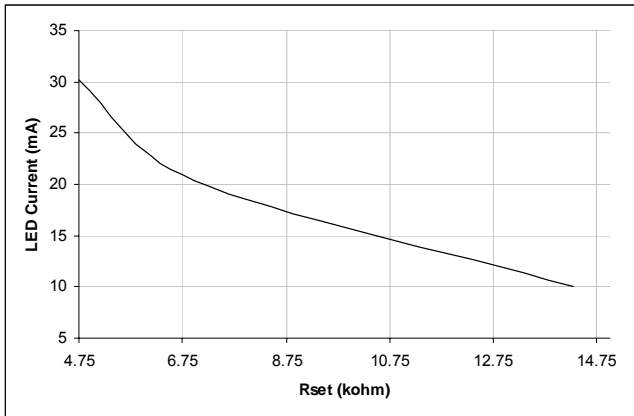

Figure 4. LED Current vs.  $R_{SET}$  Resistor

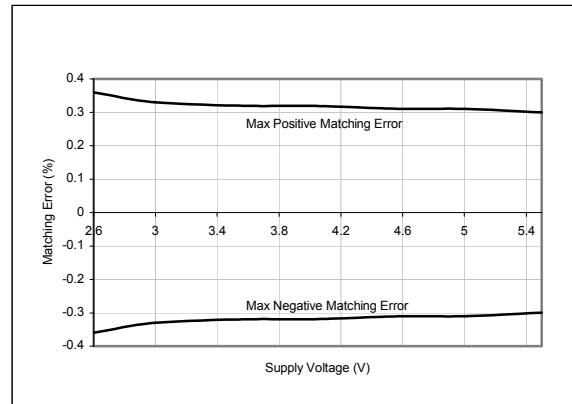

Figure 5. LED Current Matching Error (%) vs. Supply Voltage (V),  
 $T_A = 25^\circ\text{C}$  and  $I_{LED} = 20\text{mA}$

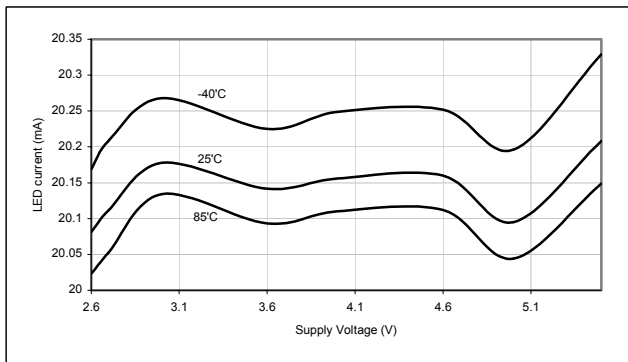

Figure 6. LED Current (mA) vs. Temperature ( $^\circ\text{C}$ ), 6 LEDs enabled.

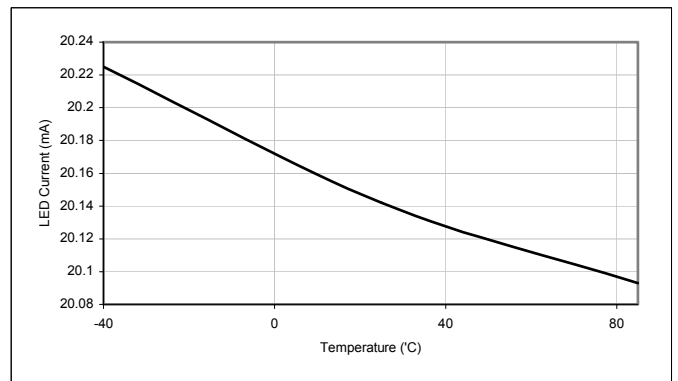

Figure 7.  $I_{LED}$  (mA) Variation over Temperature ( $^\circ\text{C}$ ), with  $V_{CC} = 3.6\text{V}$

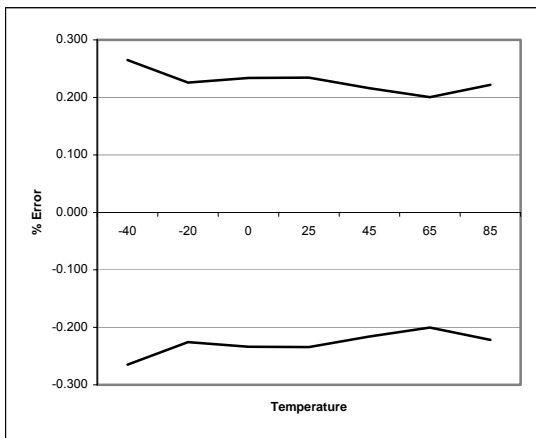

Figure 8.  $I_{LED}$  Matching (%) over Temperature ( $^\circ\text{C}$ ), with  $V_{CC} = 3.6$ ,  
 $I_{LED} = 20\text{mA}$ , 6 LEDs enabled.

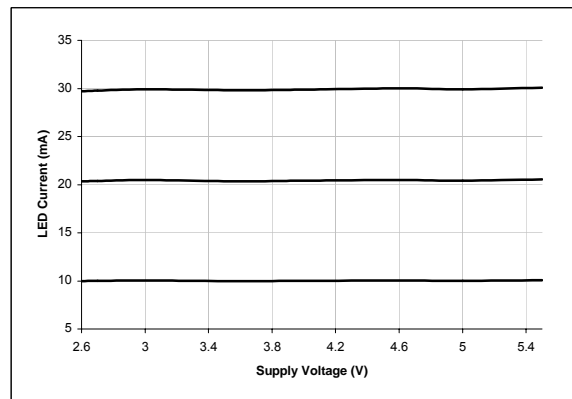

Figure 9. LED Current (mA) vs. Supply Voltage (V)

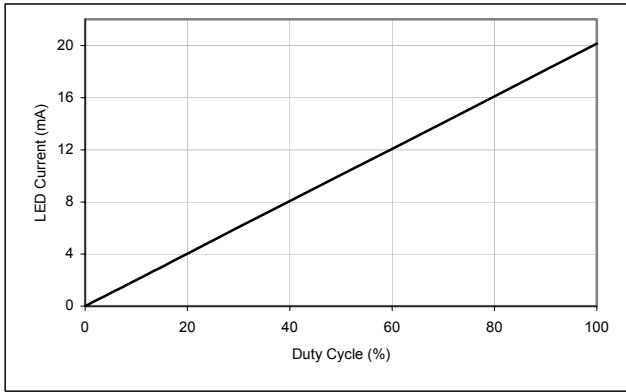

Figure 10. LED Current (mA) vs. PWM Dimming (varying Duty Cycle), 6 LEDs enabled, Freq = 1kHz.

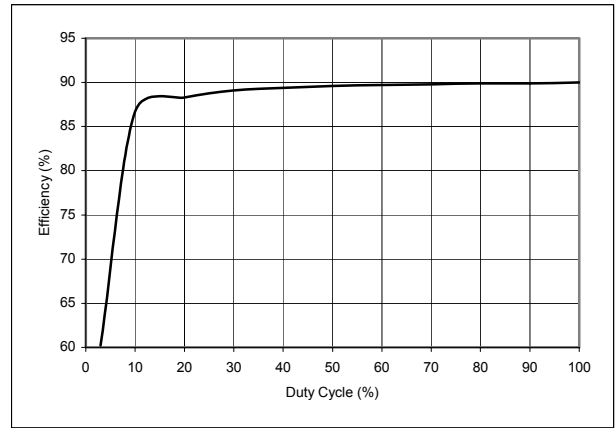

Figure 11. LED Efficiency vs. Varying Duty Cycle of 1kHz PWM signal, with 6 LEDs enabled, 20mA/LED.

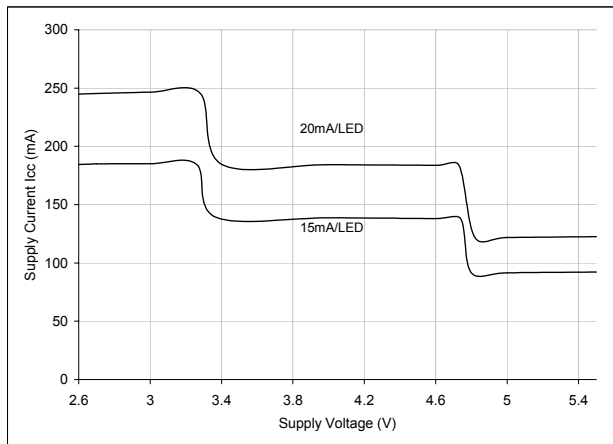

Figure 12. Input Current vs. Supply Voltage, with 6 LEDs enabled

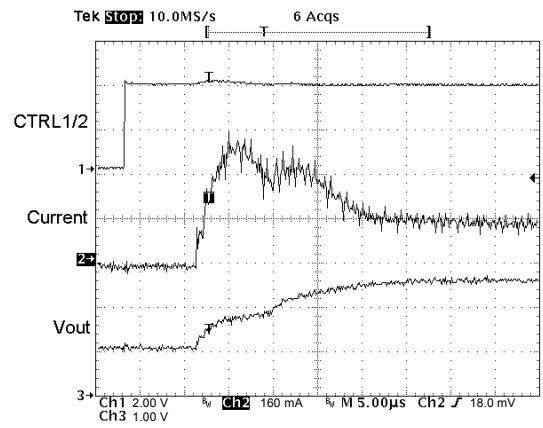

Figure 13. Softstart showing the initial in-rush current and Vout variation with 6 LEDs @ 20mA/LED, V<sub>CC</sub> = 3.6V



Figure 14. 1.5x Mode Operating Waveforms

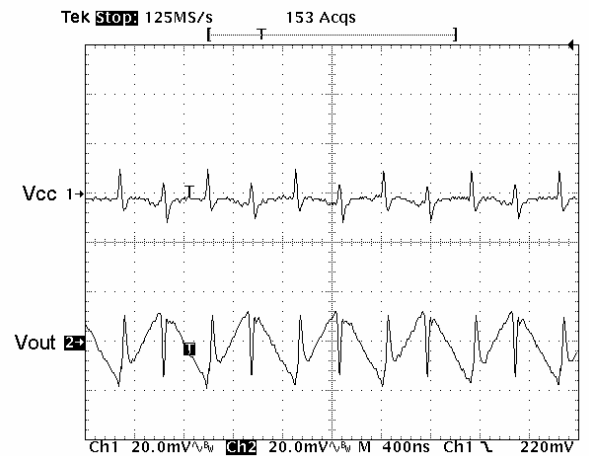

Figure 15. 2x Mode Operating Waveforms

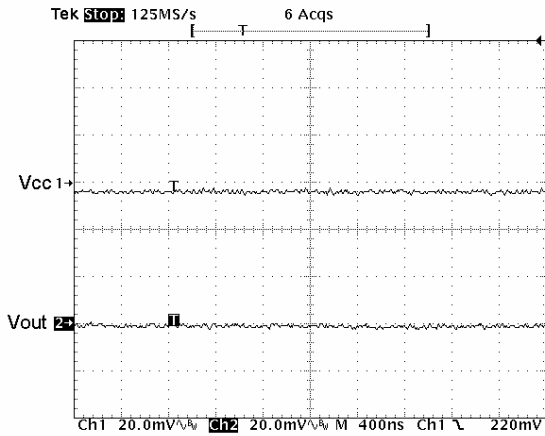

Figure 16. 1x Mode Operating Waveforms

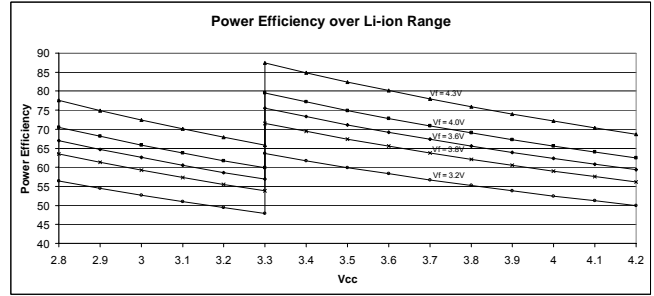

Figure 17. Power Efficiency vs. Supply Voltage over Li-ion Range (6 LEDs @ 20mA/LED)

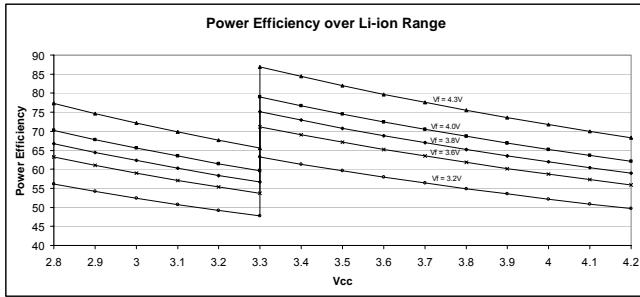

Figure 18. Power Efficiency vs. Supply Voltage over Li-ion Range (6 LEDs @ 15mA/LED)

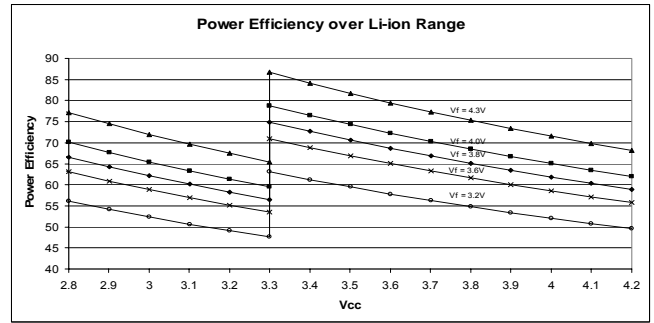

Figure 19. Power Efficiency vs. Supply Voltage over Li-ion Range (4 LEDs @ 20mA/LED)

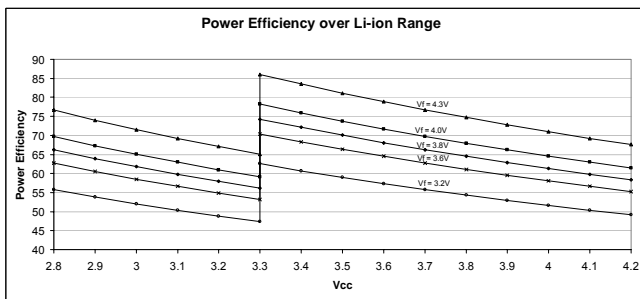

Figure 20. Power Efficiency vs. Supply Voltage over Li-ion Range (4 LEDs @ 15mA/LED)

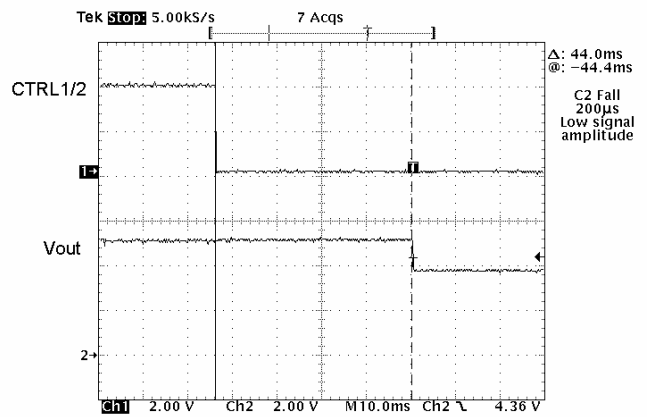

Figure 21. TPC Delay



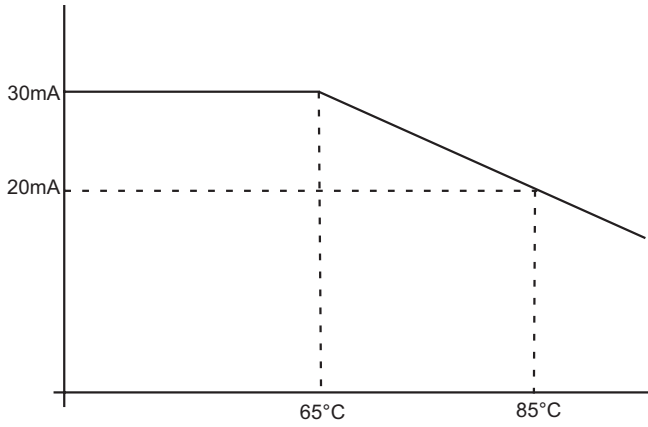

Figure 22. Max LED Current vs. Ambient Temperature (6 LEDs Connected)

## ADM8846 OPERATION

The ADM8846 charge pump driver for LCD white LED backlights implements a multiple gain charge pump (1x, 1.5x, 2x) to maintain the correct voltage on the anodes of the LEDs over a 2.6V to 5.5V (li-ion) input supply voltage. The charge pump automatically switches between 1x/1.5x/2x modes based on the input voltage, to maintain sufficient drive for the LED anodes, with  $V_{CC}$  input voltages as low as 2.6V. It also includes regulation of the charge pump output voltage for supply voltages up to 5.5V. The ADM8846 six LEDs are arranged into two groups; main and sub. The main display can be up to four LEDs (FB1 to FB4) and the sub display can be up to two LEDs (FB5 and FB6), see Figure 23. Two digital input control pins, CTRL1 and CTRL2, control the shutdown operation and the brightness of the main and sub displays, see Table 4.

CTRL1	CTRL2	LED Shutdown Operation
0	0	Sub Display Off / Main Display Off
0	1	Sub Display Off / Main Display On
1	0	Sub Display On / Main Display Off
1	1	Sub Display On / Main Display On

Table 4. ADM8846 Digital Inputs Truth Table

An external resistor  $R_{SET}$  is connected between the  $I_{SET}$  pin and GND, this resistor sets up a reference current  $I_{SET}$  which is gained up by 120 internally within the ADM8846 to produce the  $I_{LED}$  currents of up to 30mA/LED, ( $I_{LED} = I_{SET} * 120$  and  $I_{SET} = 1.18V / R_{SET}$ ). The ADM8846 uses six individual current sinks to individually sense each LED current with a maximum matching performance of 1%. This current matching performance ensures uniform brightness across a color display.

The ADM8846 provides the option to control the brightness of the white LEDs with a digital PWM signal applied to CTRL1 and/or CTRL2. The duty cycle of the applied PWM signal determines the brightness of the main and/or sub display backlight white LEDs. The ADM8846 also allows the brightness of the white LEDs to be controlled using a DC voltage, refer to page 14, Figure 27Figure . Soft-start circuitry limits the inrush current flow at power up. The ADM8846 is fabricated using CMOS technology for minimal power consumption and is packaged in a 16-Lead Frame Chip Scale Package.

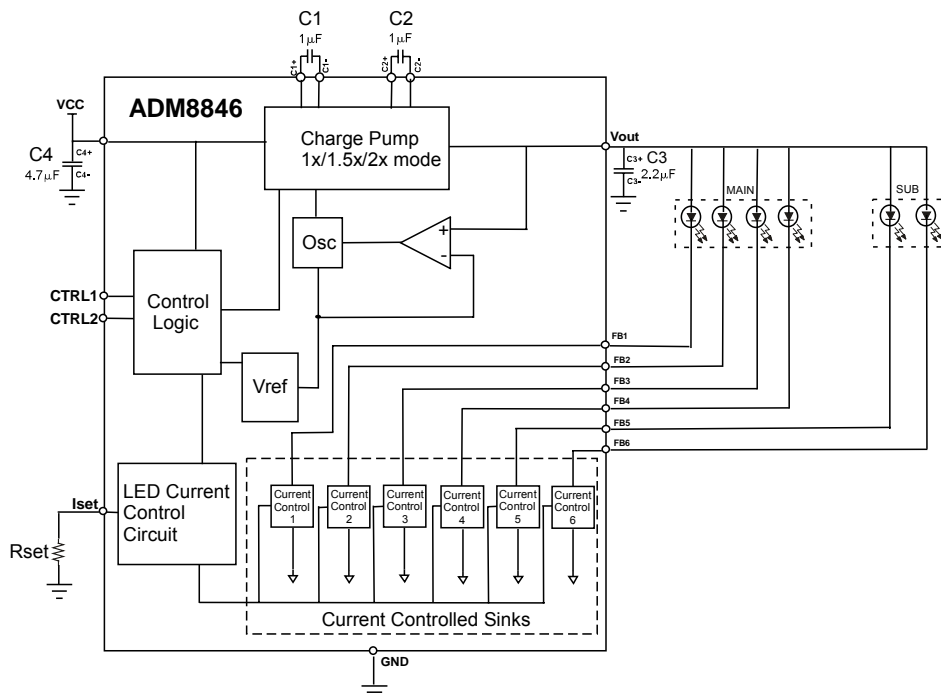

Figure 23. ADM8846 FUNCTIONAL BLOCK DIAGRAM

**OUTPUT CURRENT CAPABILITY**

The ADM8846 is capable of driving up to 30mA of current to each of the six LEDs given an input voltage of 2.6V to 5.5V. The LED currents have a max current matching of 1% between any two LED currents. An external resistor R<sub>SET</sub> sets the output current, approximated by the following equation:

$$R_{SET} = 120 \times (1.18V / I_{LED}).$$

In order for the LED currents to be regulated properly, sufficient headroom voltage (compliance) must be present. The compliance refers to the minimum amount of voltage that must be present across the internal current sinks in order to ensure the desired current and matching performance is realizable. To ensure the desired current is obtained, apply the following equations to find the minimum input voltage required:

$$V_{OUT} - V_F \geq \text{Compliance}$$

V<sub>F</sub> is the LED forward voltage. For 20mA/LED the compliance is 0.2V typ and 0.3V max, see Table 5.

I <sub>LED</sub>	R <sub>SET</sub>	Typ. Compliance
15mA	9.44k Ohms	0.17V
20mA	7.08k Ohms	0.20V
30mA	4.72k Ohms	0.34V

Table 5. I<sub>LED</sub>, R<sub>SET</sub> and Compliance Table

When the ADM8846 charge pump is loaded with 180mA (six LEDs at 30mA/LED) the ambient operating temperature is reduced, see Figure 22.

**AUTOMATIC GAIN CONTROL**

The Automatic Gain Control block controls the operation of the charge pump by selecting the appropriate gain for the charge pump, to maintain sufficient drive for the LED anodes at the highest power efficiency over a 2.6V to 5.5V input supply range. The charge pump switching thresholds are:

Gain	Threshold
1.5x to 2x	3.33V
2x to 1.5x	3.36V
1x to 1.5x	4.77V
1.5x to 1x	4.81V

Table 6. Charge Pump Switching Thresholds

**CURRENT MATCHING**

The 1% max current matching performance is defined by the following two equations:

$$I_{AVG} = (I_{MAX} + I_{MIN})/2$$

$$\text{Max Matching Error} = [(I_{MAX} - I_{AVG})/I_{AVG}] * 100$$

or

$$\text{Min Matching Error} = [(I_{MIN} - I_{AVG})/I_{AVG}] * 100$$

Where I<sub>MAX</sub> is the largest I<sub>LED</sub> current and I<sub>MIN</sub> is the smallest I<sub>LED</sub> current.

## ADM8846 BRIGHTNESS CONTROL WITH A DIGITAL PWM SIGNAL

PWM brightness control provides the widest brightness control method by pulsing the white LEDs on and off using the digital input control pins, CTRL1 and/or CTRL2. PWM brightness control also removes any chromaticity shifts associated with changing the white LED current, as the LEDs operate at either zero current or full current (set by the  $R_{SET}$  resistor).

The digital PWM signal applied with a frequency of 100Hz to 200kHz turns the current control sinks on and off using CTRL1 and/or CTRL2. The average current through the LEDs changes with the PWM signal duty cycle. If the PWM frequency is much less than 100Hz, flicker may be seen in the LEDs. For the ADM8846, zero duty cycle will turn off the LEDs and a 50% duty cycle will result in an average LED current  $I_{LED}$  being half the programmed LED current. For example, if  $R_{SET}$  is set to program 20mA/LED, a 50% duty cycle will result in an average  $I_{LED}$  of 10mA/LED.  $I_{LED}$  being half the programmed LED current.

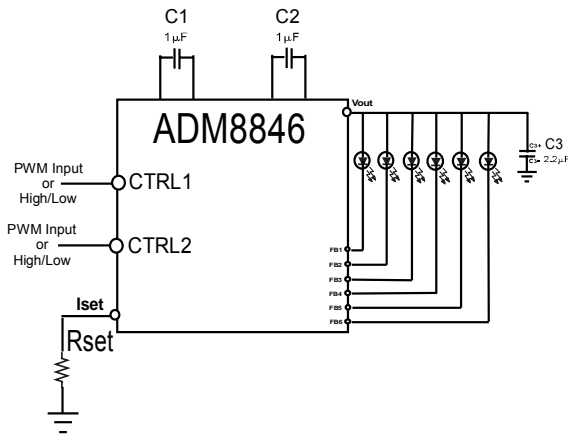

Figure 24. ADM8846 Digital PWM Brightness Control Application Diagram

By applying a digital PWM signal to the digital input control pins, CTRL1 and/or CTRL2 you can adjust the brightness of the sub and/or main displays. The ADM8846 six white LEDs are organized into 2 groups, Main Display (FB1-FB4) and Sub Display (FB4 - FB6), refer to Page 10.

The ADM8846 main and sub display brightness can be controlled together or separately. By applying a digital PWM signal to both CTRL1 and CTRL2 pins. The duty cycle of the applied digital PWM signal determines the brightness of the main and sub displays together. By varying the duty cycle of the applied PWM signal you vary the brightness of the main and sub displays from 0% to 100%.

By holding CTRL1 low and applying a digital PWM signal to CTRL2, the sub display is turned off and the main display is on, the brightness of the main display is determined by the duty cycle off the applied digital PWM signal.

Also applying a digital PWM signal to CTRL1 and holding CTRL2 low, the sub display is turned on and the main display is off, the brightness of the sub display is determined by the duty cycle off the applied digital PWM signal.

Also applying a digital PWM signal to CTRL1 and holding CTRL2 high, the sub display is turned on and the main display is turned on, the brightness of the sub display is determined by the duty cycle off the applied digital PWM signal. The brightness of the main display is set to the maximum (maximum is set by the  $R_{SET}$  resistor).

By holding CTRL1 high and applying a digital PWM signal to CTRL2, the sub display is turned on and the main display is on, the brightness of the main display is determined by the duty cycle off the applied digital PWM signal. The brightness of the sub display is set to the maximum (maximum is set by the  $R_{SET}$  resistor)

When CTRL1 and CTRL2 go low the LED Current Control Sinks shutdown. Shutdown of the Charge Pump is delayed by 15mS. This timeout period ( $t_{CP}$ ) allows the ADM8846 to determine if a digital PWM signal is present on CTRL1 and CTRL2 or if the user has selected a full chip shutdown, see Figure 25 ADM8846 Application Timing.

If digital PWM brightness control of the LEDs is not required then a constant logic level 1 ( $V_{CC}$ ) or 0 (GND) must be applied.

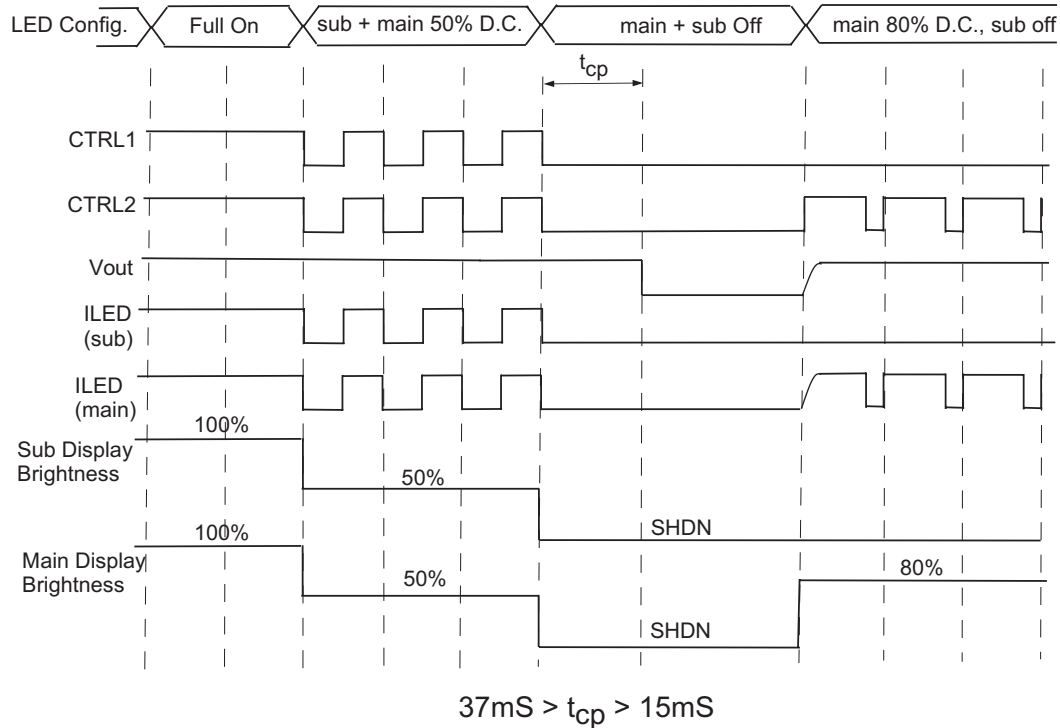

Figure 25. ADM8846 Application Timing

CTRL1	CTRL2	LED Operation	Notes
0	0	Sub Display Off / Main Display Off (Full Shutdown)	5a, 5d
0	1	Sub Display Off / Main Display On	5a, 5c
1	0	Sub Display On / Main Display Off	5a, 5d
1	1	Sub Display On / Main Display On (Full On)	5a, 5c
0	PWM	Sub Display Off/ Digital PWM Brightness Control on Main Display	5b, 5e
PWM	0	Digital PWM Brightness Control on Sub Display / Main Display Off	5e, 5d
1	PWM	Sub Display On/ Digital PWM Brightness Control on Main Display	5e a,5
PWM	1	Digital PWM Brightness Control on Sub Display / Main Display On	5e, 5e
PWM	PWM	Digital PWM Brightness Control on Sub and Main Display	5e, 5e

Table 7. ADM8846 Digital Inputs Truth Table

The six white LED in the ADM8846 are arranged into 2 groups, sub and main. It is possible to configure the six LEDs as in Table 7, ADM8846 Digital Inputs Truth Table, refer also to Figure 25, ADM8846 Application Timing.

Note 5a: Sub Display on means the display is on with the maximum brightness set by the R<sub>SET</sub> resistor. CTRL1 = 1 means a constant logic level (V<sub>CC</sub>) is applied to CTRL1.

Note 5b: Sub Display off means the sub display LEDs only is off. CTRL1 = 0 means a constant logic level (GND) is applied to CTRL1.

Note 5c: Main Display on means the display is on with the maximum brightness set by the R<sub>SET</sub> resistor. CTRL2 = 1 means a constant logic level (V<sub>CC</sub>) is applied to CTRL2.

Note 5d: Main Display off means the main display only is off. CTRL2 = 0 means a constant logic level (GND) is applied to CTRL2.

Note 5e: PWM means a digital PWM signal is applied to the CTRL1 and/or CTRL2 pin with a frequency from 100Hz to 200kHz.

**ADM8846 LED BRIGHTNESS CONTROL USING A PWM SIGNAL APPLIED TO V<sub>PWM</sub>**

Adding two external resistors and a capacitor as shown on Figure 26, can also be used to achieve PWM brightness control. This PWM brightness control method can be used instead of CTRL1 and/or CTRL2 digital PWM brightness control. With this configuration, CTRL1 and CTRL2 digital logic pins can be used to control shutdown of the white LEDs, while V<sub>PWM</sub> can be used to control the brightness of all the white LEDs. By applying a high-frequency PWM signal (Amplitude 0V to 2.5V) to drive an R-C-R filter on the I<sub>SET</sub> pin of the ADM8846. A 0% PWM duty cycle corresponds to 20mA/LED, while a 100% PWM duty cycle corresponds to a 0mA/LED. At PWM frequencies above 5kHz, C5 may be reduced. Refer to Figure 26, ADM8846 PWM Brightness Control Using Filtered-PWM Signal. The amplitude of the PWM signal must be 0 V and 2.5 V only, in order to have 20mA flowing in each LED.

$$I_{LED} = \frac{I_{SET\_Voltage} * 120 * (1 - \frac{Duty\ Cycle}{100})}{\frac{R_{SET} * 2R}{R_{SET} + 2R}}$$

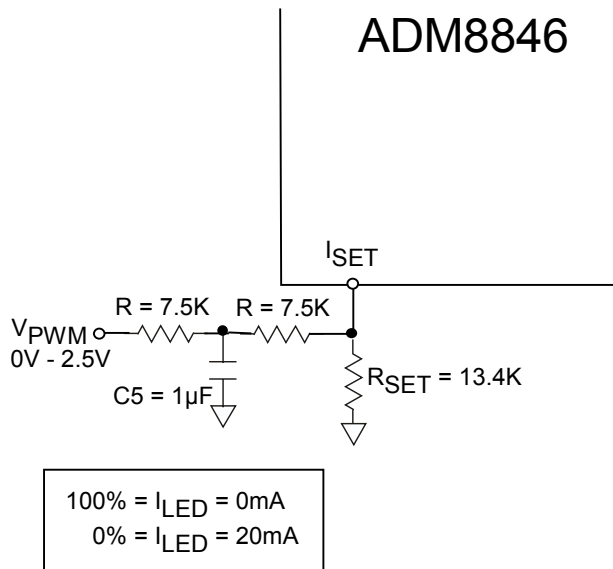

Figure 26. ADM8846 PWM Brightness Control Using Filtered-PWM Signal

**ADM8846 LED BRIGHTNESS CONTROL USING A DC VOLTAGE APPLIED TO V<sub>BRIGHT</sub>**

Adding one resistor as shown in figure 27, this configuration can also be used to achieve brightness control of the white LEDs using a DC voltage applied to the V<sub>BRIGHT</sub> node. Figure 28 shows an application example of LED Brightness control using a DC Voltage with a amplitude of 0V to 2.5V, applied to V<sub>BRIGHT</sub>.

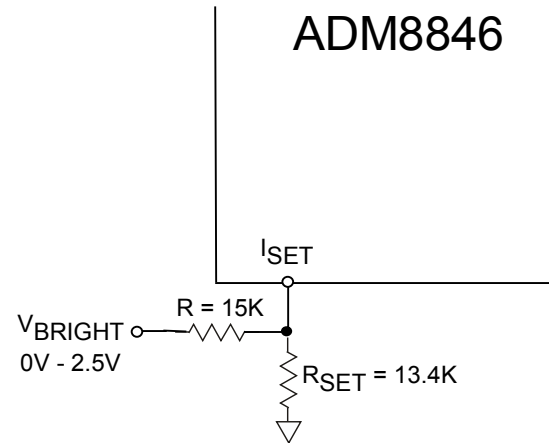

Figure 27. ADM8846 PWM Brightness Control Using a DC Voltage applied to V<sub>BRIGHT</sub>

The equation for I<sub>LED</sub> is:

$$I_{SET} = [(1/R_{SET} + 1/R)(V_{SET})] - [(1/R)(V_{BRIGHT})]$$

$$I_{LED} = 120 * I_{SET}$$

Where R = 15k Ohm, V<sub>SET</sub> = voltage at I<sub>SET</sub> pin (1.18V)

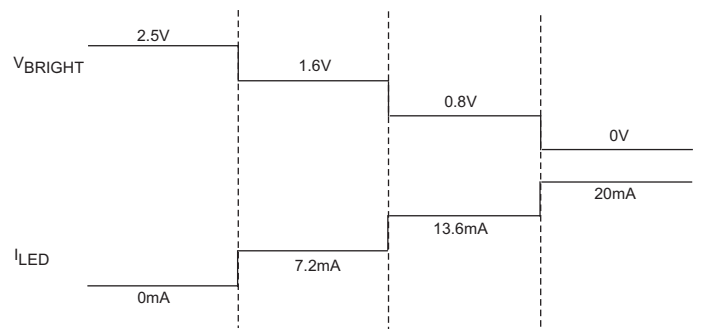

Figure 28. ADM8846 PWM Brightness Control Application Diagram Using a DC Voltage applied to V<sub>BRIGHT</sub>

## ADM8846 APPLICATIONS

### LAYOUT CONSIDERATIONS AND NOISE

Because of the ADM8846 switching behavior, PCB trace layout is an important consideration. To ensure optimum performance a ground plane should be used, all capacitors (C1,C2,C3,C4) should be located with minimal track lengths to the pins of the ADM8846.

### WHITE LED SHORTING

If a LED is shorted, the ADM8846 will continue to drive the remaining LEDs with  $I_{LED}$  per LED ( $I_{LED} = I_{SET} * 120$ ). This is because the ADM8846 uses six internal current sinks to produce the LED current. If a LED is shorted, then the ADM8846 will continue to sink ( $I_{SET} * 120$ )mA as programmed by the  $R_{SET}$  resistor through the shorted LED.

### DRIVING FEWER THAN SIX LEDs

The ADM8846 can be operated with less than 6 LEDs in parallel, simply leave the un-used FBx pins floating or connected to GND. For example Figure 29, shows five LEDs being powered by the ADM8846 or Figure 30 shows three main LEDs + one sub LED.

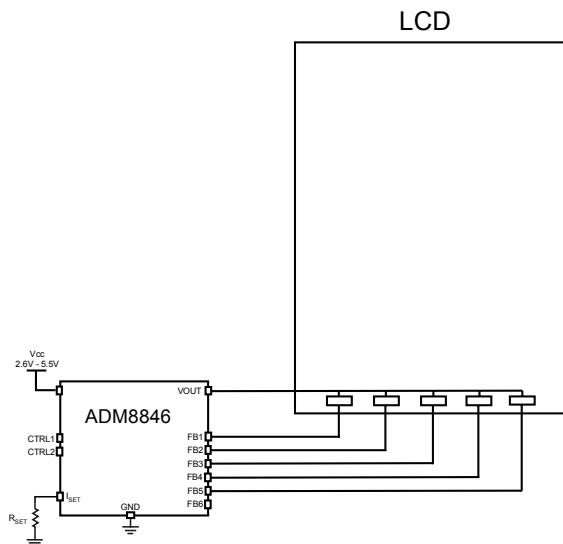

Figure 29. ADM8846 Driving Five White LEDs

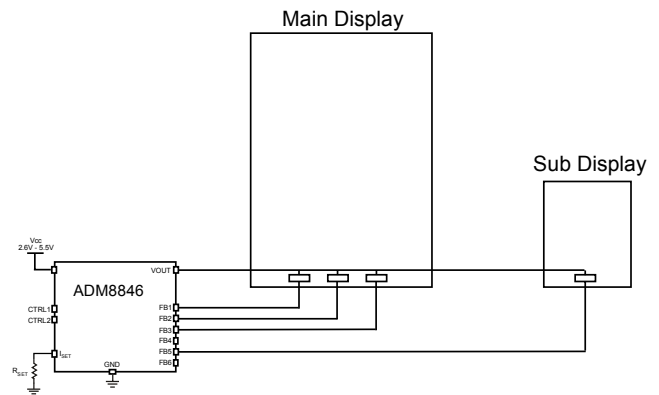

Figure 30. ADM8846 Driving 3three Main and one Sub

### DRIVING FLASH LEDs

The ADM8846 can be operated with any two FBx pins operated in parallel to double the combined LED current supplied by the ADM8846. For example if three Flash LEDs are required to be driven with 60mA/LED. Then the ADM8846 can be configured as follows, see Figure 31, see also Figure 22, Max LED Current vs. Ambient Temperature.

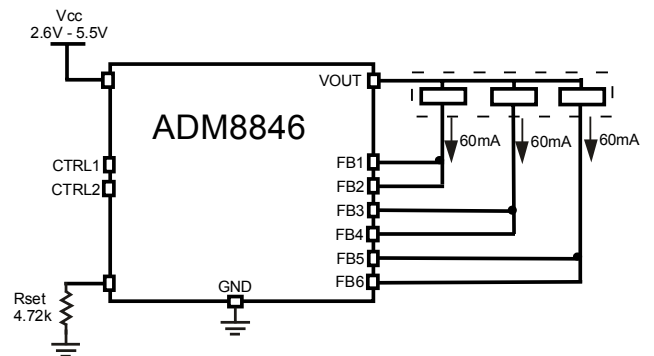

Figure 31. ADM8846 Driving three flash LEDs

**DRIVING CAMERA LIGHT, MAIN AND SUB LEDs**

The ADM8846 can also be configured to power a camera light which is composed of four white LEDs in parallel, packaged into one package. FB1 to FB4 now power the camera light and FB5 and FB6 powers the main display and the sub display LED is powered from the ADM8846 by using an external current mirror to control the current flowing through the sub white LED, see Figure 32. All white LEDs have 15mA/LED, therefore total load on the ADM8846 charge pump is 105mA, max load on the ADM8846 charge pump is 180mA see Figure 22.

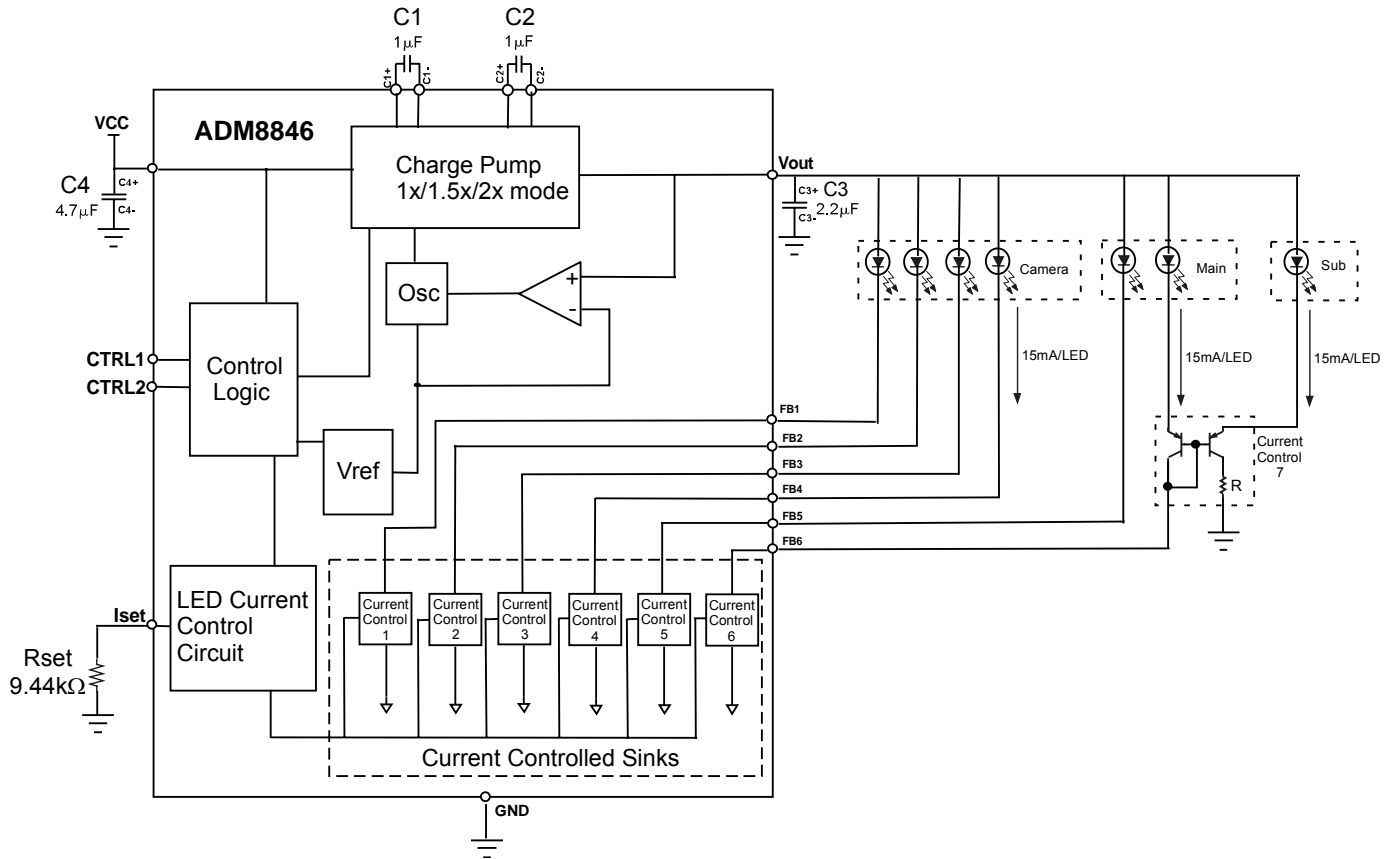

Figure 32. ADM8846 Driving Camera Light + Two Main + One Sub



## ADM8846 POWER EFFICIENCY

The ADM8846 power efficiency ( $\eta$ ) equations, are as follows:

$$\eta = P_{OUT}/P_{IN}$$

$$P_{IN} = ((V_{CC} * I_{LOAD} * Gain) + (I_Q * V_{CC}))$$

$$P_{OUT} = 6 * (V_F * I_{LED})$$

$I_Q$  : Quiescent current of the ADM8846, 2.6mA.

$V_F$  : LED Forward Voltage

Gain : Charge Pump Mode (1x, 1.5x, 2x)

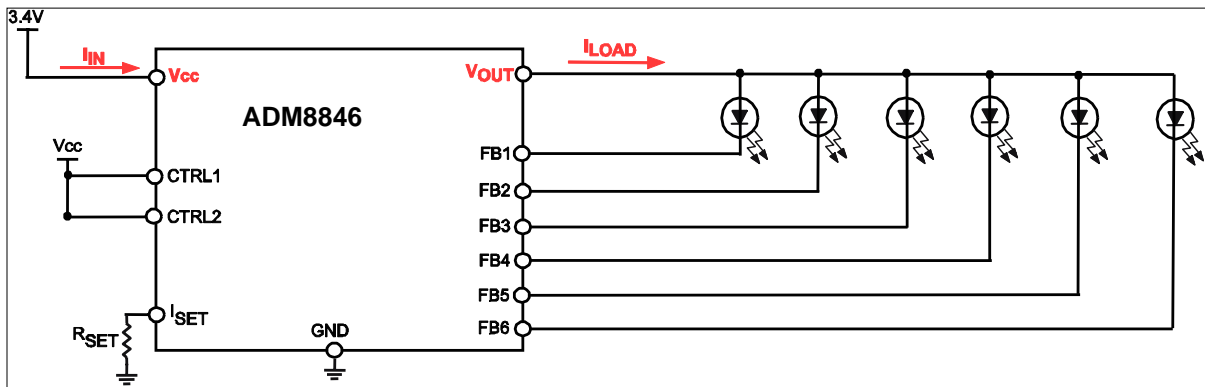

Figure 33. ADM8846 Charge Pump Power Efficiency Diagram, Example 1.

**Example 1:** The ADM8846 driving six white LED with 20mA/LED at  $V_{CC} = 3.4V$  (1.5x mode), LED  $V_F = 4.5V$ .

$$P_{IN} = ((V_{CC} * I_{LOAD} * Gain) + (V_{CC} * I_Q))$$

$$P_{IN} = ((3.4 * 120mA * 1.5) + (3.4 * 2.6mA))$$

$$P_{IN} = ((0.612) + (0.00884))$$

$$P_{IN} = 0.62084$$

$$P_{OUT} = 6(V_F * I_{LED})$$

$$P_{OUT} = 6(4.5V * 20mA)$$

$$P_{OUT} = 0.54$$

$$\eta = P_{OUT}/P_{IN}$$

$$\eta = 0.54/0.62084$$

$$\eta = 87 \%$$

**Example 2:** The ADM8846 driving six white LED with 20mA/LED at  $V_{CC} = 3.4$  (1.5x mode), LED  $V_F = 3.6V$ .

$$P_{IN} = ((V_{CC} * I_{LOAD} * Gain) + (V_{CC} * I_Q))$$

$$P_{IN} = ((3.4 * 120mA * 1.5) + (3.4 * 2.6mA))$$

$$P_{IN} = ((0.612) + (0.00884))$$

$$P_{IN} = 0.62084$$

$$P_{OUT} = 6(V_F * I_{LED})$$

$$P_{OUT} = 6(3.6V * 20mA)$$

$$P_{OUT} = 0.432$$

$$\eta = P_{OUT}/P_{IN}$$

$$\eta = 0.432/0.62084$$

$$\eta = 70 \%$$

# OUTLINE DIMENSIONS



16-Lead Lead Frame Chip Scale Package [LFCSP]  
 3 x 3 mm Body  
 (CP-16-4)

Dimensions shown in millimeters

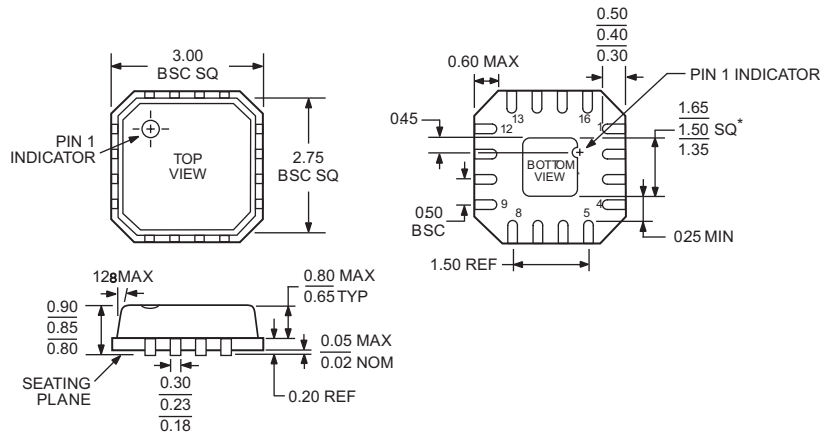

\*COMPLIANT TO JEDEC STANDARDS MO-220-VEED-2 EXCEPT FOR EXPOSED PAD DIMENSION

Figure 34. 16-Lead Frame Chip Scale package [LFCSP] (CP-16)—Dimensions shown in millimeters

## ORDERING GUIDE

Model	Temperature Range	Package Description	Package Option
ADM8846ACPZ	-40°C to + 85°C	16-Lead LFCSP	CP-16
ADM8846ACPZ-REEL7	-40°C to + 85°C	16-Lead LFCSP	CP-16

CP: Chip Scale Package

Z: Lead Free Part

This datasheet has been download from:

[www.datasheetcatalog.com](http://www.datasheetcatalog.com)

Datasheets for electronics components.