

# Am79514

## Subscriber Line Interface Circuit

### DISTINCTIVE CHARACTERISTICS

- Programmable constant-current feed
- Programmable loop-detect threshold
- On-chip switching regulator for low-power dissipation
- Polarity reversal feature
- Optimized for -60 V battery
- Line feed characteristics independent of battery variations
- Two-wire impedance set by single external impedance
- Tip Open state for ground-start lines
- Ring and test relay drivers
- On-hook transmission

### BLOCK DIAGRAM

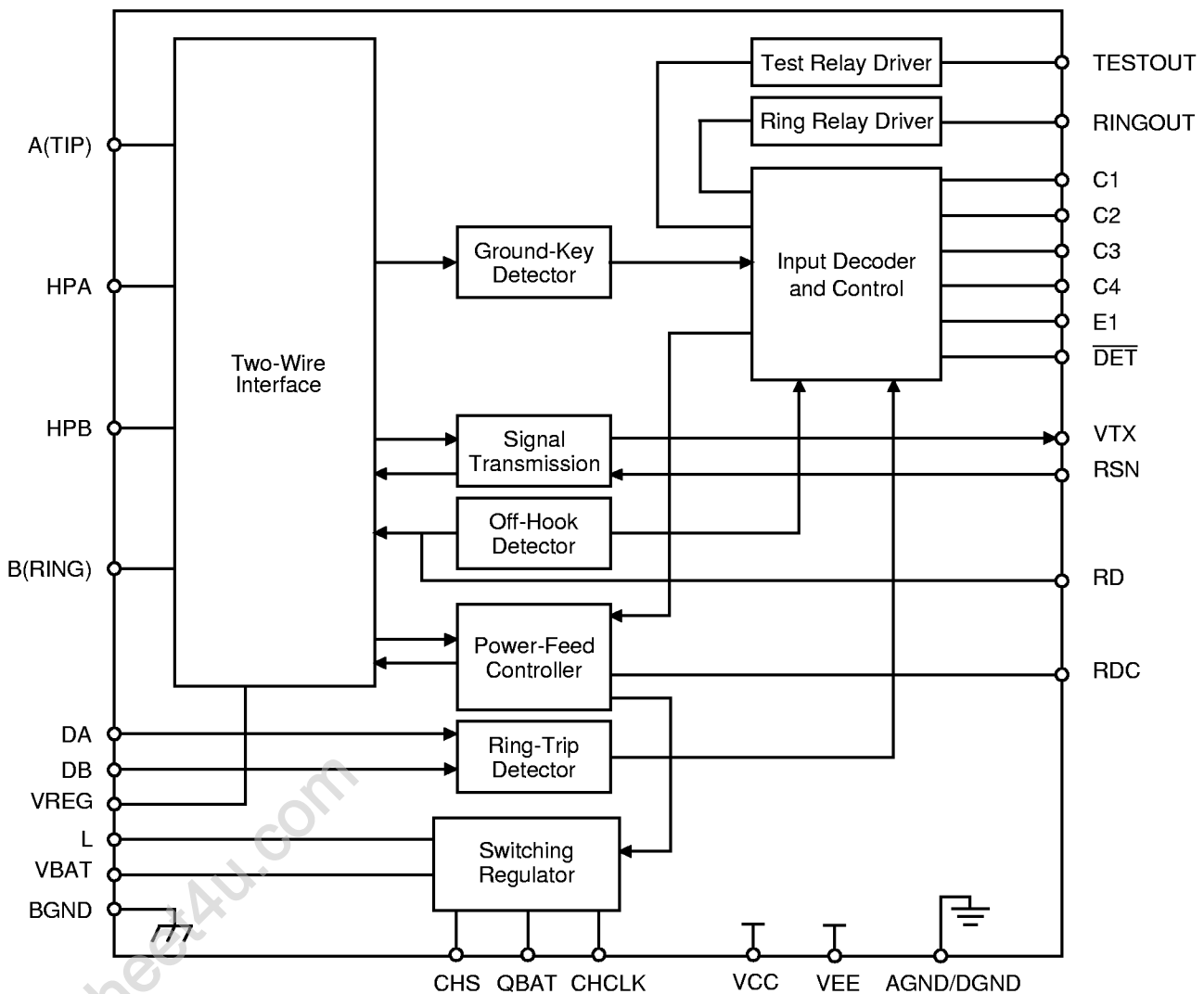

**ORDERING INFORMATION**

**Standard Products**

AMD standard products are available in several packages and operating ranges. The order number (Valid Combination) is formed by a combination of the elements below.

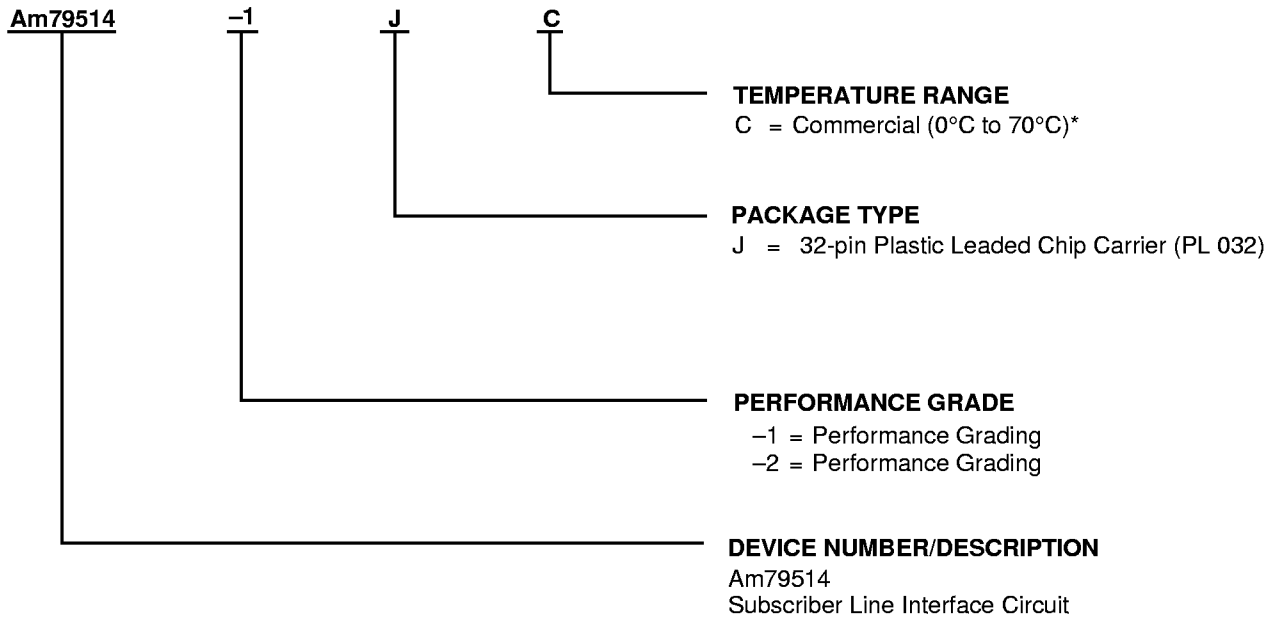

Valid Combinations		
Am7951X	-1	JC
	-2	

**Valid Combinations**

Valid Combinations list configurations planned to be supported in volume for this device. Consult the local AMD sales office to confirm availability of specific valid combinations, to check on newly released combinations, and to obtain additional data on AMD's standard military grade products.

**Note:**

\* Functionality of the device from 0°C to +70°C is guaranteed by production testing. Performance from -40°C to +85°C is guaranteed by characterization and periodic sampling of production units.

CONNECTION DIAGRAMS

Top View

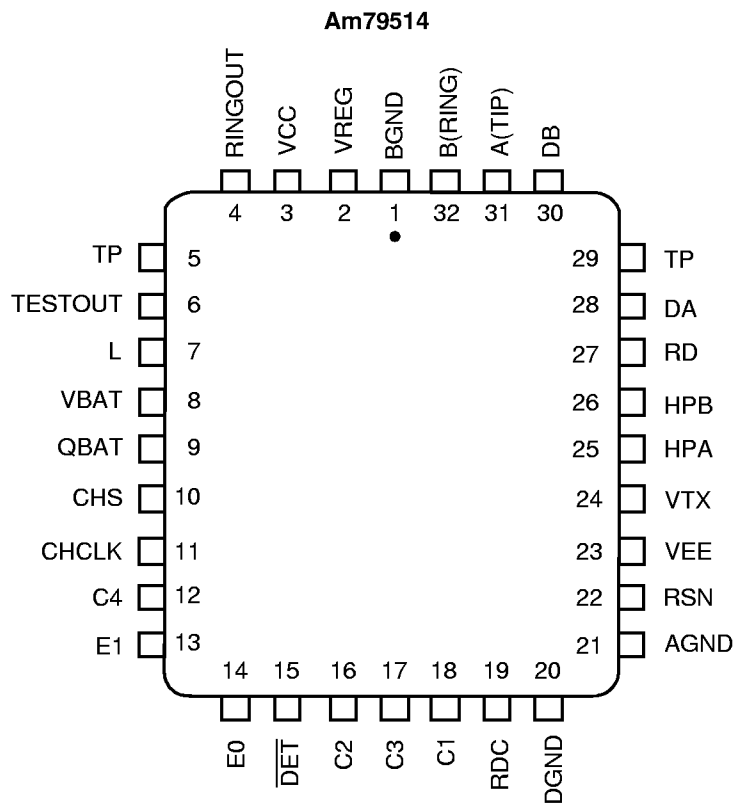

**Notes:**

1. Pin 1 is marked for orientation.
2. TP is a thermal conduction pin tied to substrate.

## PIN DESCRIPTIONS

Pin Names	Type	Description
AGND	Gnd	Analog ground.
A(TIP)	Output	Output of A(TIP) power amplifier.
BGND	Gnd	Battery (power) ground.
B(RING)	Output	Output of B(RING) power amplifier.
C3–C1	Inputs	Decoder. TTL compatible. C3 is MSB and C1 is LSB.
C4	Input	Test relay driver command. TTL compatible. A logic High enables the driver.
DGND	Gnd	Digital ground.
CHCLK	Input	Chopper clock. Input to switching regulator (TTL compatible) Frequency = 256 kHz (nominal).
CHS	Input	Chopper stabilization. Connection for external stabilization components.
DA	Input	Ring-Trip negative. Negative input to ring-trip comparator.
DB	Input	Ring-Trip positive. Positive input to ring-trip comparator.
DET	Output	Detector. When enabled, a logic Low indicates that the selected detector is tripped. The detector is selected by the logic inputs (C3–C1 and E1). The output is open-collector with a built-in 15 k $\Omega$ pull-up resistor.
E0	Input	Read enable. A logic High enables $\overline{\text{DET}}$ . A logic Low disables $\overline{\text{DET}}$ .
E1	Input	Ground key enable. E1 = High connects the ground-key detector to $\overline{\text{DET}}$ , and E1 = Low connects the off-hook or ring-trip detector to $\overline{\text{DET}}$ .
HPA	Capacitor	High-pass filter capacitor. A(TIP) side of high-pass filter capacitor.
HPB	Capacitor	High-pass filter capacitor. B(RING) side of high-pass filter capacitor.
L	Output	Switching regulator power transistor. Connection point for filter inductor and anode of catch diode. This pin will have up to 60 V of pulse waveform on it and must be isolated from sensitive circuits. Extreme care must be taken to keep the diode connections short because of the high currents and high di/dt.
QBAT	Battery	Quiet battery. Filtered battery supply for the signal processing circuits. An external 100 $\Omega$ , 1/8 $\Omega$ resistor must be connected between QBAT and VBAT pins.
RD	Resistor	Detect resistor. Threshold modification and filter point for the off-hook detector.
RDC	Resistor	DC feed resistor. Connection point for the DC feed current programming network. The other end of the network connects to the receiver summing node (RSN). The sign of $V_{\text{RDC}}$ is negative for normal polarity and positive for reverse polarity.
RINGOUT	Output	Ring relay driver. Sourcing from BGND with internal diode to QBAT.
RSN	Input	Receive summing node. The metallic current (both AC and DC) between A(TIP) and B(RING) is equal to 1000 times the current into this pin. The networks that program receive gain, two-wire impedance, and feed current all connect to this node. This node is extremely sensitive. Care should be taken to route the 256-kHz chopper clock and switch lines away from the RSN node.
TESTOUT	Output	Test relay driver. Sourcing from BGND with internal diode to QBAT.
TP	Thermal	Thermal pin. Connection for heat dissipation. Internally connected to substrate (QBAT). Leave as open circuit or connected to QBAT. In both cases, the TP pins can connect to an area of copper on the board to enhance heat dissipation.
VBAT	Battery	Battery Supply.
VCC	Power	+5 V power supply.
VEE	Power	–5 V power supply.
VREG	Input	Regulated voltage. Provides negative power supply for power amplifiers, connection point for inductor, filter capacitor, and chopper stabilization.
VTX	Output	Transmit audio. This output is a unity gain version of the A(TIP) and B(RING) metallic voltage. The other end of the two-wire input impedance programming network connects here.

## ABSOLUTE MAXIMUM RATINGS

Storage temperature .....	-55°C to +150°C
$V_{CC}$ with respect to AGND/DGND .....	-0.4 V to +7.0 V
$V_{EE}$ with respect to AGND/DGND .....	+0.4 V to -7.0 V
$V_{BAT}$ with respect to AGND/DGND .....	+0.4 V to -70 V
<b>Note:</b> Rise time of $V_{BAT}$ ( $dv/dt$ ) must be limited to 27 V/ $\mu$ s or less when $Q_{BAT}$ bypass = 0.33 $\mu$ F.	
BGND with respect to AGND/DGND..	+1.0 V to -3.0 V
A(TIP) or B(RING) to BGND:	
Continuous .....	-70 V to +1.0 V
10 ms (f = 0.1 Hz) .....	-70 V to +5.0 V
1 $\mu$ s (f = 0.1 Hz) .....	-90 V to +10 V
250 ns (f = 0.1 Hz) .....	-120 V to +15 V
Current from A(TIP) or B(RING).....	$\pm$ 150 mA
Voltage on RINGOUT .....	BGND to 70 V above $Q_{BAT}$
Voltage on TESTOUT .....	BGND to 70 V above $Q_{BAT}$
Current through relay drivers .....	60 mA
Voltage on ring-trip inputs DA and DB .....	$V_{BAT}$ to 0 V
Current into ring-trip inputs.....	$\pm$ 10 mA
Peak current into regulator switch (L pin) .....	150 mA
Switcher transient peak off voltage on L pin .....	+1.0 V
C4-C1, E1, CHCLK, to AGND/DGND .....	-0.4 V to $V_{CC}$ + 0.4 V
Maximum power dissipation, (see note) .....	$T_A = 70^\circ\text{C}$
In 32-pin PLCC package.....	1.74 W

**Note:** Thermal limiting circuitry on chip will shut down the circuit at a junction temperature of about 165°C. The device should never be exposed to this temperature. Operation above 145°C junction temperature may degrade device reliability. See the SLIC Packaging Considerations for more information.

Stresses above those listed under Absolute Maximum Ratings may cause permanent device failure. Functionality at or above these limits is not implied. Exposure to Absolute Maximum Ratings for extended periods may affect device reliability.

## OPERATING RANGES

### Commercial (C) Devices

Ambient temperature .....	0°C to +70°C*
$V_{CC}$ .....	4.75 V to 5.25 V
$V_{EE}$ .....	-4.75 V to -5.25 V
$V_{BAT}$ .....	-40 V to -63 V
AGND/DGND .....	0 V
BGND with respect to AGND/DGND .....	-100 mV to +100 mV
Load resistance on VTX to ground .....	10 k $\Omega$ min

Operating Ranges define those limits between which the functionality of the device is guaranteed.

\* Functionality of the device from 0°C to +70°C is guaranteed by production testing. Performance from -40°C to +85°C is guaranteed by characterization and periodic sampling of production units.

## ELECTRICAL CHARACTERISTICS

Description	Test Conditions (See Note 1)	Min	Typ	Max	Unit	Note
Analog ( $V_{TX}$ ) output impedance			3	20	W	
Analog ( $V_{TX}$ ) output offset	0°C to +70°C -40°C to +85°C	-35 -40		+35 +40	mV	— 4
Analog (RSN) input impedance	300 Hz to 3.4 kHz		1	20	W	
Longitudinal impedance at A or B				35		
Overload level $Z_{2WIN} = 600 \Omega$ to $900 \Omega$	4-wire 2-wire	-3.1 -3.1		+3.1 +3.1	Vpk	2 —
<b>Transmission Performance, 2-Wire Impedance</b>						
2-wire return loss (See Test Circuit D)	300 Hz to 500 Hz 500 Hz to 2500 Hz 2500 Hz to 3400 Hz	26 26 20			dB	4 — —
<b>Longitudinal Balance (2-Wire and 4-Wire, See Test Circuit C)</b>						
Longitudinal to metallic L-T, L-4	200 Hz to 1 kHz: normal polarity	-1*	50		dB	5
	0°C to +70°C	-2	63			
	normal polarity	-2	58			
	-40°C to +85°C	-2	58			
	reverse polarity	-2	58			
	1 kHz to 3.4 kHz: normal polarity	-1*	52			
	0°C to +70°C	-2	58			
	normal polarity	-2	54			
-40°C to +85°C	-2	54				
reverse polarity	-2	54				
Longitudinal sum (L-T) + (T-L)	300 to 3400 Hz	95				
Longitudinal signal generation 4-L or T-L	300 to 800 Hz 800 to 3400 Hz	40 35				
Longitudinal current capability per wire	Active state OHT state			17 8	mArms	
<b>Insertion Loss (2- to 4-Wire and 4- to 2-Wire, See Test Circuits A and B)</b>						
Gain accuracy	0 dBm, 1 kHz, 0°C to +70°C	-0.15		+0.15	dB	4
	0 dBm, 1 kHz, -40°C to +85°C	-0.20		+0.20		
	0 dBm, 1 kHz, 0°C to +70°C	-1*	-0.1	+0.1		
	0 dBm, 1 kHz, -40°C to +85°C	-1	-0.15	+0.15		
Variation with frequency	300 Hz to 3400 Hz Relative to 1 kHz 0°C to +70°C -40°C to +85°C	-0.1 -0.15		+0.1 +0.15		4
Gain tracking	+7 dBm to -55 dBm 0°C to +70°C -40°C to +85°C	-0.1 -0.15		+0.1 +0.15		

**Note:**

\* P.G. = Performance Grade

## ELECTRICAL CHARACTERISTICS (CONTINUED)

Description	Test Conditions (See Note 1)	Min	Typ	Max	Unit	Note
<b>Balance Return Signal (4-Wire to 4-Wire, See Test Circuit B)</b>						
Gain accuracy	0 dBm, 1 kHz, 0°C to +70°C	-0.15		+0.15	dB	4
	0 dBm, 1 kHz, -40°C to +85°C	-0.20		+0.20		
	0 dBm, 1 kHz, 0°C to +70°C	-1*	-0.1	+0.1		
	0 dBm, 1 kHz, -40°C to +85°C	-1	-0.15	+0.15		
Variation with frequency	300 Hz to 3400 Hz Relative to 1 kHz 0°C to +70°C -40°C to +85°C	-0.1 -0.15		+0.1 +0.15		4
Gain tracking	+7 dBm to -55 dBm 0°C to +70°C -40°C to +85°C	-0.1 -0.15		+0.1 +0.15		
Group delay	f = 1 kHz		5.3		µs	
<b>Total Harmonic Distortion (2- to 4-Wire or 4- to 2-Wire, See Test Circuits A and B)</b>						
Distortion level	0 dBm, 300 Hz to 3400 Hz		-64	-50	dB	
Distortion level	+9 dBm		-55	-40		
<b>Idle Channel Noise</b>						
Psophometric weighted noise	2-wire 0°C to +70°C		-83	-78	dBmp	7
	2-wire -40°C to +85°C		-83	-75		4, 7
	4-wire 0°C to +70°C		-83	-78		7
	4-wire -40°C to +85°C		-83	-75		4, 7
<b>Single Frequency Out-of-Band Noise (See Test Circuit E)</b>						
Metallic	4 kHz to 9 kHz		-76		dBm	4, 5, 9
	9 kHz to 1 MHz		-76			
	256 kHz and harmonics		-57			4, 5
Longitudinal	1 kHz to 15 kHz		-70			4, 5, 9
	Above 15 kHz		-85			
	256 kHz and harmonics		-57			4, 5
<b>DC Feed Current and Voltage (See Figure 1)</b>						
<b>Unless otherwise noted, Battery = 60 V (V<sub>BAT</sub> = -59.3 V)</b>						
Active state loop-current accuracy	I <sub>LOOP</sub> (nominal) = 40 mA		-7.5		% mA mA	4
	R <sub>L</sub> = 2000 Ω, Battery = 62 V	-1*	23	+7.5		
	R <sub>L</sub> = 2080 Ω	-2	22.7			
On-hook loop voltage	R <sub>L</sub> = ∞	47.5	49		V	
OHT state	R <sub>L</sub> = 600 Ω			22	mA	
Tip Open state	R <sub>L</sub> = 600 Ω	18	20	1.0		
Disconnect state	R <sub>L</sub> = 0			1.0		
<b>Power Dissipation, Battery = -60 V</b>						
On-hook Open Circuit state			50	120	mW	
On-hook OHT state			175	250		
On-hook Active state			260	400		
Off-hook OHT state	R <sub>L</sub> = 600 Ω		500	750		
Off-hook Active state	R <sub>L</sub> = 600 Ω		650	1000		

## ELECTRICAL CHARACTERISTICS (CONTINUED)

Description	Test Conditions (See Note 1)	Min	Typ	Max	Unit	Note
<b>Supply Currents</b>						
V <sub>CC</sub> On-hook supply current	Open Circuit state OHT state Active state		3 6 7.5	4.5 10 12	mA	
V <sub>EE</sub> On-hook supply current	Open Circuit state OHT state Active state		1.0 2.2 2.7	2.3 3.5 6.0		
V <sub>BAT</sub> On-hook supply current	Open Circuit state OHT state Active state		0.4 3.0 4.0	1.0 5.0 6.0		
<b>Power Supply Rejection Ratio (V<sub>RIPPLE</sub> = 50 mVrms)</b>						
V <sub>CC</sub>	40 Hz to 3400 Hz 3.4 kHz to 50 kHz	20 20	35 30		dB	6, 7 —
V <sub>EE</sub>	40 Hz to 3400 Hz 3.4 kHz to 50 kHz	20 15	30 25			6, 7 —
V <sub>BAT</sub>	40 Hz to 3400 Hz 3.4 kHz to 50 kHz	27 20	30 30			6, 7 —
<b>Off-Hook Detector</b>						
Current threshold	I <sub>DET</sub> = 365/R <sub>D</sub>	-20		+20	%	
<b>Ground-Key Detector Thresholds Active State, Battery = -60 V</b>						
Ground-key resistance threshold	B(RING) to GND	2.0	4.2	10.0	kΩ	
Ground-key current threshold	B(RING) or midpoint to GND		9		mA	8
<b>Ring-Trip Detector Input</b>						
Bias current		-5	-0.05		μA	
Offset voltage	Source resistance = 0 to 200 kΩ	-50	0	+50	mV	
<b>Logic Inputs (C4-C1, E1, and CHCLK)</b>						
Input High voltage		2.0			V	
Input Low voltage				0.8	μA	
Input High current	All inputs except E1 Input E1	-75 -75		40 45		
Input Low current		-0.4			mA	
<b>Logic Output (DET)</b>						
Output Low voltage	I <sub>OUT</sub> = 0.8 mA			0.4	V	
Output High voltage	I <sub>OUT</sub> = -0.1 mA	2.4				
<b>Relay Driver Outputs (RINGOUT, TESTOUT)</b>						
On voltage	50 mA source	B <sub>GND</sub> -2			V	
Off leakage			0.5	100	μA	
Clamp voltage	50 mA sink	Q <sub>BAT</sub> -2			V	



## RELAY DRIVER SCHEMATICS

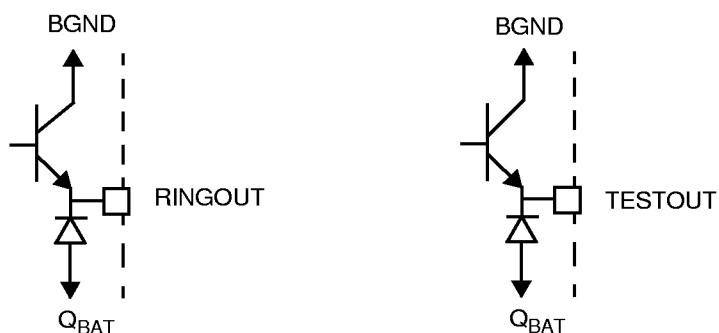

## SWITCHING CHARACTERISTICS

Symbol	Parameter	Test Conditions	Temperature Ranges	Min	Typ	Max	Unit	Note
tgkde	E1 Low to $\overline{\text{DET}}$ High (E0 = 1)	Ground-key Detect state $R_L$ open, $R_G$ connected (See Figure H)	0°C to +70°C			3.8	$\mu\text{s}$	4
			-40°C to +85°C			4.0		
	E1 Low to $\overline{\text{DET}}$ Low (E0 = 1)		0°C to +70°C			1.1		
			-40°C to +85°C			1.6		
tgkdd	E0 High to $\overline{\text{DET}}$ Low (E1 = 0)		0°C to +70°C			1.1		
			-40°C to +85°C			1.6		
tgkd0	E0 Low to $\overline{\text{DET}}$ High (E1 = 0)		0°C to +70°C			3.8		
			-40°C to +85°C			4.0		
tshde	E1 High to $\overline{\text{DET}}$ Low (E0 = 1)	Switchhook Detect state $R_L = 600 \Omega$ , $R_G$ open (See Figure G)	0°C to +70°C			1.2		
			-40°C to +85°C			1.7		
	E1 High to $\overline{\text{DET}}$ High (E0 = 1)		0°C to +70°C			3.8		
			-40°C to +85°C			4.0		
tshdd	E0 High to $\overline{\text{DET}}$ Low (E1 = 1)		0°C to +70°C			1.1		
			-40°C to +85°C			1.6		
tshd0	E0 Low to $\overline{\text{DET}}$ High (E1 = 1)		0°C to +70°C			3.8		
			-40°C to +85°C			4.0		

## SWITCHING WAVEFORMS

E1 to  $\overline{\text{DET}}$

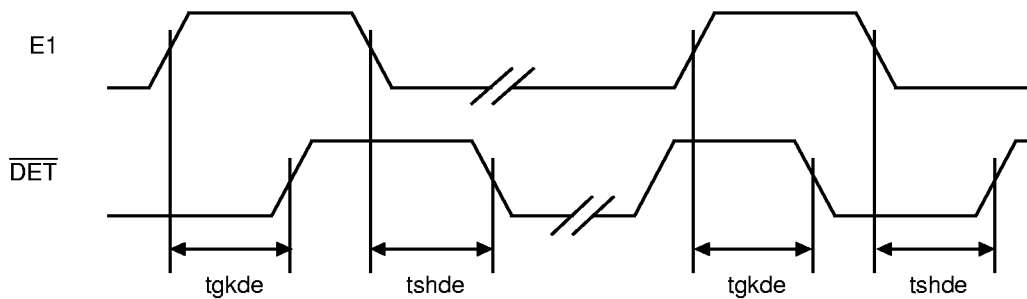

E0 to  $\overline{\text{DET}}$

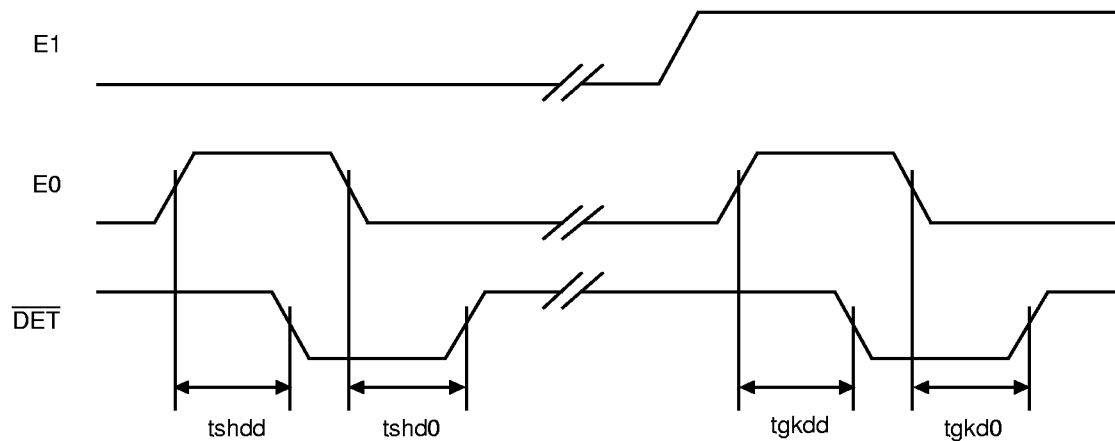

**Note:**

All delays measured at 1.4 V level.

**Notes:**

1. Unless otherwise noted, test conditions are  $BAT = -60\text{ V}$ ,  $V_{CC} = +5\text{ V}$ ,  $V_{EE} = -5\text{ V}$ ,  $R_L = 600\ \Omega$ ,  $C_{HP} = 0.33\ \mu\text{F}$ ,  $R_{DC1} = R_{DC2} = 31.25\ \text{k}\Omega$ ,  $C_{DC} = 0.1\ \mu\text{F}$ ,  $R_d = 51.1\ \text{k}\Omega$ , no fuse resistors, two-wire AC output impedance programming impedance ( $Z_T$ ) =  $600\ \text{k}\Omega$  resistive, receive input summing impedance ( $Z_{RX}$ ) =  $300\ \text{k}\Omega$  resistive. (See Table 2 for component formulas.)
2. Overload level is defined when  $THD = 1\%$ .
3. Balance return signal is the signal generated at  $V_{TX}$  by  $V_{RX}$ . This specification assumes that the two-wire AC load impedance matches the impedance programmed by  $Z_T$ .
4. Not tested in production. This parameter is guaranteed by characterization or correlation to other tests.
5. These tests are performed with a longitudinal impedance of  $90\ \Omega$  and metallic impedance of  $300\ \Omega$  for frequencies below  $12\ \text{kHz}$  and  $135\ \Omega$  for frequencies greater than  $12\ \text{kHz}$ . These tests are extremely sensitive to circuit board layout. Please refer to application notes for details.
6. This parameter is tested at  $1\ \text{kHz}$  in production. Performance at other frequencies is guaranteed by characterization.
7. When the SLIC is in the Anti-Sat 2 operating region, this parameter is degraded. The exact degradation depends on system design. The Anti-Sat 2 region occurs at high loop resistances when  $|V_{BAT}| - |V_{AX} - V_{BX}|$  is less than approximately  $15\ \text{V}$ .
8. "Midpoint" is defined as the connection point between two  $300\ \Omega$  series resistors connected between A(TIP) and B(RING).
9. Fundamental and harmonics from  $256\ \text{kHz}$  switch regulator chopper are not included.

**Table 1. SLIC Decoding**

State	C3 C2 C1	Two-Wire Status	DET Output	
			E1 = 0	E1 = 1
0	0 0 0	Open Circuit	Ring trip	Ring trip
1	0 0 1	Ringling	Ring trip	Ring trip
2	0 1 0	Active	Loop detector	Ground key
3	0 1 1	On-hook TX (OHT)	Loop detector	Ground key
4	1 0 0	Tip Open	Loop detector	—
5	1 0 1	Reserved	Loop detector	—
6	1 1 0	Active Polarity Reversal	Loop detector	Ground key
7	1 1 1	OHT Polarity Reversal	Loop detector	Ground key

**Table 2. User-Programmable Components**

$Z_T = 1000(Z_{2WIN} - 2R_F)$	Where $Z_T$ is connected between the VTX and RSN pins. The fuse resistors are $R_F$ , and $Z_{2WIN}$ is the desired 2-wire AC input impedance. When computing $Z_T$ , the internal current amplifier pole and any external stray capacitance between VTX and RSN must be taken into account.
$Z_{RX} = \frac{Z_L}{G_{42L}} \cdot \frac{1000 \cdot Z_T}{Z_T + 1000(Z_L + 2R_F)}$	Where $Z_{RX}$ is connected from $V_{RX}$ to the RSN pin, $Z_T$ is defined above, $G_{42L}$ is the desired receive gain, and $Z_L$ is the 2-wire load impedance.
$R_{DC1} + R_{DC2} = \frac{2500}{I_{FEED}}$	Where $R_{DC1}$ , $R_{DC2}$ , and $C_{DC}$ form the network $C_{DC} = (1.5 \text{ ms})(R_{DC1} + R_{DC2}) / (R_{DC1} \cdot R_{DC2})$ connected to the RDC pin. $R_{DC1}$ and $R_{DC2}$ are approximately equal.
$R_D = \frac{365}{I_T}, \quad C_D = \frac{0.5 \text{ ms}}{R_D}$	Where $R_D$ and $C_D$ form the network connected from RD to $-5 \text{ V}$ and $I_T$ is the threshold current between on hook and off hook.

DC FEED CHARACTERISTICS

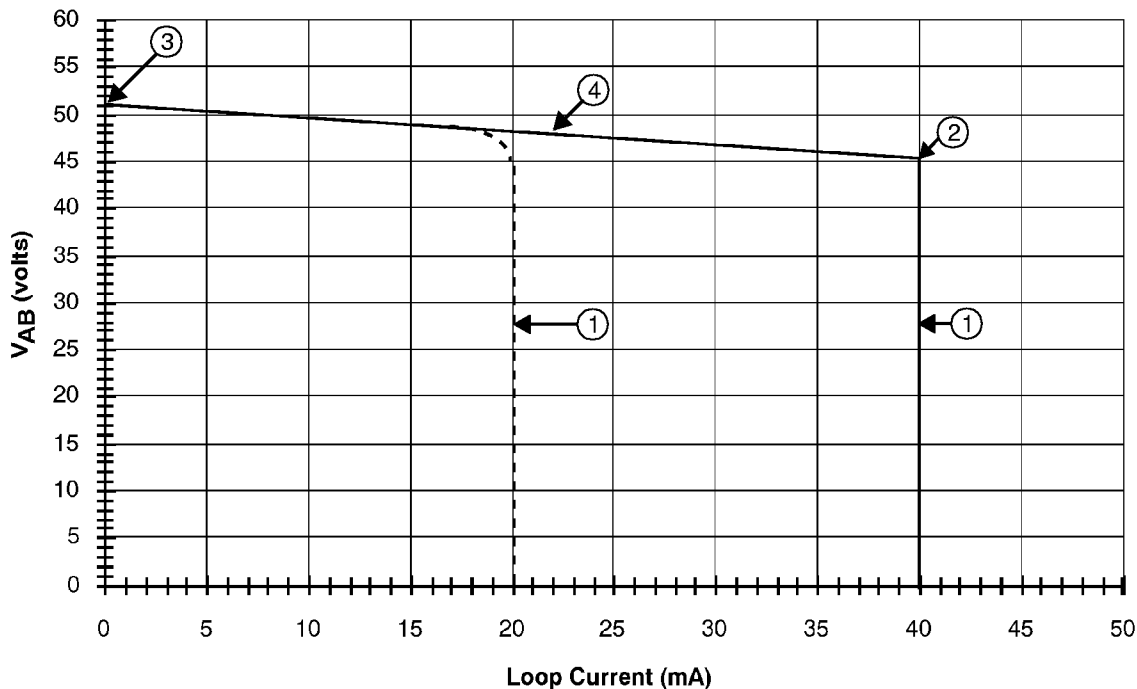

V<sub>BAT</sub> = 62.3 V  
R<sub>DC</sub> = 62.5 kΩ

———— Active state  
- - - - - OHT state

Notes:

1. Constant-current region:

Active state,  $I_L = \frac{2500}{R_{DC}}$

OHT state,  $I_L = \frac{1}{2} \cdot \frac{2500}{R_{DC}}$

2. Anti-sat cut-in:  $V_{AB} = 46 \text{ V}, \quad |V_{BAT}| \geq 58.9 \text{ V}$

$V_{AB} = 1.087|V_{BAT}| - 18.017, \quad |V_{BAT}| < 58.9 \text{ V}$

3. Open Circuit voltage:  $V_{AB} = 51.23 \text{ V}, \quad |V_{BAT}| \geq 61.5 \text{ V}$

$V_{AB} = 1.073|V_{BAT}| - 14.72, \quad |V_{BAT}| < 61.5 \text{ V}$

4. Anti-sat 1 region:  $V_{AB} = 51.23 - I_L \frac{R_{DC}}{488.3}$

5. Anti-sat 2 region:  $V_{AB} = 1.073|V_{BAT}| - 14.72 - I_L \frac{R_{DC}}{1071}$

a. V<sub>A</sub>-V<sub>B</sub> (V<sub>AB</sub>) Voltage vs. Loop Current (Typical)

DC FEED CHARACTERISTICS (continued)

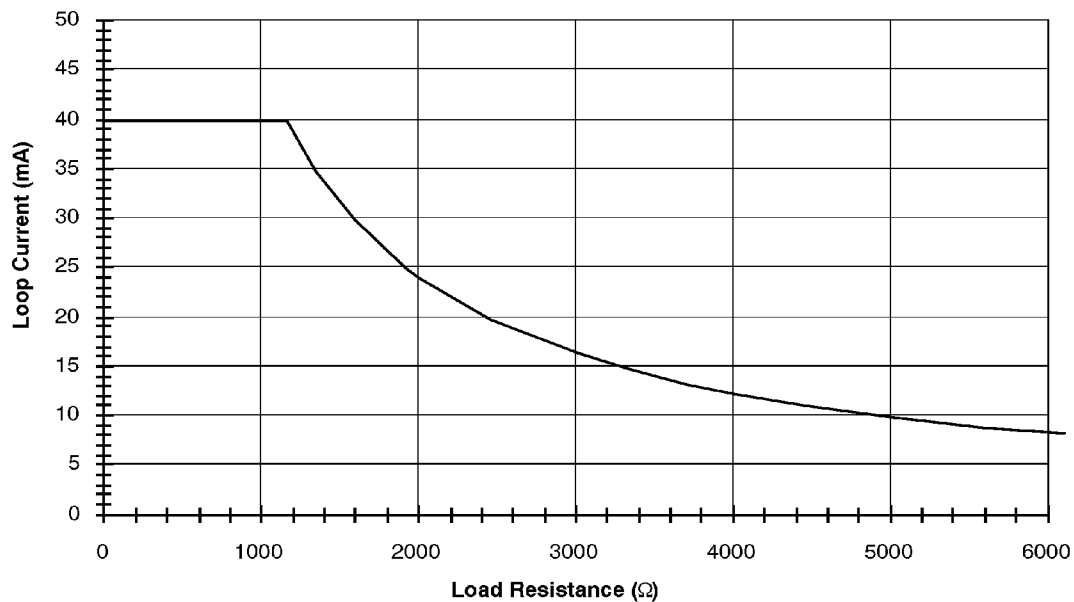

$V_{BAT} = 62.3 V$

$R_{DC} = 62.5 k\Omega$

b. Loop Current vs. Load Resistance (Typical)

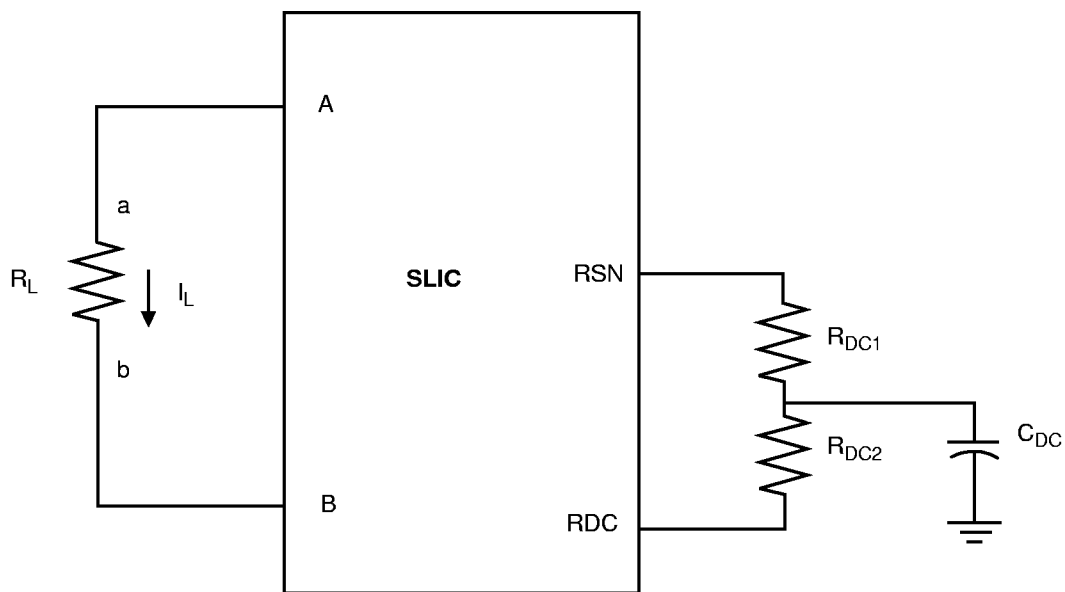

Feed current programmed by  $R_{DC1}$  and  $R_{DC2}$

c. Feed Programming

Figure 1. DC Feed Characteristics

TEST CIRCUITS

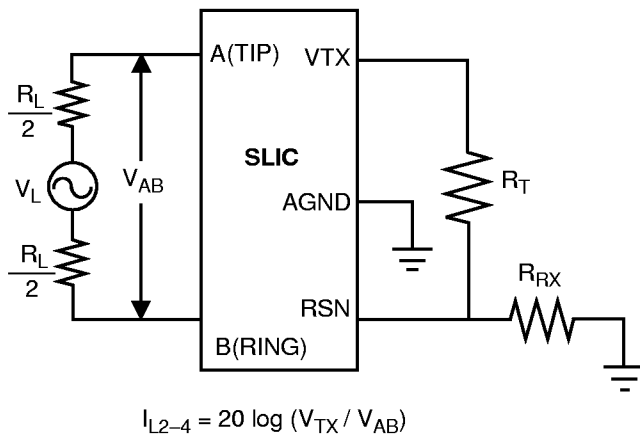

A. Two- to Four-Wire Insertion Loss

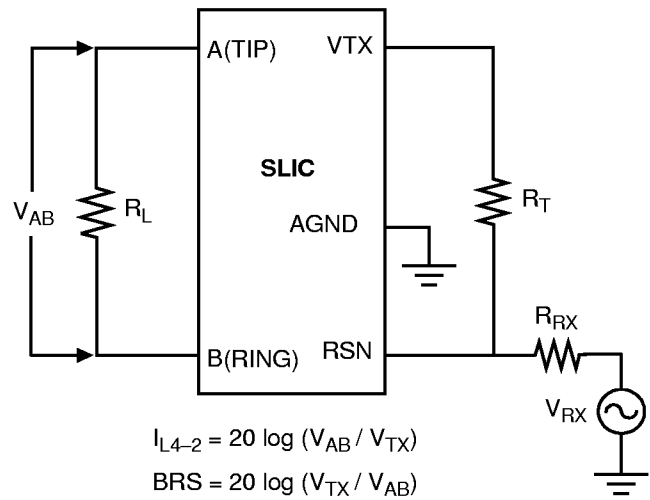

B. Four- to Two-Wire Insertion Loss and Balance Return Signal

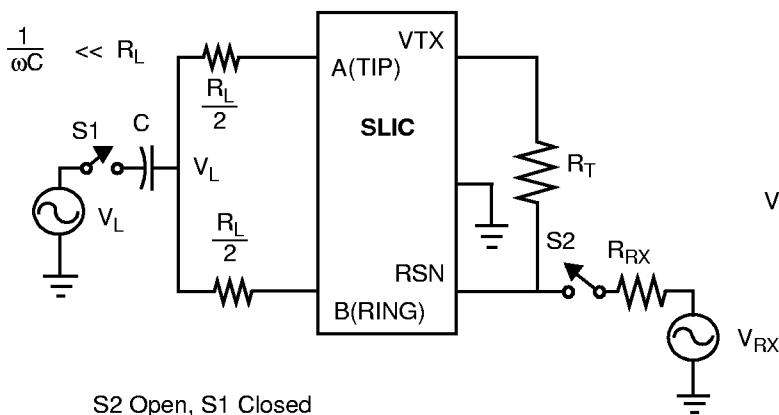

S2 Open, S1 Closed  
 L-T Long. Bal. =  $20 \log (V_{AB} / V_L)$   
 L-4 Long. Bal. =  $20 \log (V_{TX} / V_L)$

S2 Closed, S1 Open  
 4-L Long. Sig. Gen. =  $20 \log (V_L / V_{RX})$

C. Longitudinal Balance

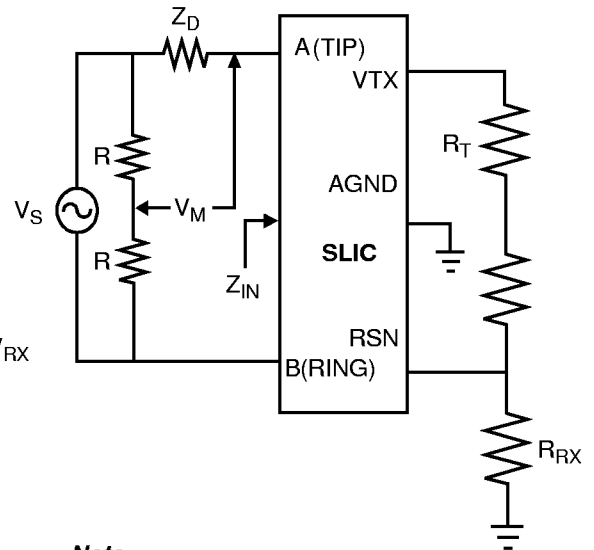

**Note:**  
*Z<sub>D</sub> is the desired impedance (e.g., the characteristic impedance of the line).*

$R_L = -20 \log (2 V_M / V_S)$

D. Two-Wire Return Loss Test Circuit

TEST CIRCUITS (continued)

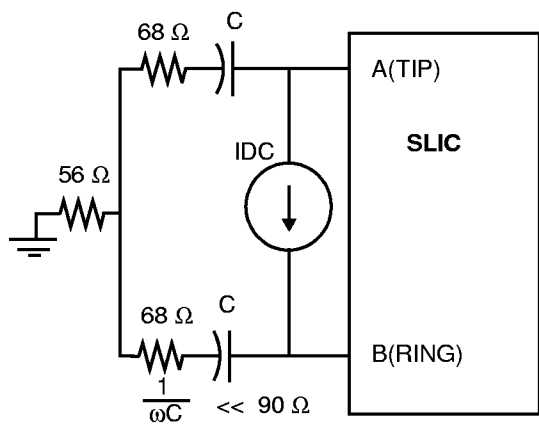

E. Single-Frequency Noise

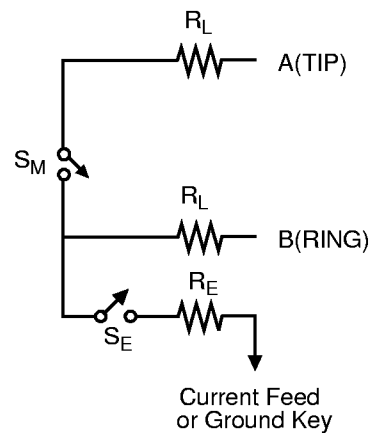

F. Ground-Key Detection

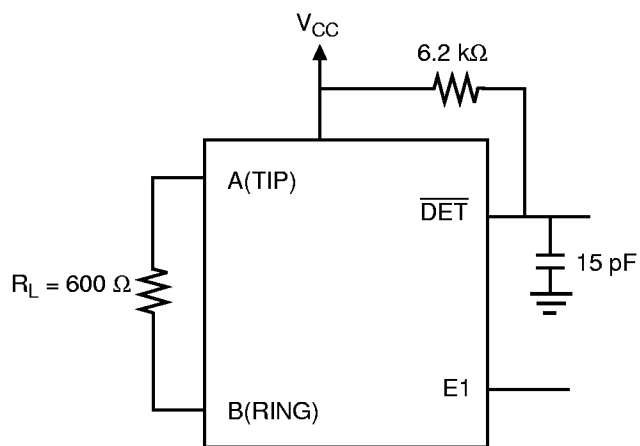

G. Loop-Detector Switching

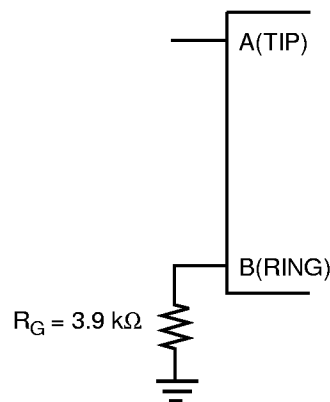

H. Ground-Key Switching

## PHYSICAL DIMENSION

PL032

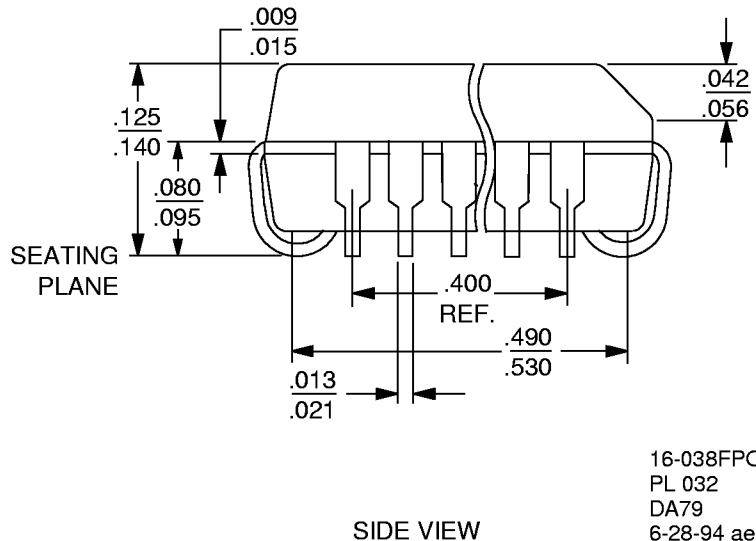
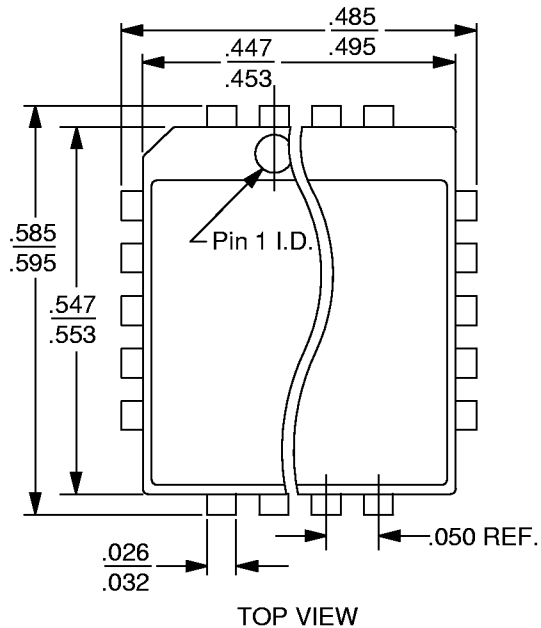

16-038FPO-5  
 PL 032  
 DA79  
 6-28-94 ae

## REVISION SUMMARY

### Revision A to Revision B

- Minor changes were made to the data sheet style and format to conform to AMD standards.

### Revision B to Revision C

- In Pin Description table, inserted/changed TP pin description to: "Thermal pin. Connection for heat dissipation. Internally connected to substrate (QBAT). Leave as open circuit or connected to QBAT. In both cases, the TP pins can connect to an area of copper on the board to enhance heat dissipation."
- Minor changes were made to the data sheet style and format to conform to AMD standards.

### Revision C to Revision D

- The physical dimension (PL032) was added to the Physical Dimension section.
- Deleted the Ceramic DIP and Plastic DIP part (Am79512) and references to them.
- Updated Pin Description table to correct inconsistencies.