

# NPN SILICON RF POWER TRANSISTOR

**DESCRIPTION:**

The **ASI AVF150** is a high power Class C transistor, Designed for IFF/DME/TACAN Applications in 960-1215 MHz.

**FEATURES:**

- Internal Input/Output Matching Networks
- $P_G = 8.2$  dB at 150 W/1150 MHz
- **Omnigold™** Metalization System
- 30:1 load VSWR capability

**MAXIMUM RATINGS**

$I_C$	11 A
$V_{CC}$	55 V
$P_{DISS}$	400 W @ $T_C = 25$ °C
$T_J$	-65 °C to +250 °C
$T_{STG}$	-65 °C to +200 °C
$\theta_{JC}$	0.6 °C/W

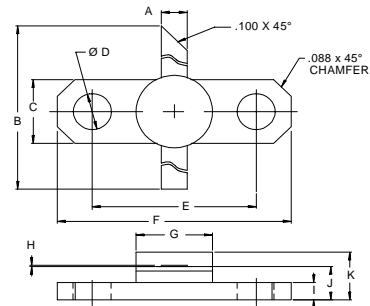
**PACKAGE STYLE .250 2L FLG (B)**

DIM	MINIMUM inches / mm	MAXIMUM inches / mm
A	.095 / 2.41	.105 / 2.67
B	1.050 / 26.67	
C	.245 / 6.22	.255 / 6.48
D	.120 / 3.05	.140 / 3.56
E	.552 / 14.02	.572 / 14.53
F	.790 / 20.07	.810 / 20.57
G		.285 / 7.24
H	.003 / 0.08	.007 / 0.18
I	.052 / 1.32	.072 / 1.83
J	.120 / 3.05	.130 / 3.30
K		.210 / 5.33

**ORDER CODE: ASI10570**
**CHARACTERISTICS**  $T_C = 25$  °C

SYMBOL	TEST CONDITIONS	MINIMUM	TYPICAL	MAXIMUM	UNITS
$BV_{CBO}$	$I_C = 10$ mA	65			V
$BV_{CES}$	$I_C = 25$ mA	65			V
$BV_{EBO}$	$I_E = 1.0$ mA	3.5			V
$I_{CES}$	$V_{CE} = 50$ V			10.5	mA
$h_{FE}$	$V_{CE} = 5.0$ V $I_C = 300$ mA	5.0		120	---
$P_G$	$V_{CC} = 50$ V $P_{OUT} = 150$ W $f = 1025 - 1150$ MHz	8.5			dB
$\eta_c$		40			%