

## 600kHz/1.2MHz PWM Step-Up Regulator



The EL7516 is a high frequency, high efficiency step-up voltage regulator operated at constant frequency PWM

mode. With an internal 1.5A, 200mΩ MOSFET, it can deliver up to 600mA output current at over 90% efficiency. The selectable 600kHz and 1.2MHz allows smaller inductors and faster transient response. An external compensation pin gives the user greater flexibility in setting frequency compensation allowing the use of low ESR Ceramic output capacitors.

When shut down, it draws < 10μA of current and can operate down to 2.5V input supply. These features along with 1.2MHz switching frequency makes it an ideal device for portable equipment and TFT-LCD displays.

The EL7516 is available in an 8-pin MSOP package with a maximum height of 1.1mm. The device is specified for operation over the full -40°C to +85°C temperature range.

### Pinout

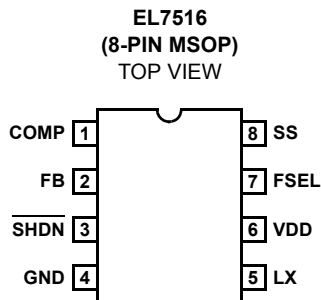

### Features

- > 90% efficiency
- 1.6A, 200mΩ power MOSFET
- $V_{IN} > 2.5V$
- 600kHz/1.2MHz switching frequency selection
- Adjustable soft-start
- Internal thermal protection
- 1.1mm max height 8-pin MSOP package
- Pb-free Available

### Applications

- TFT-LCD displays
- DSL modems
- PCMCIA cards
- Digital cameras
- GSM/CDMA phones
- Portable equipment
- Hand-held devices

### Ordering Information

PART NUMBER	PACKAGE	TAPE & REEL	PKG. DWG. #
EL7516IYZ (See Note)	8-Pin MSOP (Pb-free)	-	MDP0043
EL7516IYZ-T7 (See Note)	8-Pin MSOP (Pb-free)	7"	MDP0043
EL7516IYZ-T13 (See Note)	8-Pin MSOP (Pb-free)	13"	MDP0043

NOTE: Intersil Pb-free products employ special Pb-free material sets; molding compounds/die attach materials and 100% matte tin plate termination finish, which is compatible with both SnPb and Pb-free soldering operations. Intersil Pb-free products are MSL classified at Pb-free peak reflow temperatures that meet or exceed the Pb-free requirements of IPC/JEDEC J Std-020B.

**Absolute Maximum Ratings** ( $T_A = 25^\circ\text{C}$ )

LX to GND	.....18V	Storage Temperature	.....-65°C to +150°C
V <sub>DD</sub> to GND	......6V	Operating Ambient Temperature	.....-40°C to +85°C
COMP, FB, SHDN, SS, FSEL to GND	..... -0.3V to (V <sub>DD</sub> +0.3V)	Operating Junction Temperature	..... +135°C

CAUTION: Stresses above those listed in "Absolute Maximum Ratings" may cause permanent damage to the device. This is a stress only rating and operation of the device at these or any other conditions above those indicated in the operational sections of this specification is not implied.

IMPORTANT NOTE: All parameters having Min/Max specifications are guaranteed. Typical values are for information purposes only. Unless otherwise noted, all tests are at the specified temperature and are pulsed tests, therefore:  $T_J = T_C = T_A$

**Electrical Specifications**  $V_{IN} = 3.3\text{V}$ ,  $V_{OUT} = 12\text{V}$ ,  $I_{OUT} = 0\text{mA}$ ,  $FSEL = GND$ ,  $T_A = 25^\circ\text{C}$  unless otherwise specified.

PARAMETER	DESCRIPTION	CONDITIONS	MIN	TYP	MAX	UNIT
IQ1	Quiescent Current - Shut-down	$\overline{SHDN} = 0\text{V}$		0.6	10	$\mu\text{A}$
IQ2	Quiescent Current - Not Switching	$\overline{SHDN} = V_{DD}$ , $FB = 1.3\text{V}$		0.7		$\text{mA}$
IQ3	Quiescent Current - Switching	$\overline{SHDN} = V_{DD}$ , $FB = 1.0\text{V}$		1.3	2	$\text{mA}$
V <sub>FB</sub>	Feedback Voltage		1.272	1.294	1.309	V
I <sub>B-FB</sub>	Feedback Input Bias Current			0.01	0.5	$\mu\text{A}$
V <sub>DD</sub>	Start-Up Input Voltage Range		2.6		5.5	V
D <sub>MAX-600kHz</sub>	Maximum Duty Cycle	$FSEL = 0\text{V}$	84	90		%
D <sub>MAX-1.2MHz</sub>	Maximum Duty Cycle	$FSEL = V_{DD}$	84	90		%
I <sub>LIM</sub>	Current Limit - Max Peak Input Current		1.3	1.5		A
I <sub>SHDN</sub>	Shut-down Input Bias Current	$\overline{SHDN} = 0\text{V}$		0.01	0.1	$\mu\text{A}$
R <sub>DS-ON</sub>	Switch ON Resistance	$V_{DD} = 2.7\text{V}$ , $I_{LX} = 1\text{A}$		0.2		$\Omega$
I <sub>LX-LEAK</sub>	Switch Leakage Current	$V_{SW} = 18\text{V}$		0.01	3	$\mu\text{A}$
$\Delta V_{OUT}/\Delta V_{IN}$	Line Regulation	$3\text{V} < V_{IN} < 5.5\text{V}$ , $V_{OUT} = 12\text{V}$		0.1		%
$\Delta V_{OUT}/\Delta I_{OUT}$	Load Regulation	$V_{IN} = 3.3\text{V}$ , $V_{OUT} = 12\text{V}$ , $I_O = 30\text{mA}$ to $200\text{mA}$		6.7		$\text{mV/A}$
F <sub>OSC1</sub>	Switching Frequency Accuracy	$FSEL = 0\text{V}$	500	620	740	$\text{kHz}$
F <sub>OSC2</sub>	Switching Frequency Accuracy	$FSEL = V_{DD}$	1000	1250	1500	$\text{kHz}$
V <sub>IL</sub>	$\overline{SHDN}$ , FSEL Input Low Level				0.5	V
V <sub>IH</sub>	$\overline{SHDN}$ , FSEL Input High Level		2.7			V
G <sub>M</sub>	Error Amp Transconductance	$\Delta I = 5\mu\text{A}$	90	130	170	$1\mu/\Omega$
A <sub>V</sub>	Voltage Gain			350		V/V
V <sub>DD-ON</sub>	V <sub>DD</sub> UVLO On Threshold		2.40	2.51	2.60	V
V <sub>DD-OFF</sub>	V <sub>DD</sub> UVLO Off Threshold		2.20	2.30	2.40	V
I <sub>SS</sub>	Soft-start Charge Current		4	6	8	$\mu\text{A}$
R <sub>CS</sub>	Current Sense Transresistance			0.08		V/A

Block Diagram

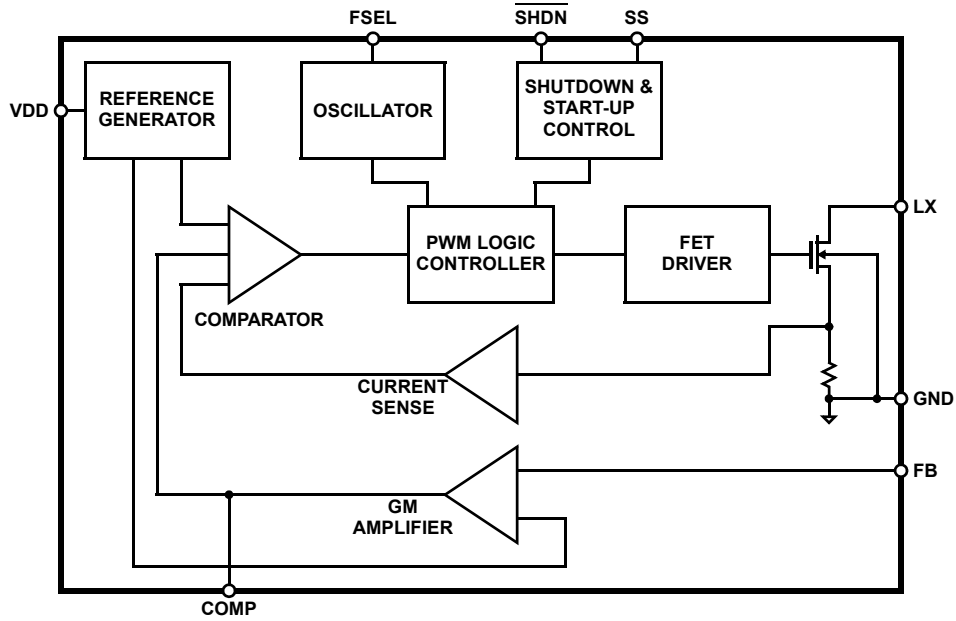

Pin Descriptions

PIN NUMBER	PIN NAME	DESCRIPTION
1	COMP	Compensation pin. Output of the internal error amplifier. Capacitor and resistor from COMP pin to ground.
2	FB	Voltage feedback pin. Internal reference is 1.263V nominal. Connect a resistor divider from $V_{OUT}$ . $V_{OUT} = 1.26V (1 + R_1 / R_2)$ . See Typical Application Circuit.
3	$\overline{\text{SHDN}}$	Shutdown control pin. Pull $\overline{\text{SHDN}}$ low to turn off the device.
4	GND	Analog and power ground.
5	LX	Power switch pin. Connected to the drain of the internal power MOSFET.
6	VDD	Analog power supply input pin.
7	FSEL	Frequency select pin. When FSEL is set low, switching frequency is set to 600kHz. When connected to high or $V_{DD}$ , switching frequency is set to 1.2MHz.
8	SS	Soft-start control pin. Connect a capacitor to control the converter start-up.

Typical Application Circuit

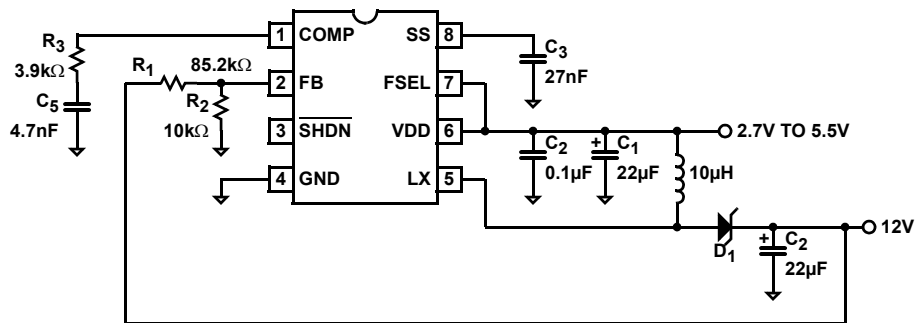

Typical Performance Curves

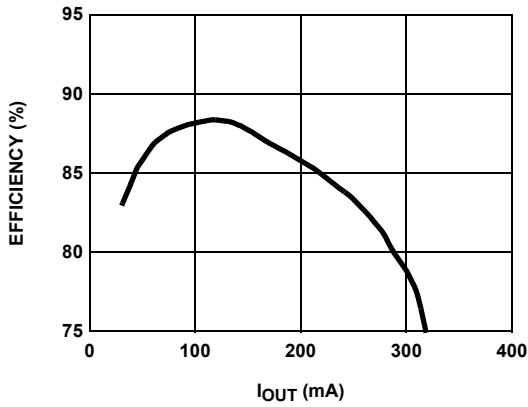

FIGURE 1. EFFICIENCY - 3.3V  $V_{IN}$  TO 12V  $V_{OUT}$  @ 1.3MHz

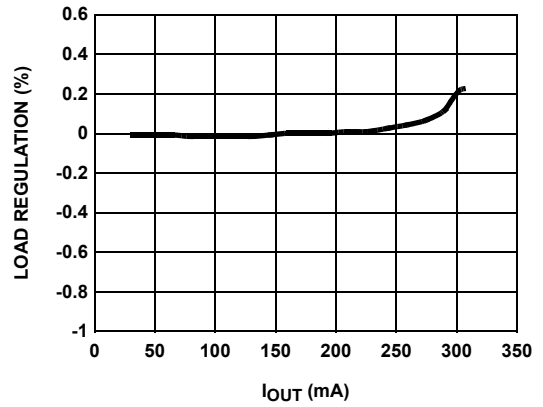

FIGURE 2. LOAD REGULATION - 3.3V  $V_{IN}$  TO 12V  $V_{OUT}$  @ 1.3MHz

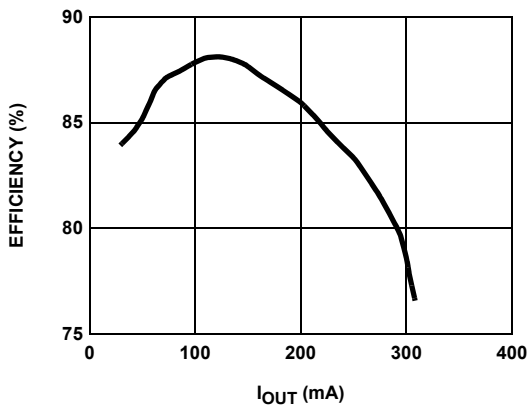

FIGURE 3. EFFICIENCY - 3.3V  $V_{IN}$  TO 12V  $V_{OUT}$  @ 620kHz

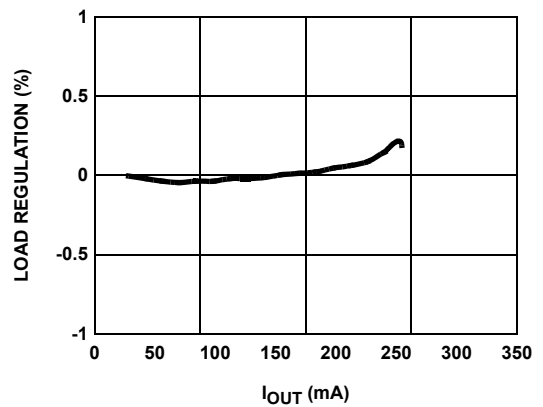

FIGURE 4. LOAD REGULATION - 3.3V  $V_{IN}$  TO 12V  $V_{OUT}$  @ 620kHz

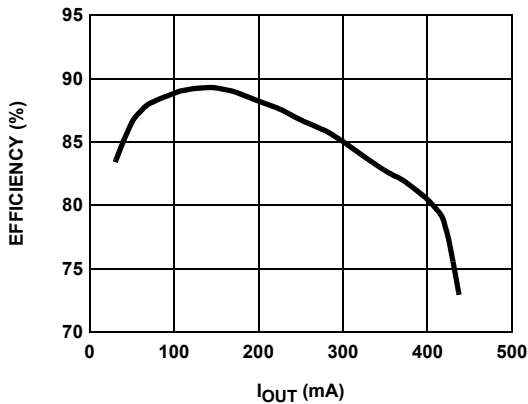

FIGURE 5. EFFICIENCY - 3.3V  $V_{IN}$  TO 9V  $V_{OUT}$  @ 1.2MHz

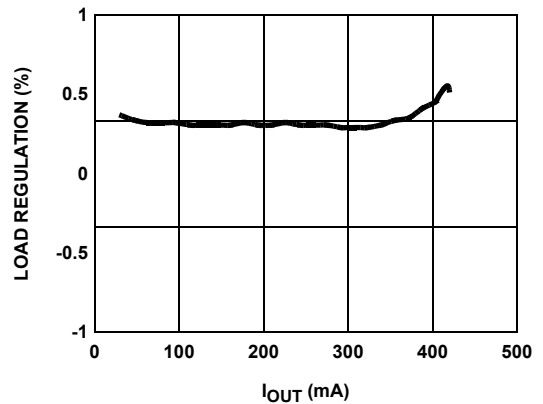

FIGURE 6. LOAD REGULATION - 3.3V  $V_{IN}$  TO 9V  $V_{OUT}$  @ 1.2MHz

Typical Performance Curves (Continued)

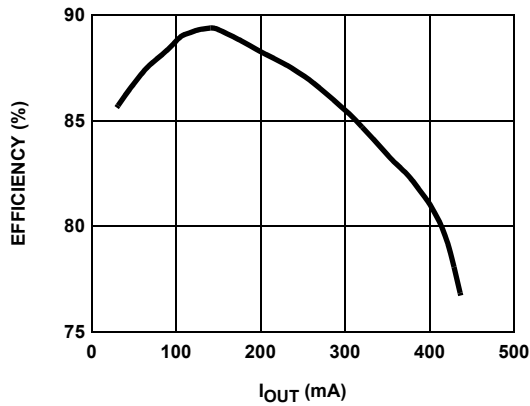

FIGURE 7. EFFICIENCY - 3.3V  $V_{IN}$  TO 9V  $V_{OUT}$  @ 600kHz

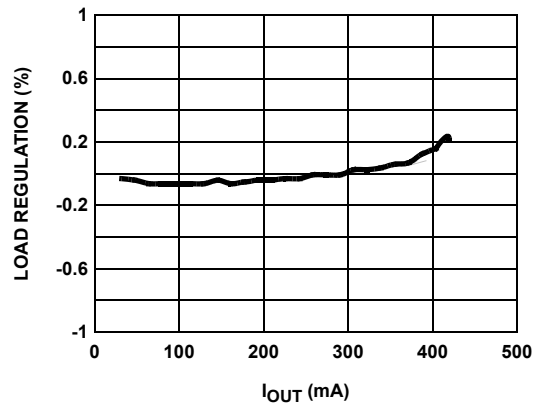

FIGURE 8. LOAD REGULATION - 3.3V  $V_{IN}$  TO 9V  $V_{OUT}$  @ 600kHz

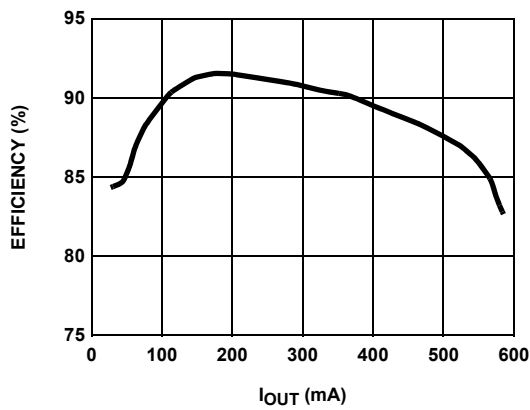

FIGURE 9. EFFICIENCY - 5V  $V_{IN}$  TO 12V  $V_{OUT}$  @ 1.2MHz

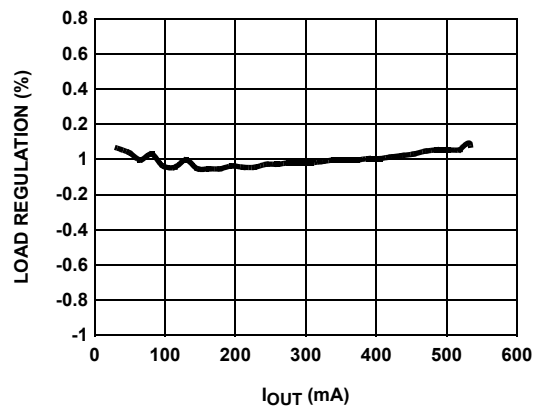

FIGURE 10. LOAD REGULATION - 5V  $V_{IN}$  TO 12V  $V_{OUT}$  @ 1.2MHz

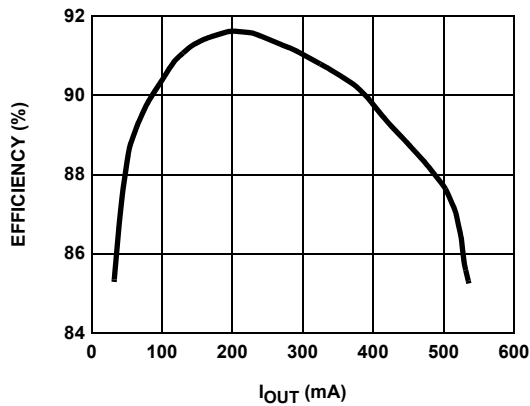

FIGURE 11. EFFICIENCY - 5V  $V_{IN}$  TO 12V  $V_{OUT}$  @ 600kHz

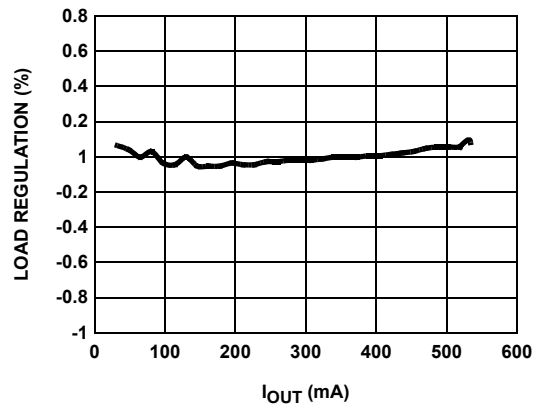

FIGURE 12. LOAD REGULATION - 5V  $V_{IN}$  TO 12V  $V_{OUT}$  @ 600kHz

Typical Performance Curves (Continued)

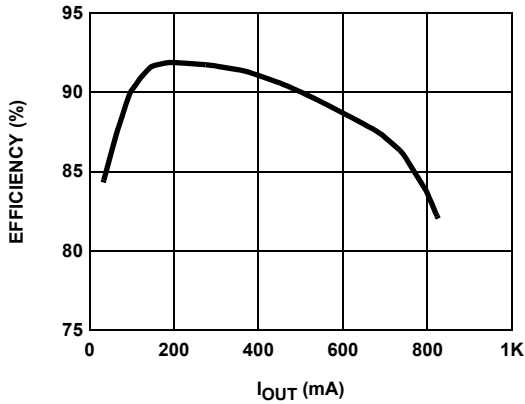

FIGURE 13. EFFICIENCY - 5V  $V_{IN}$  TO 9V  $V_{OUT}$  @ 1.2MHz

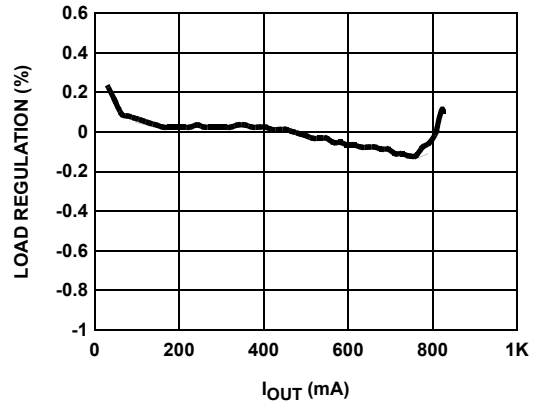

FIGURE 14. LOAD REGULATION - 5V  $V_{IN}$  TO 9V  $V_{OUT}$  @ 1.2MHz

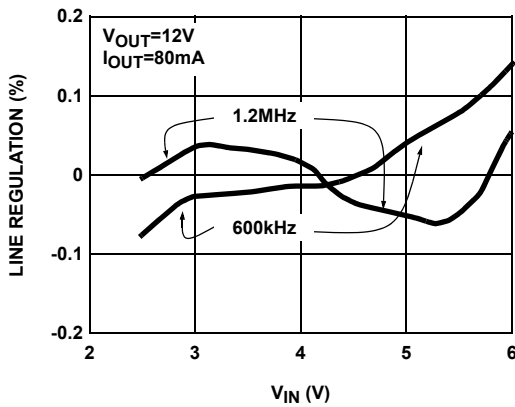

FIGURE 15. LINE REGULATION

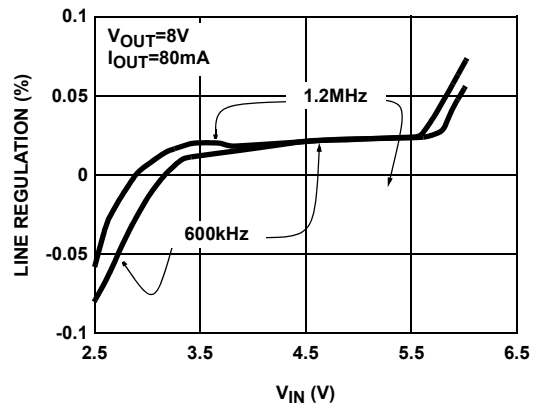

FIGURE 16. LINE REGULATION

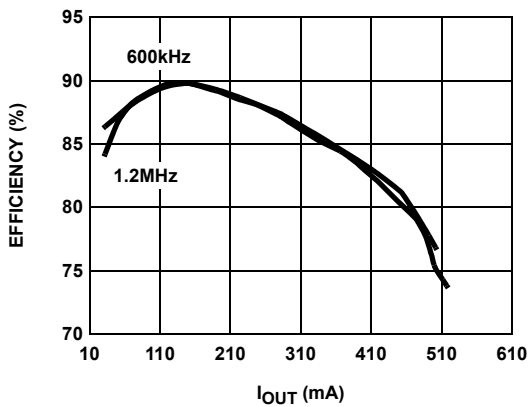

FIGURE 17. EFFICIENCY vs  $I_{OUT}$  - 3.3V TO 8V

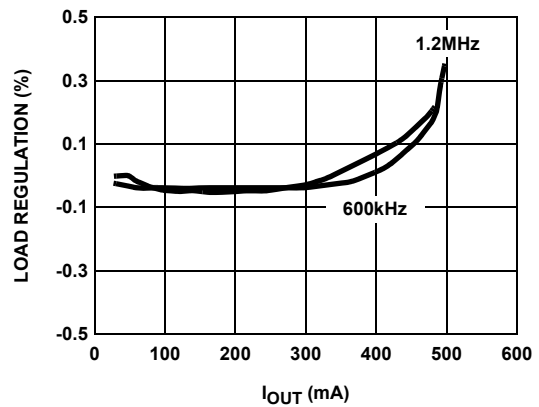

FIGURE 18. LOAD REGULATION - 3.3V TO 8V

Typical Performance Curves (Continued)

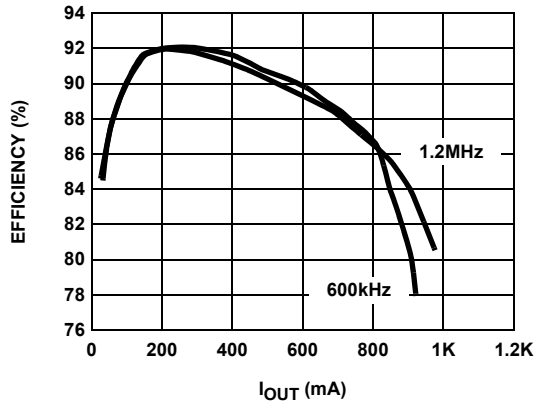

FIGURE 19. EFFICIENCY vs I<sub>OUT</sub>

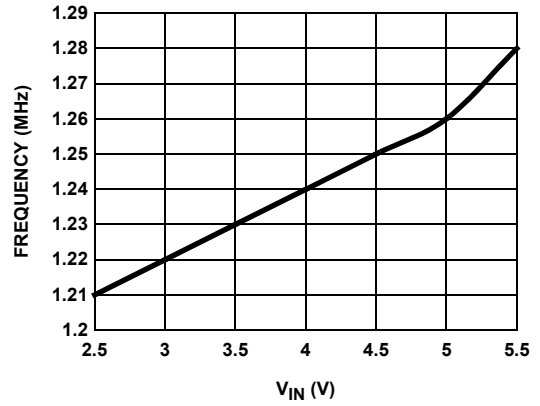

FIGURE 20. FREQUENCY (1.2MHz) vs V<sub>IN</sub>

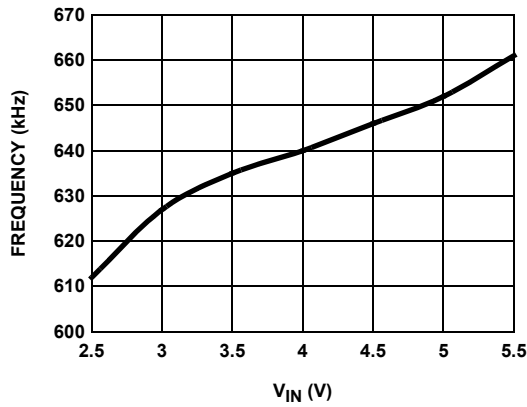

FIGURE 21. FREQUENCY (600kHz) vs V<sub>IN</sub>

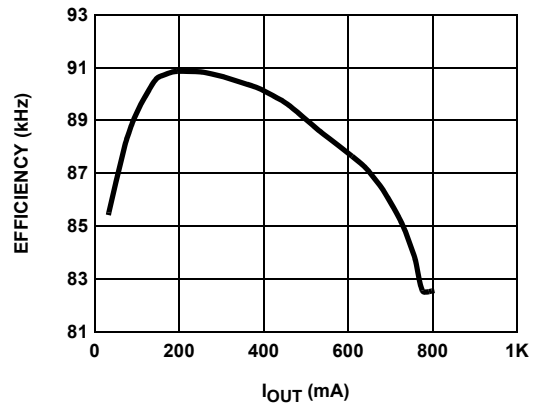

FIGURE 22. EFFICIENCY - 5V V<sub>IN</sub> TO 9V V<sub>OUT</sub> @ 600kHz

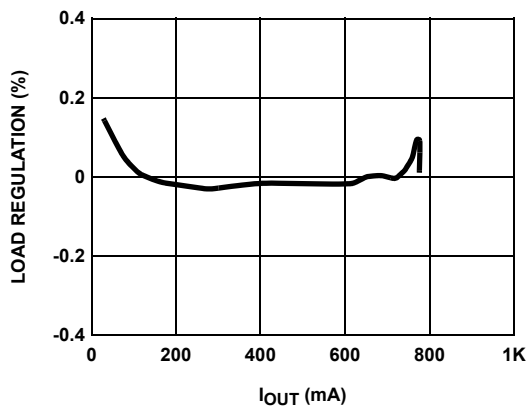

FIGURE 23. LOAD REGULATION - 5V V<sub>IN</sub> TO 9V V<sub>OUT</sub> @ 600kHz

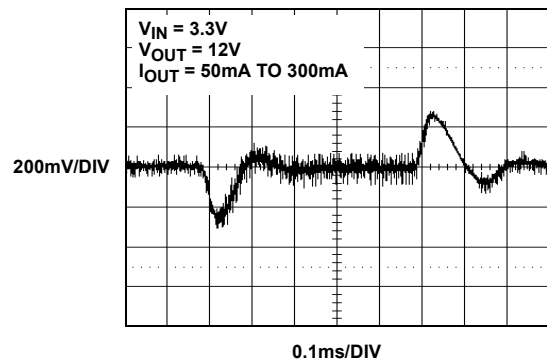

FIGURE 24. TRANSIENT REPOSE - 600kHz

Typical Performance Curves (Continued)

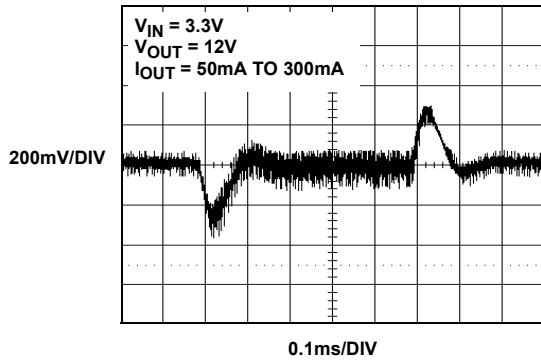

FIGURE 25. TRANSIENT RESPONSE - 1.2MHz

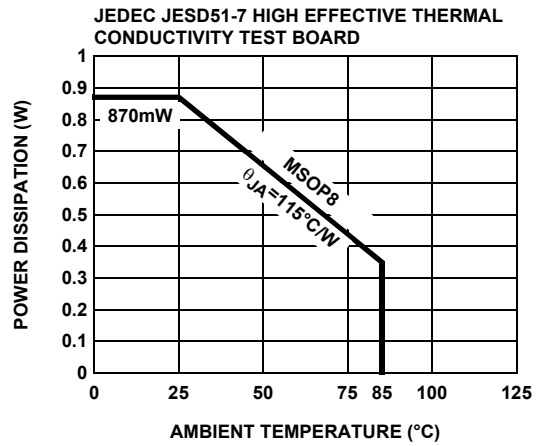

FIGURE 26. PACKAGE POWER DISSIPATION vs AMBIENT TEMPERATURE

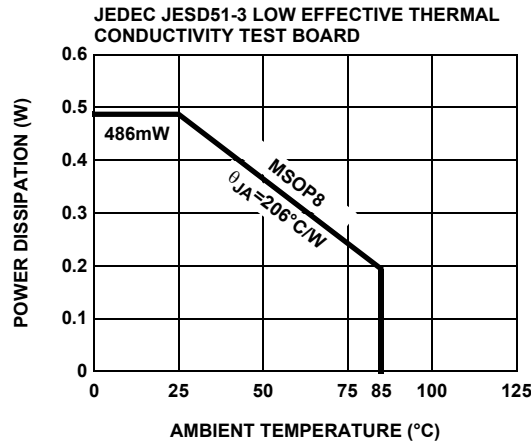

FIGURE 27. PACKAGE POWER DISSIPATION vs AMBIENT TEMPERATURE

All Intersil U.S. products are manufactured, assembled and tested utilizing ISO9000 quality systems. Intersil Corporation's quality certifications can be viewed at [www.intersil.com/design/quality](http://www.intersil.com/design/quality)

*Intersil products are sold by description only. Intersil Corporation reserves the right to make changes in circuit design, software and/or specifications at any time without notice. Accordingly, the reader is cautioned to verify that data sheets are current before placing orders. Information furnished by Intersil is believed to be accurate and reliable. However, no responsibility is assumed by Intersil or its subsidiaries for its use; nor for any infringements of patents or other rights of third parties which may result from its use. No license is granted by implication or otherwise under any patent or patent rights of Intersil or its subsidiaries.*

For information regarding Intersil Corporation and its products, see [www.intersil.com](http://www.intersil.com)